



US00D606727S

(12) **United States Design Patent**
Williams

(10) **Patent No.:** **US D606,727 S**
(45) **Date of Patent:** **** Dec. 29, 2009**

(54) **FANNY PACK BELT EXTENDER**

(57) **CLAIM**

(76) **Inventor:** **James Larry Williams**, 2519 Hillside Ct., Sugar Land, TX (US) 77479

The ornamental design for a fanny pack belt extender, as shown and described.

(**) **Term:** **14 Years**

DESCRIPTION

(21) **Appl. No.:** **29/323,435**

FIG. 1 is a front perspective view of a fanny pack belt extender showing my new design;

(22) **Filed:** **Aug. 26, 2008**

FIG. 2 is a rear view of the connector and a portion of the strap prior to assembly;

(51) **LOC (9) Cl.** **02-07**

FIG. 3 is a front view of the connector and a portion of the strap prior to assembly;

(52) **U.S. Cl.** **D2/639**

(58) **Field of Classification Search** D2/625,
D2/626, 624, 627, 629, 639; D29/100, 100.1;
D11/200-201; D3/318, 327; D24/190-191;
297/482; 2/308, 338

FIG. 4 is a rear view of the connector and a portion of the strap prior to assembly;

See application file for complete search history.

FIG. 5 is a front view of the connector and a portion of the strap prior to assembly;

(56) **References Cited**

FIG. 6 is a top view of the connector and a portion of the strap prior to assembly, although the connector is shown in a connected position as in FIG. 1; and,

U.S. PATENT DOCUMENTS

- D243,293 S * 2/1977 Scheimberg D2/625
- 5,052,055 A * 10/1991 Mysliwicz 2/48
- D373,011 S * 8/1996 Rippel D2/627

FIG. 7 is a top view of the connector and a portion of the strap prior to assembly, although the connector is shown in a connected position as in FIG. 1.

* cited by examiner

The broken lines showing of a belt in FIG. 1 and the buckle in FIGS. 2-7 are included for the purpose of showing environmental portions of the fanny pack belt extender and form no part of the claimed design.

Primary Examiner—T. Chase Nelson

Assistant Examiner—Kathleen M Sims

(74) *Attorney, Agent, or Firm*—Browning Bushman P.C.

1 Claim, 2 Drawing Sheets

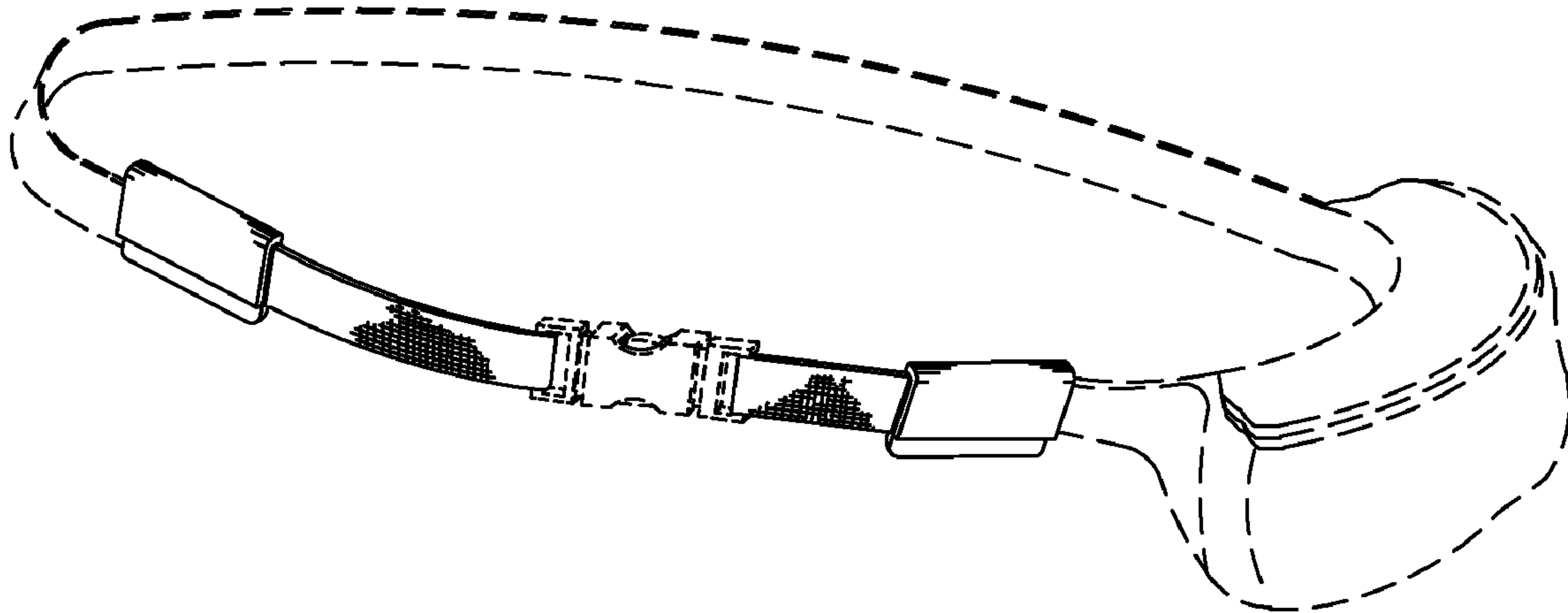

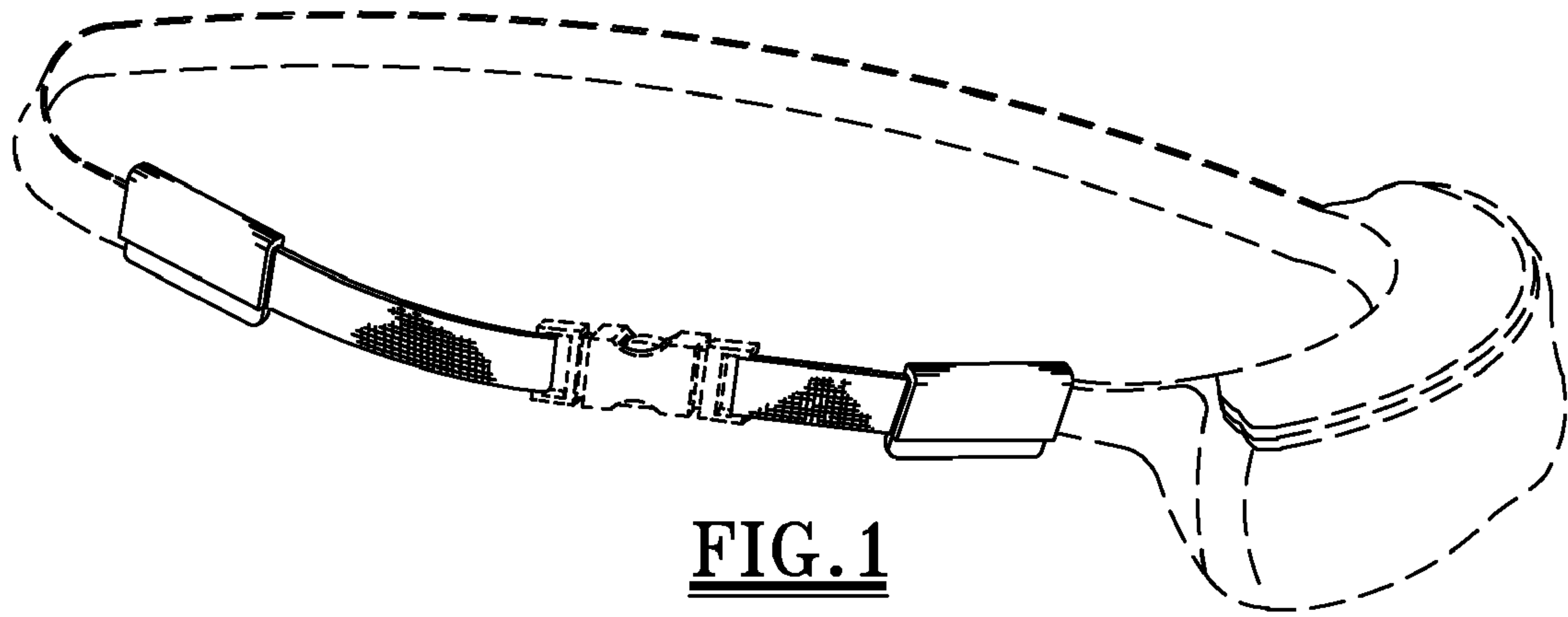

FIG. 1

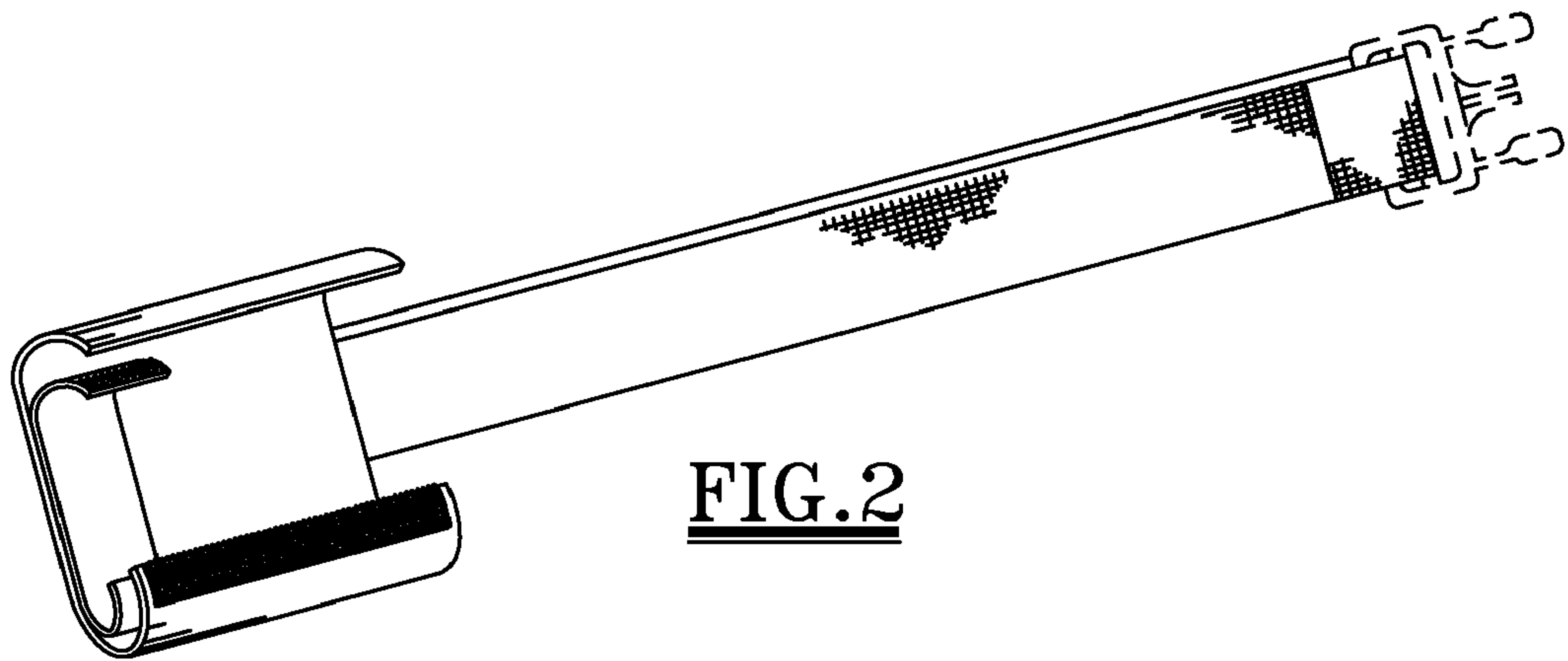

FIG. 2

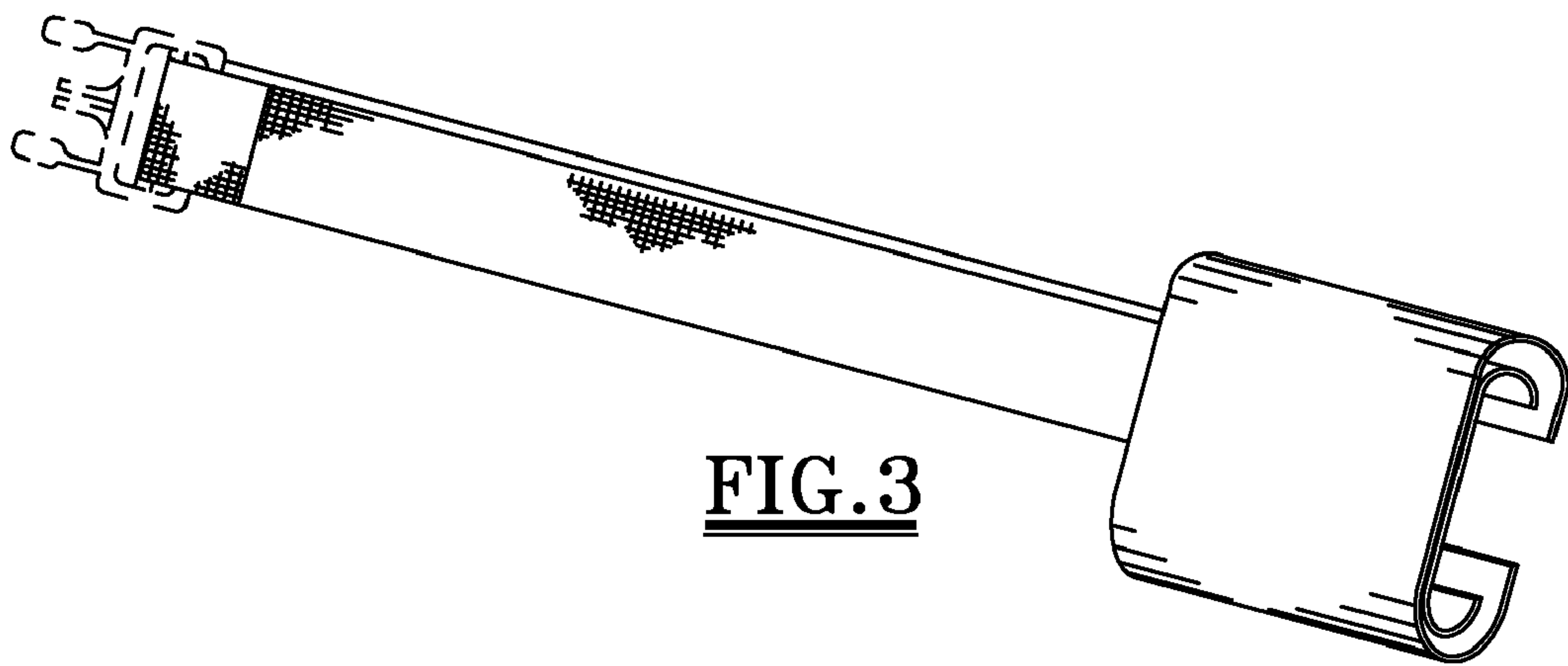

FIG. 3

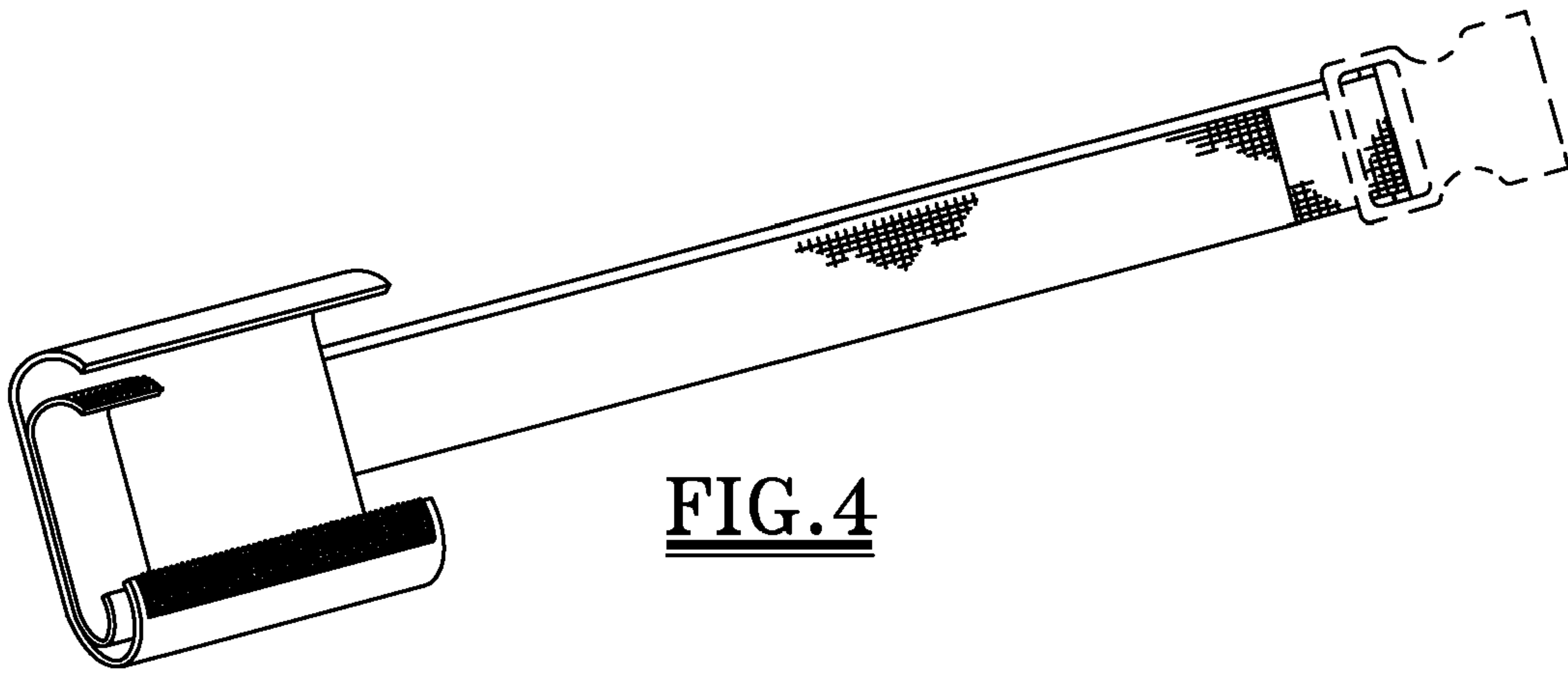

FIG. 4

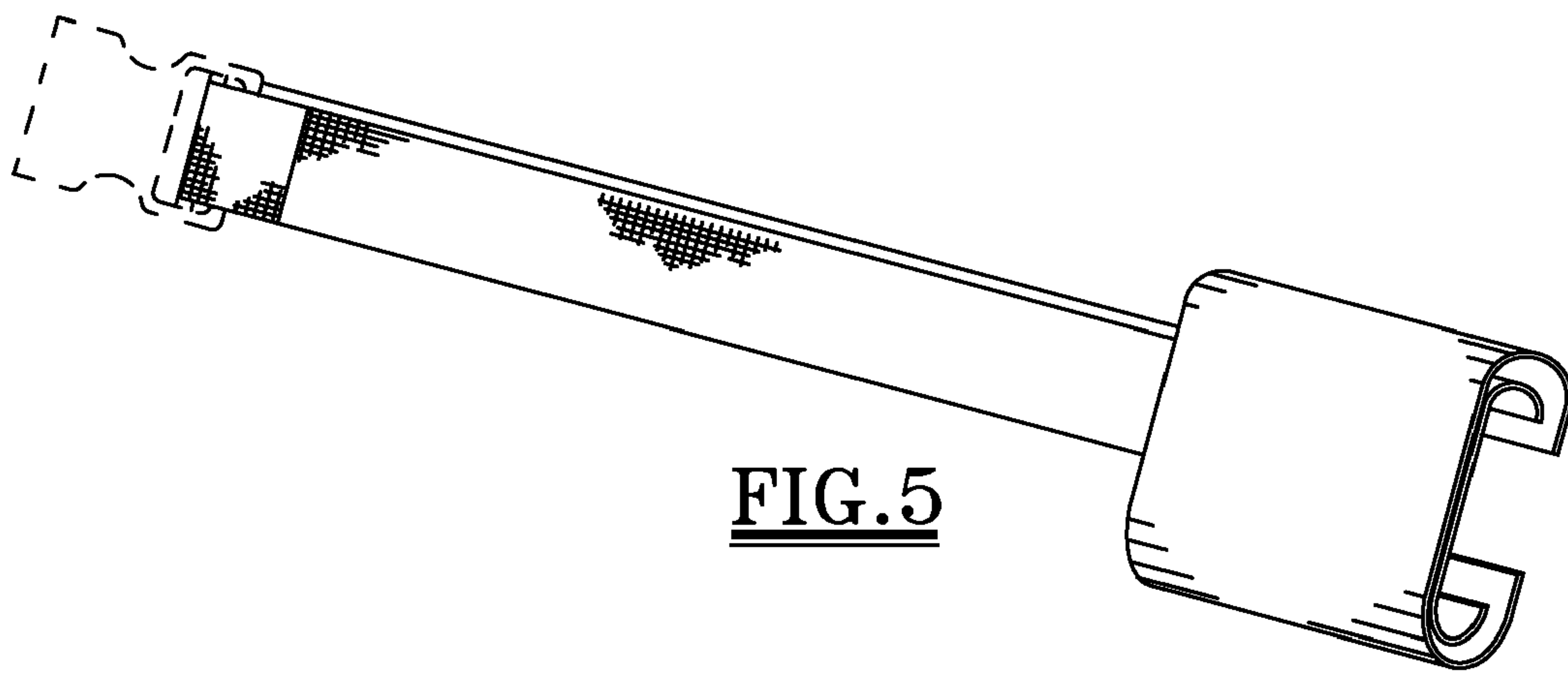

FIG. 5

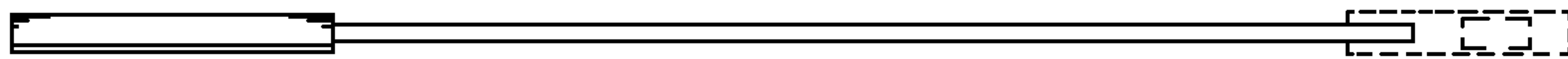

FIG. 6

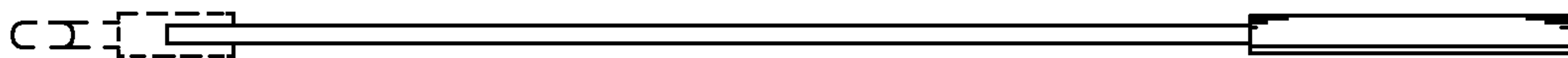

FIG. 7