



US00D606611S

(12) **United States Design Patent**
Rogers et al.

(10) **Patent No.:** **US D606,611 S**

(45) **Date of Patent:** **** Dec. 22, 2009**

(54) **DRIVE SLED**

(75) Inventors: **Orley David Rogers**, Sanford, MI (US);
Zachary Jason Loucks, Mt. Pleasant,
MI (US)

(73) Assignee: **Rogers Athletic Company**, Clare, MI
(US)

(**) Term: **14 Years**

(21) Appl. No.: **29/303,300**

(22) Filed: **Feb. 6, 2008**

(51) **LOC (9) Cl.** **21-02**

(52) **U.S. Cl.** **D21/788**; D21/698

(58) **Field of Classification Search** D21/419-434,
D21/662-697, 698, 760, 767, 769, 770, 771,
D21/777, 788, 801, 802, 803, 814, 828-833;
D6/313, 317, 328, 354, 356, 376, 462, 487,
D6/491, 492, 494, 499, 500-502, 509, 512-574;
D8/349, 354, 367-370, 373, 380; D11/209,
D11/212; D12/6-11, 17, 20, 114, 133, 317,
D12/101, 106, 400, 406, 407, 414, 420, 162,
D12/167, 172, 174, 178, 223; D34/412-27;
D30/134-143, 144, 151; D25/38, 41, 45,
D25/53, 68; 473/415-504; 482/51-78, 83-90,
482/95-134; 280/845-28.18; 297/215.1,
297/215.11, 215.12

See application file for complete search history.

(56) **References Cited**

U.S. PATENT DOCUMENTS

- 2,521,649 A * 9/1950 Paupa 473/445
- 3,780,971 A * 12/1973 De Filippis 248/309.1
- 4,030,750 A * 6/1977 Abram 297/375
- D271,867 S * 12/1983 Danielson D12/119
- D301,653 S * 6/1989 Cacioppo D34/24
- 4,934,938 A * 6/1990 Orlandi et al. 473/444
- 5,284,460 A * 2/1994 Miller et al. 482/51

- D371,529 S * 7/1996 Potter D12/114
- 5,584,780 A * 12/1996 Lin 482/51
- D433,654 S * 11/2000 Gorvine et al. D12/107
- D478,954 S * 8/2003 Forrest D21/788
- 6,634,657 B2 * 10/2003 Graham 280/14.27
- D545,669 S * 7/2007 Hall D8/367
- D562,417 S * 2/2008 Noojin D21/698
- 2008/0312009 A1 * 12/2008 Gilman 473/445

* cited by examiner

Primary Examiner—Catherine Tuttle

(74) *Attorney, Agent, or Firm*—Carlson, Gaskey & Olds

(57) **CLAIM**

We claim the ornamental design for the drive sled, as shown and described.

DESCRIPTION

- FIG. 1 is a top front right oblique view of the drive sled;
- FIG. 2 is a top rear right oblique view of the drive sled;
- FIG. 3 is a bottom front right oblique perspective view of the drive sled;
- FIG. 4 is a bottom rear right oblique perspective view of the drive sled;
- FIG. 5 is a side view of the drive sled;
- FIG. 6 is a top view of the drive sled;
- FIG. 7 is a front view of the drive sled;
- FIG. 8 is a rear view of the drive sled;
- FIG. 9 is a view of the drive sled being used in a pulling exercise; and,
- FIG. 10 is a side view of the drive sled being used in a pushing exercise.

The broken lines are included for the purpose of illustrating portions of the drive sled, users and directional arrows that form no part of the claimed design.

1 Claim, 2 Drawing Sheets

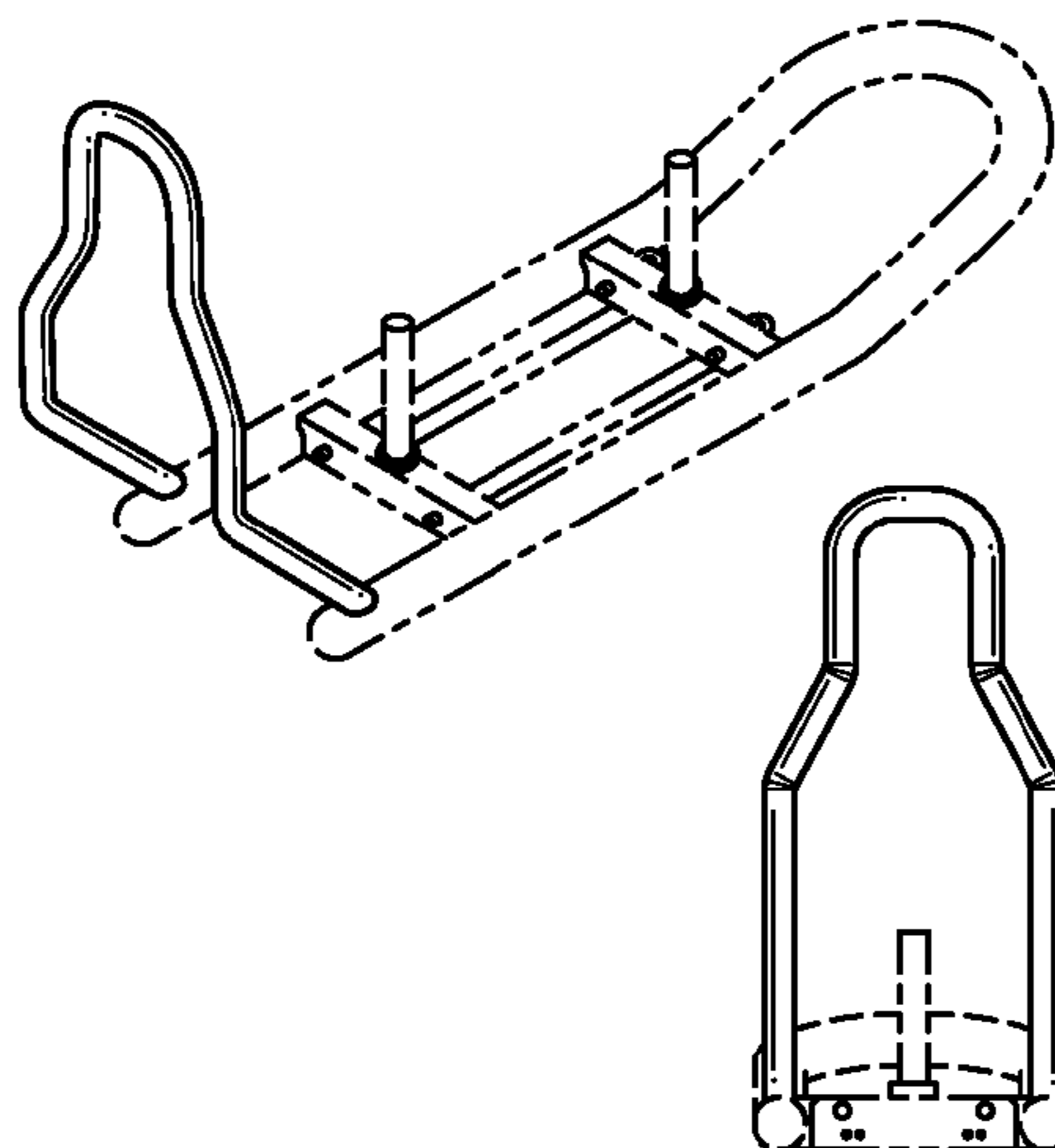

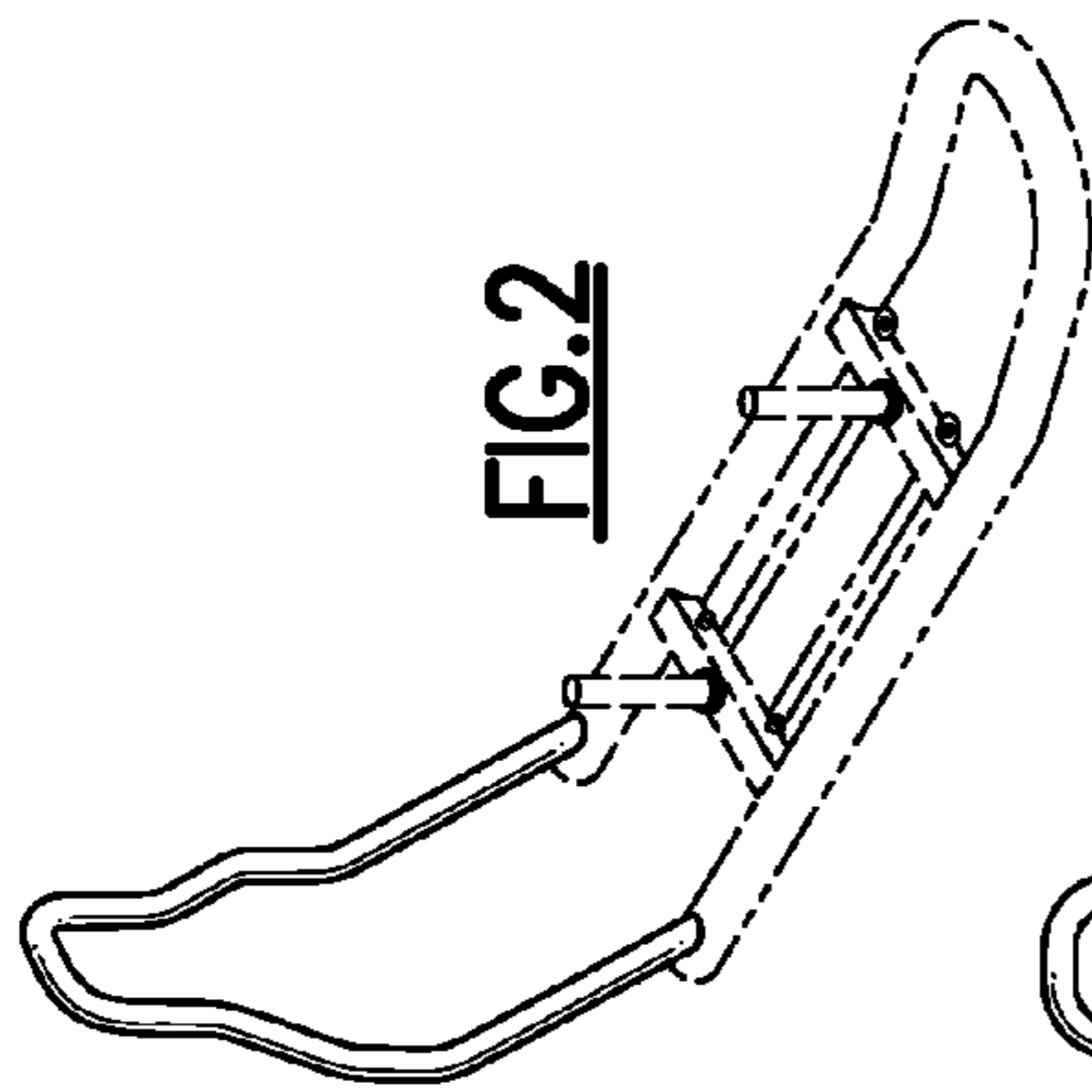

FIG. 2

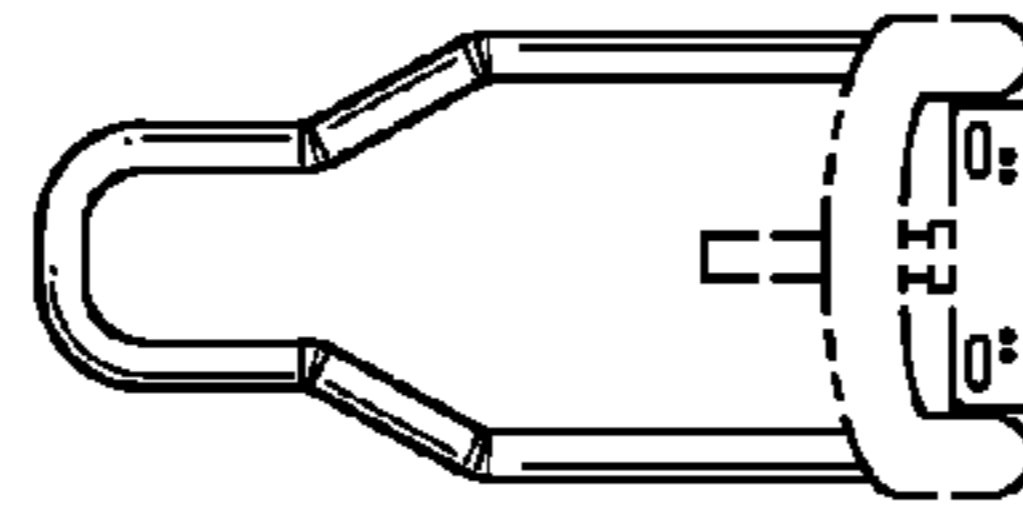

FIG. 8

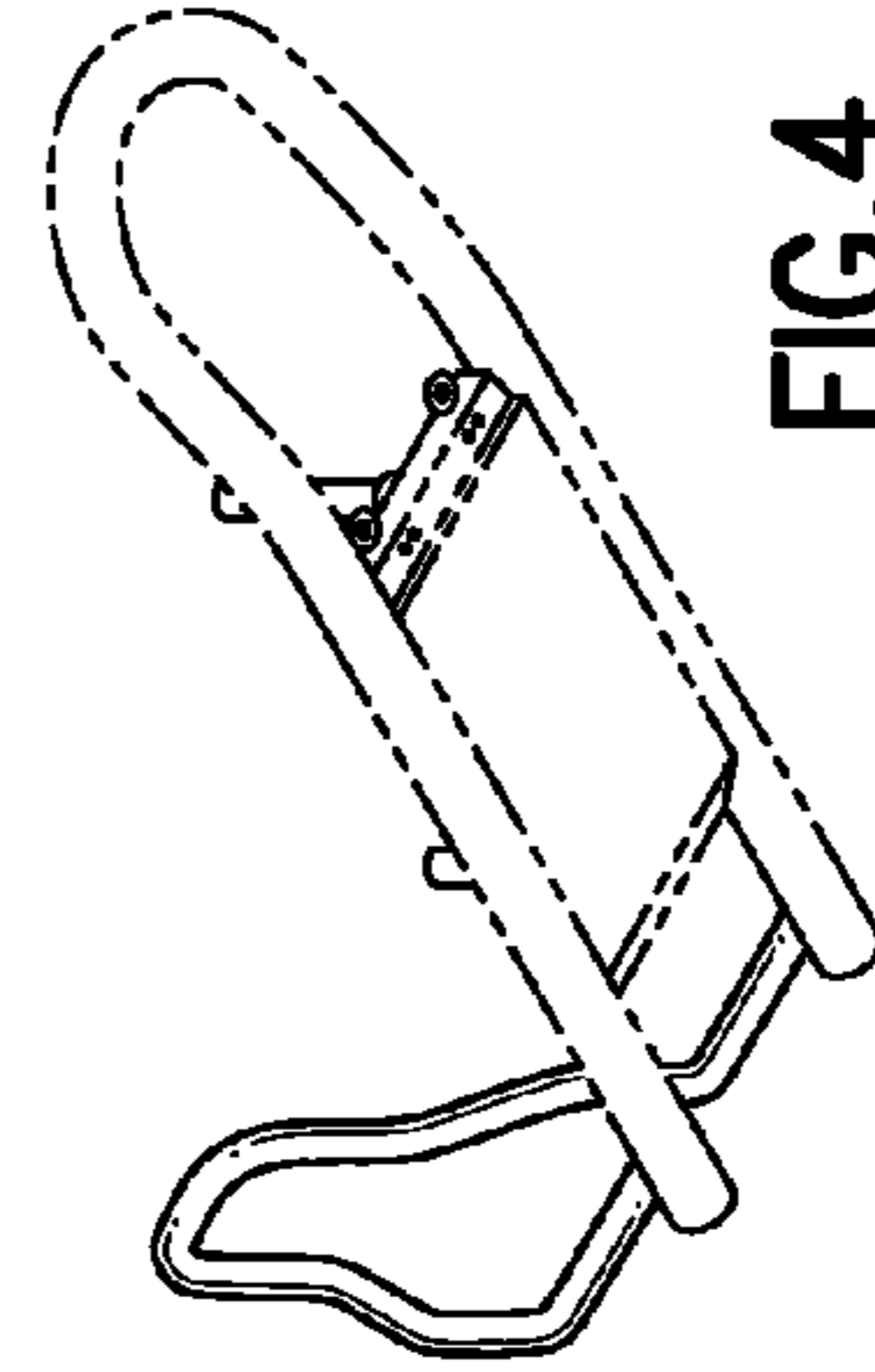

FIG. 4

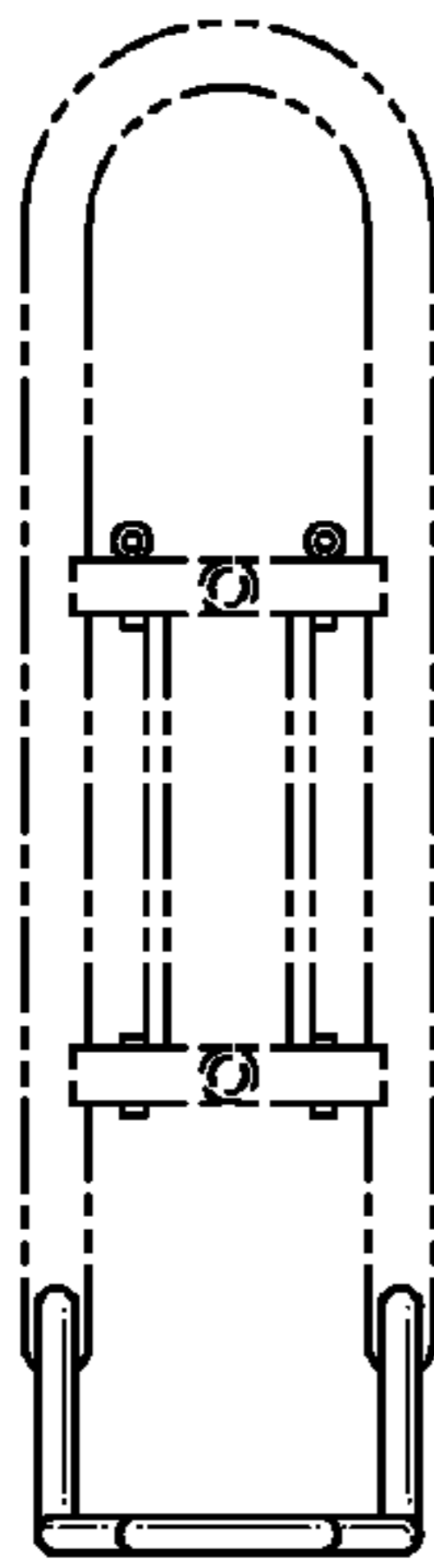

FIG. 6

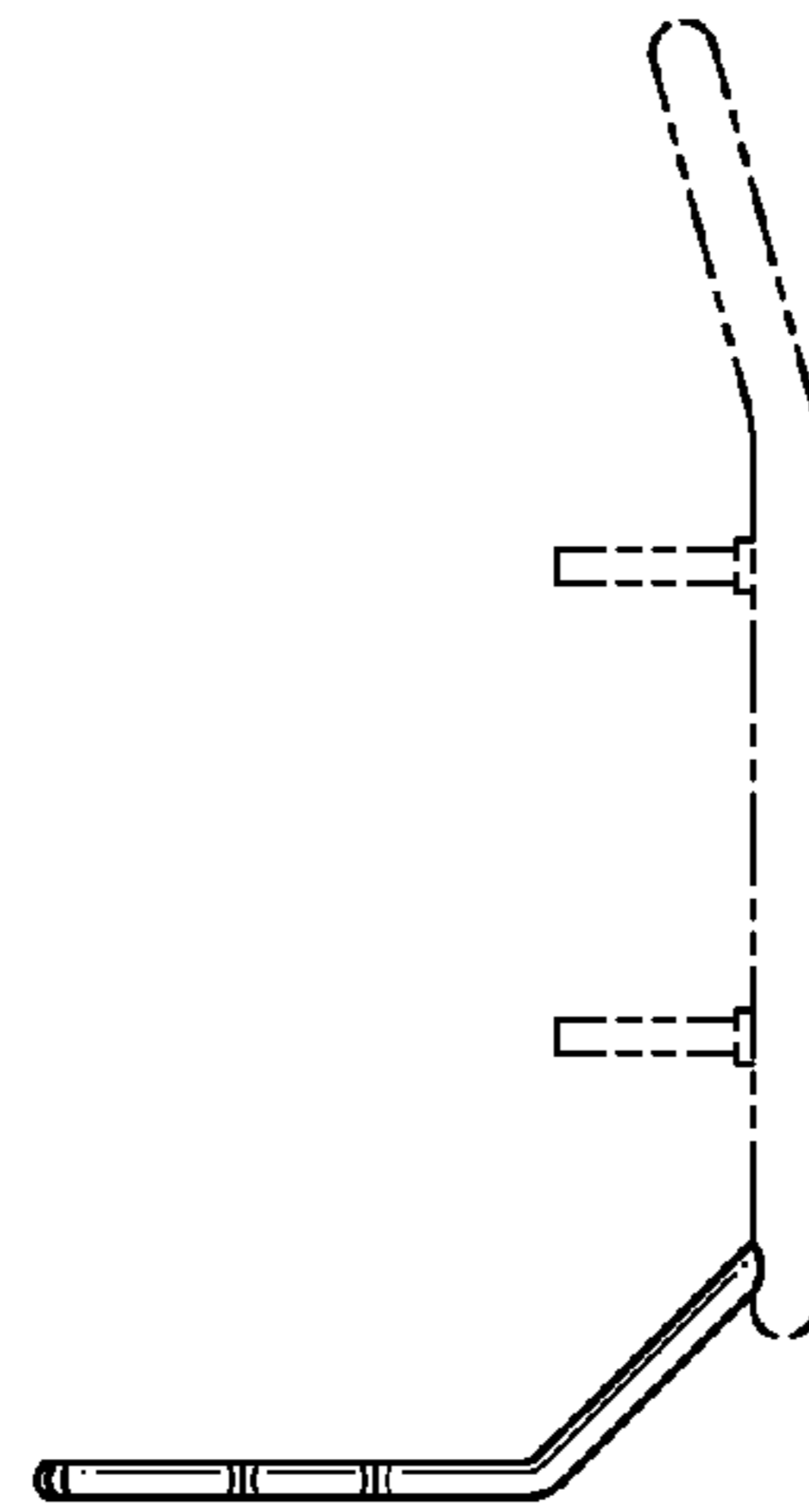

FIG. 5

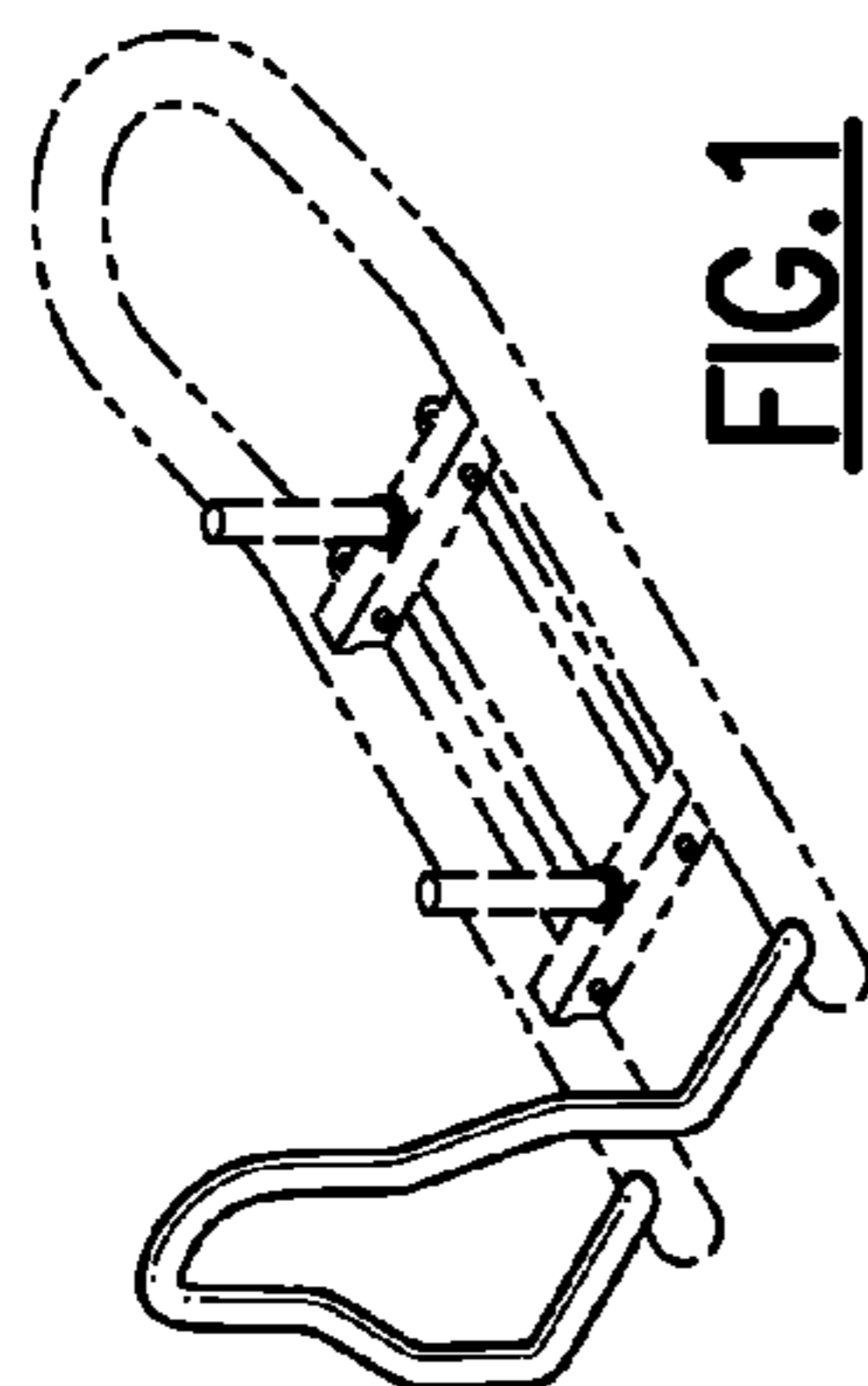

FIG. 1

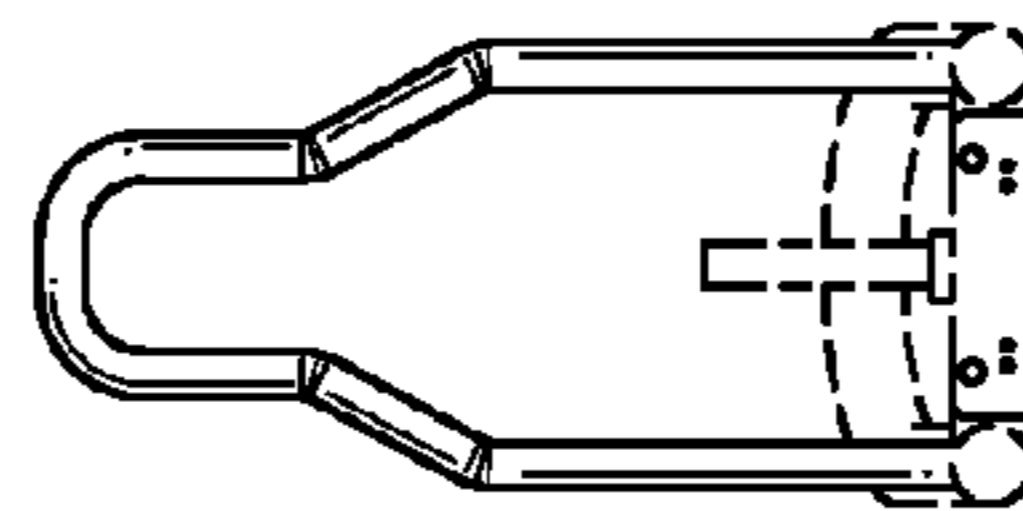

FIG. 7

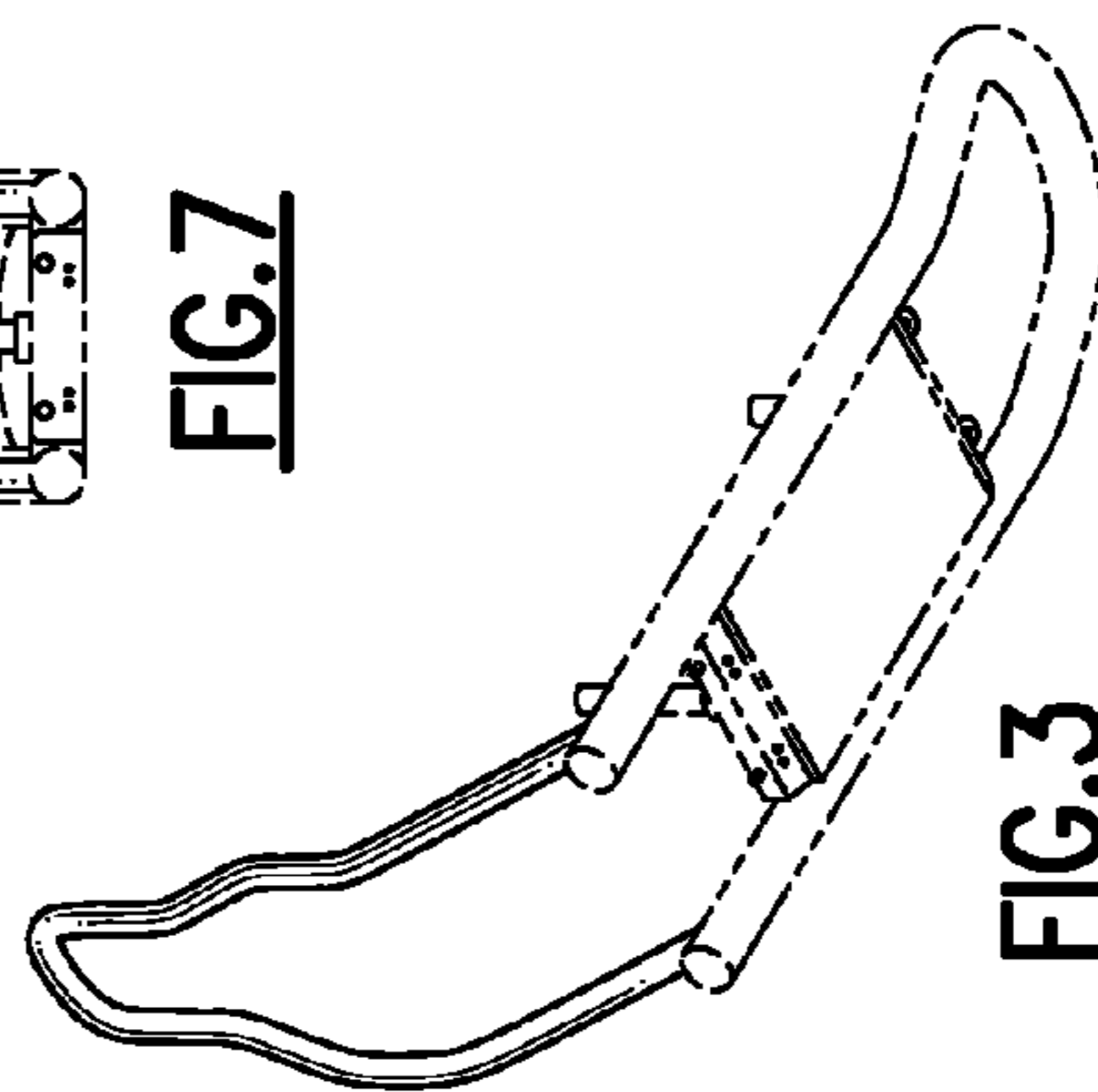

FIG. 3

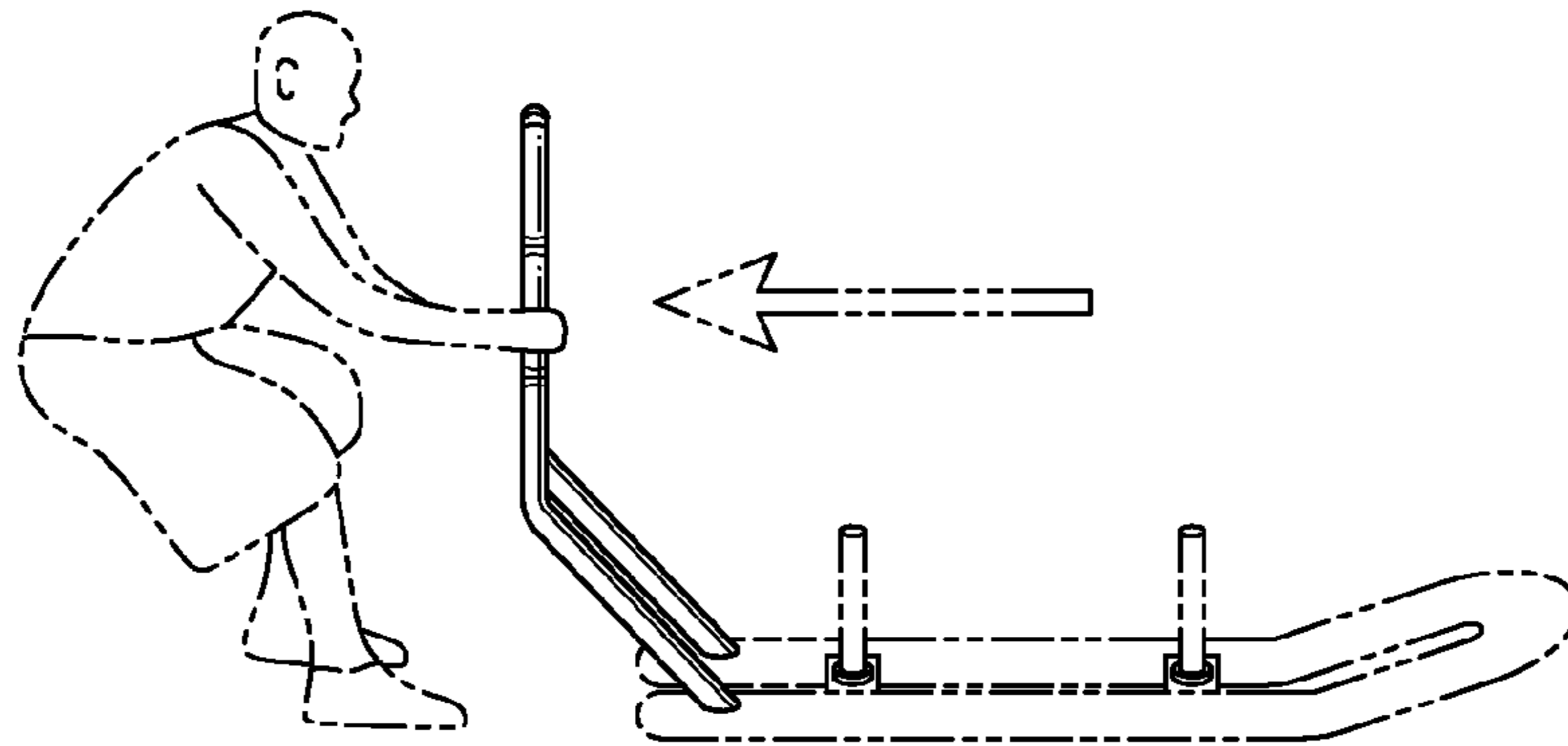

FIG.9

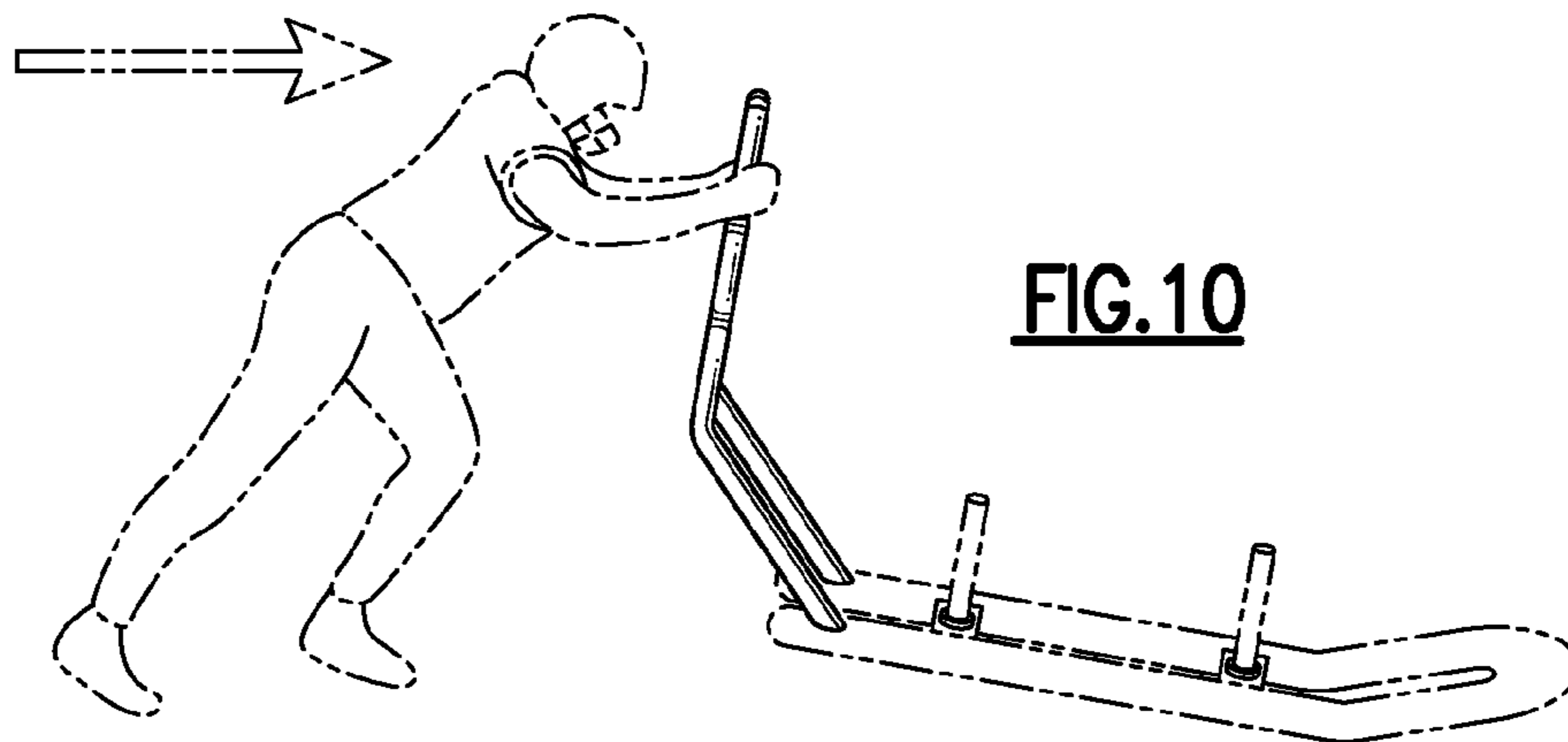

FIG.10