



US00D606481S

(12) **United States Design Patent**
Stepp

(10) **Patent No.:** **US D606,481 S**

(45) **Date of Patent:** **** *Dec. 22, 2009**

(54) **TOP FOR A BOAT**

(75) Inventor: **Steve Stepp**, Lake Mary, FL (US)

(73) Assignee: **Smeecoach Adventures, Inc.**, Carson City, NV (US)

(*) Notice: This patent is subject to a terminal disclaimer.

(**) Term: **14 Years**

(21) Appl. No.: **29/298,576**

(22) Filed: **Dec. 7, 2007**

(51) **LOC (9) Cl.** **12-06**

(52) **U.S. Cl.** **D12/317**

(58) **Field of Classification Search** D12/300-318;
D21/837; D25/56; D3/5; 114/343, 354,
114/361; 135/88.1, 90, 143

See application file for complete search history.

(56) **References Cited**

U.S. PATENT DOCUMENTS

4,926,782	A *	5/1990	Lacy	114/361
D311,169	S *	10/1990	Hoese	D12/318
D315,138	S *	3/1991	Simpkins et al.	D12/304
5,000,210	A *	3/1991	Worthington, Jr.	135/90
5,009,184	A *	4/1991	Voldrich	114/361
D355,883	S *	2/1995	Simpkins	D12/317
D355,885	S *	2/1995	Dells	D12/317
5,520,139	A *	5/1996	King et al.	114/361
D392,243	S *	3/1998	Anderson	D12/317
5,931,114	A *	8/1999	Bartholomew	114/361
6,026,761	A *	2/2000	Parniske et al.	114/343
6,439,150	B1 *	8/2002	Murphy et al.	114/361
6,666,163	B2 *	12/2003	Pastor et al.	114/361
6,799,529	B1 *	10/2004	Willis	114/361

6,983,716	B1 *	1/2006	Ankney et al.	114/361
D524,714	S *	7/2006	Barbeito	D12/300
2002/0053313	A1 *	5/2002	Murphy et al.	114/361
2007/0095272	A1 *	5/2007	Shearer et al.	114/361
2008/0011217	A1 *	1/2008	Russikoff	114/361
2008/0060570	A1 *	3/2008	Bierbower et al.	114/361

* cited by examiner

Primary Examiner—Holly H. Baynham

Assistant Examiner—Cynthia M Chin

(74) *Attorney, Agent, or Firm*—Michael L. Leetzow, P.A.

(57) **CLAIM**

The ornamental design for a top for a boat, as shown and described.

DESCRIPTION

FIG. 1 is a left side perspective view of a top for a boat showing my new design, the top being in an operational configuration;

FIG. 2 is a right side bottom perspective view of the top for a boat shown in FIG. 1;

FIG. 3 is a front view of the top for a boat shown in FIG. 1;

FIG. 4 is a perspective view from the left rear side of the top for a boat shown in FIG. 1;

FIG. 5 is a partial right side top perspective view of the top for a boat shown in FIG. 1 in a transportable position;

FIG. 6 is a front view of the top for a boat shown in FIG. 5; and,

FIG. 7 is a right side view of the top for a boat in FIG. 5.

The broken line illustrations in the drawing figures of the boat are for illustrative purposes only and form no part of the claimed design.

1 Claim, 7 Drawing Sheets

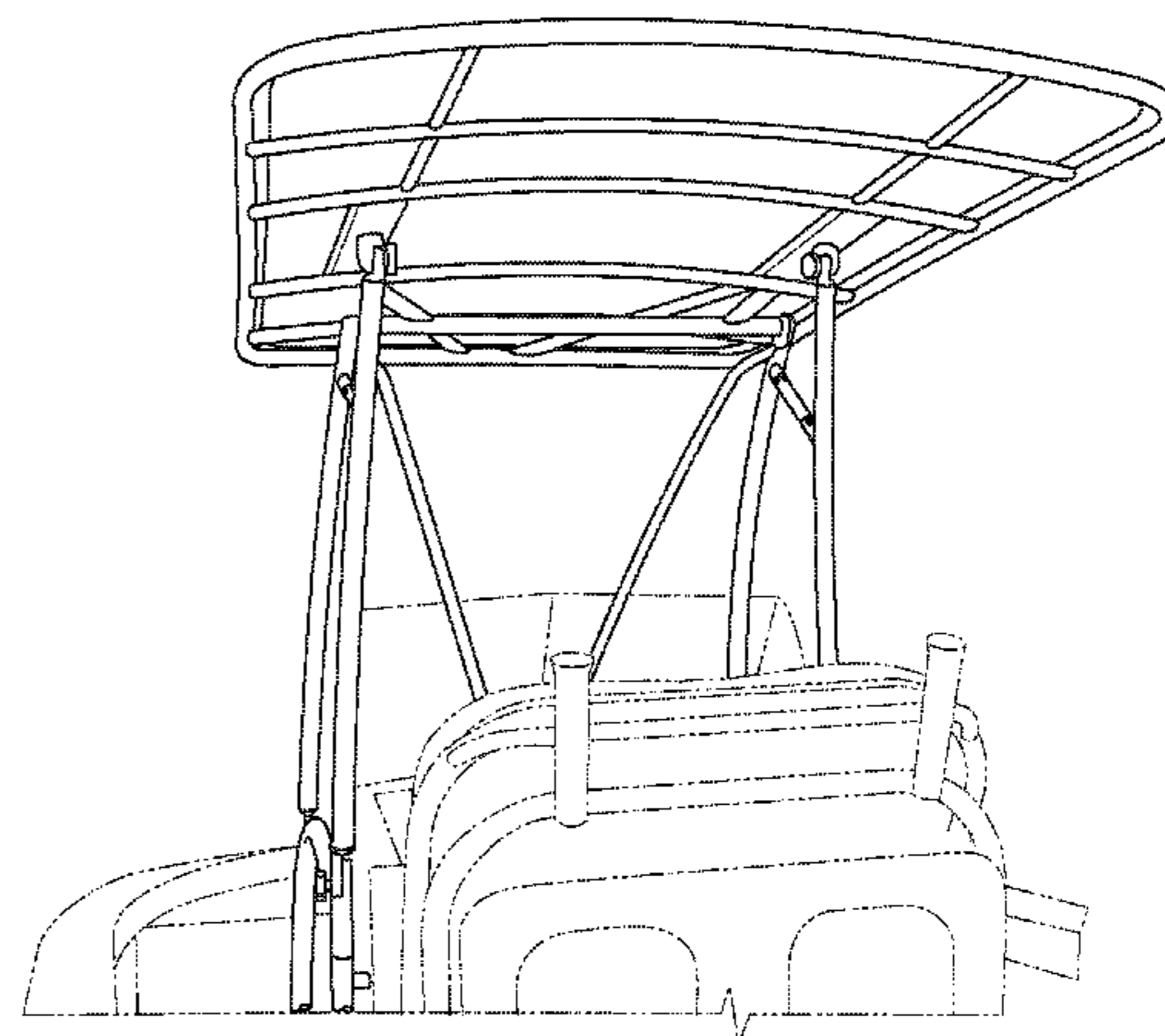
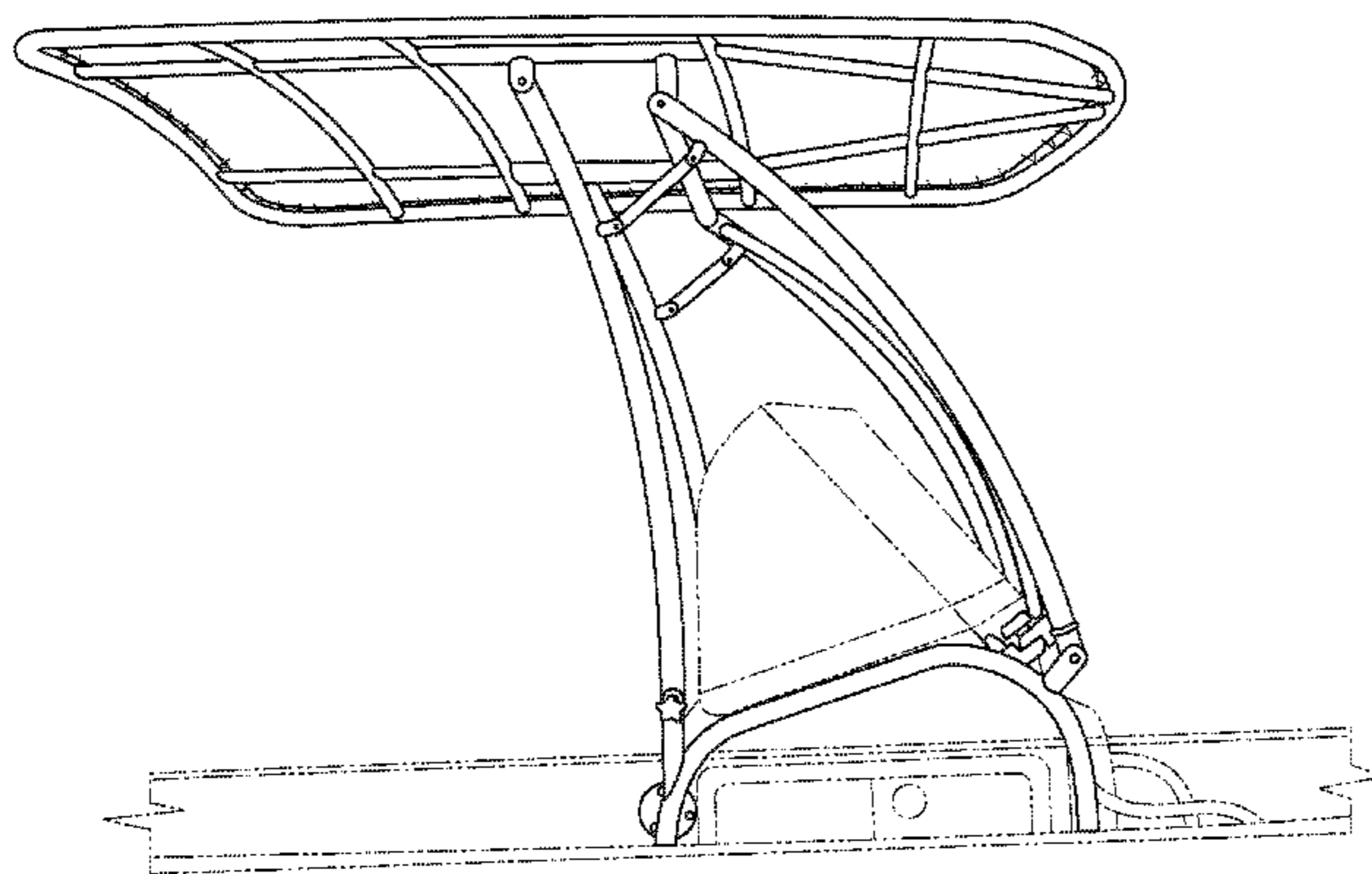

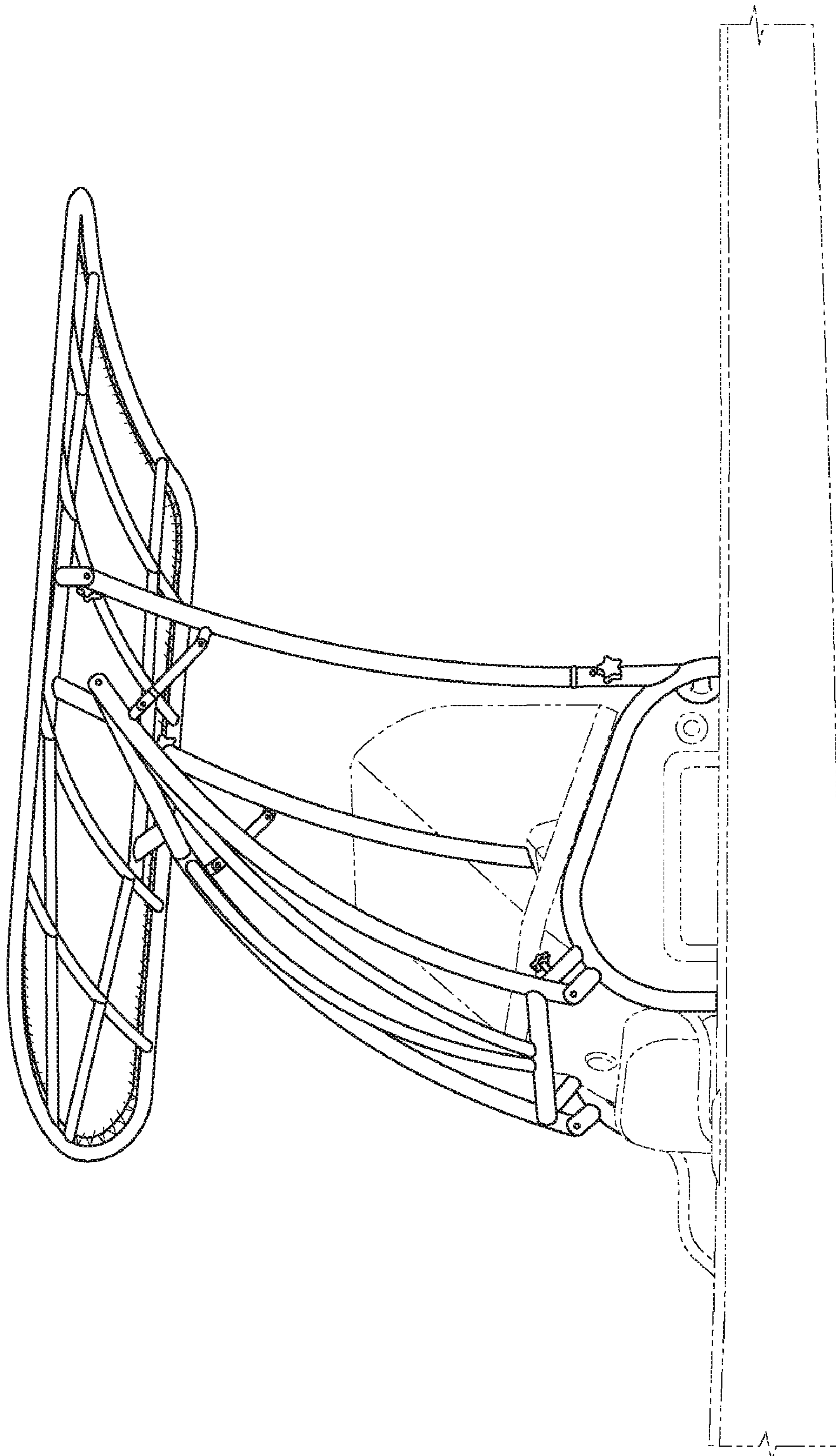

Fig. 1

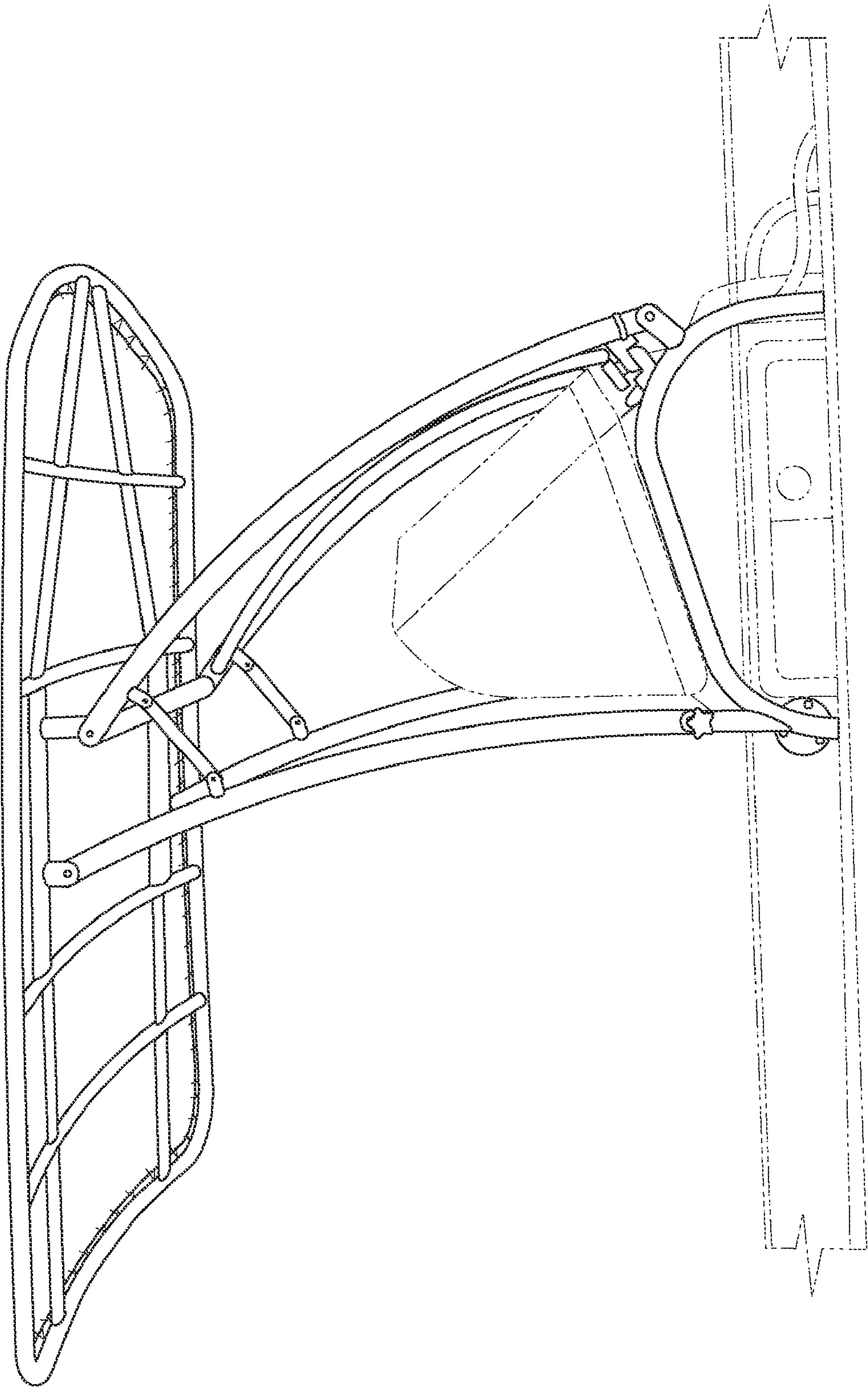

Fig. 2

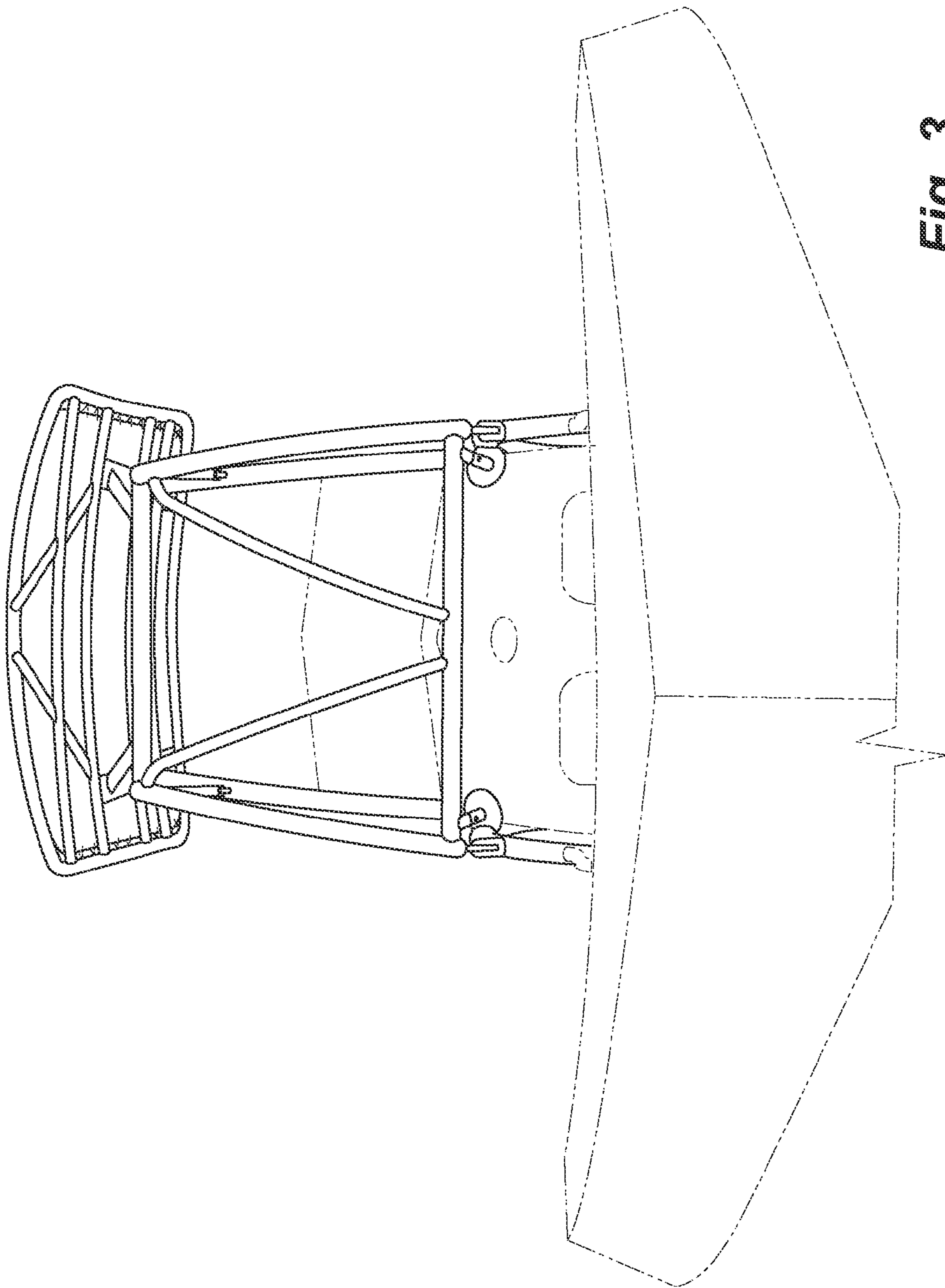

Fig. 3

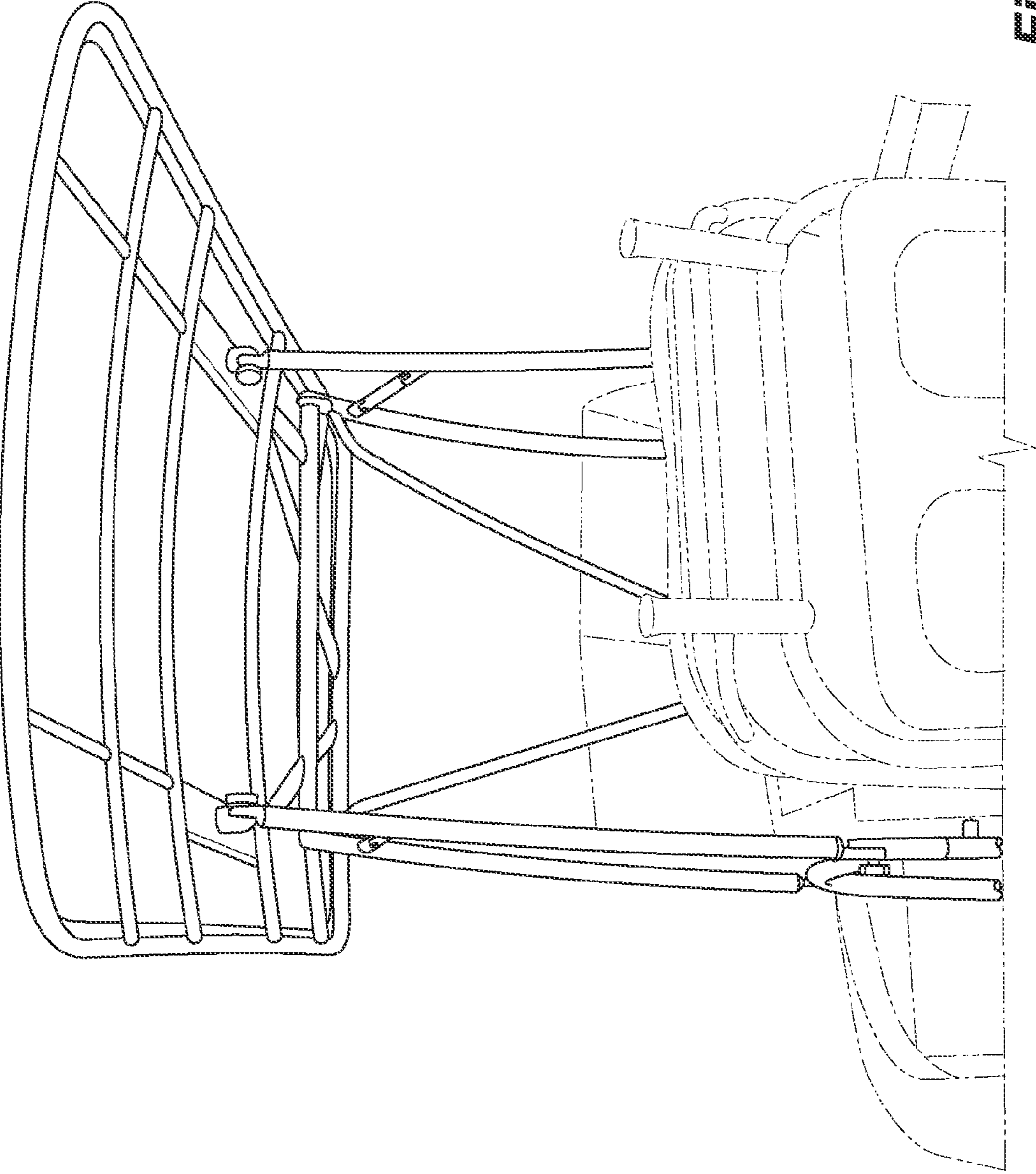

Fig. 4

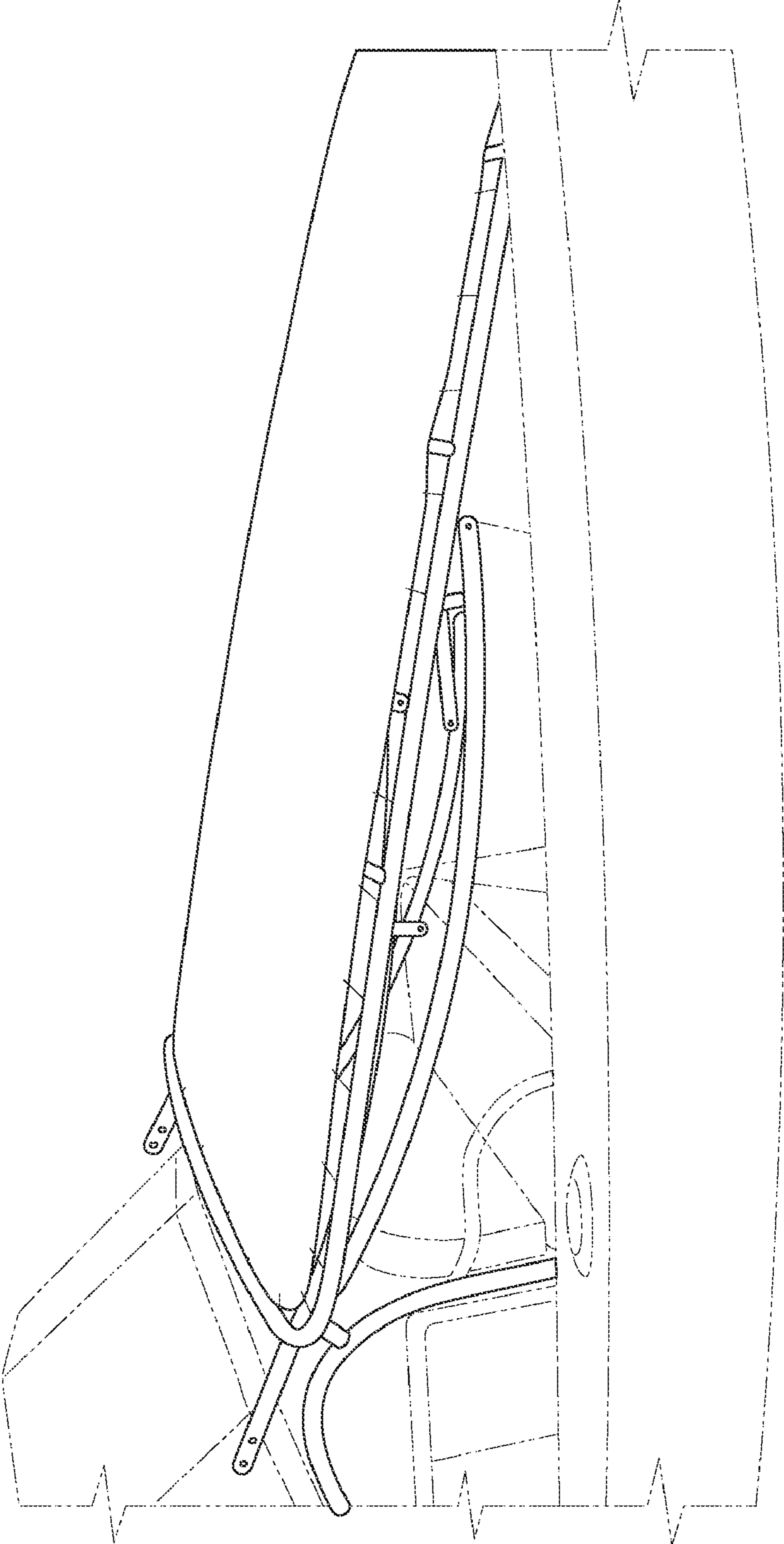

Fig. 5

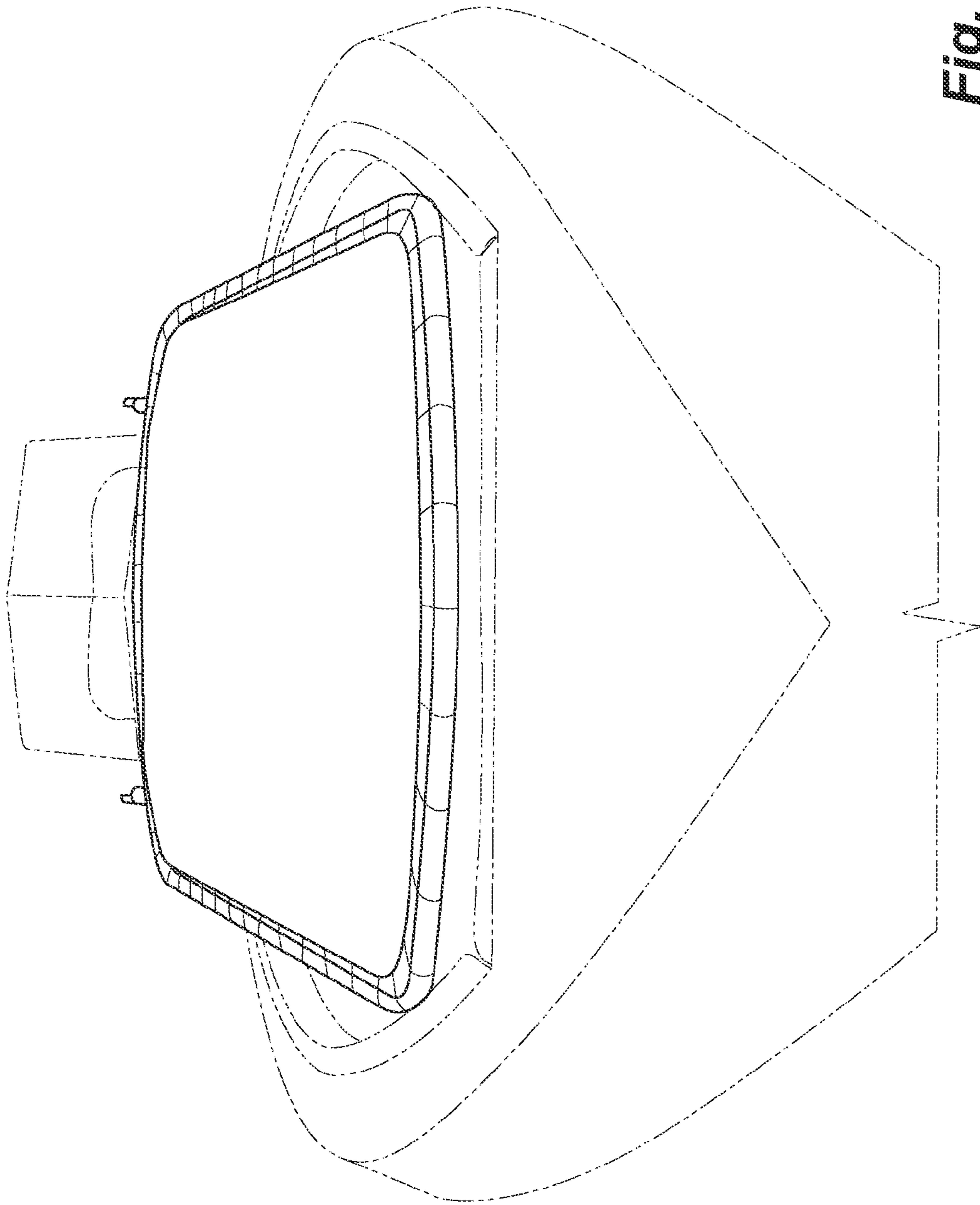

Fig. 6

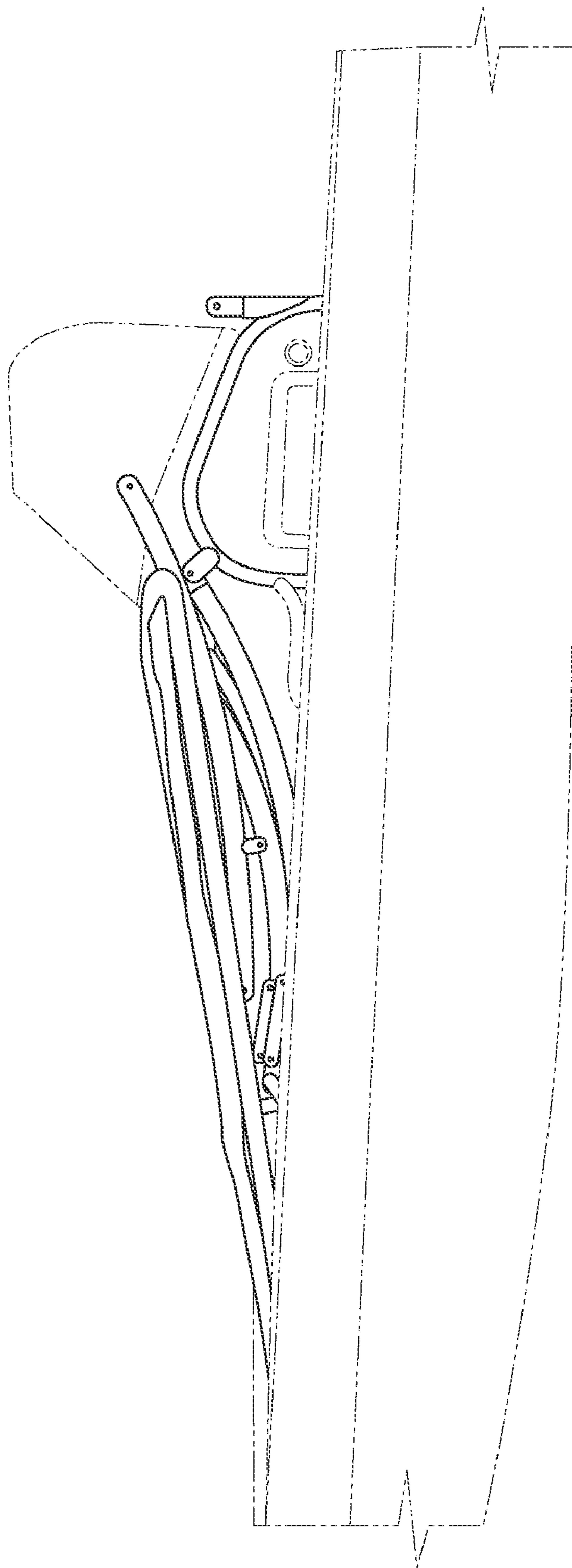

Fig. 7