



US00D605986S

(12) **United States Design Patent**
Raghavendran et al.

(10) **Patent No.:** **US D605,986 S**
(45) **Date of Patent:** **** Dec. 15, 2009**

(54) **VEHICLE GRILLE CROWN**

(75) Inventors: **Kunjithapadam Raghavendran**,
Denton, TX (US); **Dimitri T. Medina**,
Plano, TX (US); **Louis D. Heilaneh**,
Lewisville, TX (US); **Derek Sancer**,
Denton, TX (US); **Peter Smullen**,
Aubrey, TX (US); **David B. Rosen**,
Flower Mound, TX (US)

(73) Assignee: **PACCAR Inc**, Bellevue, WA (US)

(**) Term: **14 Years**

(21) Appl. No.: **29/302,213**

(22) Filed: **Jan. 11, 2008**

(51) **LOC (9) Cl.** **12-16**

(52) **U.S. Cl.** **D12/163**

(58) **Field of Classification Search** D12/93,
D12/96, 97, 163, 173; 180/68.1, 68.6, 69.1,
180/89.1, 89.12; 296/190, 193.1, 194
See application file for complete search history.

(56) **References Cited**

U.S. PATENT DOCUMENTS

D307,731 S	5/1990	Kerney	
D308,032 S	5/1990	Kerney	
D312,805 S	12/1990	Marlowe	
D313,784 S *	1/1991	Marlow et al.	D12/163
D389,108 S	1/1998	Norwood	
D412,874 S	8/1999	Meryman	
D425,835 S	5/2000	Cook	
D447,099 S *	8/2001	Tirey et al.	D12/163
D484,077 S	12/2003	Conway	
D497,581 S	10/2004	Conway	
D502,897 S *	3/2005	Delashaw et al.	D12/163
D504,850 S	5/2005	Gunter	
D551,133 S *	9/2007	Angelo et al.	D12/163

OTHER PUBLICATIONS

Kenworth Truck Company, Kirkland, Washington, "T600A," 1985,
10-page brochure.

Kenworth Truck Company, Kirkland, Washington, "AeroCab," 1993,
6-page brochure.

Kenworth Truck Company, Kirkland, Washington, "Studio Sleeper,"
1993, 5-page brochure.

Kenworth Truck Company, Kirkland, Washington, "W900L
AeroCab," 1994, 2-page brochure.

Kenworth Truck Company, Kirkland, Washington, "T600," 1996,
7-page brochure.

Kenworth Truck Company, Kirkland, Washington, "T800," 1996,
7-page brochure.

Kenworth Truck Company, Kirkland, Washington, "W900," 1996,
7-page brochure.

Kenworth Truck Company, Kirkland, Washington, "T300," 1997,
5-page brochure.

(Continued)

Primary Examiner—Robert M Spear

Assistant Examiner—Barbara B Lohr

(74) *Attorney, Agent, or Firm*—Christensen O'Connor
Johnson Kindness PLLC

(57) **CLAIM**

The ornamental design for a vehicle grille crown, as shown
and described.

DESCRIPTION

FIG. 1 is a front perspective view of a vehicle grille crown
showing our new design;

FIG. 2 is a front elevational view thereof;

FIG. 3 is a left side view thereof, the right side view being
mirror symmetrical to FIG. 3; and,

FIG. 4 is a top plan view thereof.

The broken line showing of the vehicle grille, in FIGS. 1-4,
depicts environment and forms no part of the claimed design.

The rear and the bottom of the vehicle grille crown is unornamented.

1 Claim, 2 Drawing Sheets

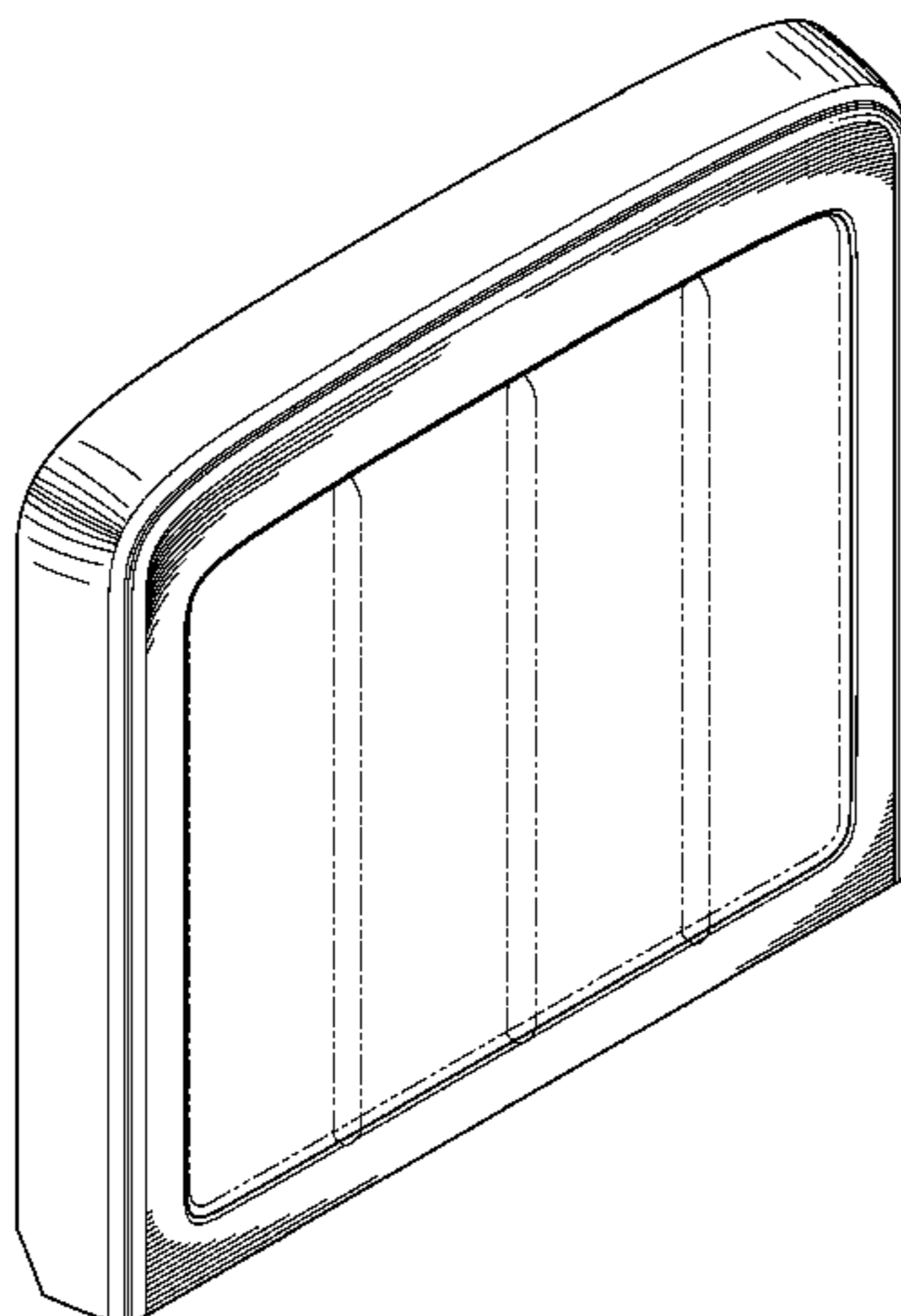

OTHER PUBLICATIONS

- Kenworth Truck Company, Kirkland, Washington, "T2000," 1999, 20-page brochure.
- Peterbilt Motors Company, Denton, Texas, "Model 357," May 1994, 3-page brochure.
- Peterbilt Motors Company, Denton, Texas, "Unibilt™ Cab Sleeper System," Aug. 1994, 6-page brochure.
- Peterbilt Motors Company, Denton, Texas, "Model 377A/E," Jan. 1995, 6-page brochure.
- Peterbilt Motors Company, Denton, Texas, "Model 379," Mar. 1996, 5-page brochure.
- Peterbilt Motors Company, Denton, Texas, "Model 320," May 1996, 2-page brochure.
- Peterbilt Motors Company, Denton, Texas, "Model 385," Oct. 1996, 5-page brochure.
- Peterbilt Motors Company, Denton, Texas, "Model 377A/E," Aug. 1997, 2-page brochure.
- Peterbilt Motors Company, Denton, Texas, "Class Pays," Sep. 1997, 10-page brochure.
- Peterbilt Motors Company, Denton, Texas, "Model 330," Oct. 1997, 3-page brochure.
- Peterbilt Motors Company, Denton, Texas, "Model 378," Mar. 1998, 3-page brochure.
- Peterbilt Motors Company, Denton, Texas, "Class Pays," Nov. 1998, 10-page brochure.
- Peterbilt Motors Company, Denton, Texas, "Class Pays, Ergonomic Dash," Mar. 2000, 2-page brochure.
- Peterbilt Motors Company, Denton, Texas, "Class Pays, Medium Duty," Sep. 2000, 12-page brochure.
- Peterbilt Motors Company, Denton, Texas, "Model 357, New Sloped Hood," May 2002, 2-page brochure.
- Peterbilt Motors Company, Denton, Texas, "Model 387," Oct. 2002, 2-page brochure.
- Peterbilt Motors Company, Denton, Texas, "Class Pays Refuse Trucks," Sep. 2003, 2-page brochure.
- Peterbilt Motors Company, Denton, Texas, "Model 357 Heavy Haul," Mar. 2005, 2-page brochure.
- Peterbilt Motors Company, Denton, Texas, "Model 357-¹¹⁵," Mar. 2005, 2-page brochure.
- Peterbilt Motors Company, Denton, Texas, "Model 379," Apr. 2005, 2-page brochure.
- Peterbilt Motors Company, Denton, Texas, "Class Pays, Platinum Interior," May 2005, 4-page brochure.
- Peterbilt Motors Company, Newark, California, "The Working Class," Sep. 1976, 6-page brochure.
- Peterbilt Motors Company, Newark, California, "Rest with Class," Apr. 1978, 4-page brochure.
- Peterbilt Motors Company, Newark, California, "Model 362," 1985, 8-page brochure.
- Peterbilt Motors Company, Newark, California, "Model 357 Standard Specifications," Sep. 1986, 6-page brochure.
- Peterbilt Motors Company, Newark, California, "Model 375 Standard Specifications," Sep. 1986, 6-page brochure.
- Peterbilt Motors Company, Denton, Texas, "Peterbilt Parts & Accessories" catalog, as early as 2000.

* cited by examiner

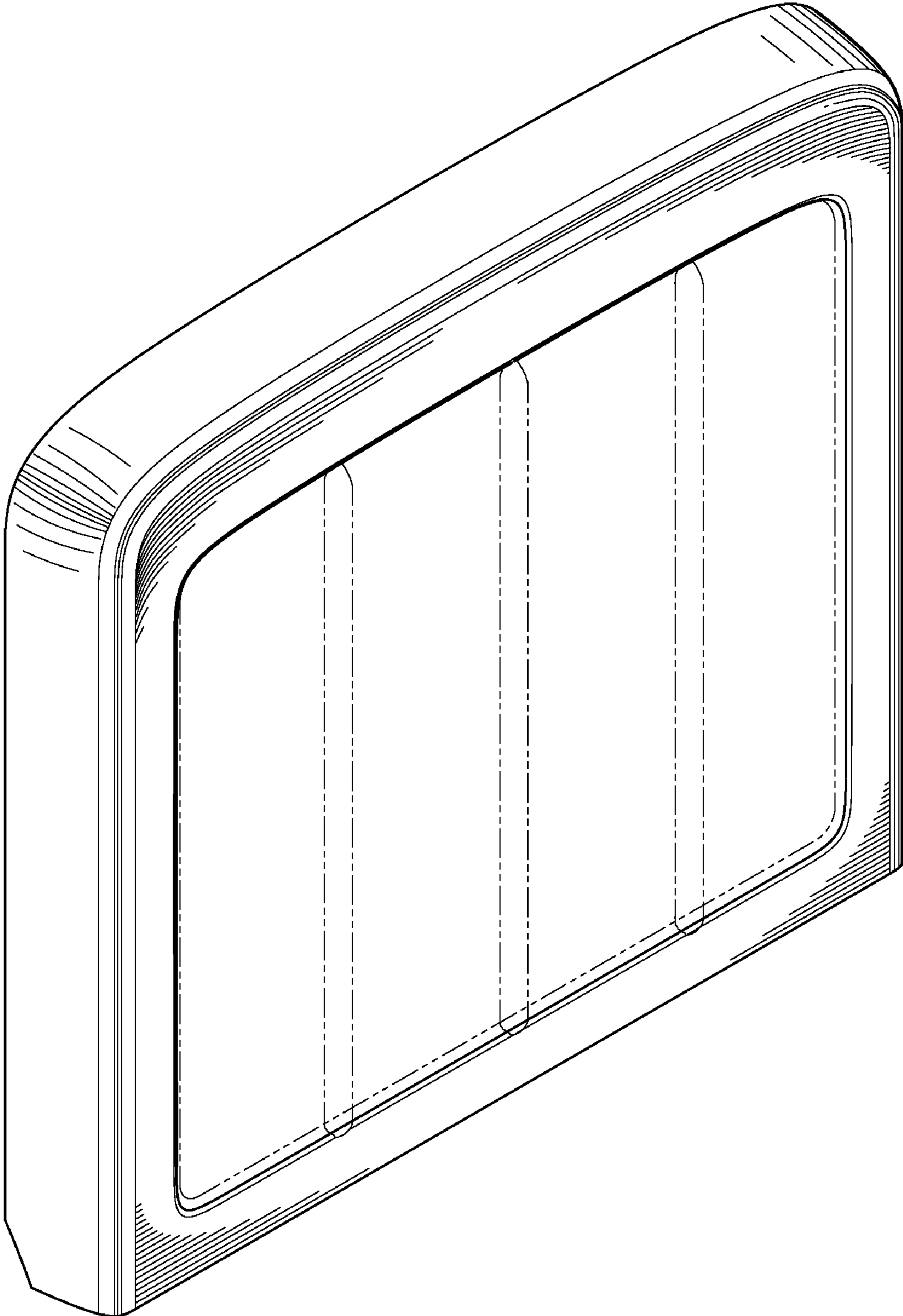

Fig. 1.

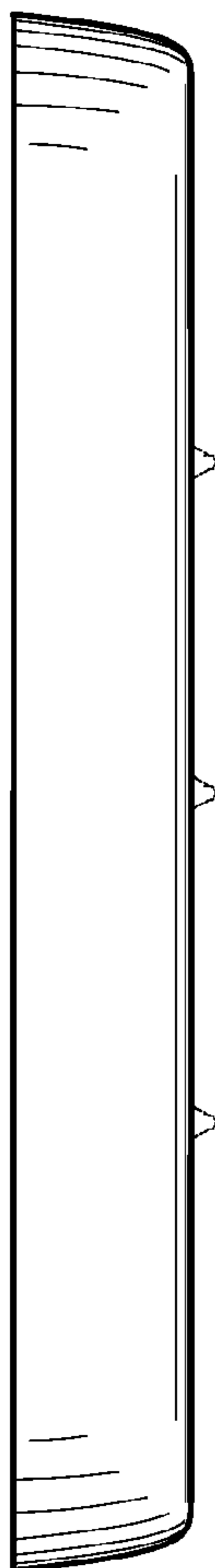

Fig. 4.

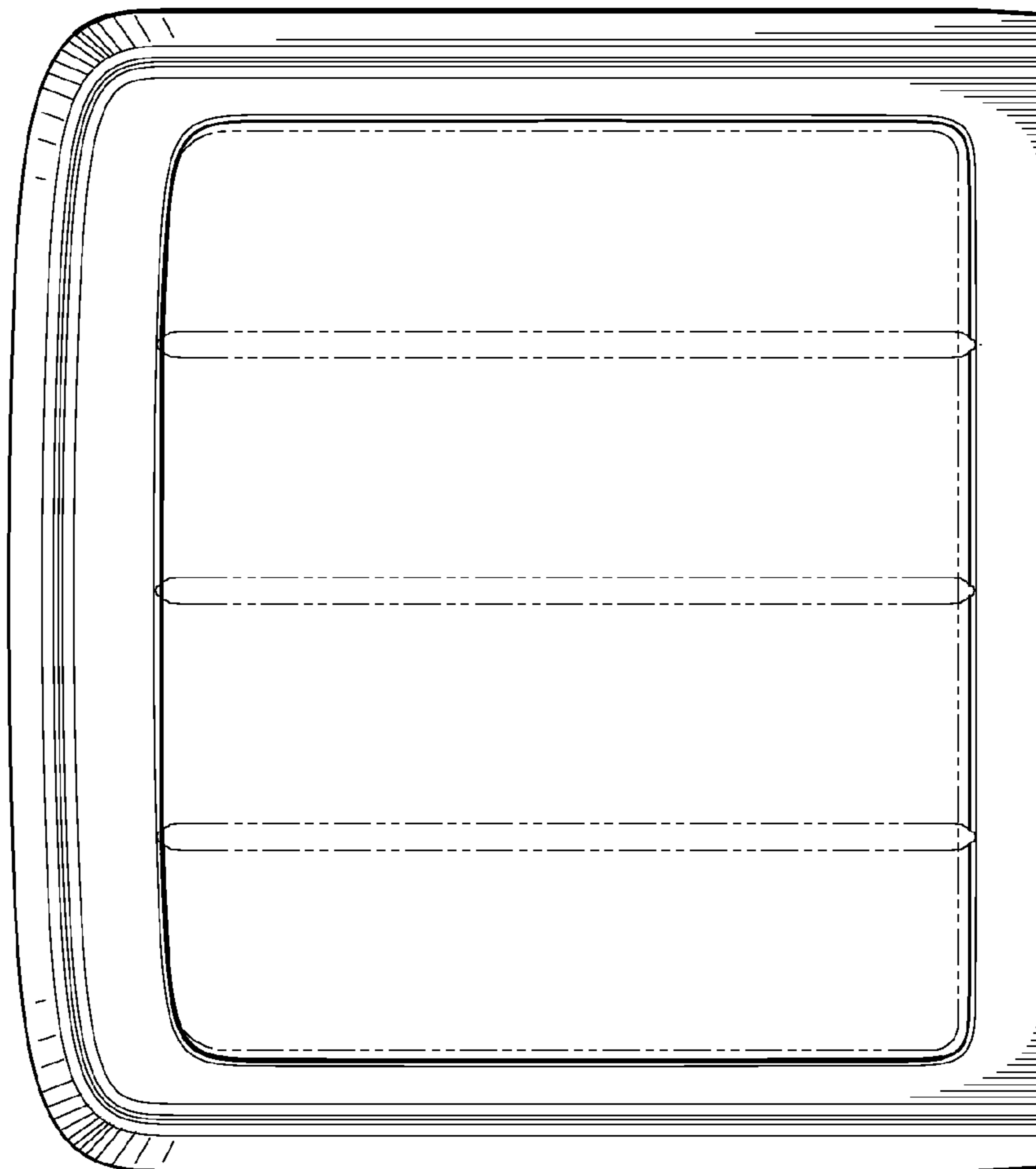

Fig. 2.

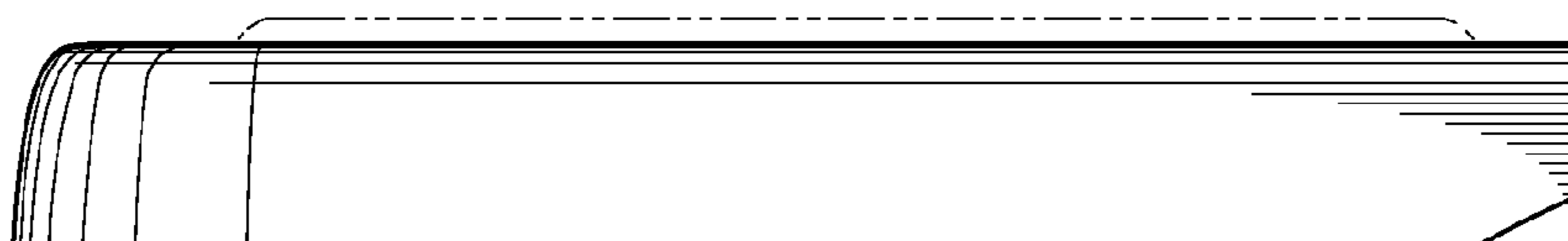

Fig. 3.