



US00D605982S

(12) **United States Design Patent**
Tanaka et al.

(10) **Patent No.:** **US D605,982 S**
(45) **Date of Patent:** **** Dec. 15, 2009**

(54) **MOTORCYCLE**

(75) Inventors: **Shunji Tanaka**, Kobe (JP); **Tsutomu Shimizugami**, Kakogawa (JP); **Toshiya Furuta**, Kobe (JP)

(73) Assignee: **Kawasaki Jukogyo Kabushiki Kaisha**, Hyogo (JP)

(**) Term: **14 Years**

(21) Appl. No.: **29/333,855**

(22) Filed: **Mar. 16, 2009**

(30) **Foreign Application Priority Data**

Sep. 16, 2008 (JP) 2008-023564

(51) **LOC (9) Cl.** **12-11**

(52) **U.S. Cl.** **D12/110**

(58) **Field of Classification Search** D12/110;
180/219, 220

See application file for complete search history.

(56) **References Cited**

U.S. PATENT DOCUMENTS

D286,519 S	*	11/1986	Komuro et al.	D12/110
D296,539 S	*	7/1988	Yamada et al.	D12/110
D384,916 S	*	10/1997	Rodriguez Ferre	D12/110
D426,174 S	*	6/2000	Sofue et al.	D12/110
D444,419 S	*	7/2001	Kamata et al.	D12/110

OTHER PUBLICATIONS

2007 Harley-Davidson® 2007 FLHTCUSE 2 Screamin' Eagle® Ultra Classic® Electra Glide®, on brochure cover.*

2007 Harley-Davidson® FLHTCU Ultra Classic® Electra Glide® Patriot Edition, first available for purchase from Aug. 14, 2006-Jan. 15, 2007, on brochure cover.*

1994 Harley-Davidson® Electra Glide® Ultra Classic®. [Retrieved on Aug. 4, 2009]. Retrieved from the Internet <URL: http://www.santamonica-harley.com/ELECTRA_GLIDE_ULTRA_CLASSIC_1994/1.jpg>.*
Japanese Magazine "Motorcycle" published Aug. 1, 2008, No. 12, the excerpt of which is on the Notification of Reasons for Rejection, p. 96 of the magazine, 6 pages.

* cited by examiner

Primary Examiner—Cathron C Brooks

Assistant Examiner—Linda G. Brooks

(57) **CLAIM**

The ornamental design for a motorcycle, as shown and described.

DESCRIPTION

FIG. 1 is a front elevational view of a motorcycle showing our new design;

FIG. 2 is a rear elevational view thereof;

FIG. 3 is a left side elevational view thereof;

FIG. 4 is a right side elevational view thereof;

FIG. 5 is a top plan view thereof;

FIG. 6 is a bottom plan view thereof;

FIG. 7 is a front left perspective view thereof;

FIG. 8 is a front right perspective view thereof;

FIG. 9 is a rear left perspective view thereof; and,

FIG. 10 is a rear right perspective view thereof.

1 Claim, 10 Drawing Sheets

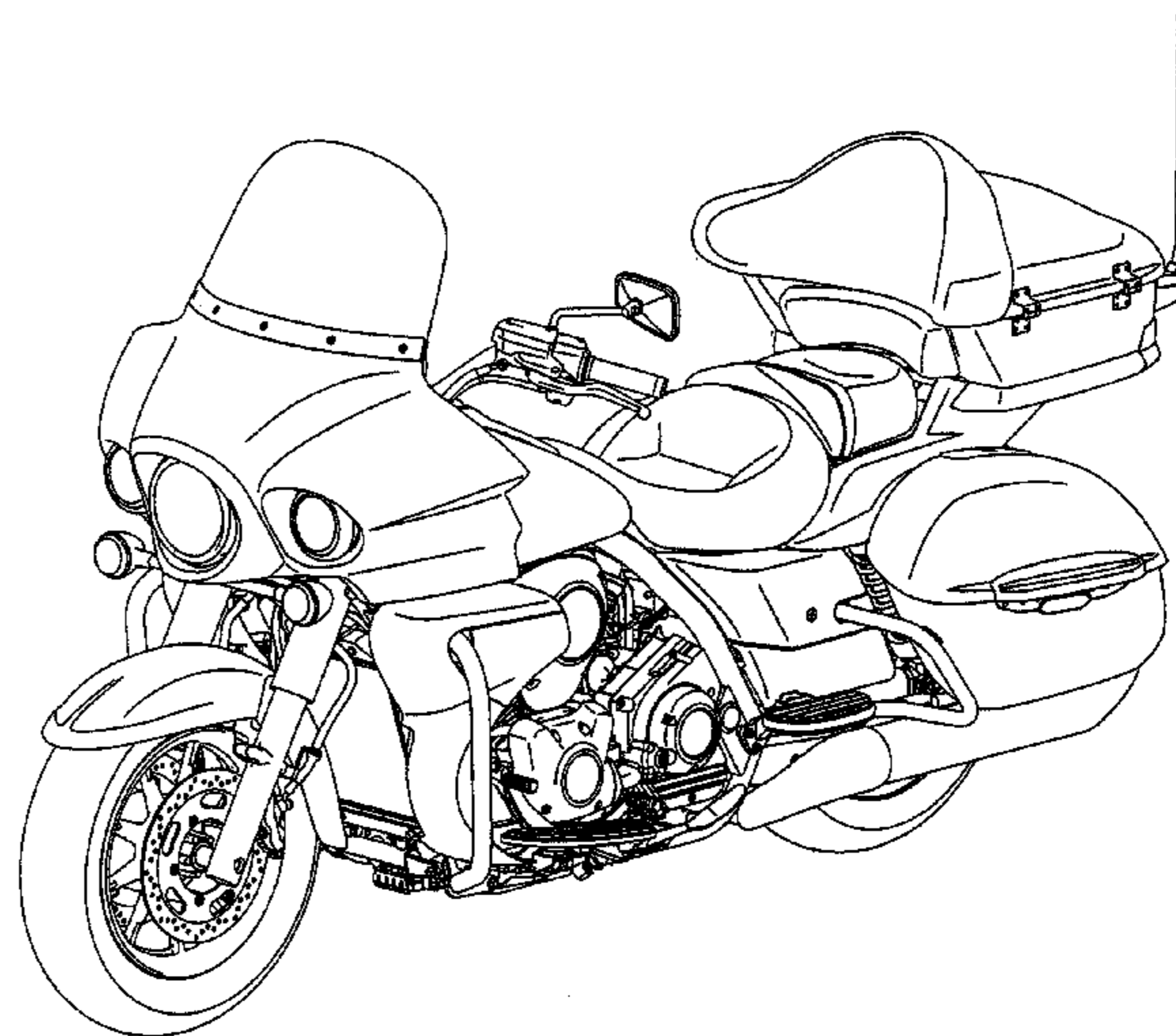
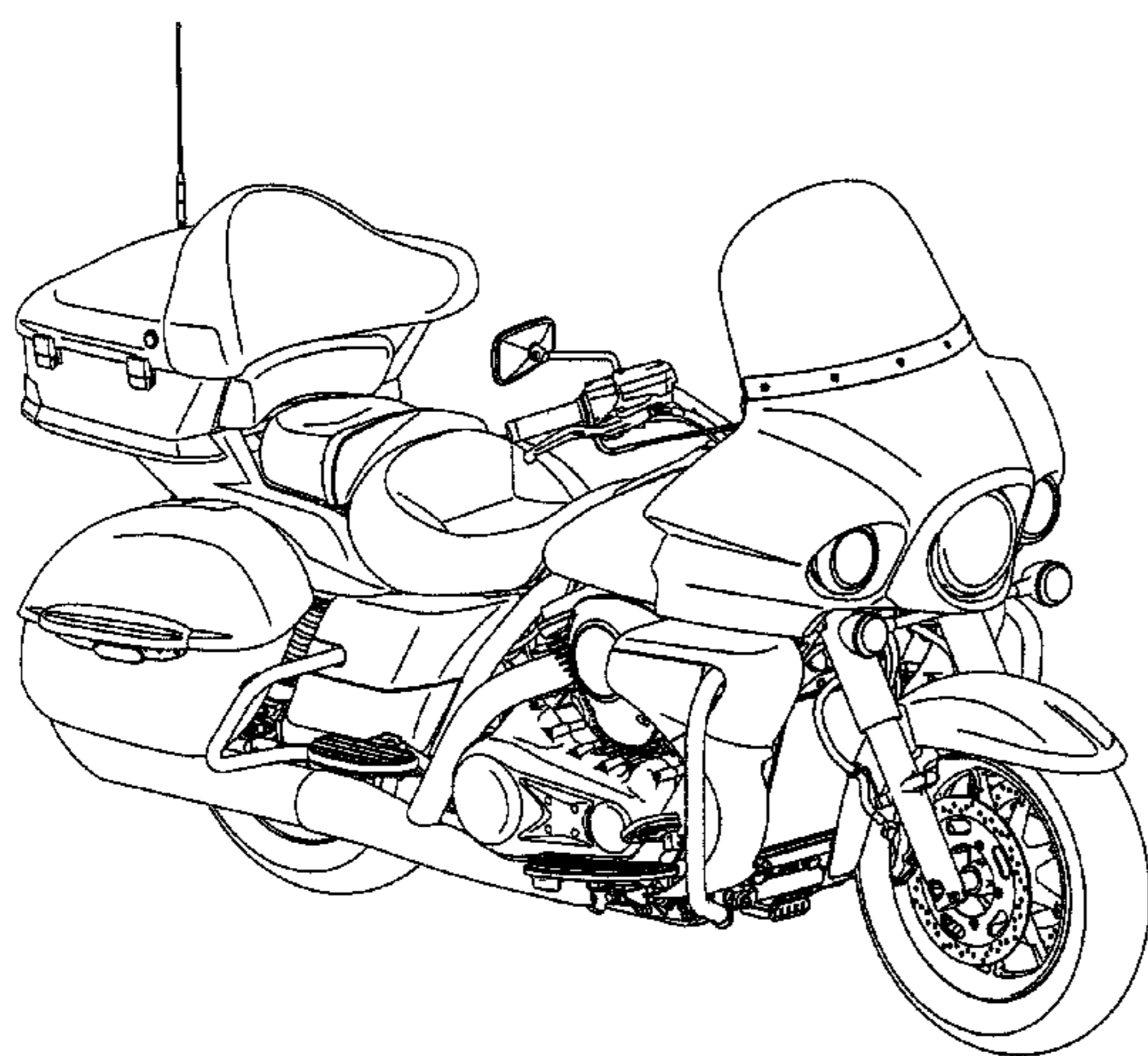

Fig.1

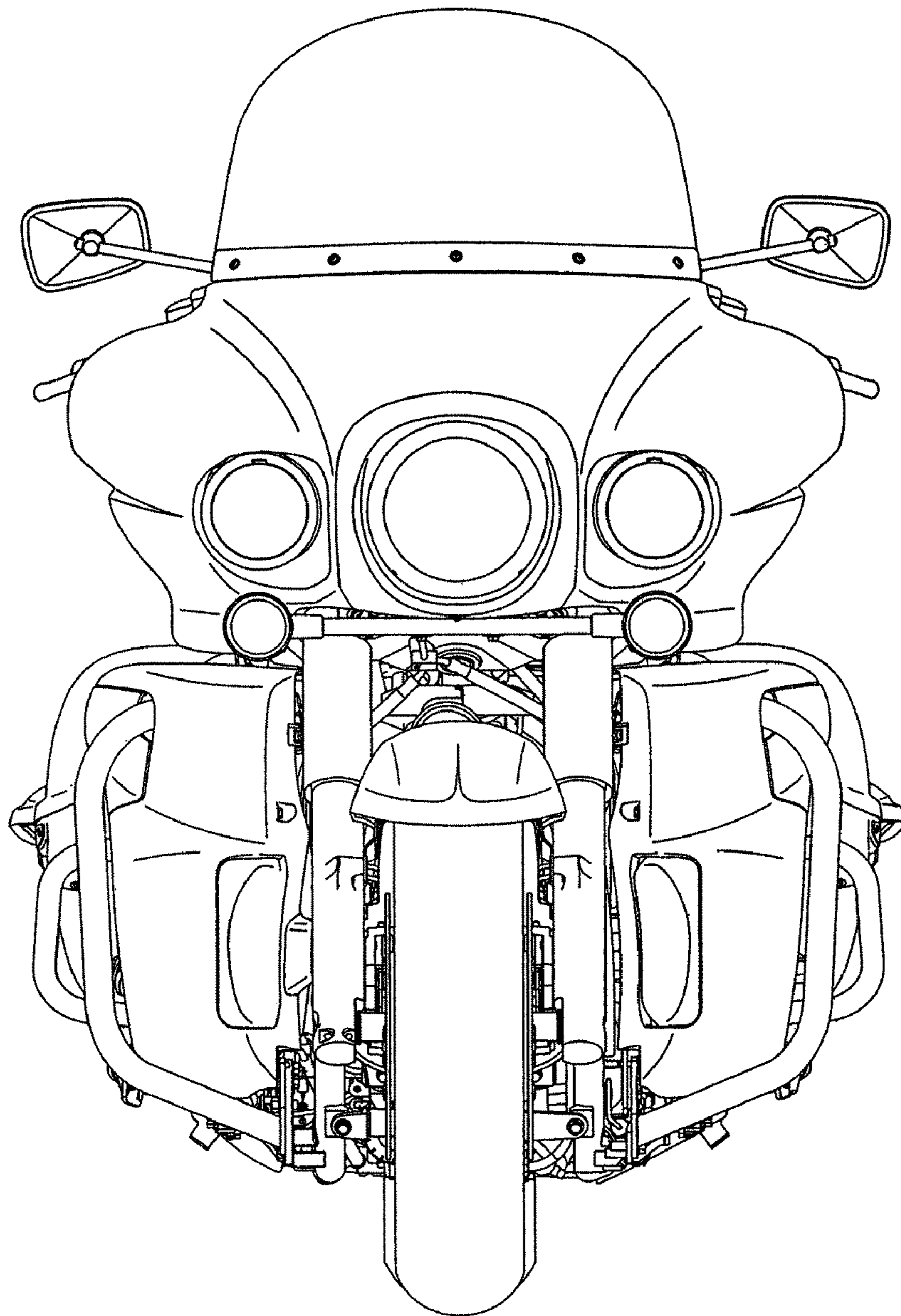
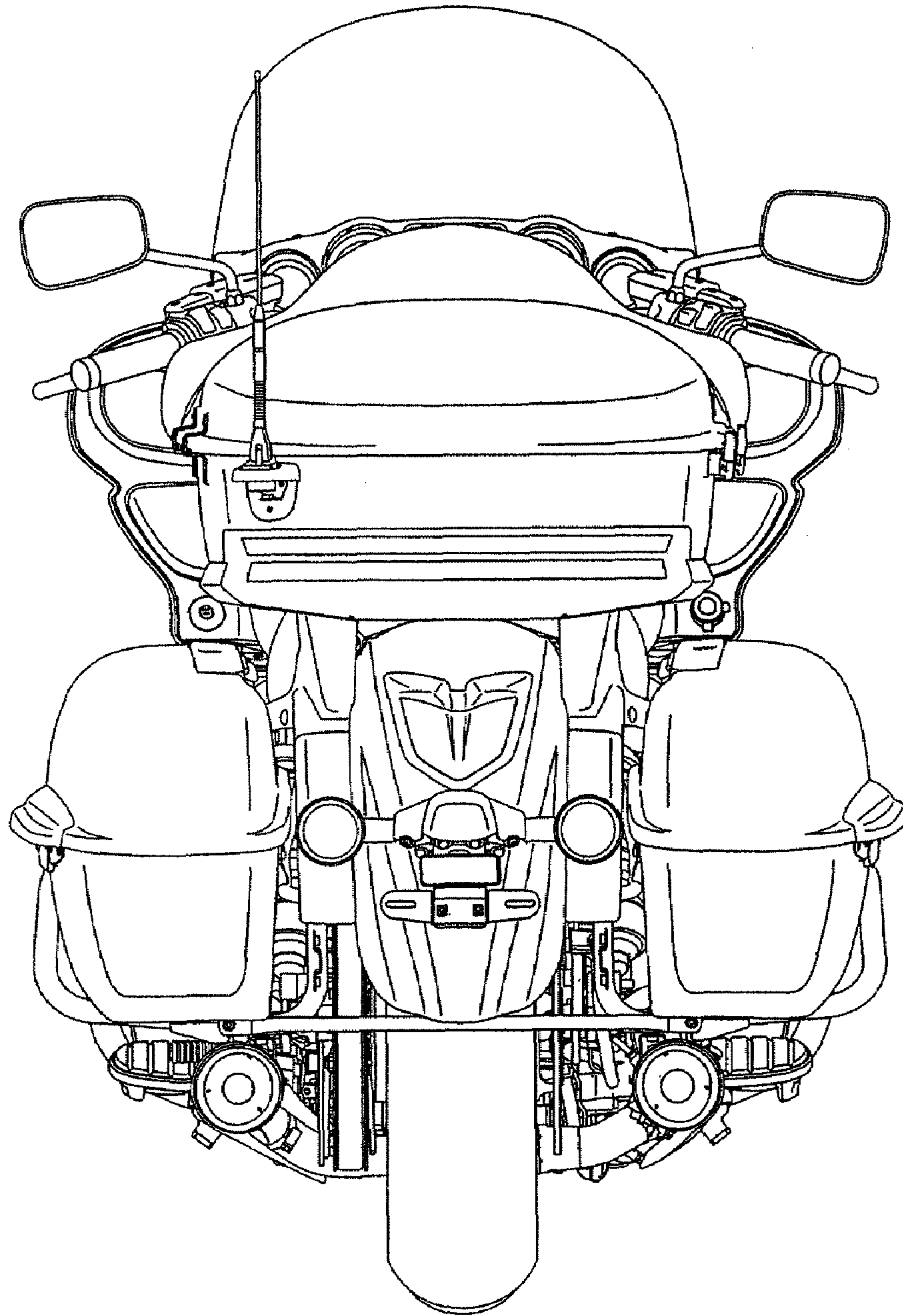

Fig.2



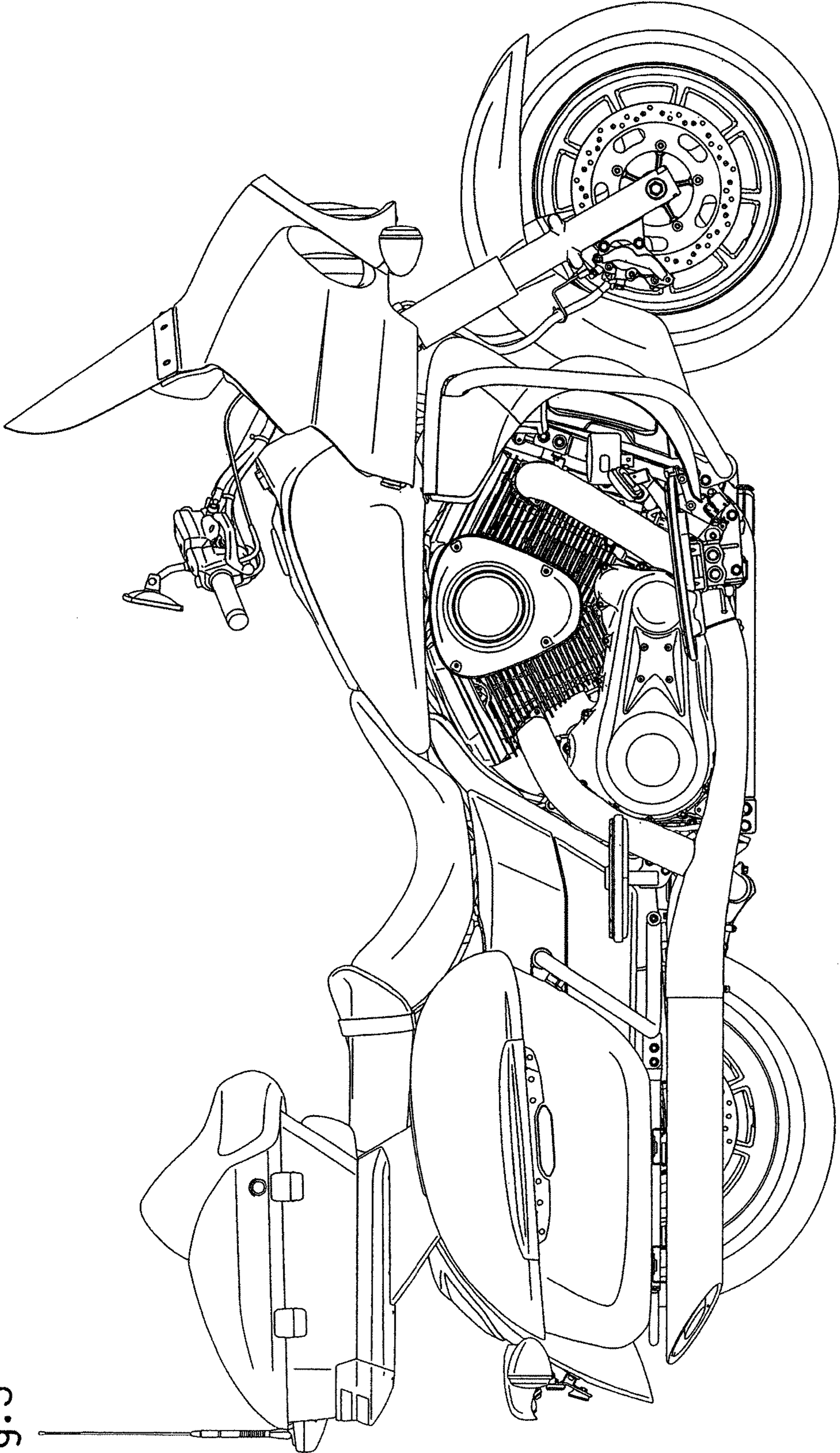

Fig.3

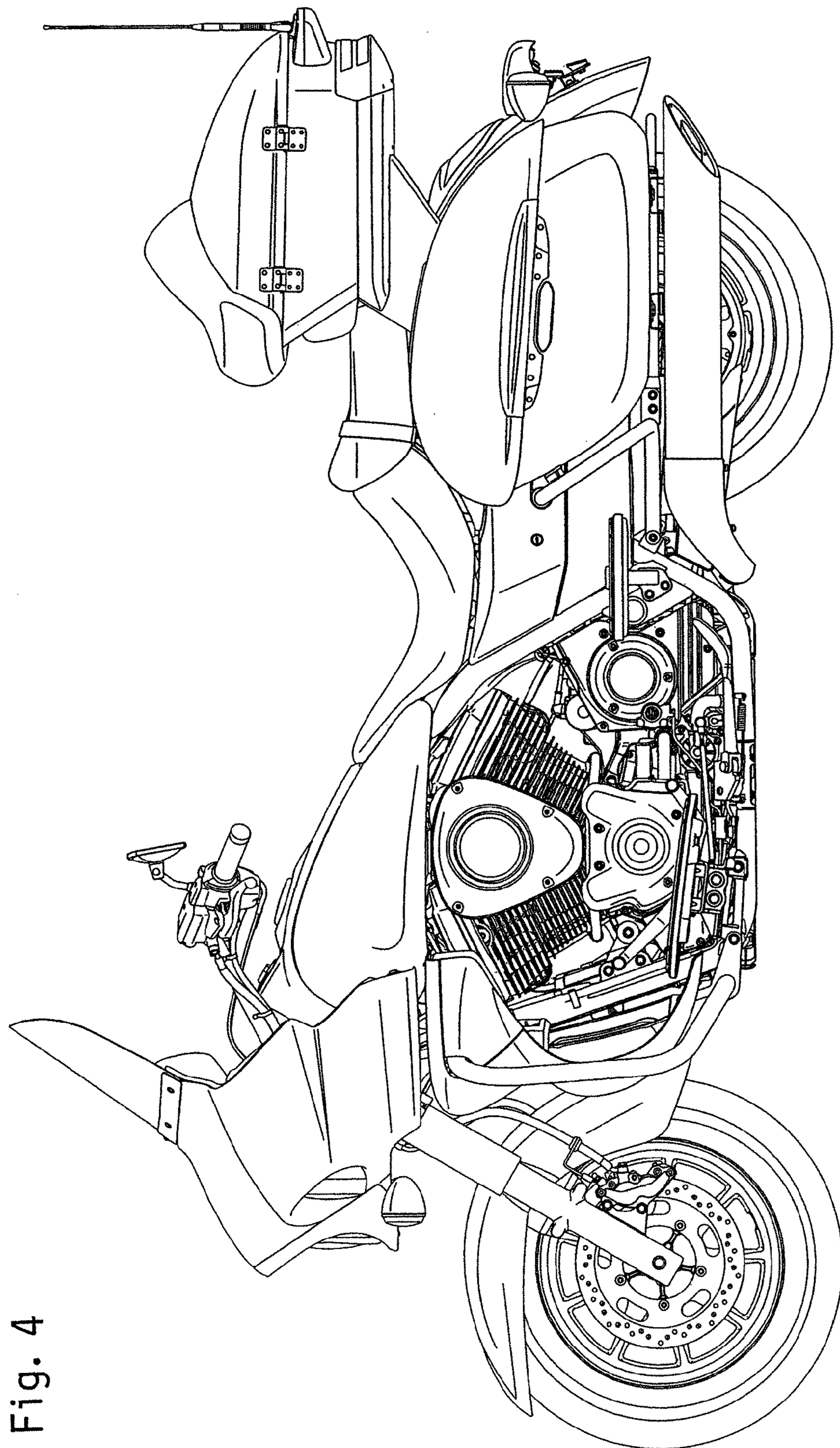

Fig. 4

Fig.5

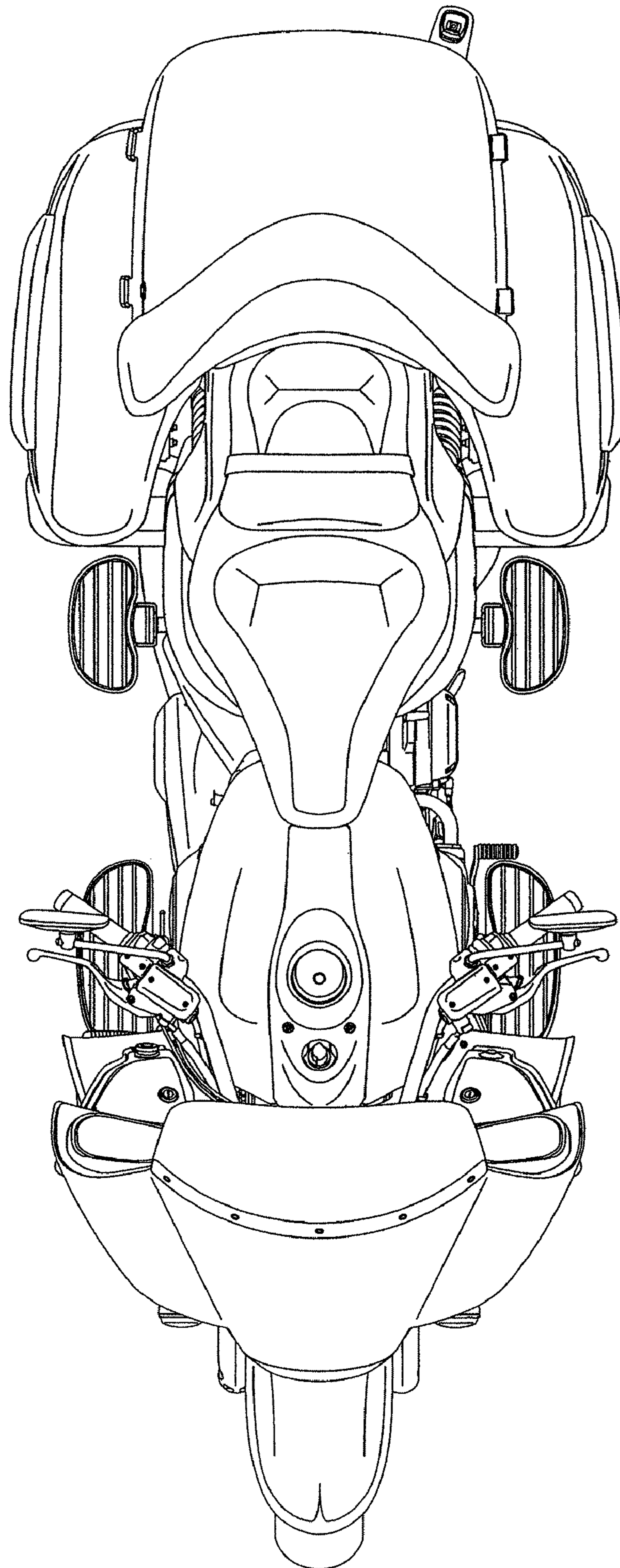
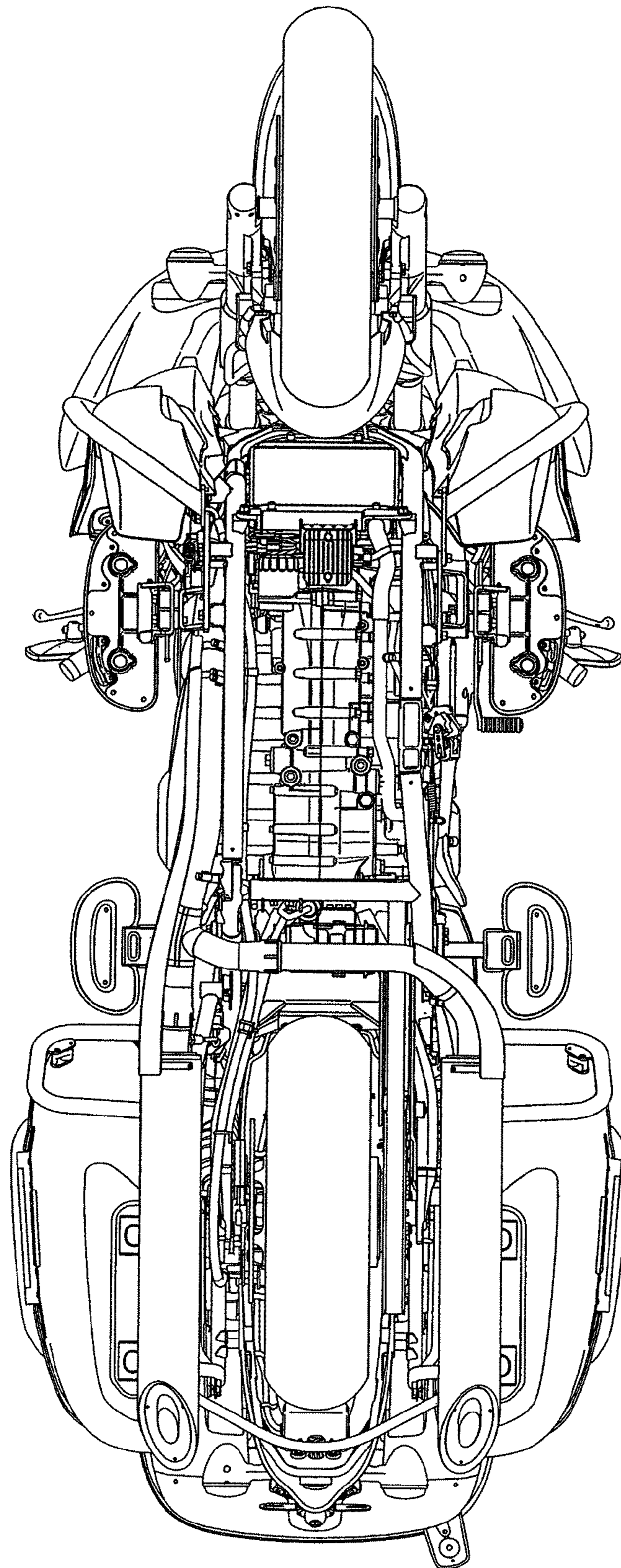

Fig. 6



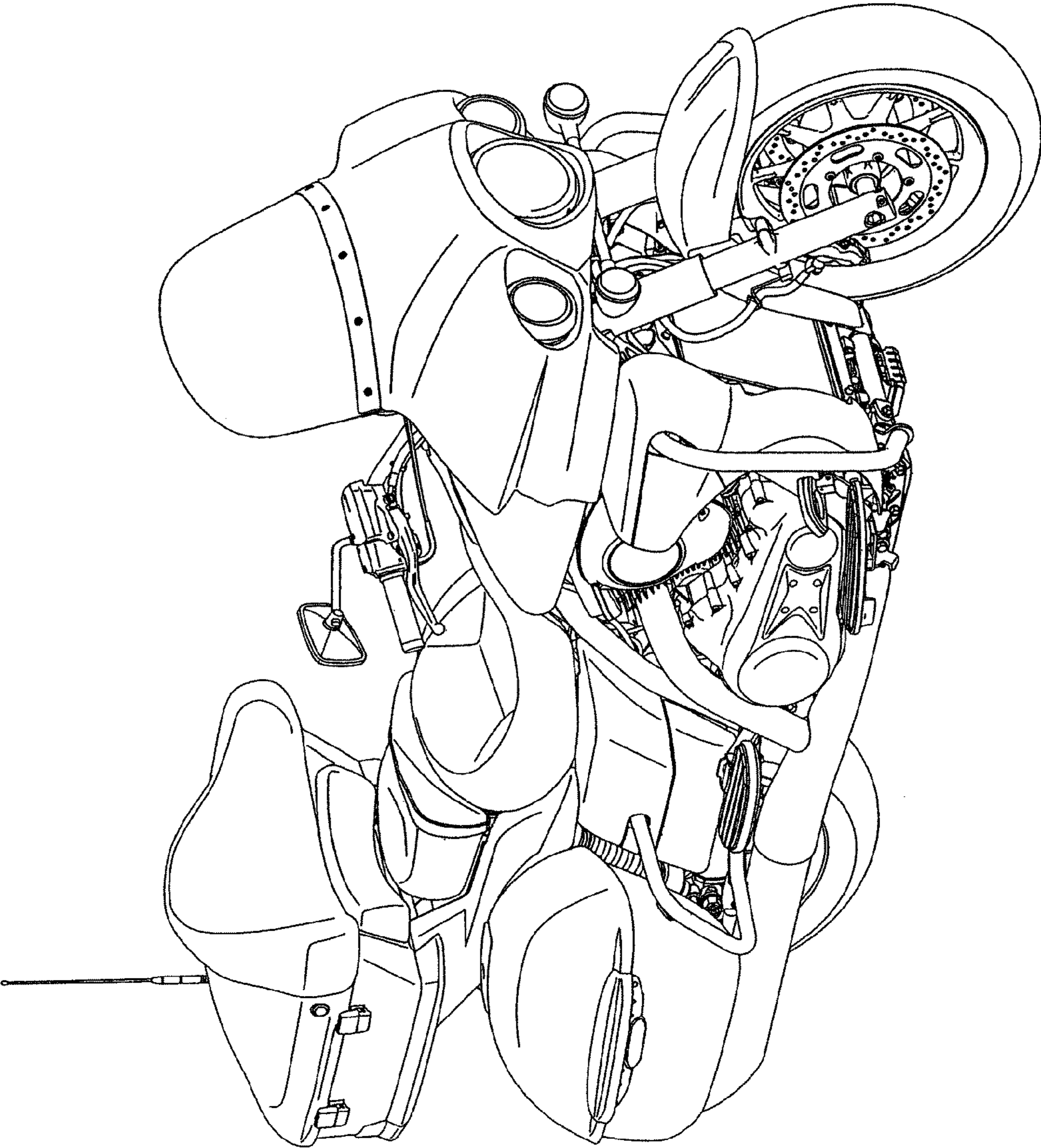

Fig.7

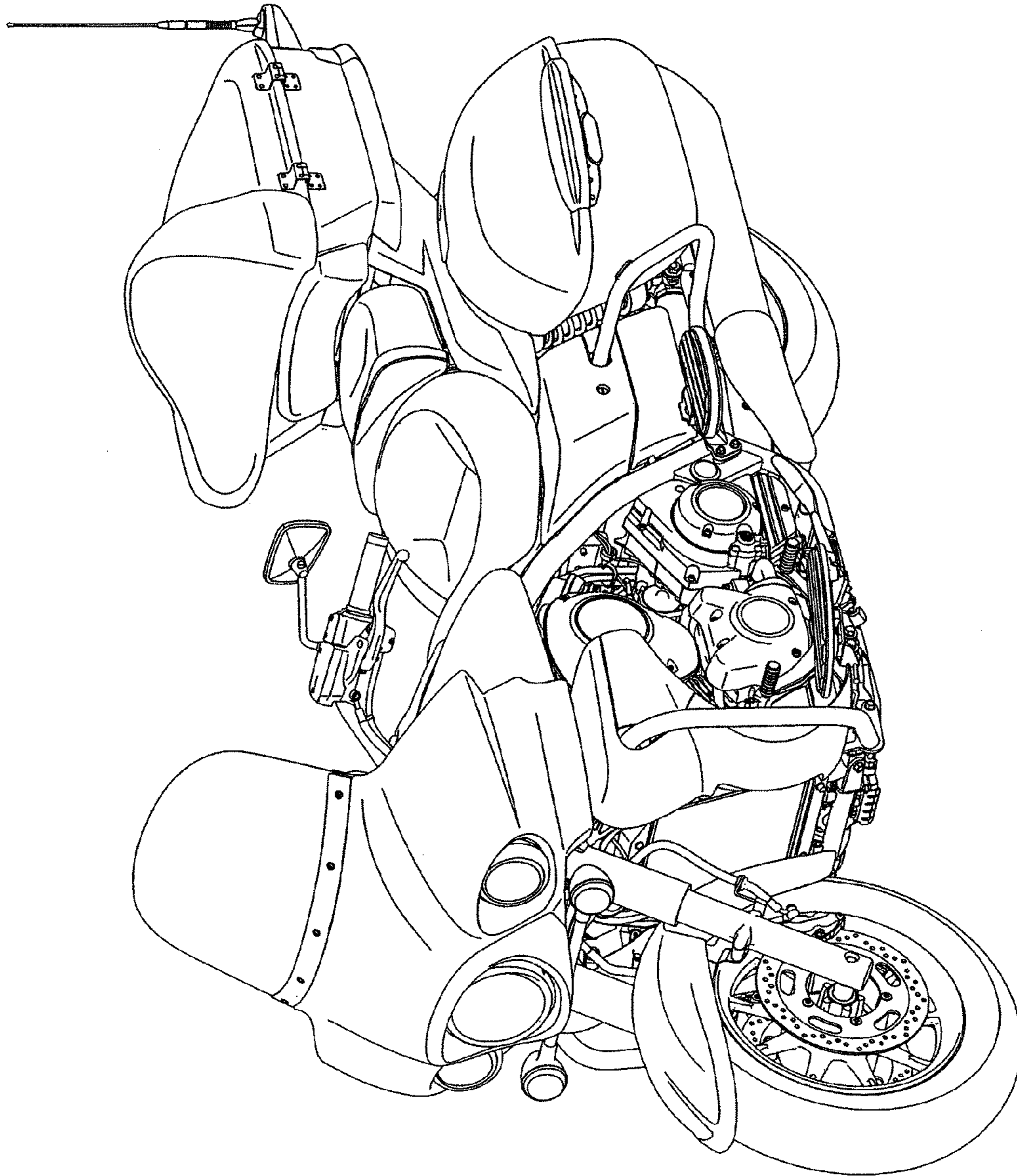

Fig. 8

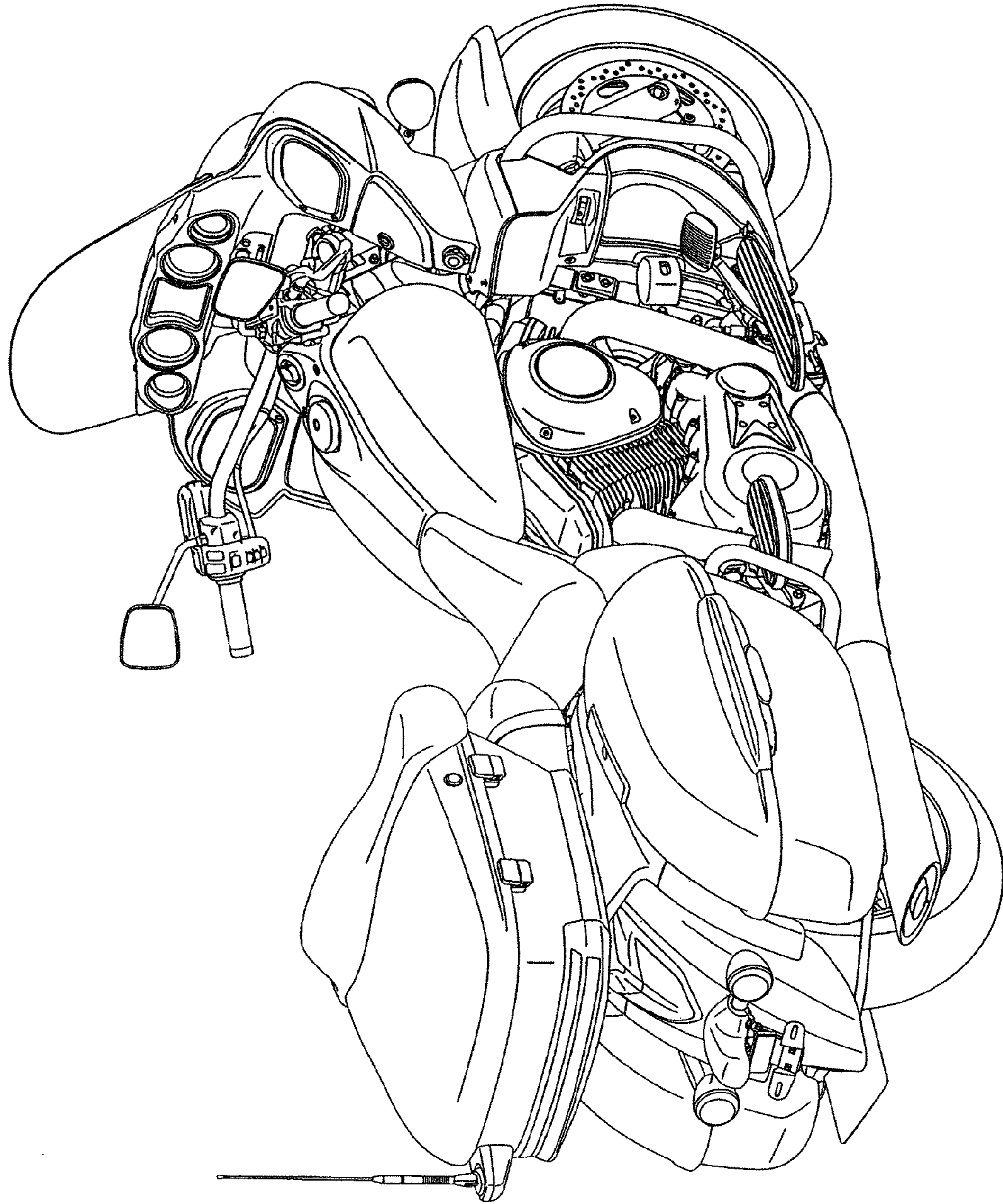

Fig. 9

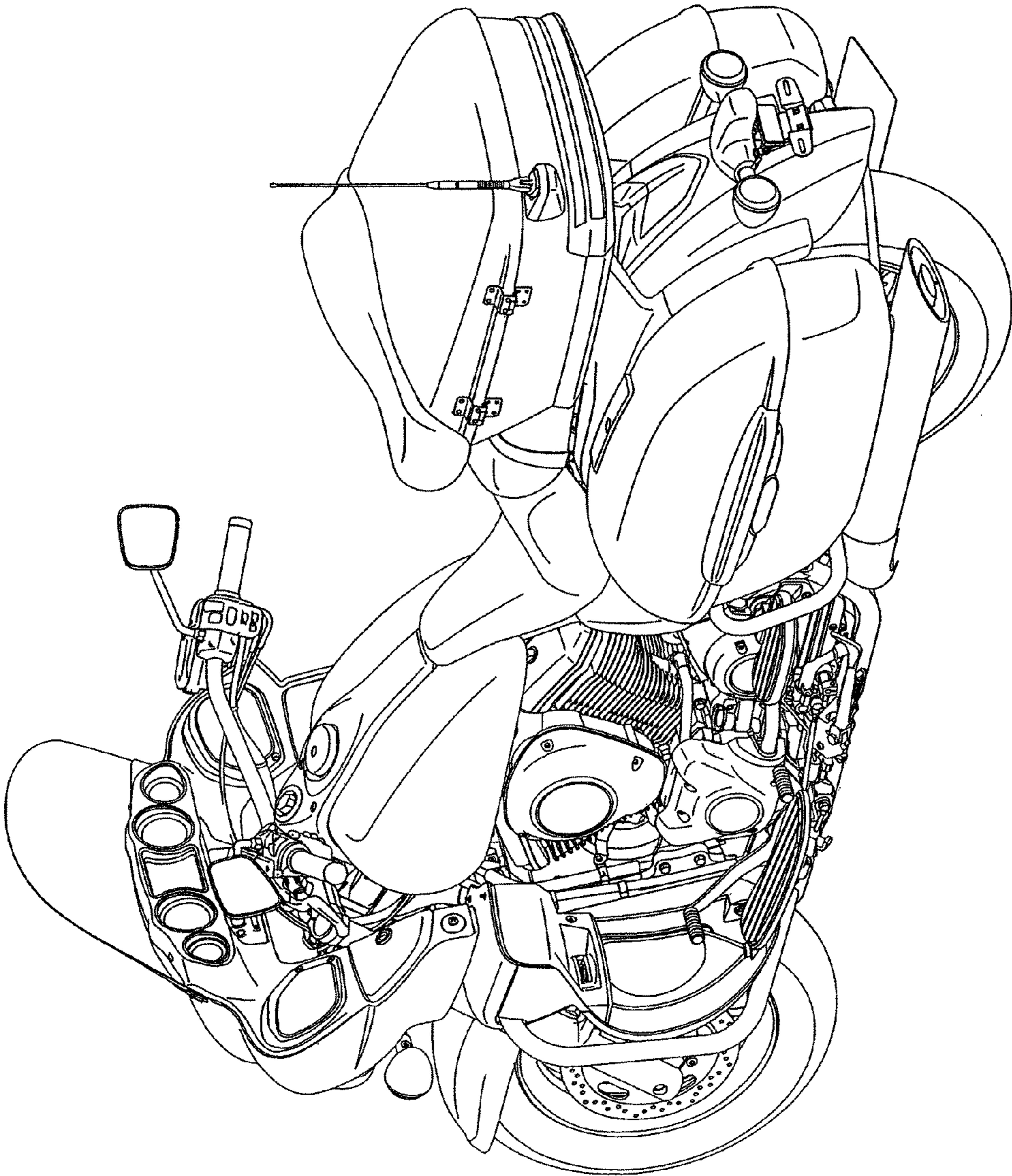

Fig.10

UNITED STATES PATENT AND TRADEMARK OFFICE
CERTIFICATE OF CORRECTION

PATENT NO. : Des. 605,982 S
APPLICATION NO. : 29/333855
DATED : December 15, 2009
INVENTOR(S) : Tanaka et al.

Page 1 of 1

It is certified that error appears in the above-identified patent and that said Letters Patent is hereby corrected as shown below:

On the Cover Page of the Patent under item (56),

OTHER DOCUMENTS, should read:

Japanese Magazine "Motorcycle" published August 1, 2008, No. 8, the excerpt of which is on the Notification of Reasons for Rejection, Page 96 of the magazine, 6 pages.

Signed and Sealed this

Twenty-fifth Day of May, 2010

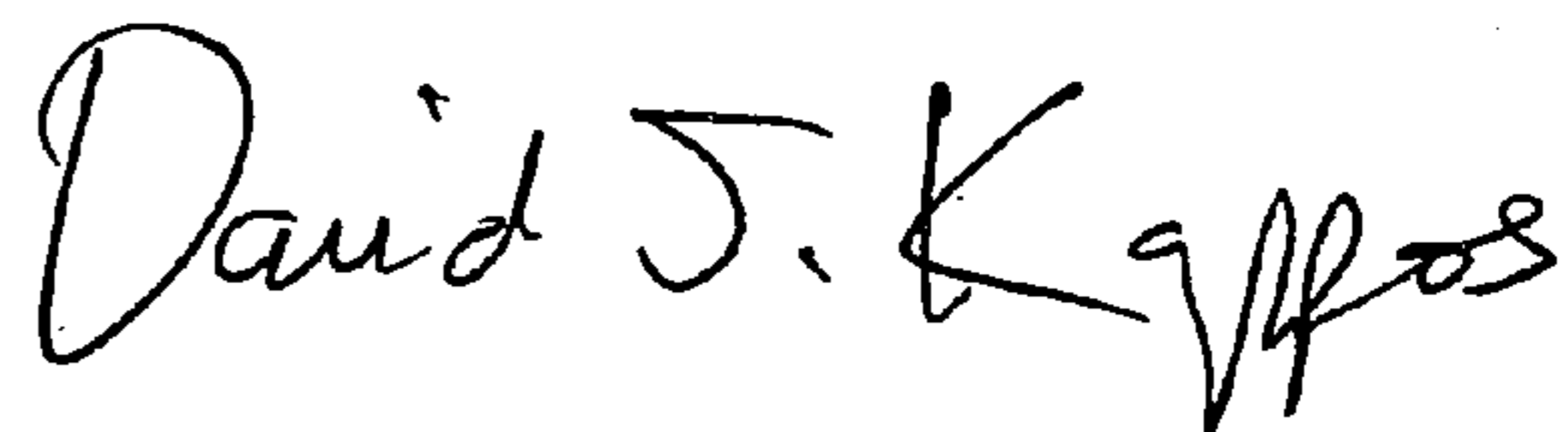
A handwritten signature in black ink that reads "David J. Kappos". The signature is written in a cursive, flowing style.

David J. Kappos
Director of the United States Patent and Trademark Office