

US00D605728S

(12) **United States Design Patent**  
**Ma**

(10) **Patent No.:** **US D605,728 S**

(45) **Date of Patent:** **\*\* Dec. 8, 2009**

(54) **CONTROL UNIT FOR A WATER SOFTENER**

(75) Inventor: **Clint Ma**, Nanjing (CN)

(73) Assignee: **Nanjing Fobrite Environmental Technology Co., Ltd.**, Nanjing (CN)

(\*\*) Term: **14 Years**

(21) Appl. No.: **29/330,652**

(22) Filed: **Jan. 12, 2009**

(51) **LOC (9) Cl.** ..... **23-01**

(52) **U.S. Cl.** ..... **D23/207**

(58) **Field of Classification Search** ..... D23/207,  
D23/209; 210/443-444, 662, 89  
See application file for complete search history.

(56) **References Cited**

U.S. PATENT DOCUMENTS

D205,650 S *	8/1966	King	.....	D23/207
D205,922 S *	10/1966	Moon	.....	D23/207
4,313,825 A *	2/1982	Fleckenstein et al.	.....	210/89
D318,315 S *	7/1991	Sanborn	.....	D23/209
D328,331 S *	7/1992	Drager et al.	.....	D23/207
D336,051 S *	6/1993	Drager et al.	.....	D10/101

\* cited by examiner

*Primary Examiner*—Robin V Webster

(74) *Attorney, Agent, or Firm*—Fitch, Even, Tabin & Flannery

(57) **CLAIM**

I claim the ornamental design for a control unit for a water softener, as shown and described.

**DESCRIPTION**

FIG. 1 is a perspective view of a control unit in accordance with my new design, the broken lines of the control unit are for illustrative purposes only and form no part of the claimed design;

FIG. 2 is a front elevation view of the control unit of FIG. 1;

FIG. 3 is a rear elevation view of the control unit of FIG. 1;

FIG. 4 is a left side elevation view of the control unit of FIG. 1;

FIG. 5 is a right side elevation view of the control unit of FIG. 1;

FIG. 6 is a top view of the control unit of FIG. 1; and,

FIG. 7 is a perspective view of an alternate embodiment of a control unit in accordance with my new design, the broken lines of the control unit are for illustrative purposes only and form no part of the claimed design. This embodiment is similar to the embodiment of FIG. 1 in all respects except that the lower rear portion of the control unit is curved rather than being flat as shown in FIG. 3.

**1 Claim, 7 Drawing Sheets**

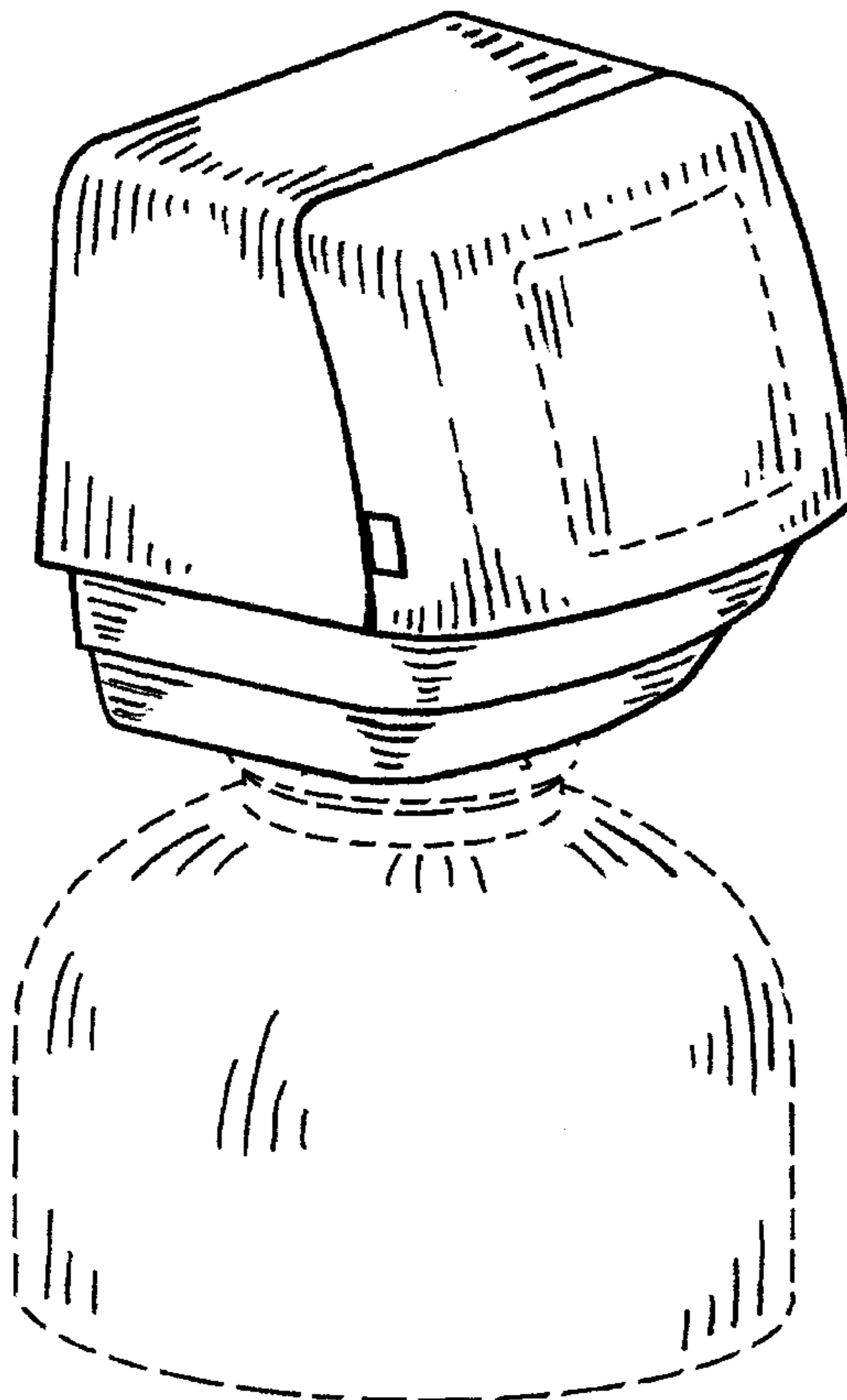

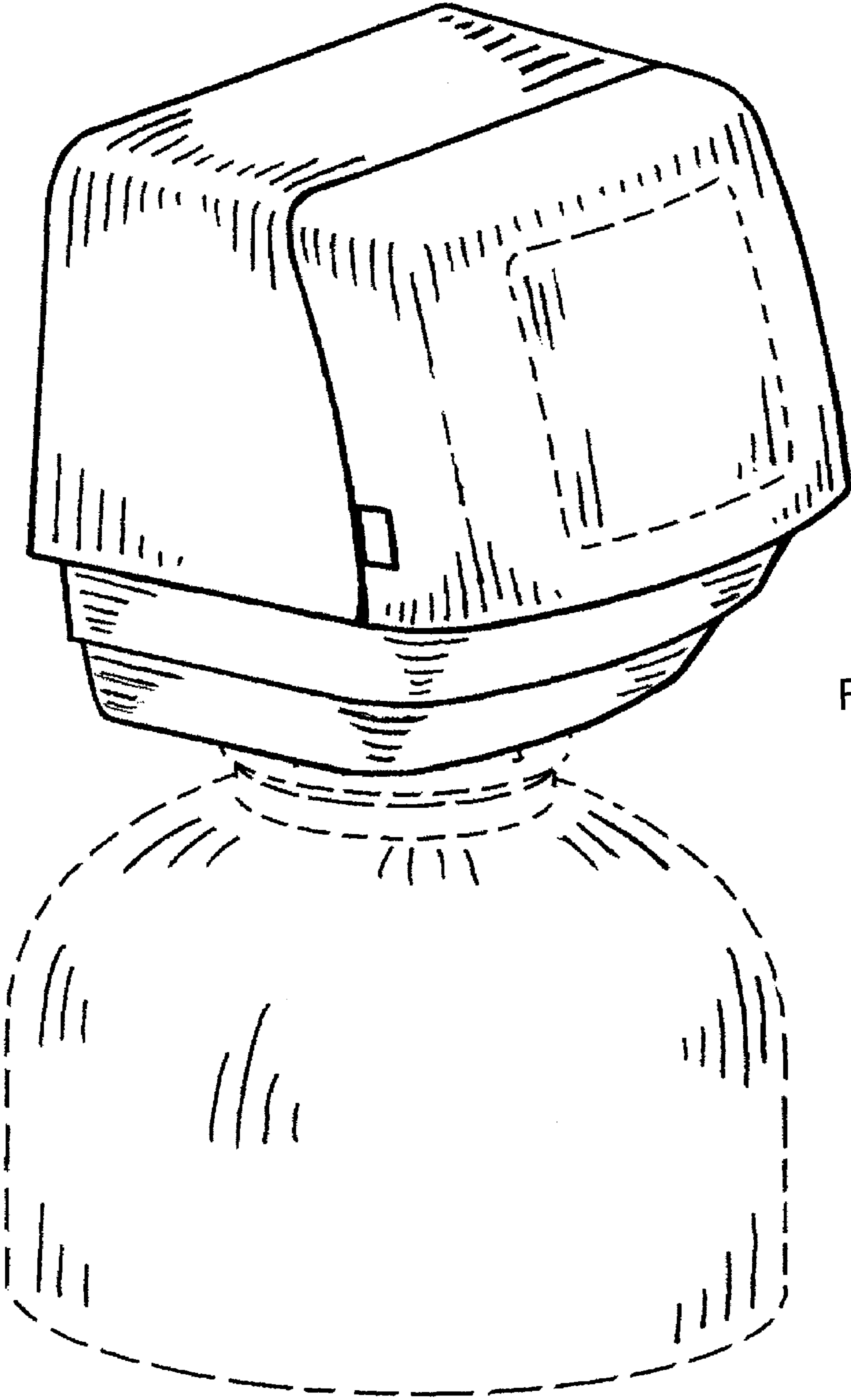

FIG. 1

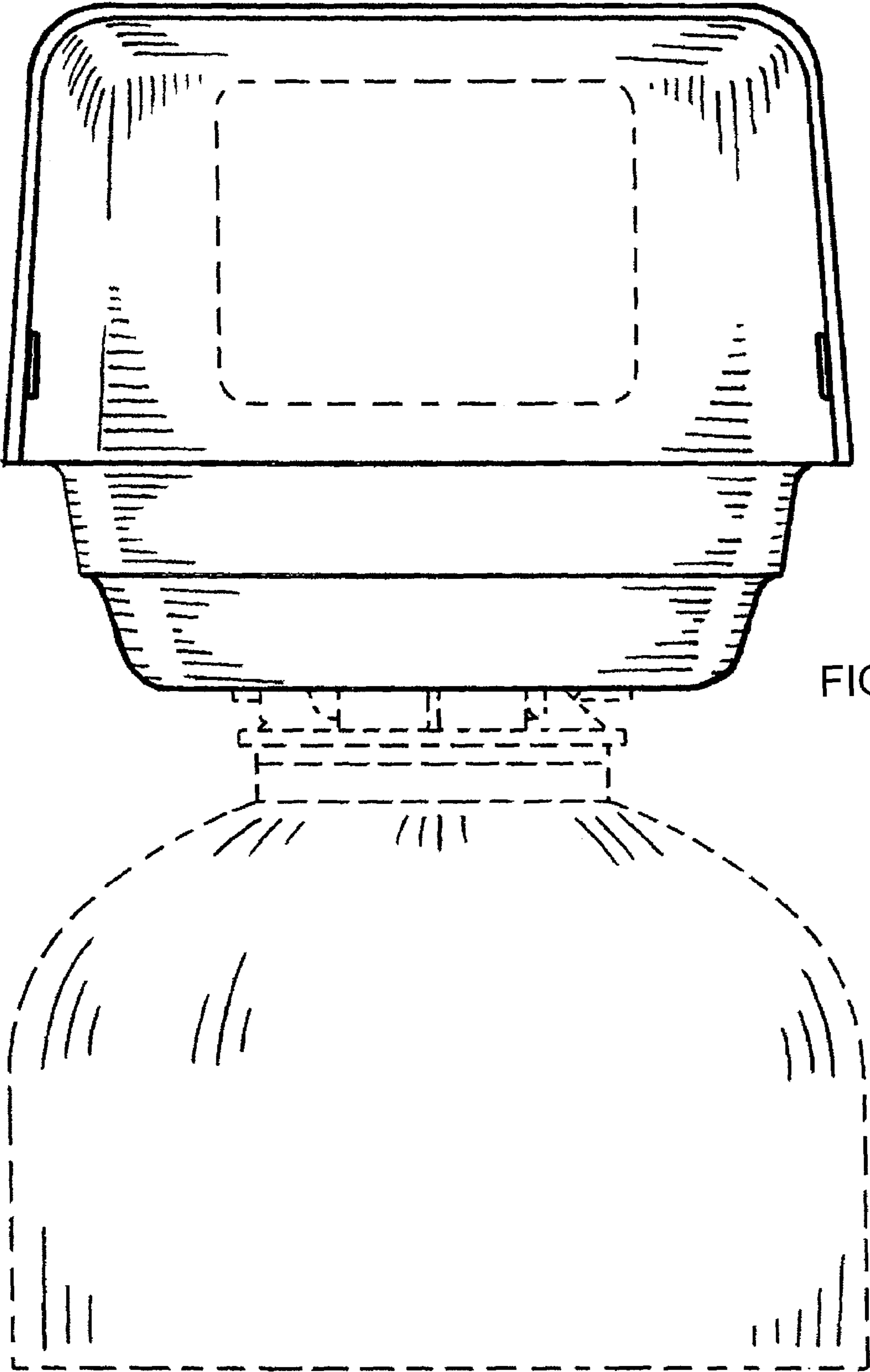

FIG. 2

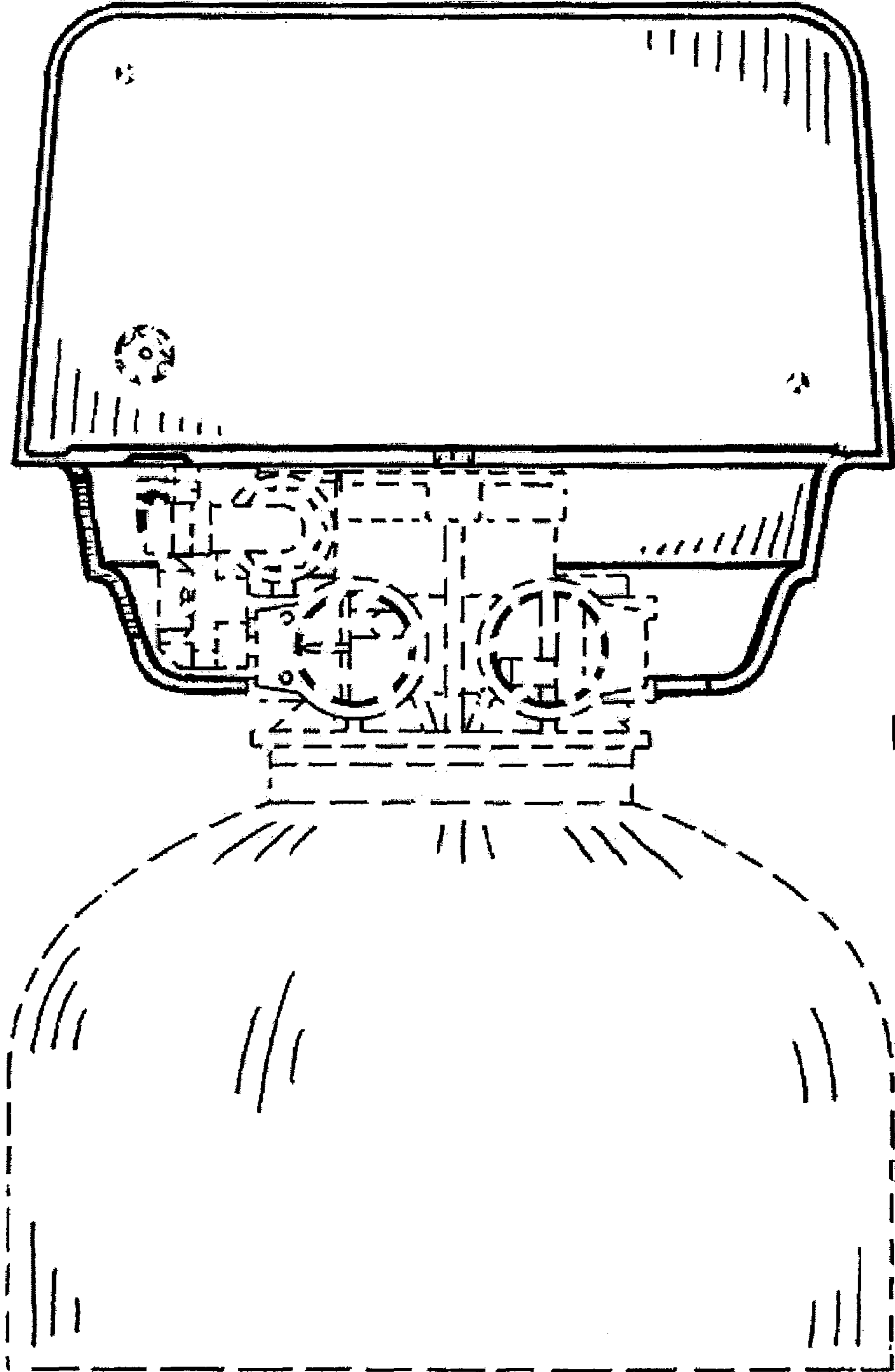

FIG. 3

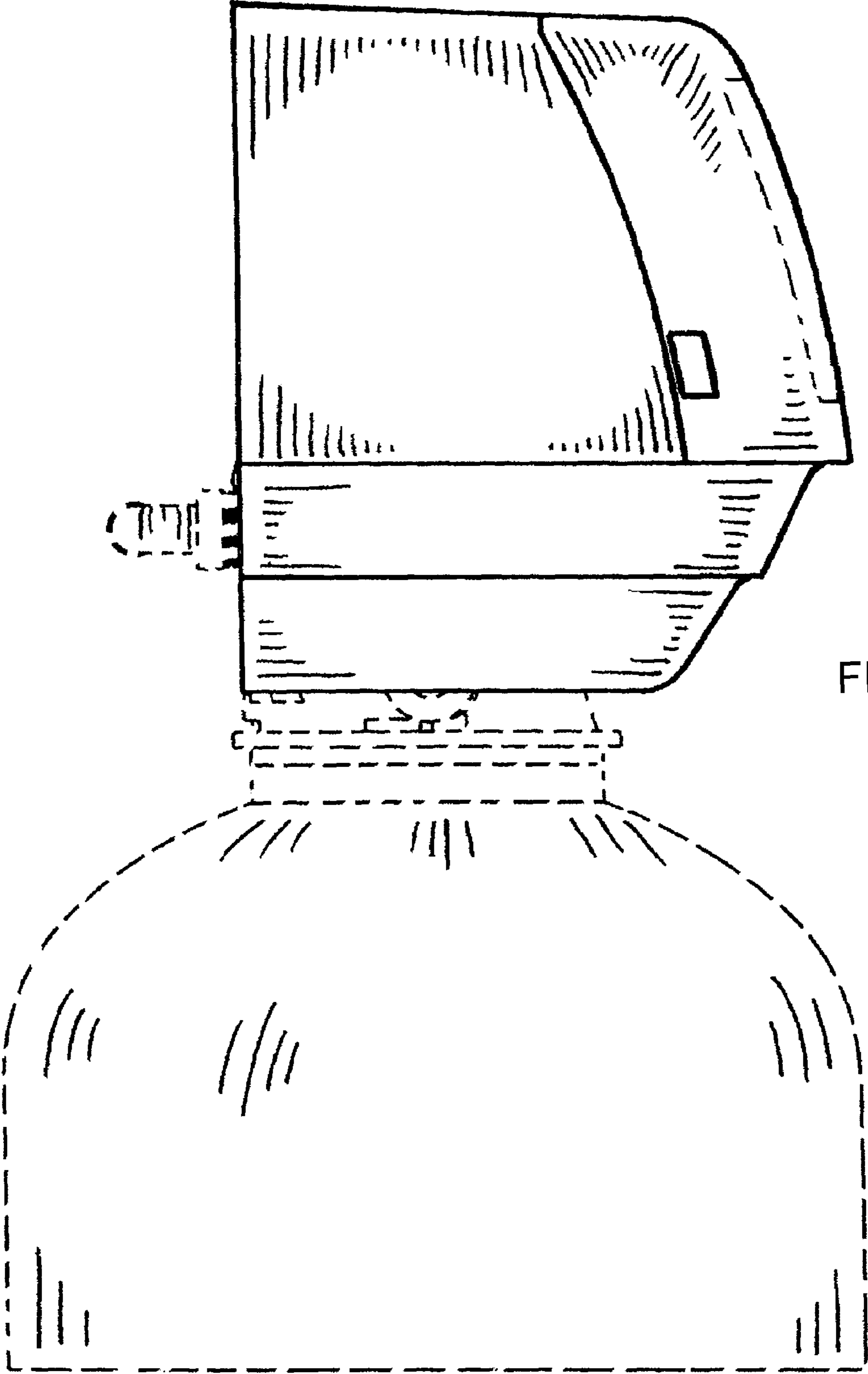

FIG. 4

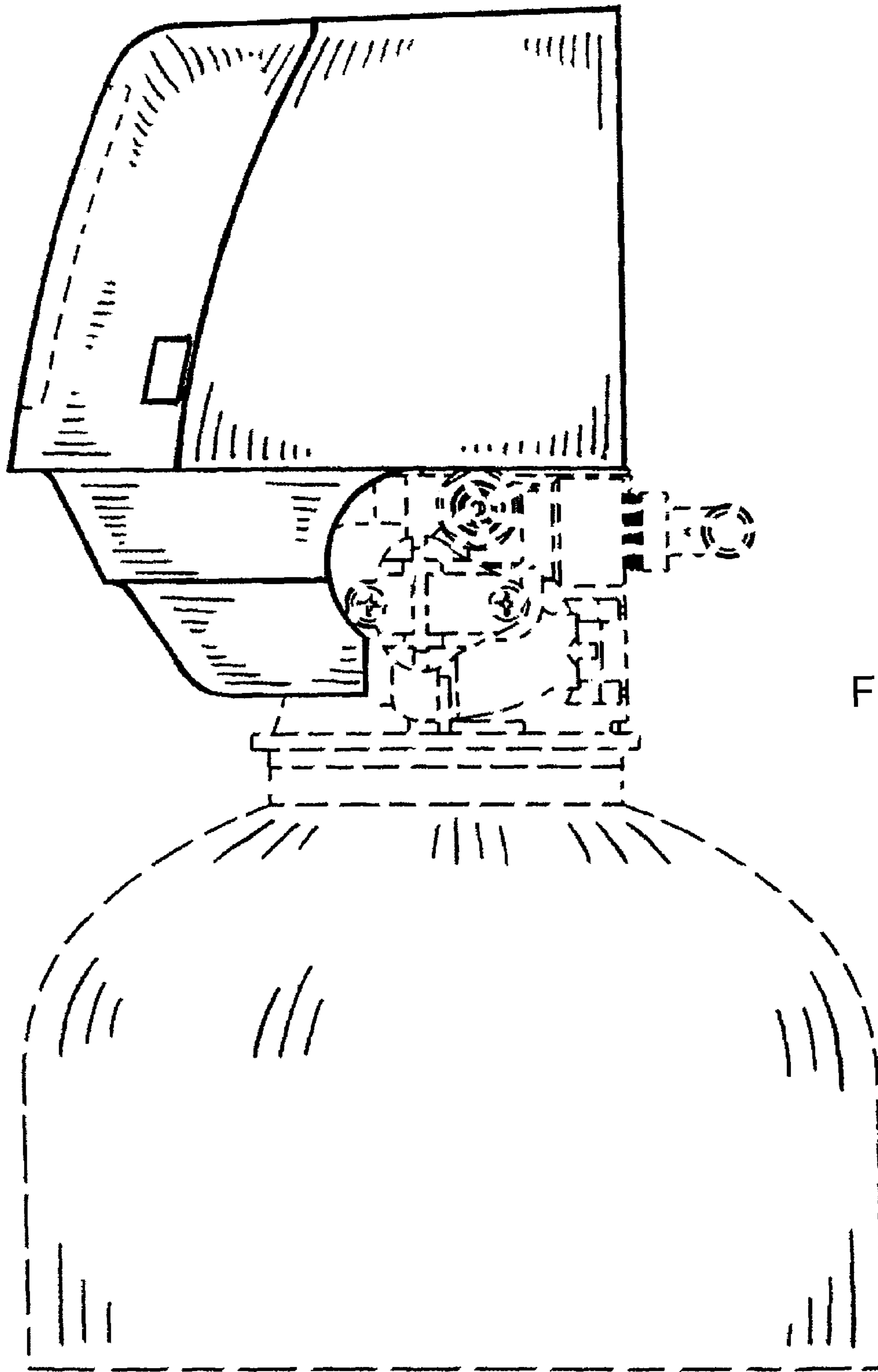

FIG. 5

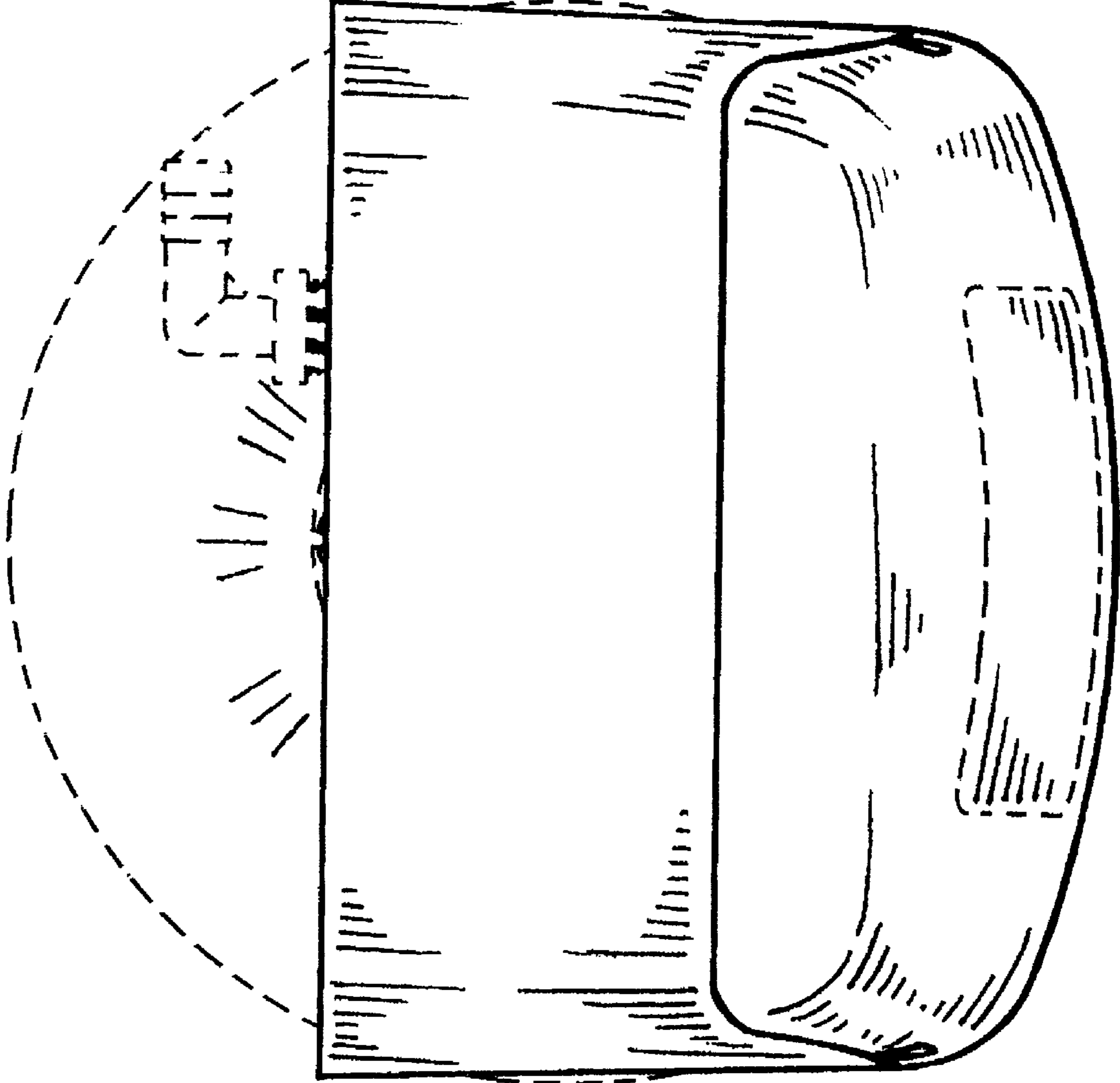

FIG. 6

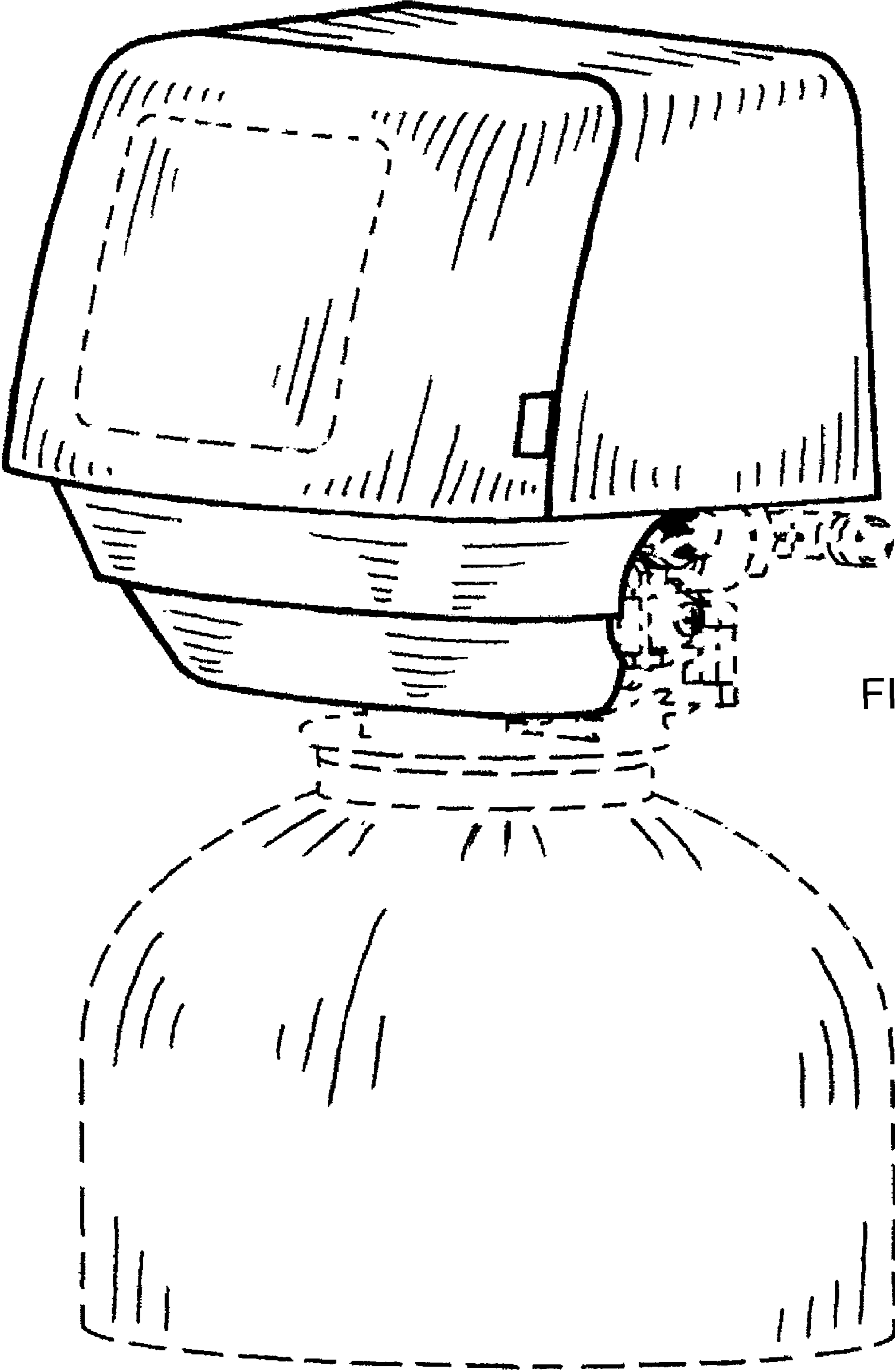

FIG. 7