



US00D605673S

(12) **United States Design Patent**
Rinne

(10) **Patent No.:** **US D605,673 S**
(45) **Date of Patent:** **** Dec. 8, 2009**

(54) **ROTOR MODULE**

2006/0279148 A1* 12/2006 Baumgartner et al. 310/90

(75) Inventor: **Antti Rinne**, Espoo (FI)

FOREIGN PATENT DOCUMENTS

(73) Assignee: **Outotec Oyj**, Espoo (FI)

WO WO 2006/037843 4/2006

(**) Term: **14 Years**

* cited by examiner

(21) Appl. No.: **29/286,816**

Primary Examiner—Sandra Snapp

Assistant Examiner—Patricia Palasik

(22) Filed: **May 18, 2007**

(74) *Attorney, Agent, or Firm*—Merchant & Gould P.C.

(30) **Foreign Application Priority Data**

(57) **CLAIM**

Nov. 22, 2006 (EM) 000630249

The ornamental design for a rotor module, as shown and described.

(51) **LOC (9) Cl.** **15-09**

(52) **U.S. Cl.** **D15/143**

(58) **Field of Classification Search** D15/122,
D15/147–149, 199; 165/4, 8, 10; 209/164,
209/169, 187; 210/219, 221.1, 703; 261/87
See application file for complete search history.

DESCRIPTION

FIG. 1 is a front elevational view of a rotor module.

FIG. 2 is a cross sectional view taken along line 2—2 of FIG. 1.

FIG. 3 is a rear elevational view of FIG. 1.

FIG. 4 is a right side view of FIG. 1, it being understood that the left side is a mirror image.

FIG. 5 is a bottom plan view of FIG. 1.

FIG. 6 is a top plan view of FIG. 1.

FIG. 7 is rear perspective of a rotor module of FIG. 1 with three other similar rotor modules drawn with broken lines, all four rotor modules forming together a rotor.

FIG. 8 is a front elevational view of a second embodiment of a rotor module.

FIG. 9 is a cross sectional view taken along line 9—9 of FIG. 8.

FIG. 10 is a rear elevational view of FIG. 8.

FIG. 11 is a right side view of FIG. 8, it being understood that the left side is a mirror image.

FIG. 12 is a bottom plan view of FIG. 8.

FIG. 13 is a top plan view of FIG. 8.

FIG. 14 is rear perspective of a rotor module of FIG. 8 with four other similar rotor modules drawn with broken lines, all five rotor modules forming together a rotor.

(56) **References Cited**

U.S. PATENT DOCUMENTS

2,350,475	A	6/1944	Rabazzana	
D259,346	S	5/1981	DeHaven	
D263,229	S	3/1982	Nitz et al.	
D282,340	S	1/1986	Lam	
4,800,017	A *	1/1989	Krishnaswamy et al.	210/219
4,968,010	A	11/1990	Odobasic	
5,150,886	A	9/1992	Hamberg et al.	
5,244,097	A *	9/1993	Leiponen et al.	209/169
D361,719	S	8/1995	Walther	
5,615,732	A *	4/1997	Brophy et al.	165/8
D454,384	S	3/2002	Lord	
6,672,369	B1 *	1/2004	Brophy et al.	165/8
6,772,885	B2	8/2004	Bourke	
6,805,243	B1	10/2004	Kallioinen et al.	
6,820,681	B2 *	11/2004	Ohgami et al.	165/10
6,945,408	B2 *	9/2005	Niitti	209/169
7,082,987	B2 *	8/2006	Hamilton	165/9
D533,641	S	12/2006	Singtoroj	
2002/0069836	A1 *	6/2002	Larkin et al.	122/1 A
2004/0112799	A1 *	6/2004	Niitti	209/169
2004/0112835	A1	6/2004	Bourke	

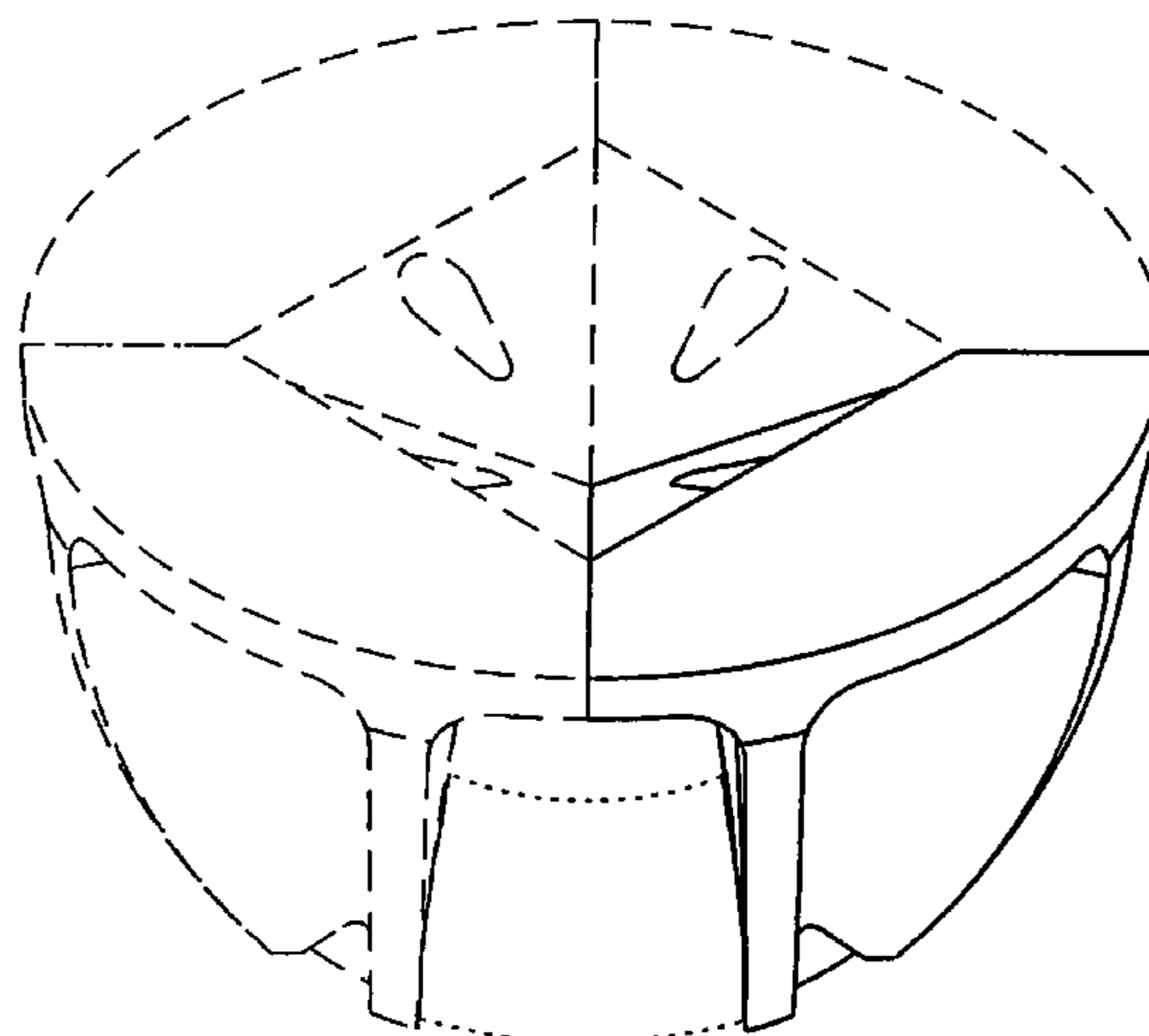

FIG. 15 is a front elevational view of a third embodiment of a rotor module.

FIG. 16 is a cross sectional view taken along line 16—16 of FIG. 15.

FIG. 17 is a rear elevational view of FIG. 15.

FIG. 18 is a right side view of FIG. 15, it being understood that the left side is a mirror image.

FIG. 19 is a bottom plan view of FIG. 15.

FIG. 20 is a top plan view of FIG. 15.

FIG. 21 is rear perspective of a rotor module of FIG. 15 with five other similar rotor modules drawn with broken lines, all six rotor modules forming together a rotor.

FIG. 22 is a front elevational view of a fourth embodiment of a rotor module.

FIG. 23 is a cross sectional view taken along line 23—23 of FIG. 22.

FIG. 24 is a rear elevational view of FIG. 22.

FIG. 25 is a right side view of FIG. 22, it being understood that the left side is a mirror image.

FIG. 26 is a bottom plan view of FIG. 22.

FIG. 27 is a top plan view of FIG. 22; and,

FIG. 28 is rear perspective of a rotor module of FIG. 22 with seven other similar rotor modules drawn with broken lines, all eight rotor modules forming together a rotor.

The broken lines show environment and do not form a part of the claimed design.

1 Claim, 16 Drawing Sheets

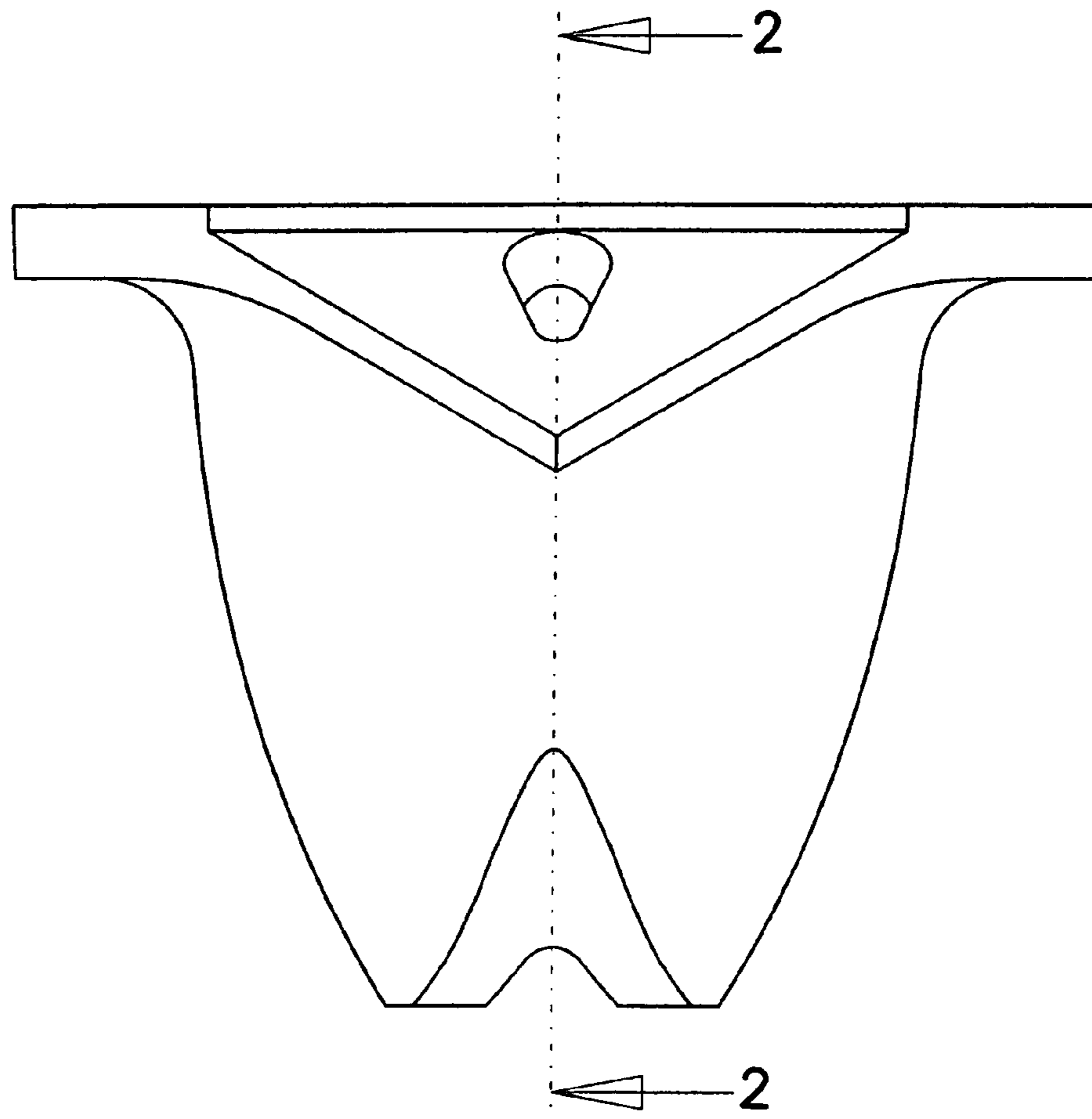

FIG. 1

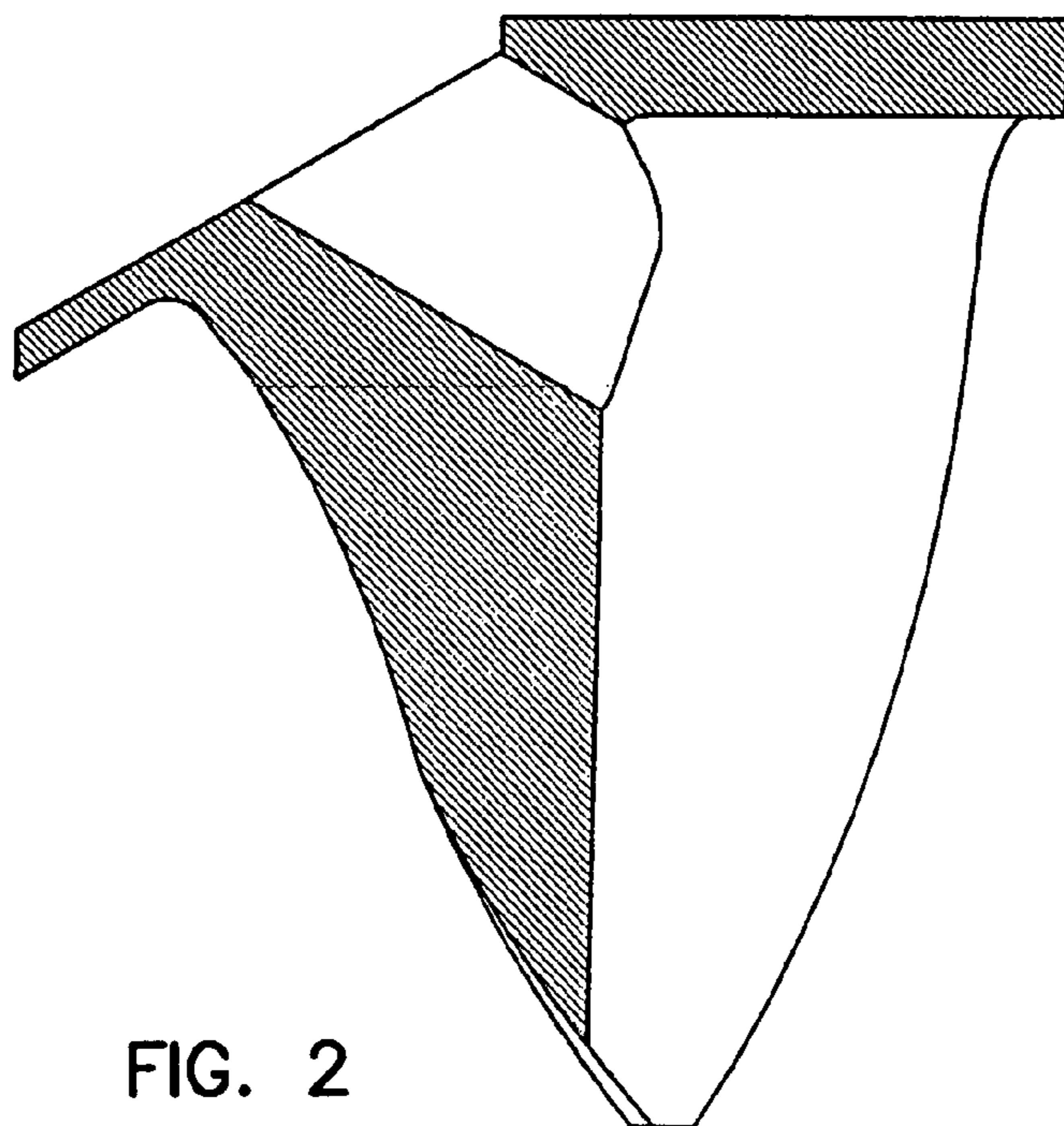

FIG. 2

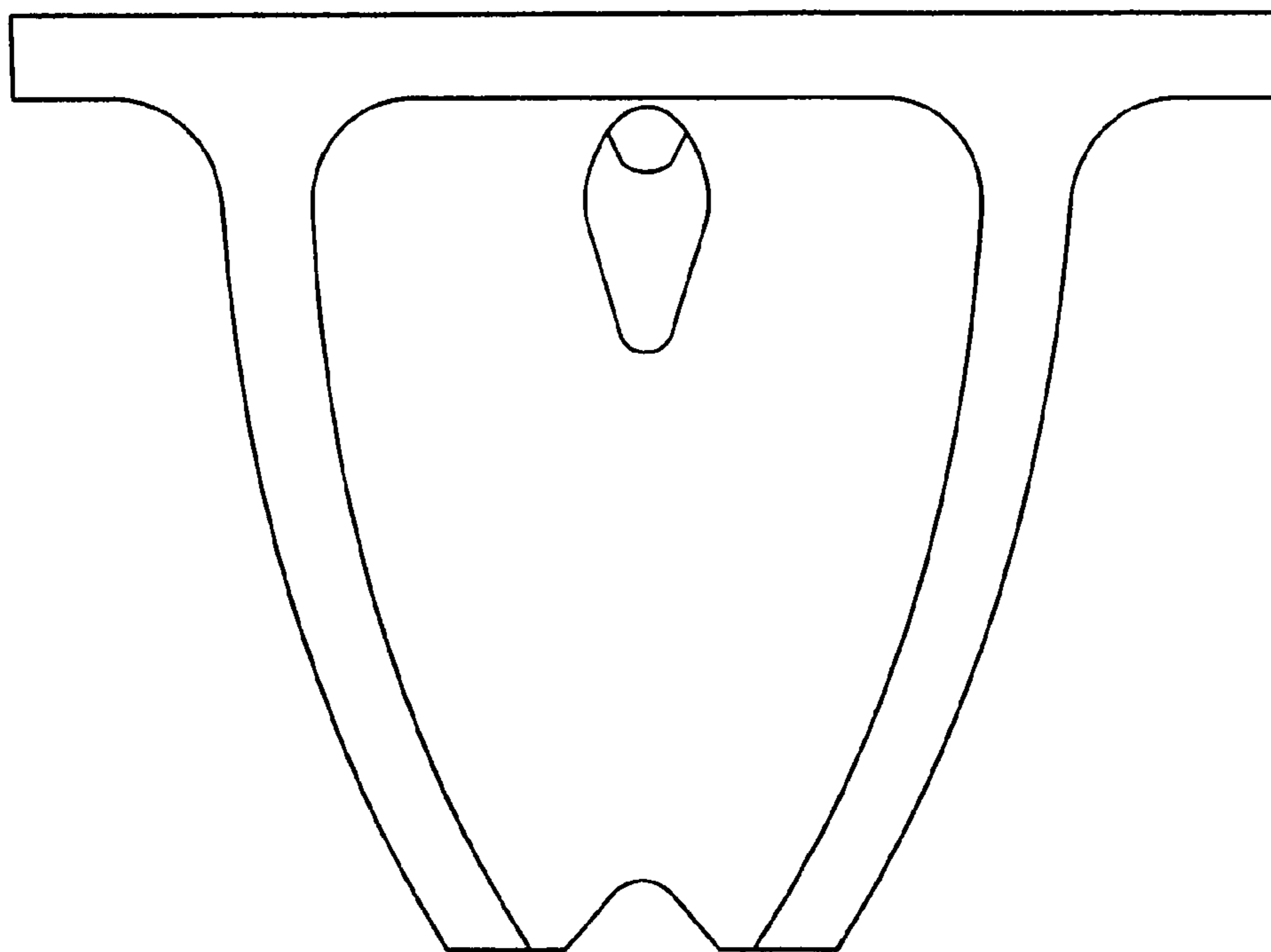

FIG. 3

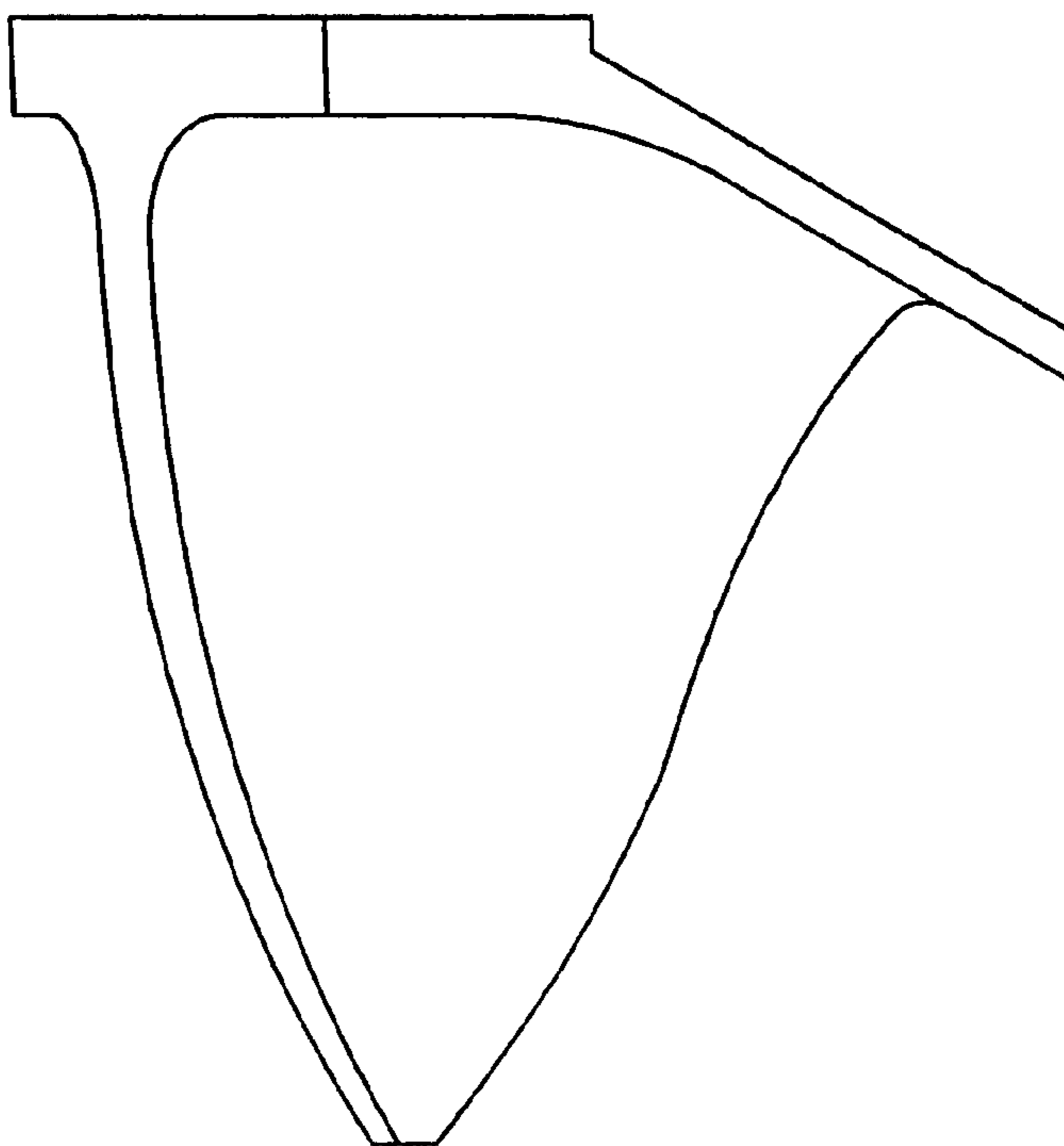

FIG. 4

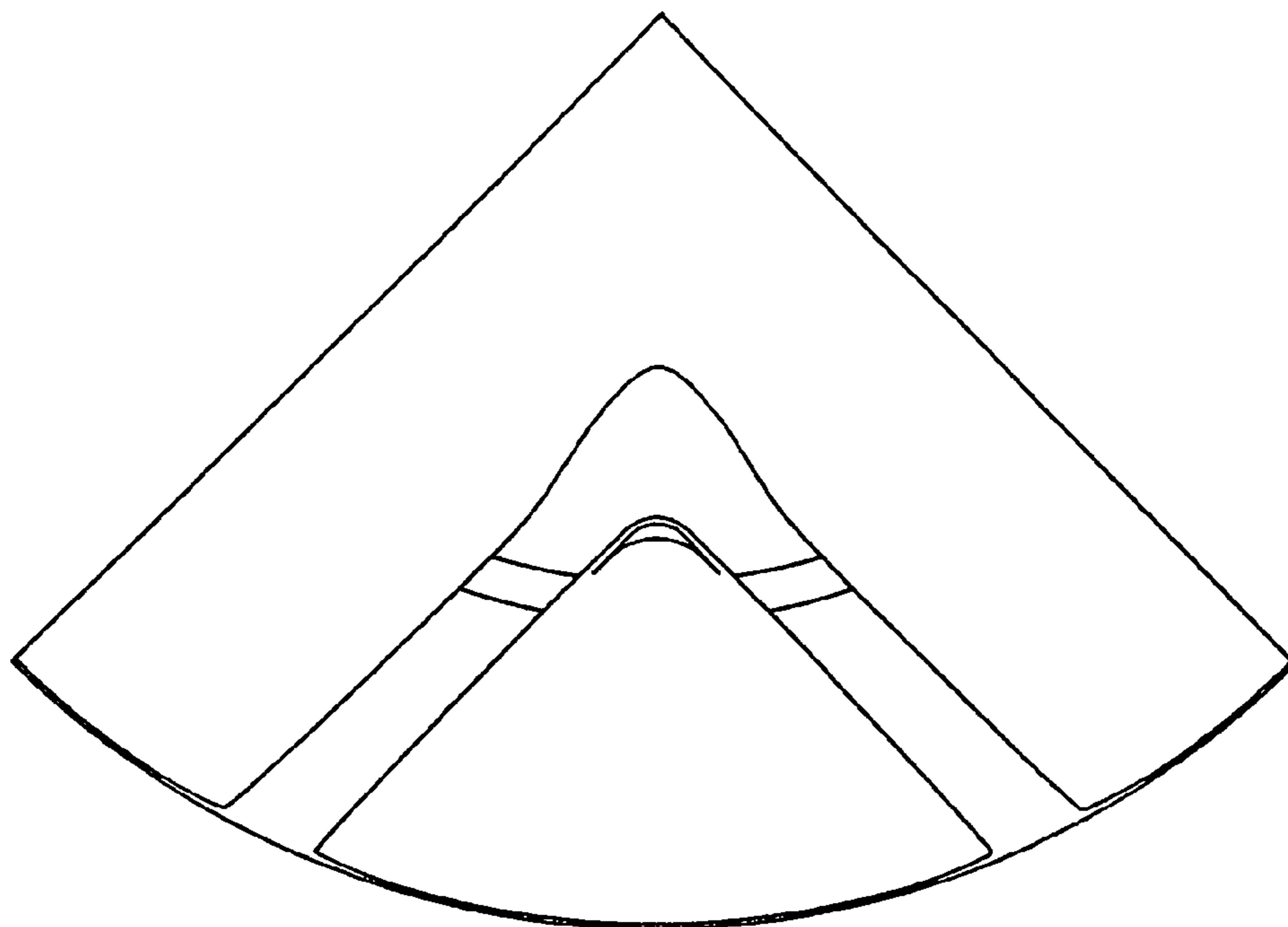

FIG. 5

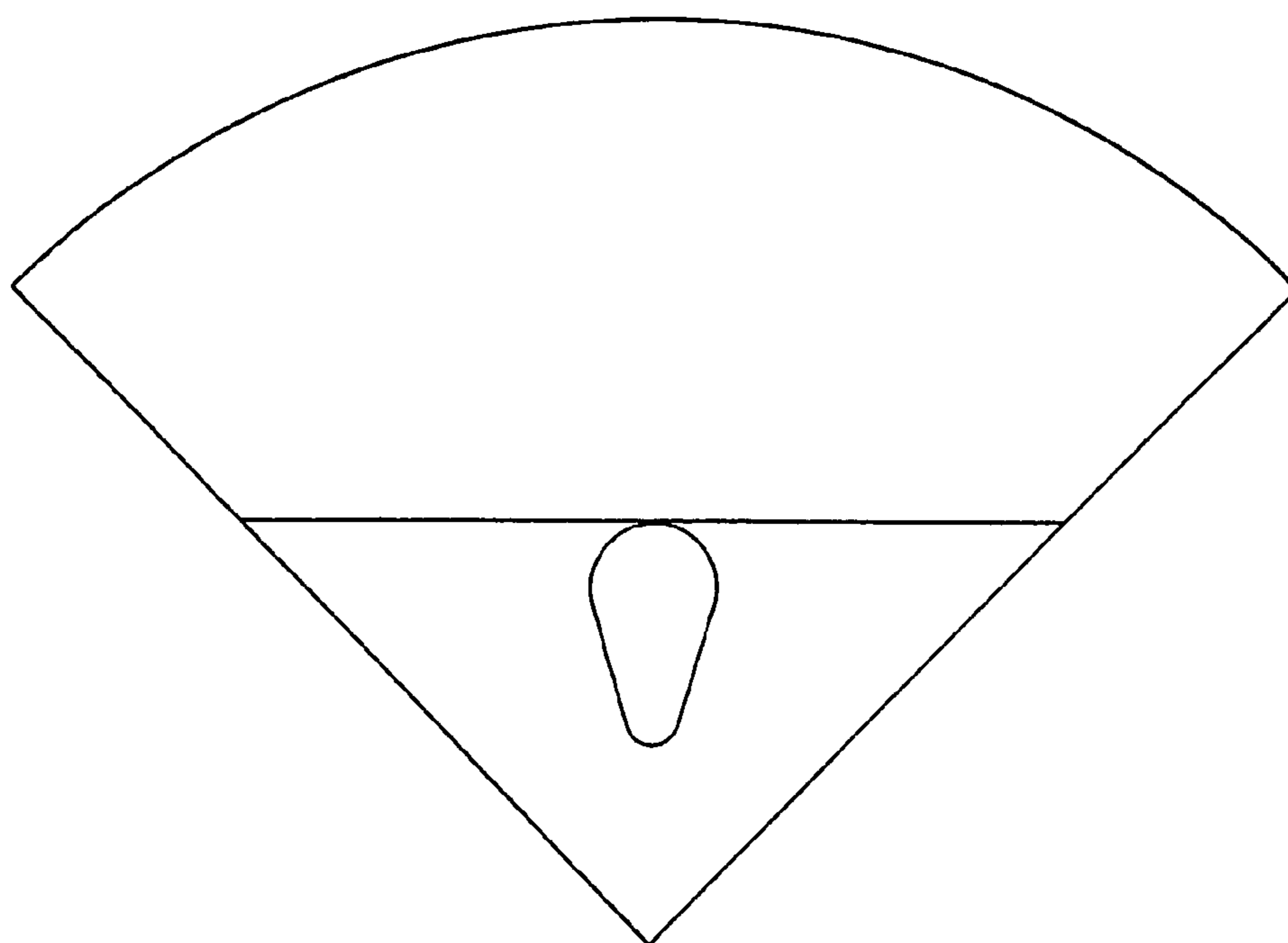

FIG. 6

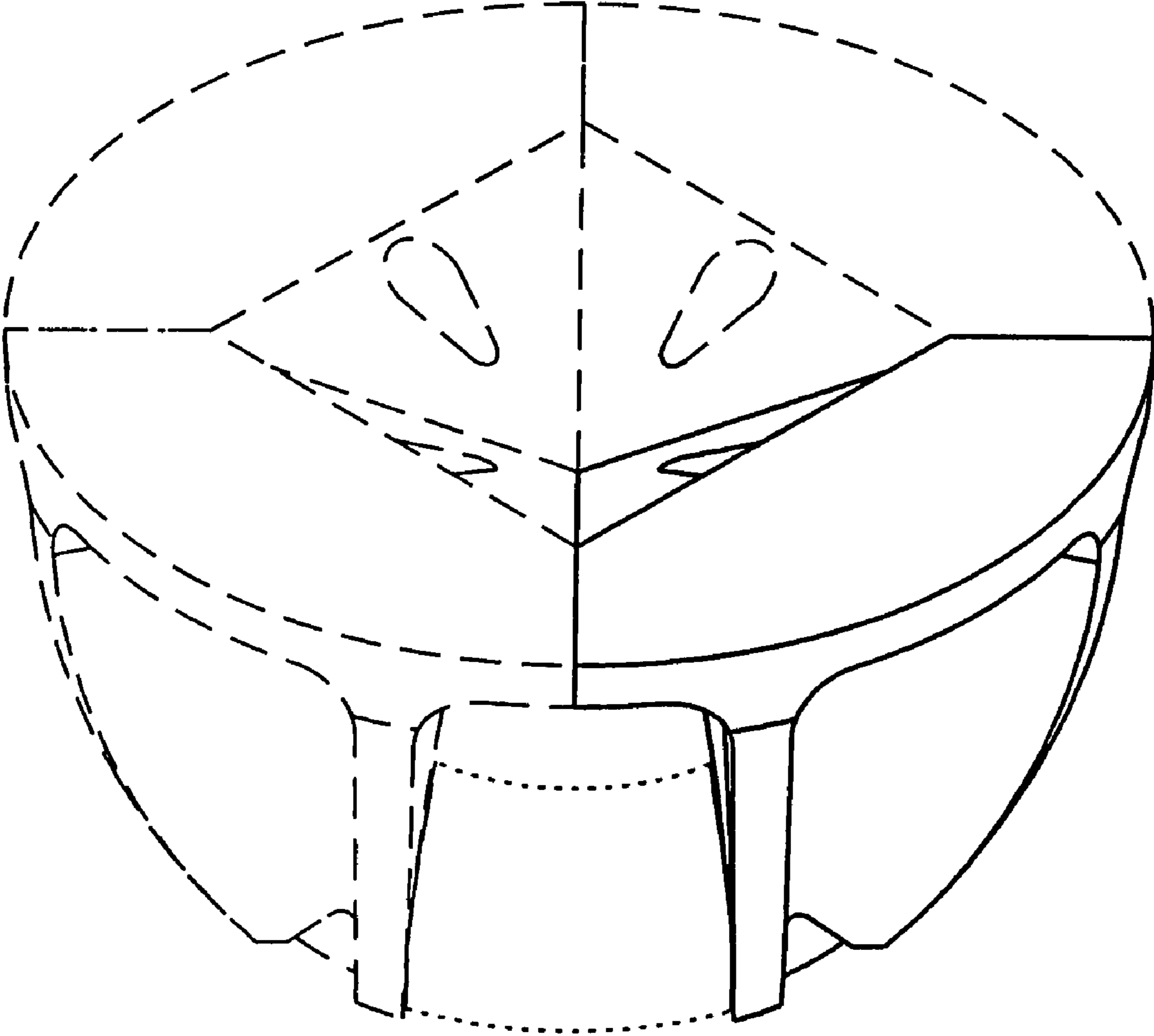

FIG. 7

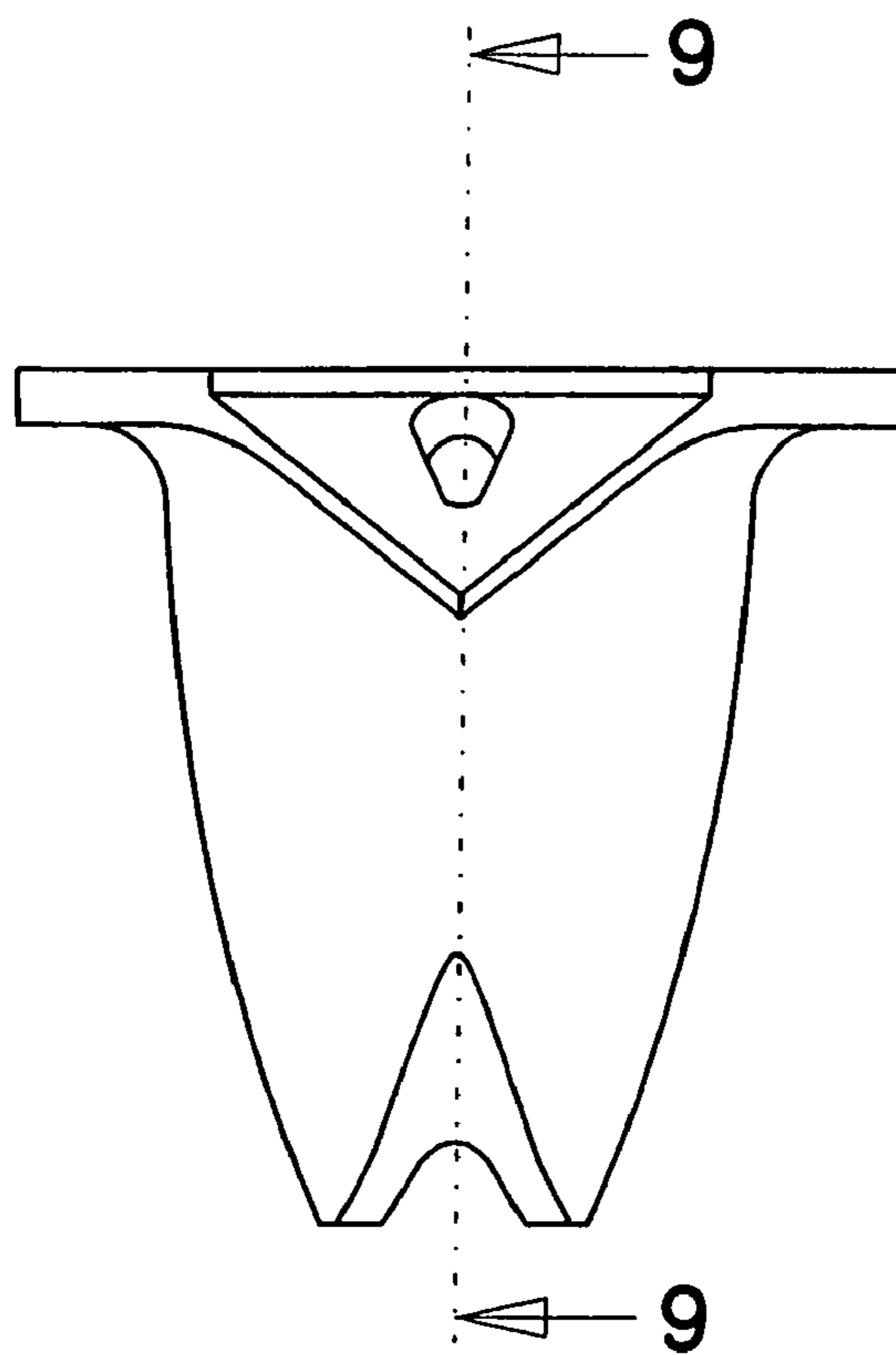

FIG. 8

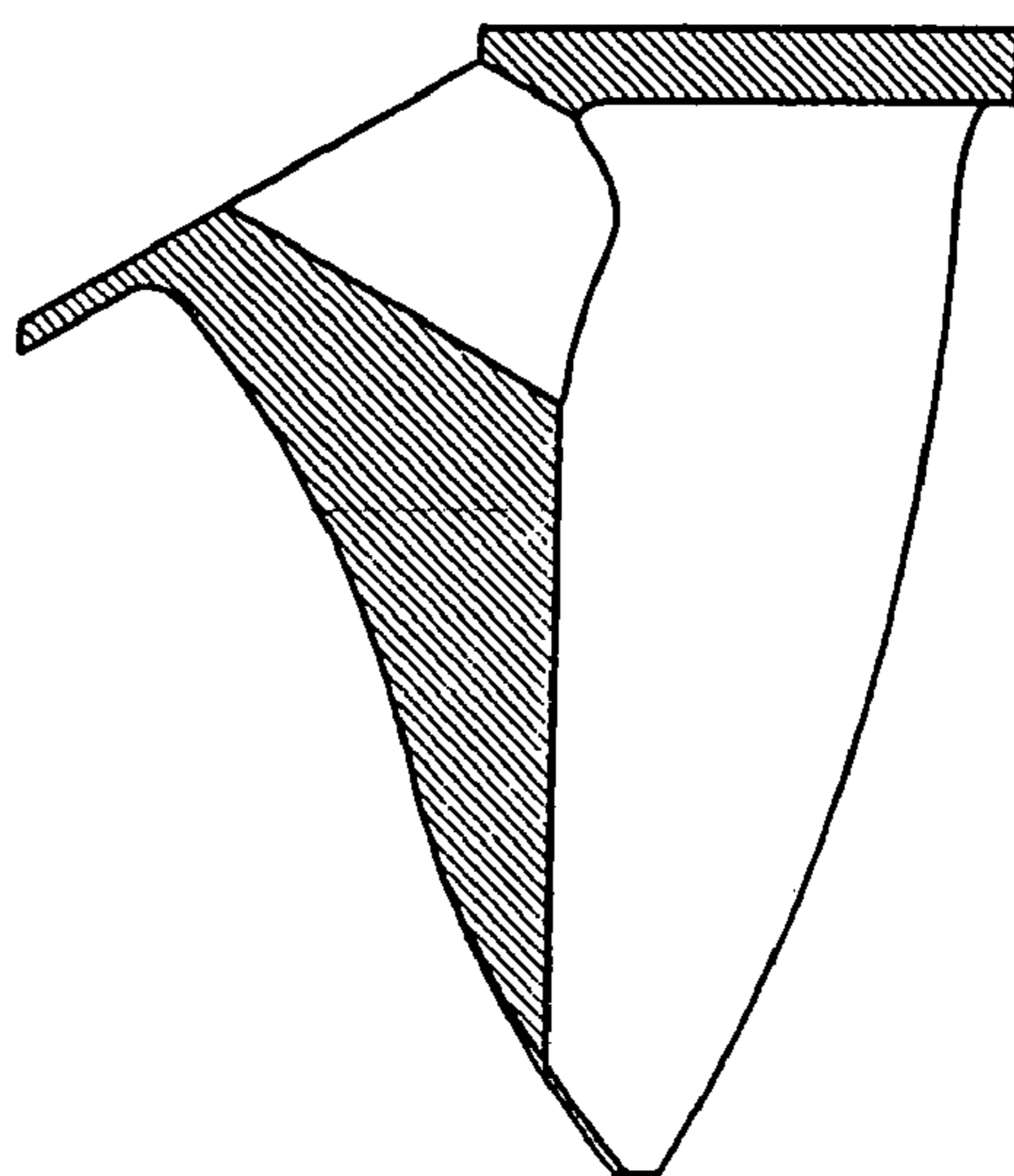

FIG. 9

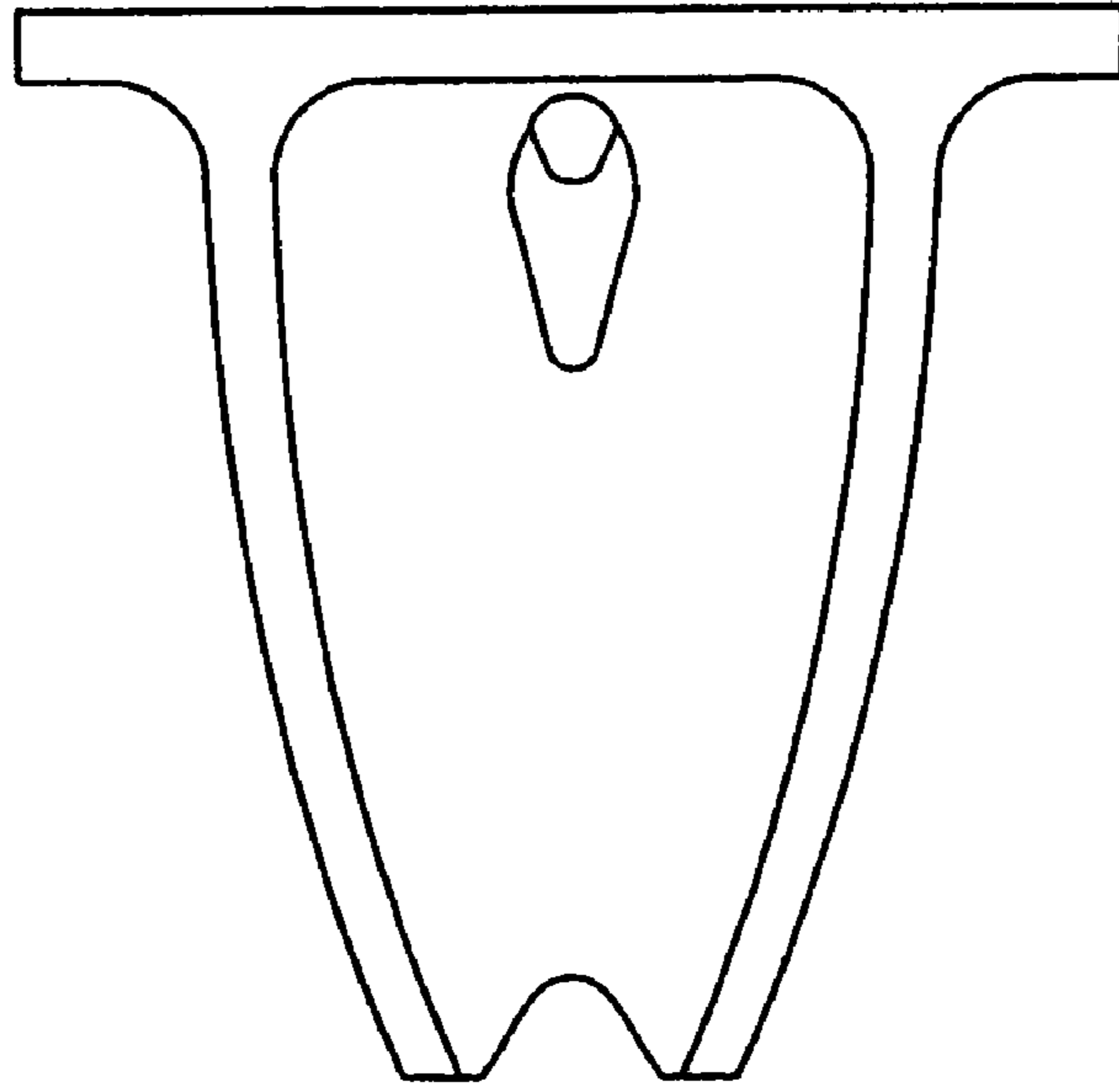

FIG. 10

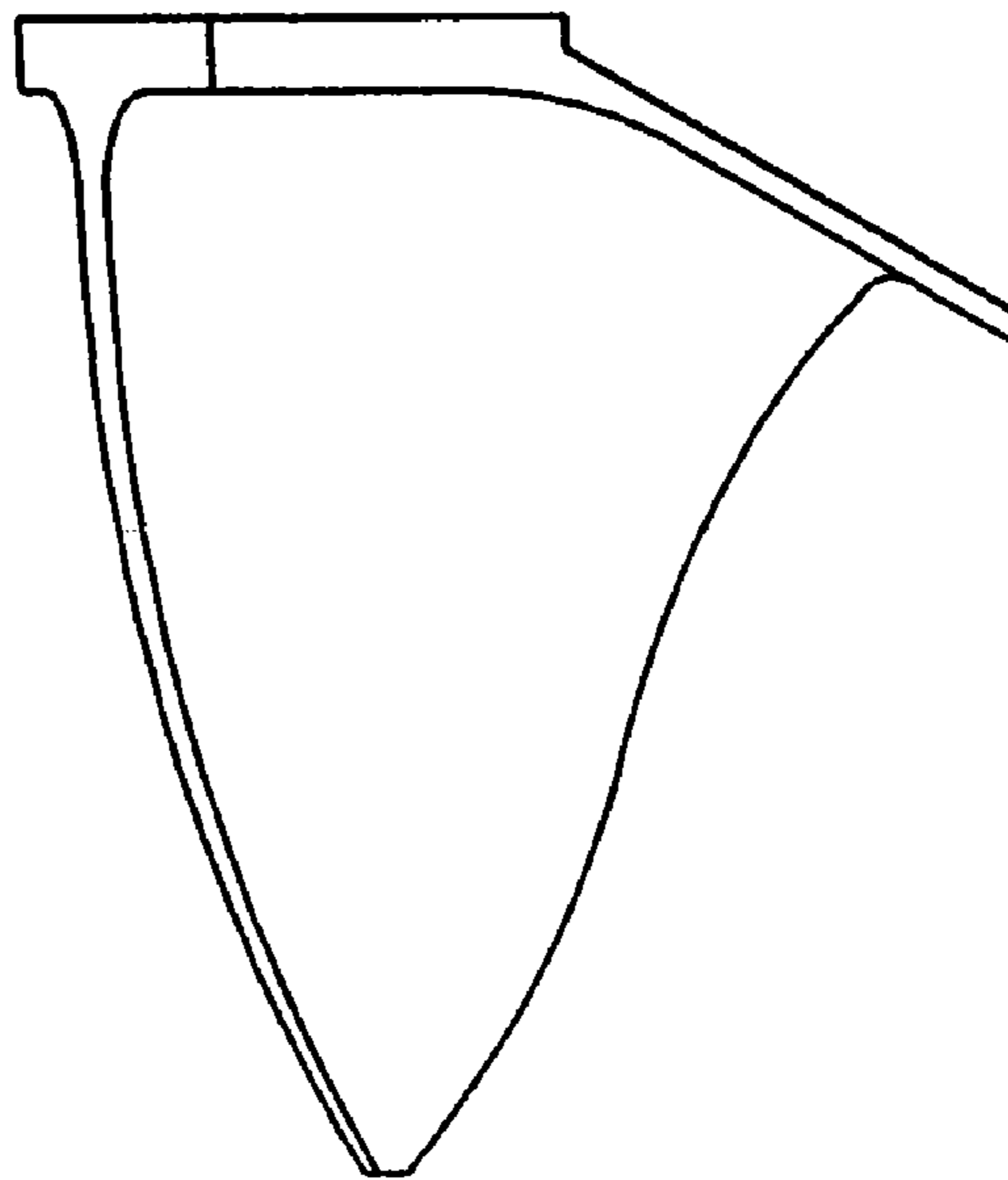

FIG. 11

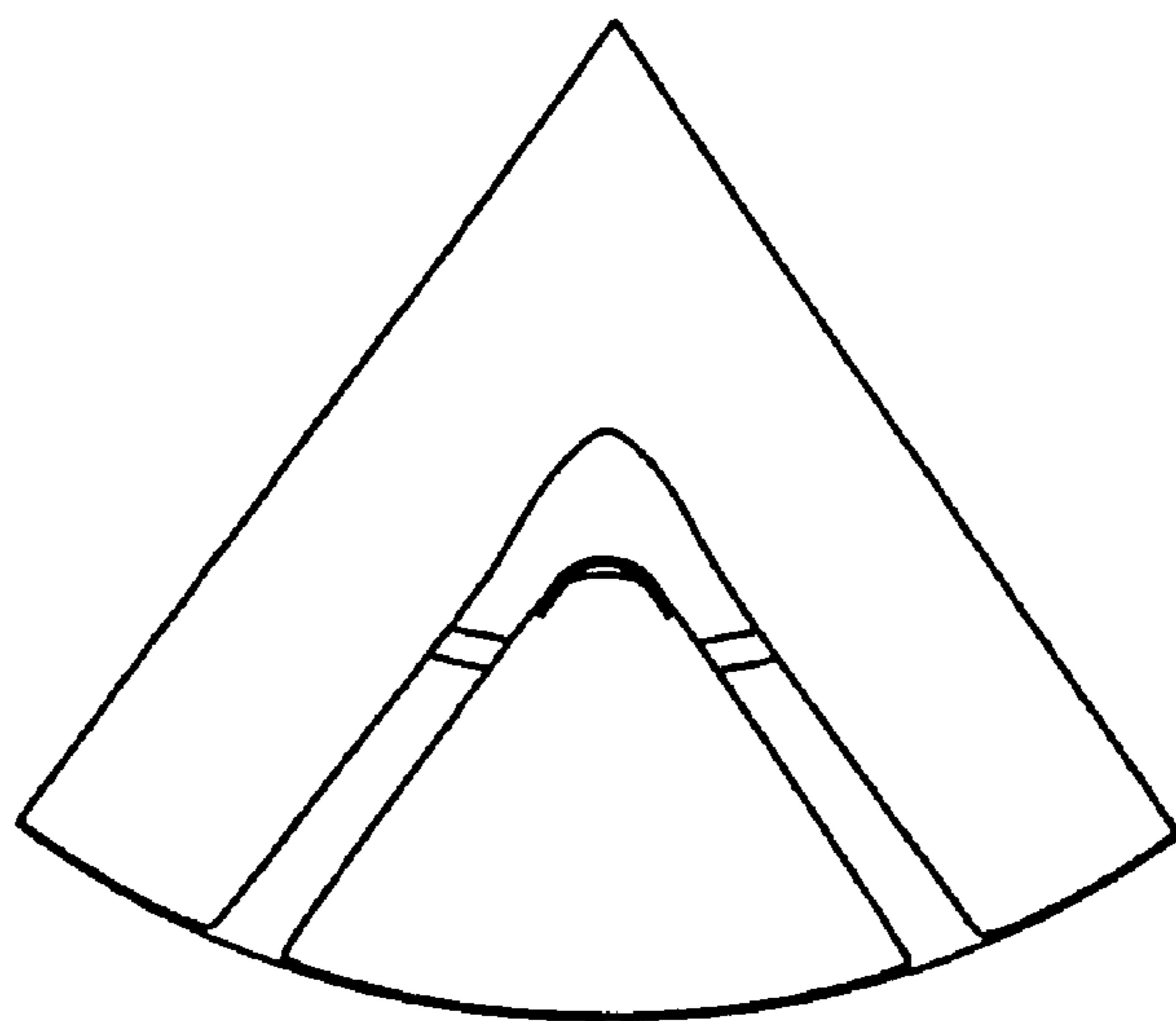

FIG. 12

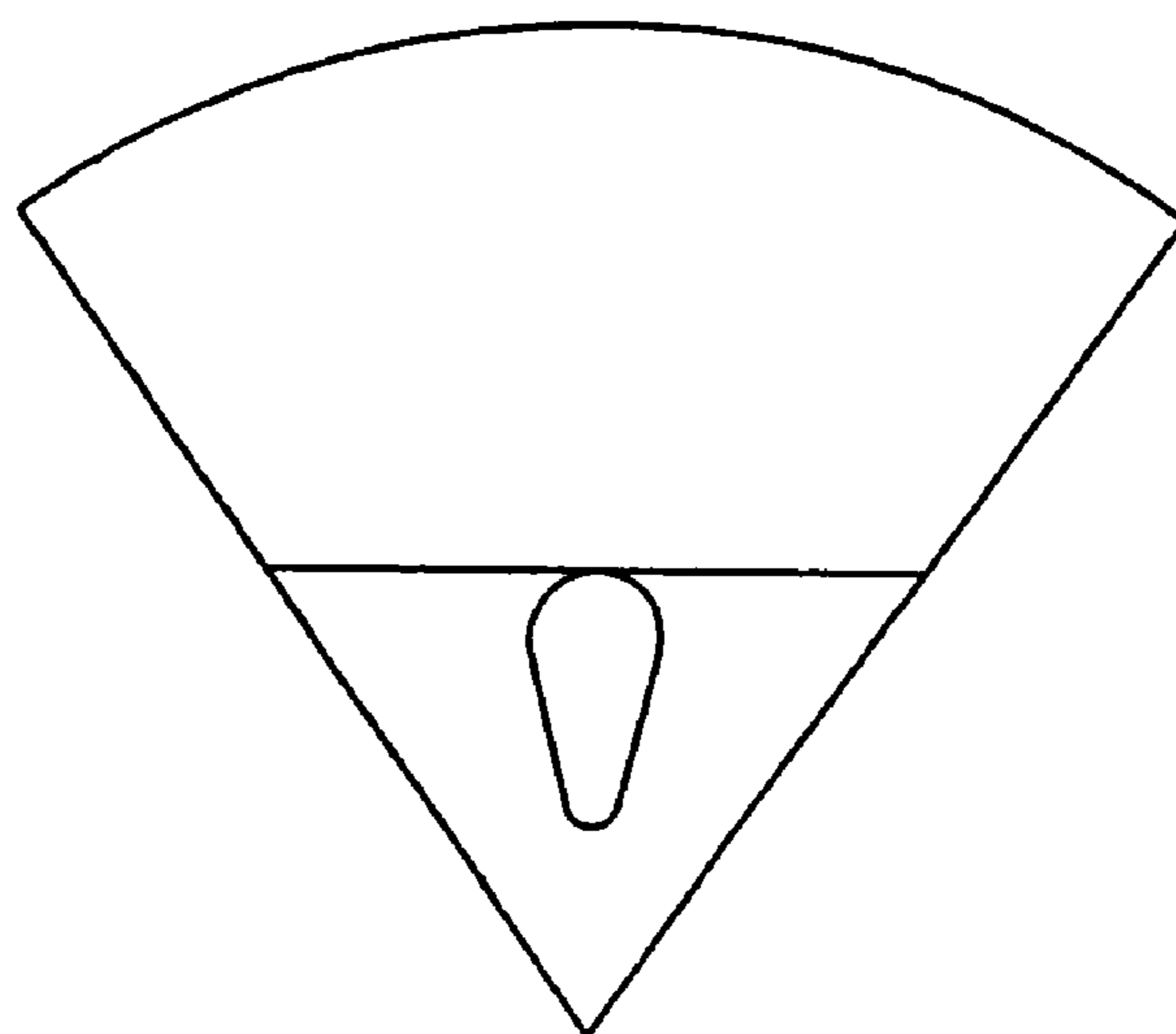

FIG. 13

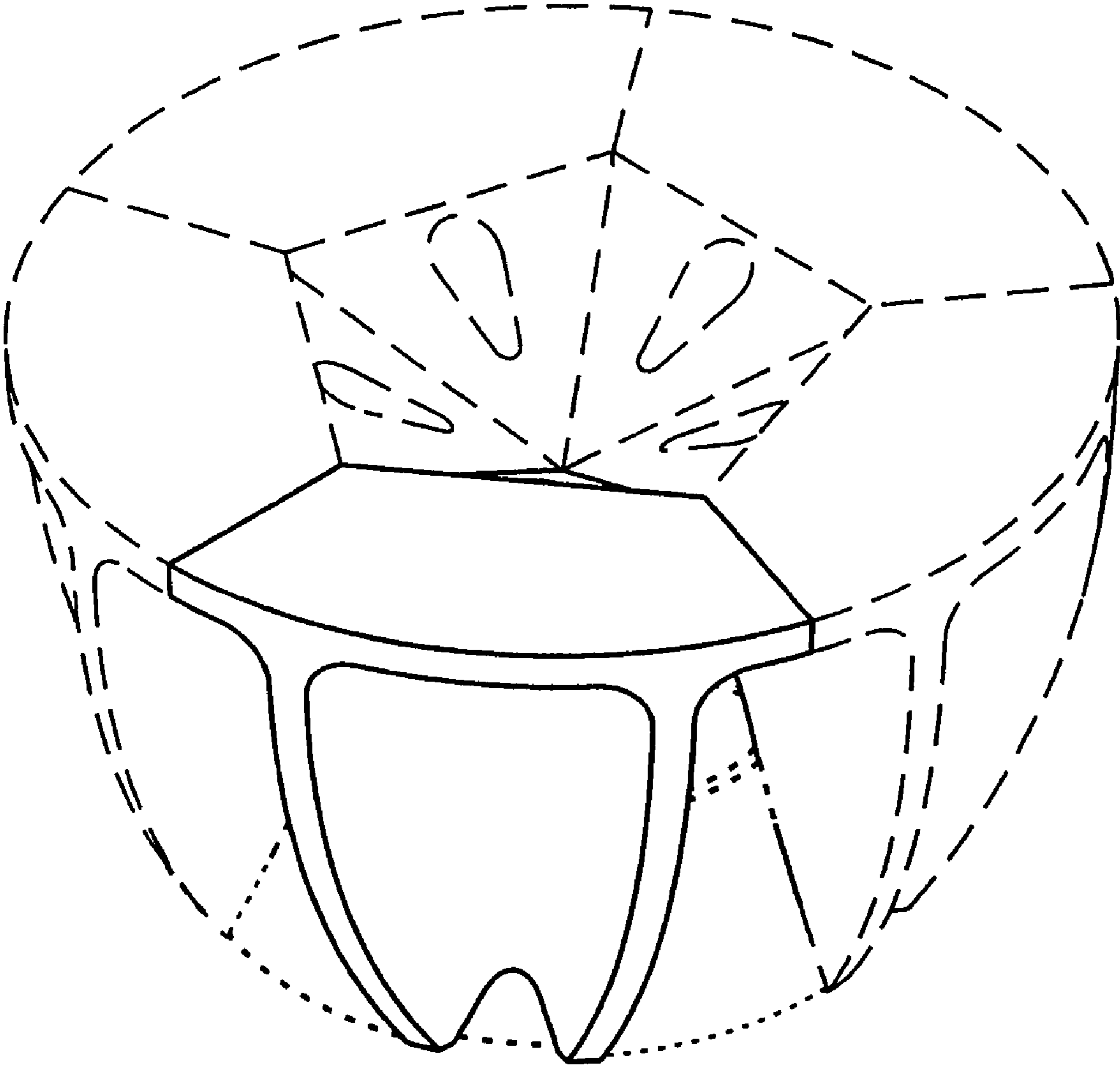

FIG. 14

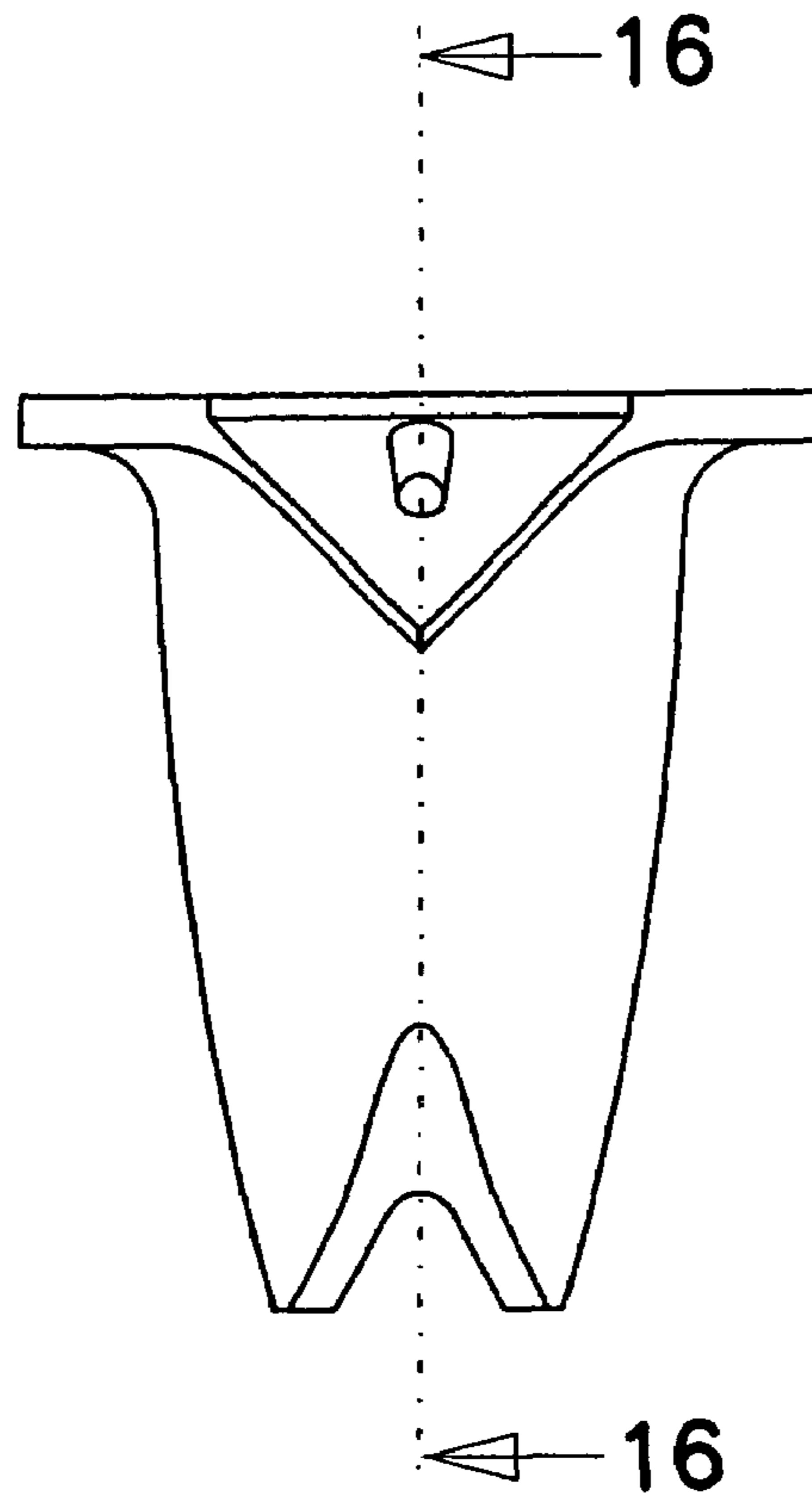

FIG. 15

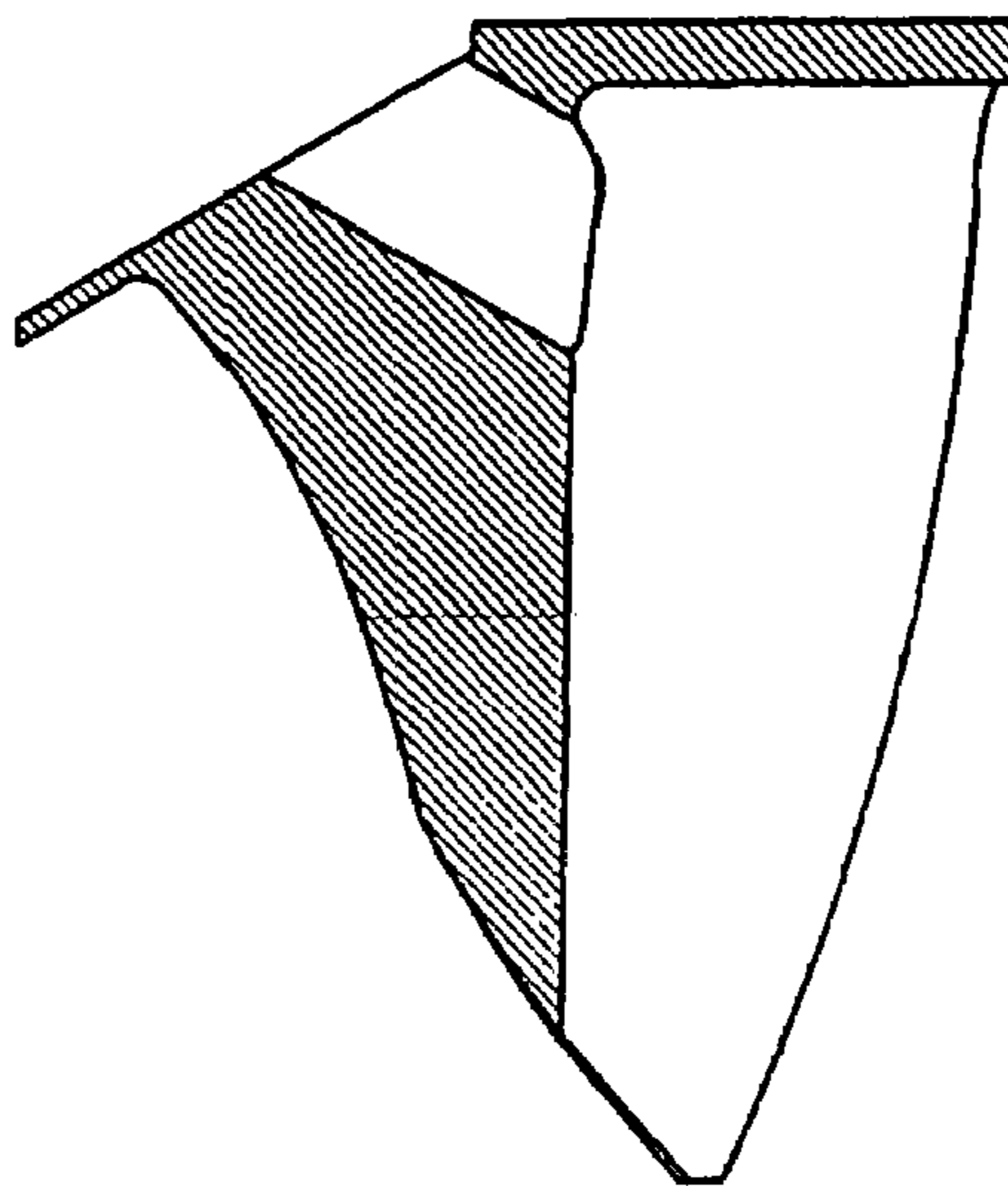

FIG. 16

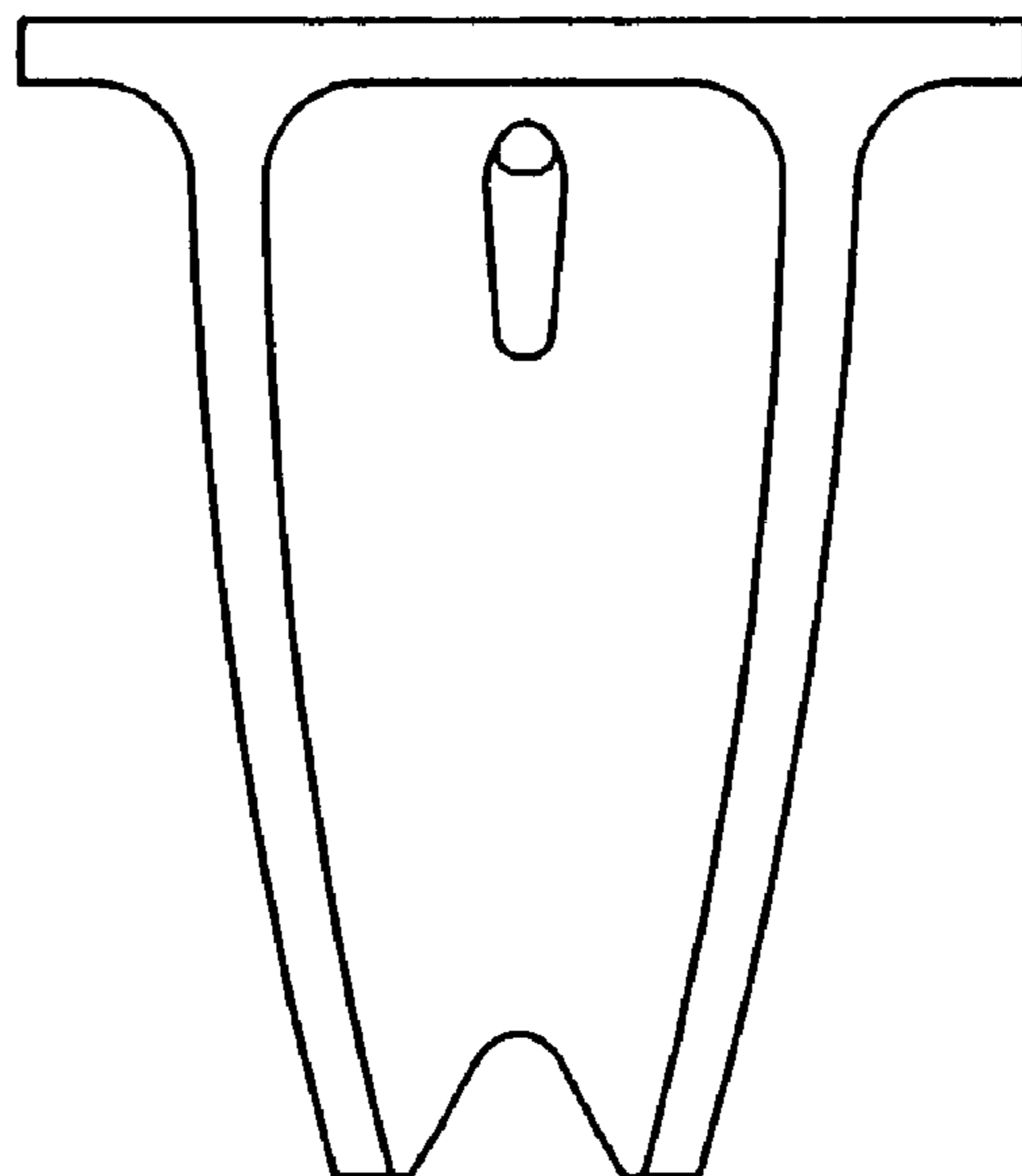

FIG. 17

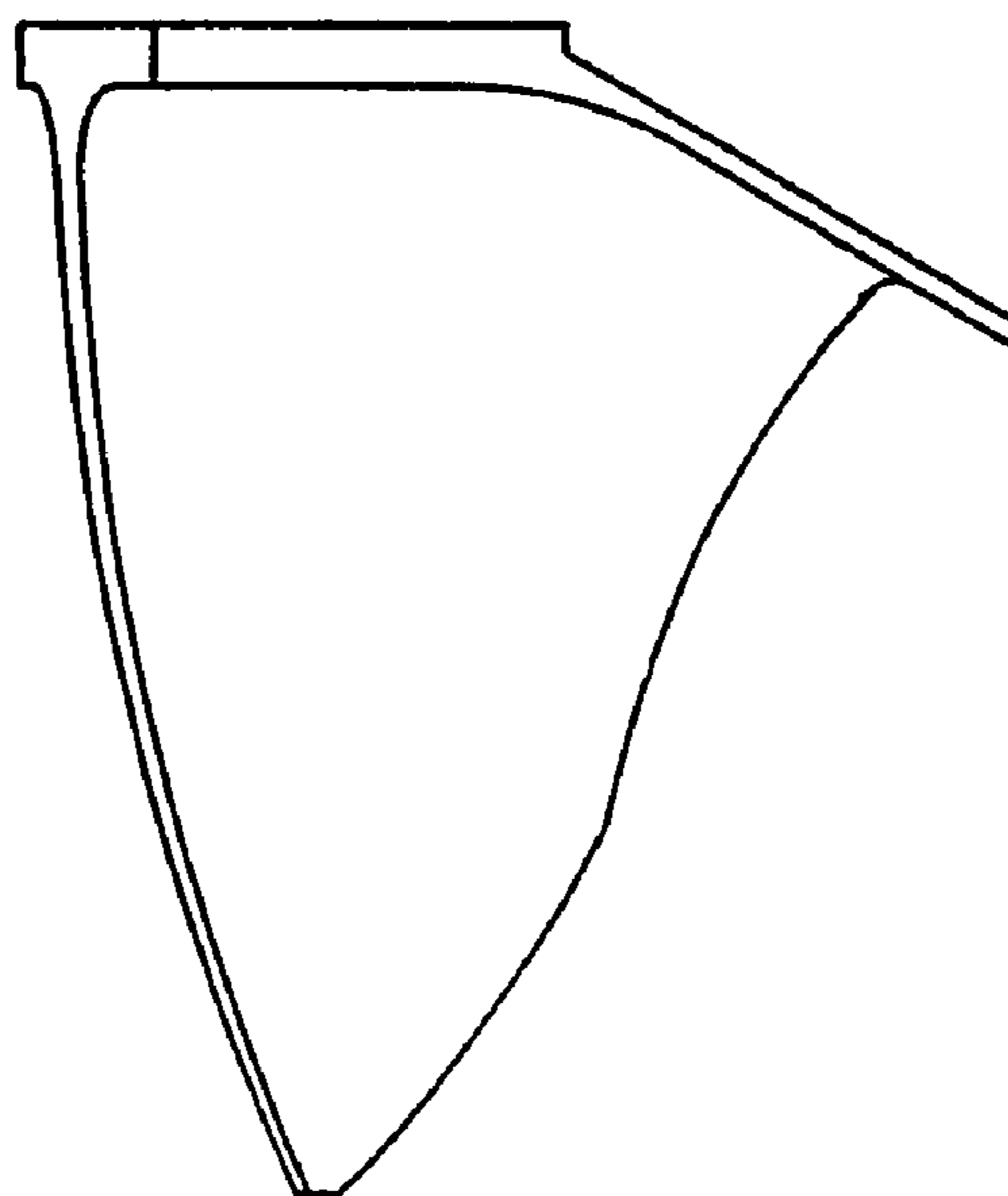

FIG. 18

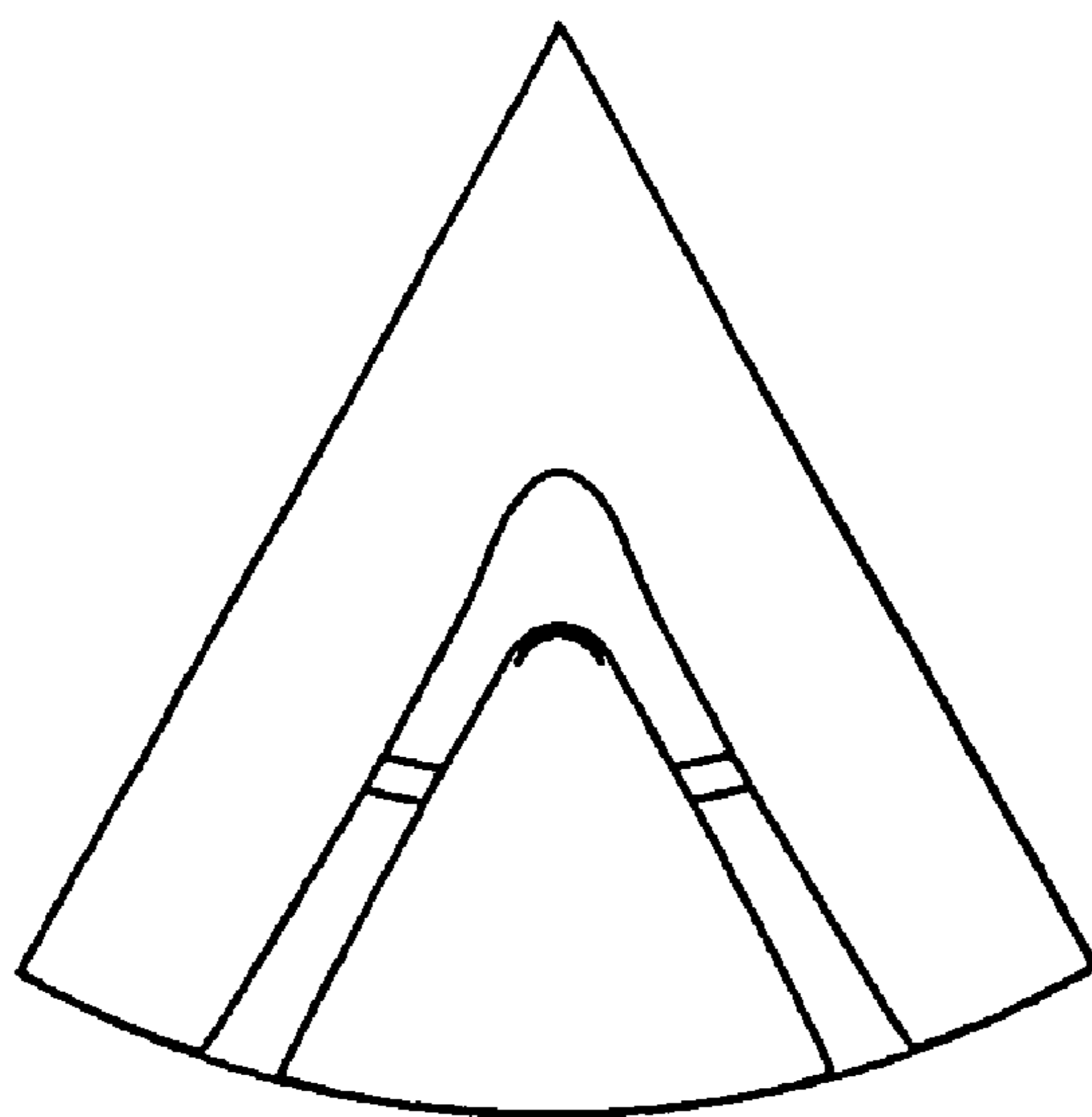

FIG. 19

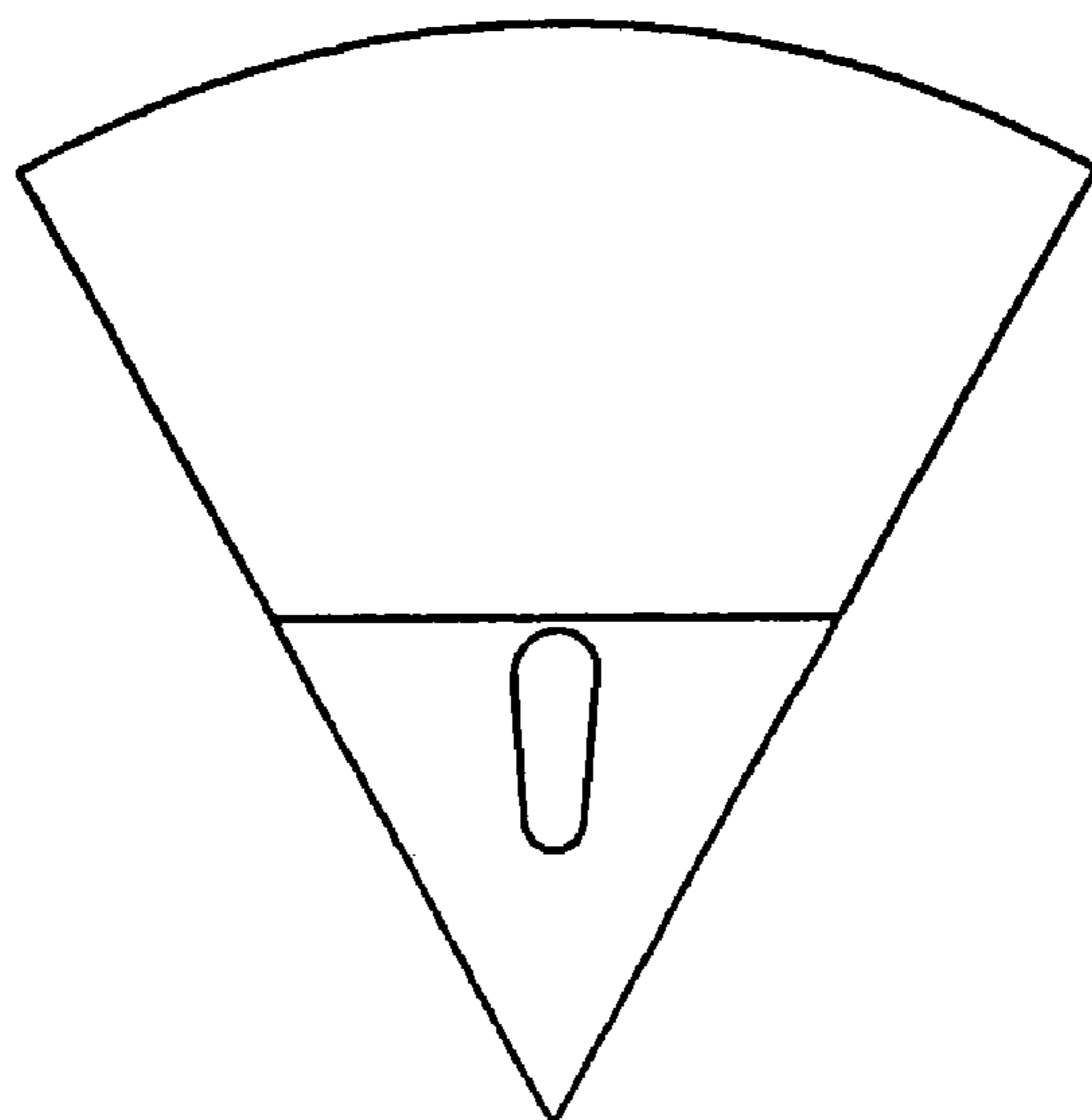

FIG. 20

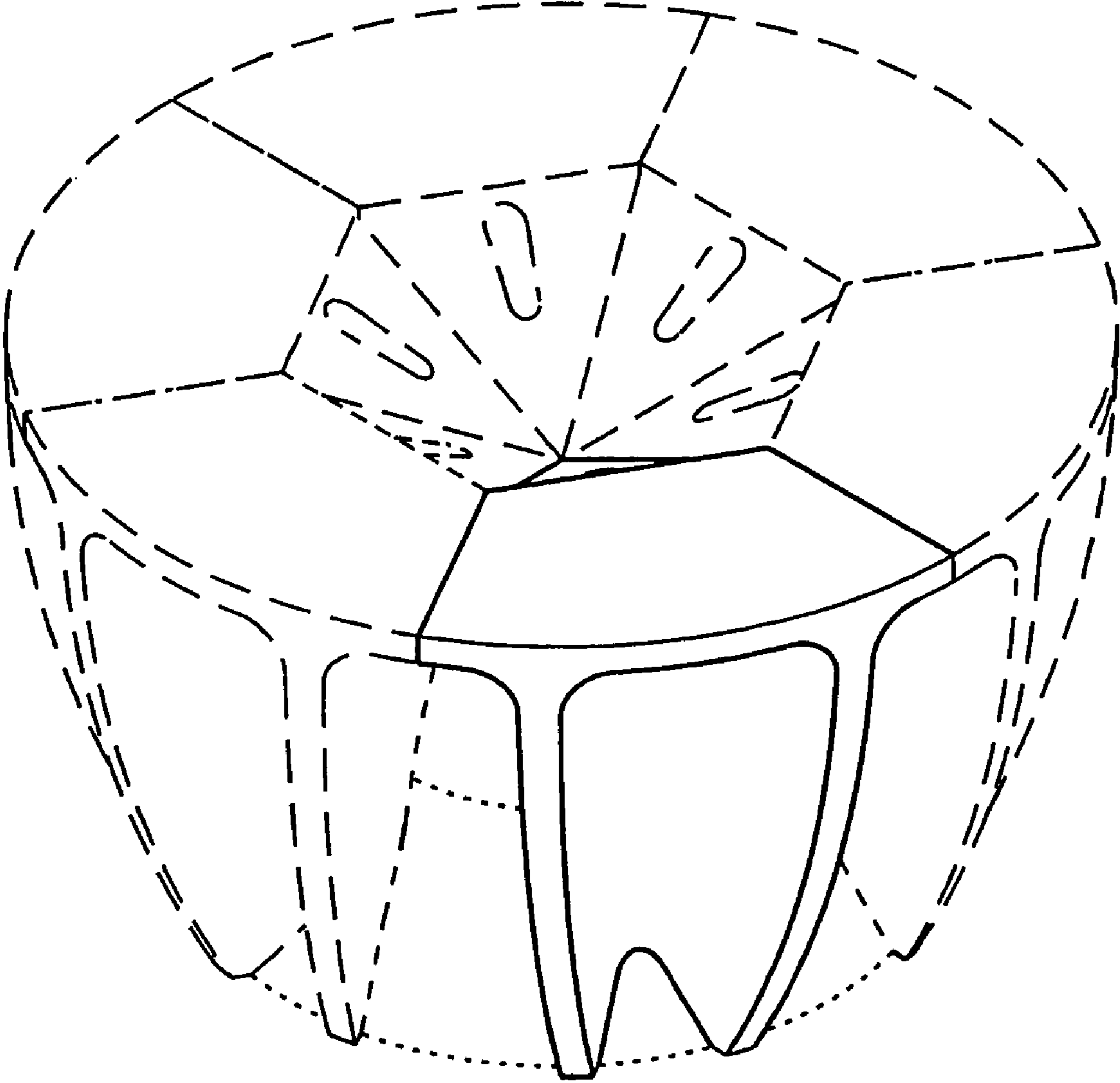

FIG. 21

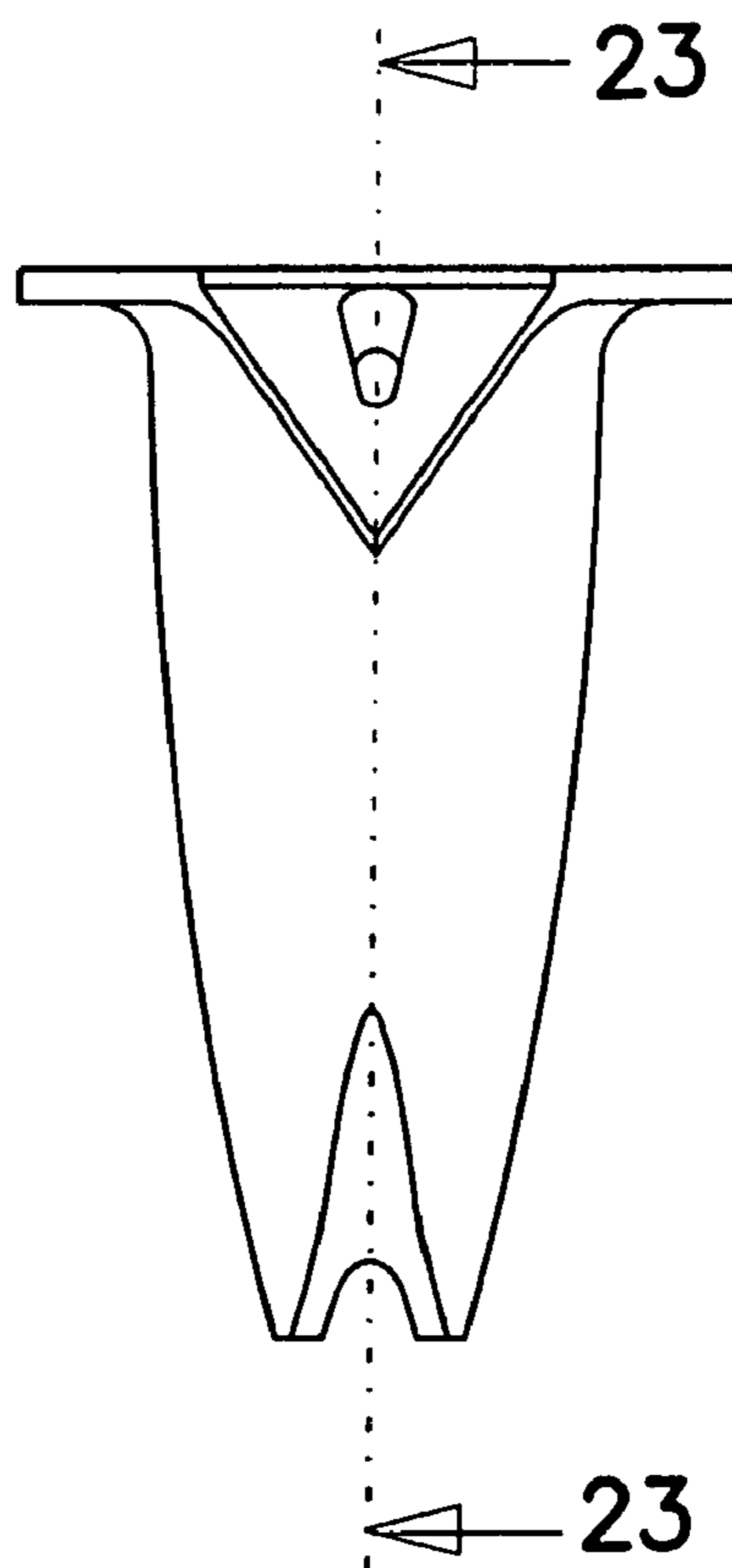

FIG. 22

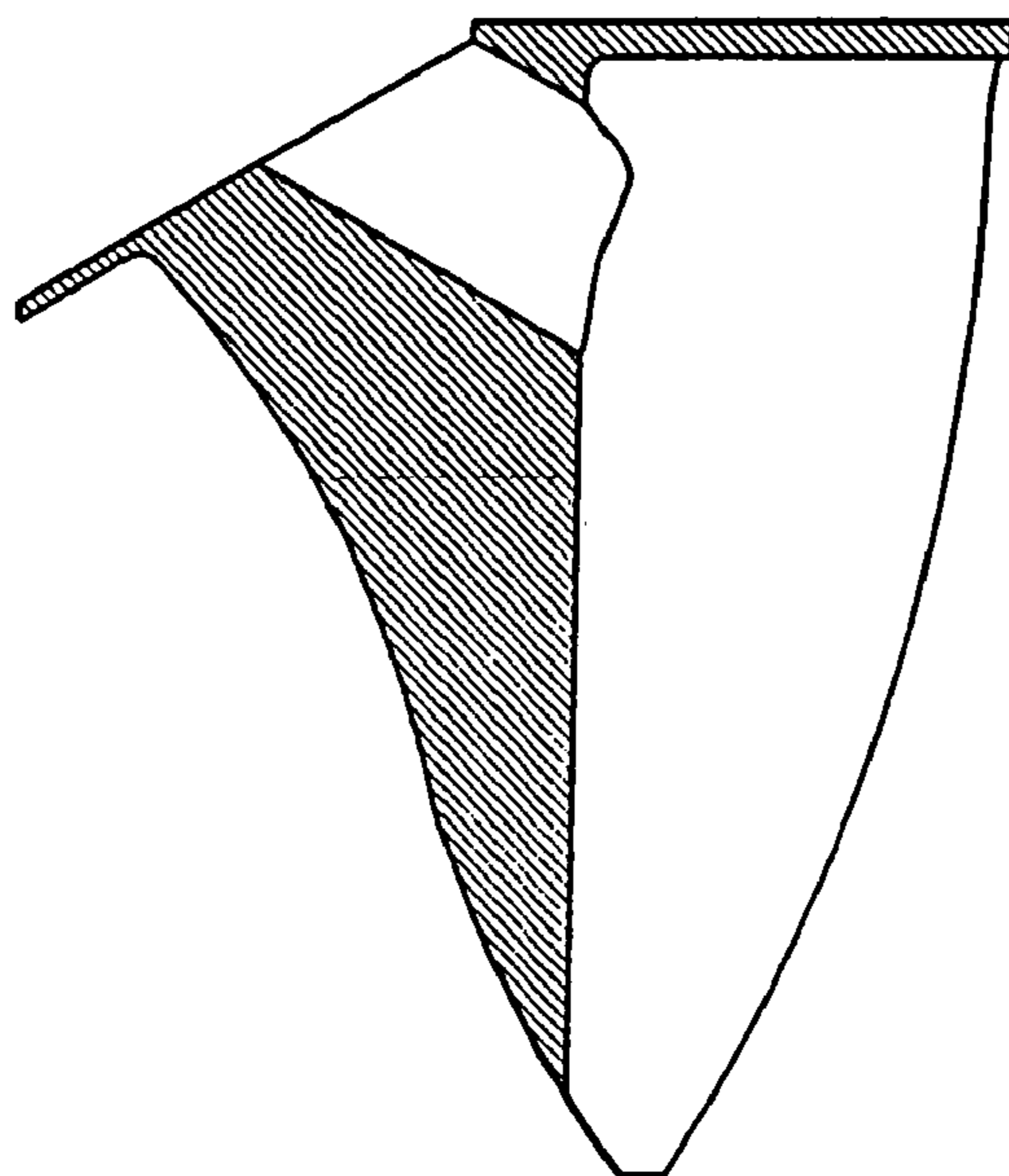

FIG. 23

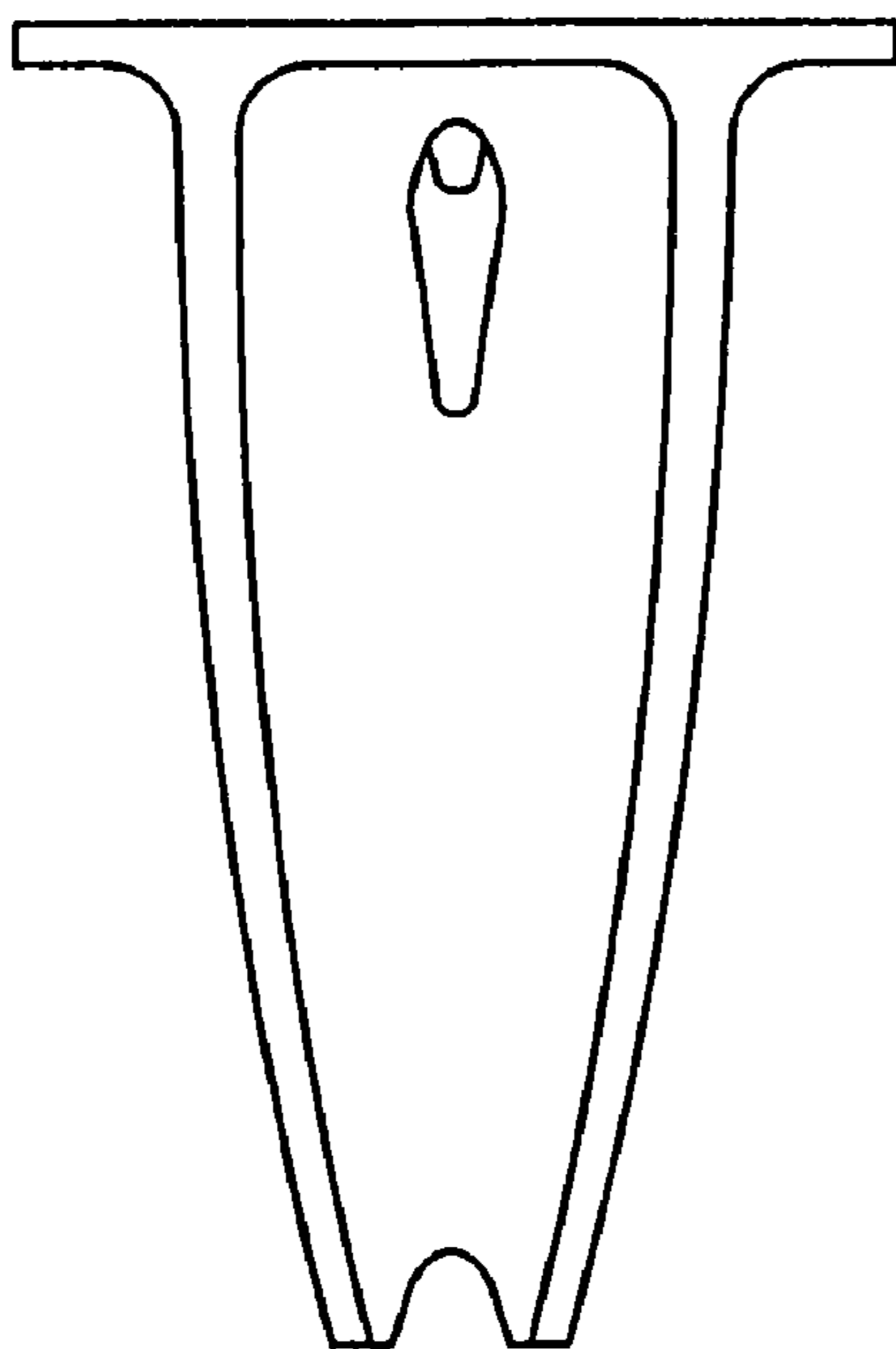

FIG. 24

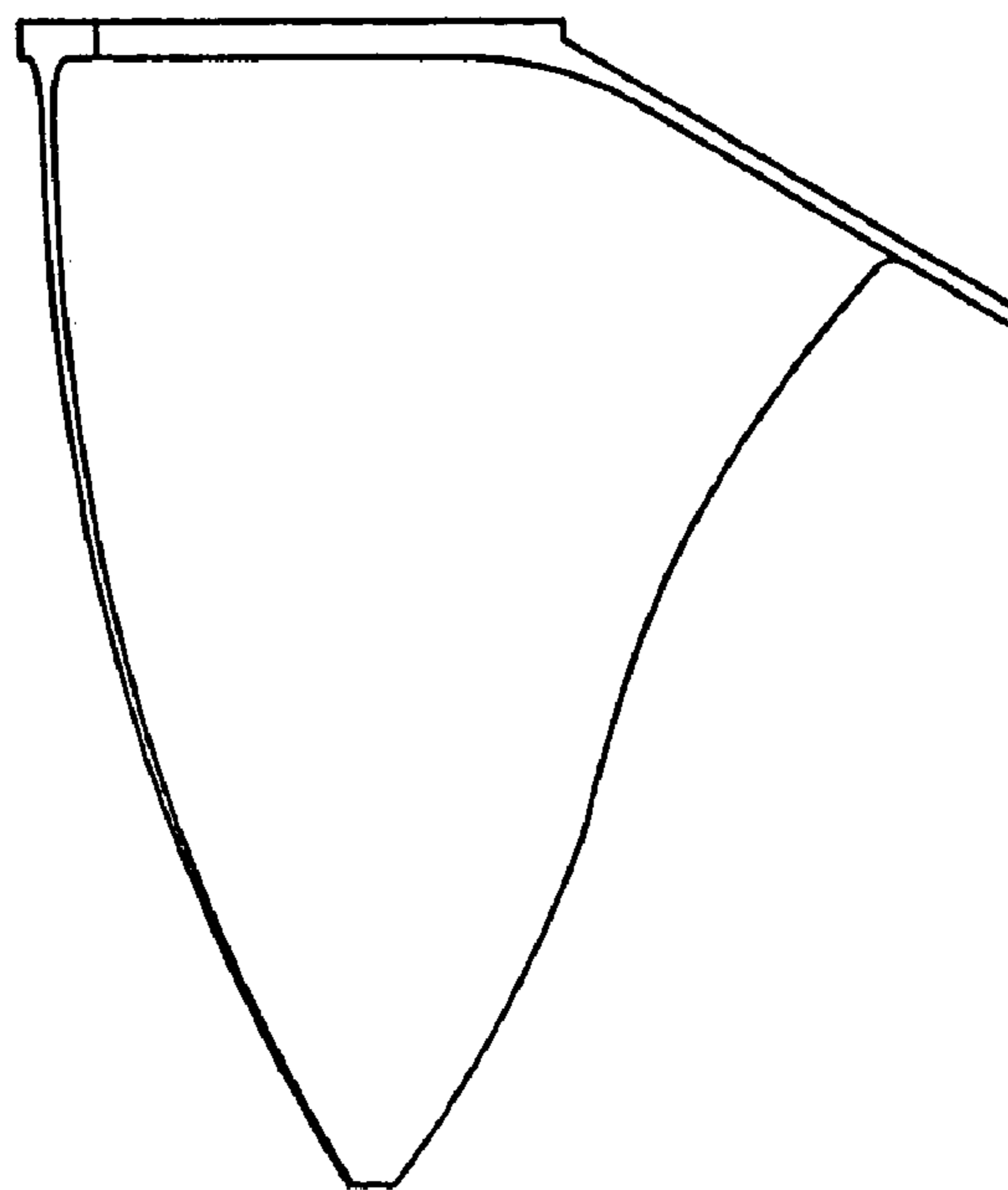

FIG. 25

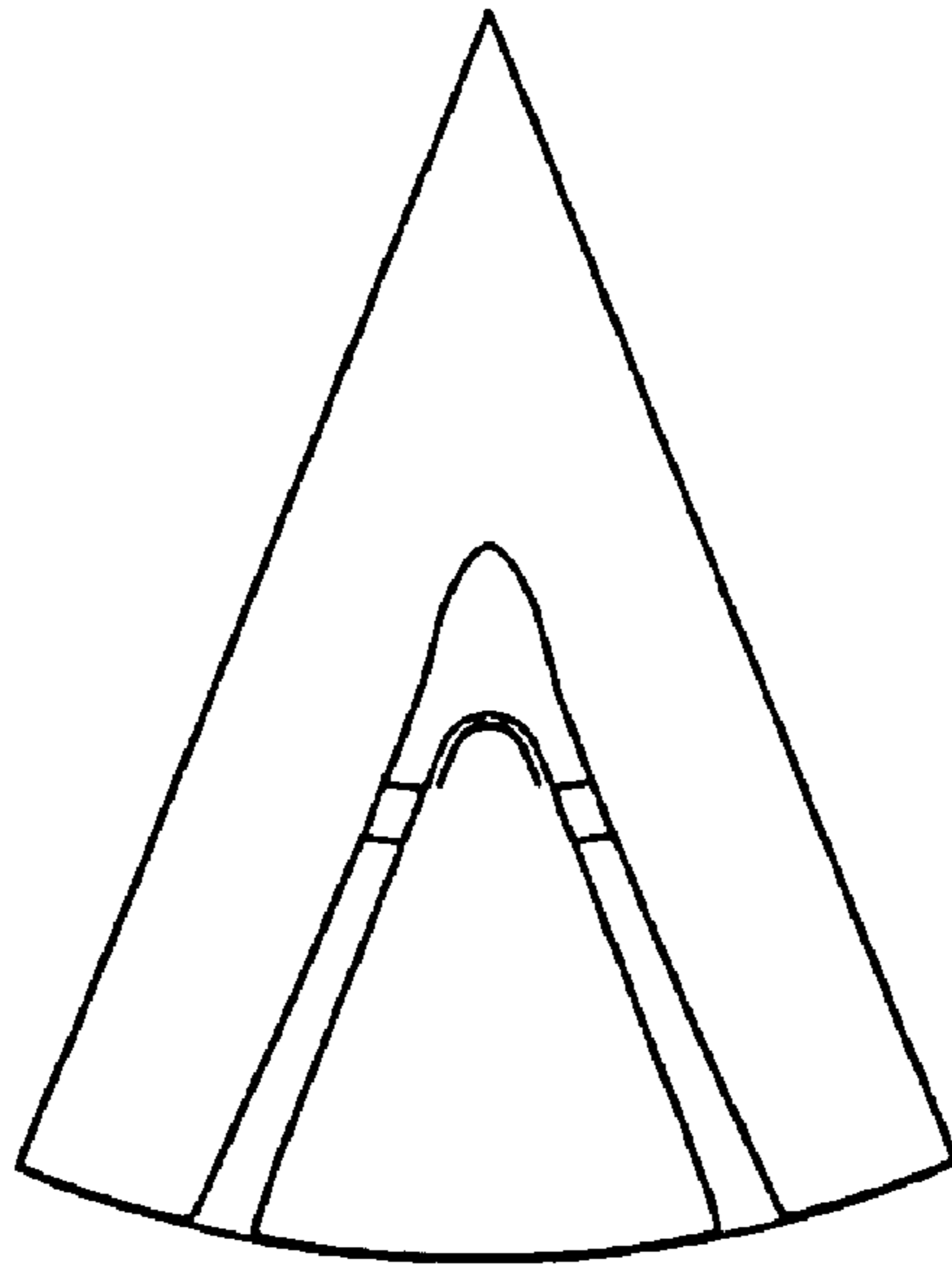

FIG. 26

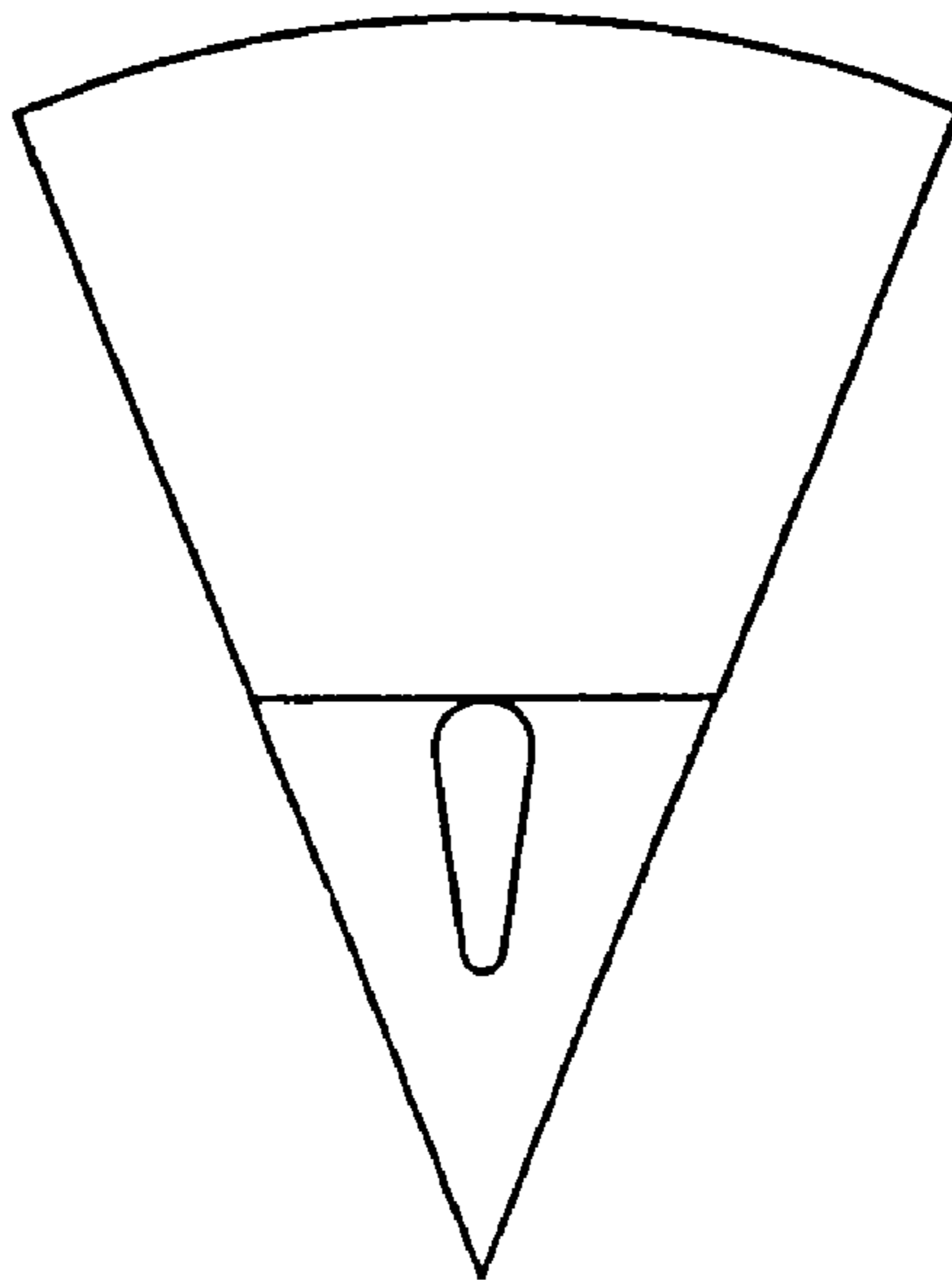

FIG. 27

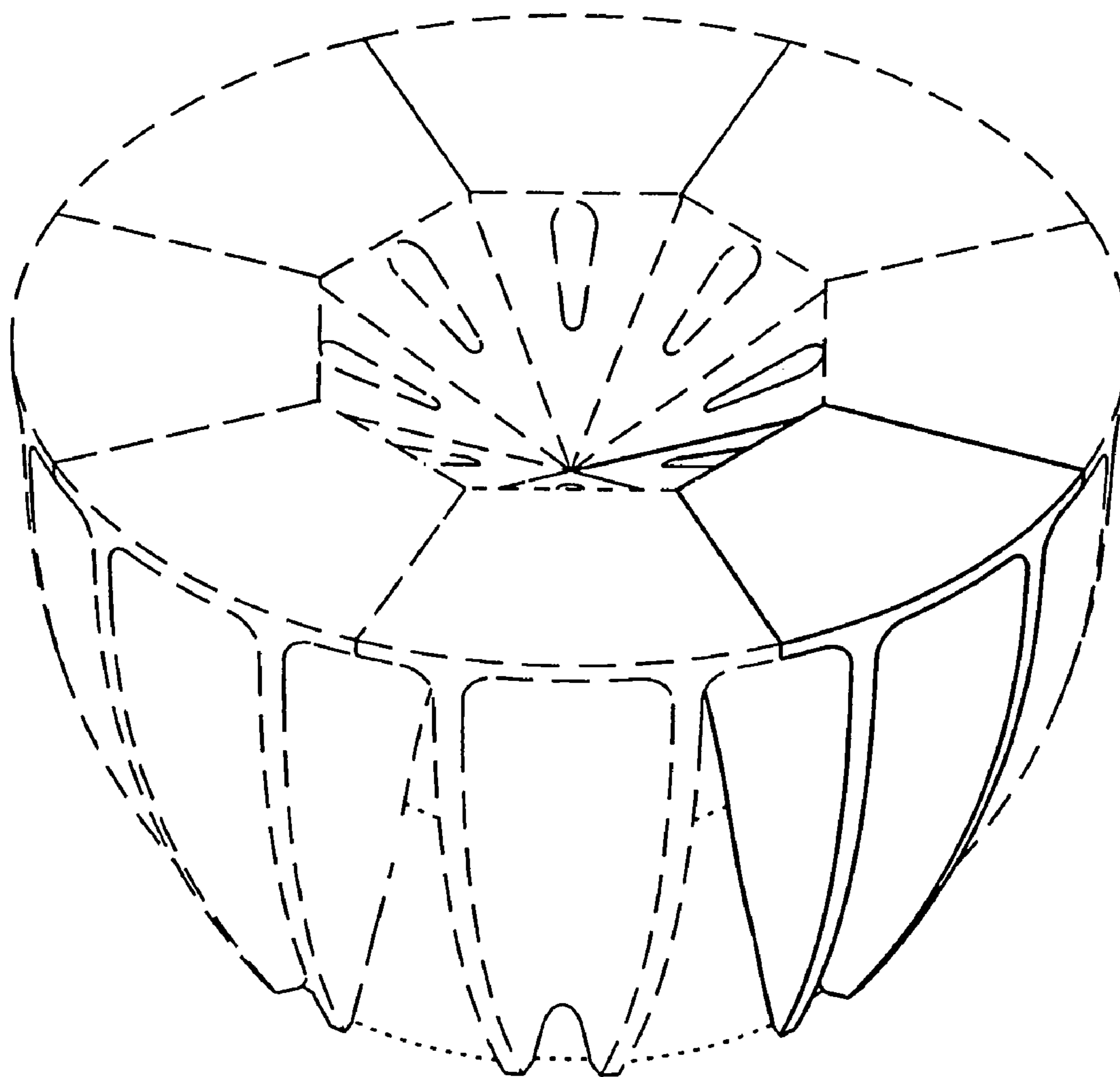

FIG. 28