

US00D605570S

(12) **United States Design Patent**
Schmitz et al.

(10) **Patent No.:** **US D605,570 S**

(45) **Date of Patent:** **** Dec. 8, 2009**

(54) **OUTER PORTION OF A BRAKE ROTOR**

(75) Inventors: **Johann Schmitz**, Wurmlingen (DE);
Ingo Hoffmann, Tuttlingen (DE)

(73) Assignee: **Schwabische Huttenwerke Automotive GmbH & Co. KG**

(**) Term: **14 Years**

(21) Appl. No.: **29/319,666**

(22) Filed: **Jun. 12, 2008**

(30) **Foreign Application Priority Data**

Dec. 12, 2007 (DE) 407 06 127

(51) **LOC (9) Cl.** **12-16**

(52) **U.S. Cl.** **D12/180**

(58) **Field of Classification Search** D12/179-180;
188/218 XL, 264 R, 26, 73, 1, 24.22, 73.31-73.43
See application file for complete search history.

(56) **References Cited**

U.S. PATENT DOCUMENTS

D458,882 S * 6/2002 Oberti D12/180

D465,179 S * 11/2002 Ballinger D12/180
D482,643 S * 11/2003 Gavin D12/180
D484,836 S * 1/2004 Gavin D12/180
7,159,698 B2 * 1/2007 Banks et al. 188/218 XL
D565,487 S 4/2008 Zhang
2006/0086579 A1 * 4/2006 Gerber 188/218 XL
2006/0124410 A1 * 6/2006 Drage 188/218 XL
2007/0199778 A1 * 8/2007 Lee 188/218 XL
2008/0135359 A1 * 6/2008 Basirico et al. 188/218 XL
2009/0000884 A1 * 1/2009 Layton et al. 188/218 XL
2009/0020379 A1 * 1/2009 Hanna et al. 188/218 XL

* cited by examiner

Primary Examiner—Antoine D Davis

(74) *Attorney, Agent, or Firm*—Gray Robinson, PA

(57) **CLAIM**

The ornamental design of an outer portion of a brake rotor, as shown and described.

DESCRIPTION

FIG. 1 is a front elevational view of a first embodiment thereof; and,

FIG. 2 is a partial perspective view of the embodiment of FIG. 1.

1 Claim, 1 Drawing Sheet

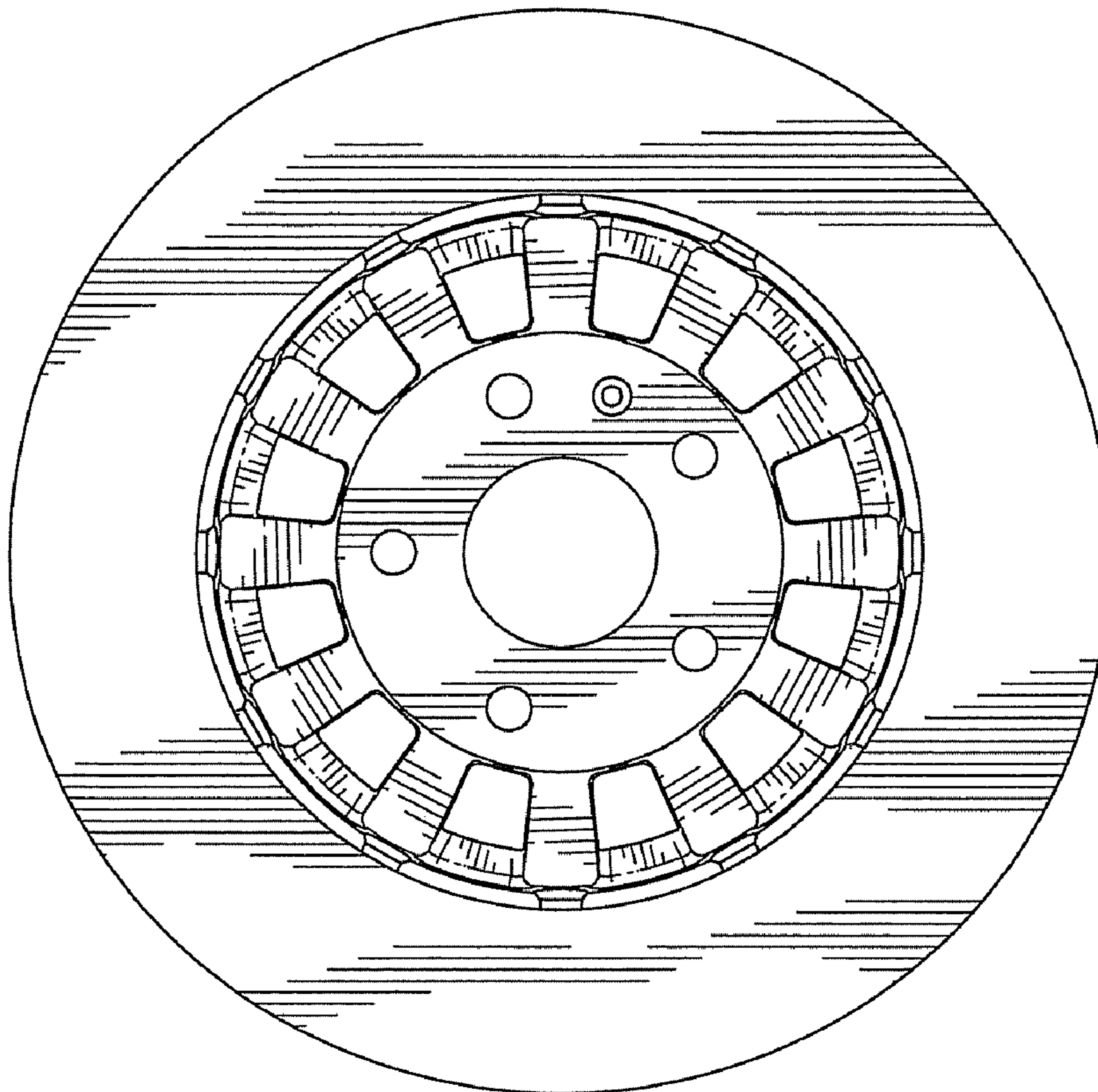

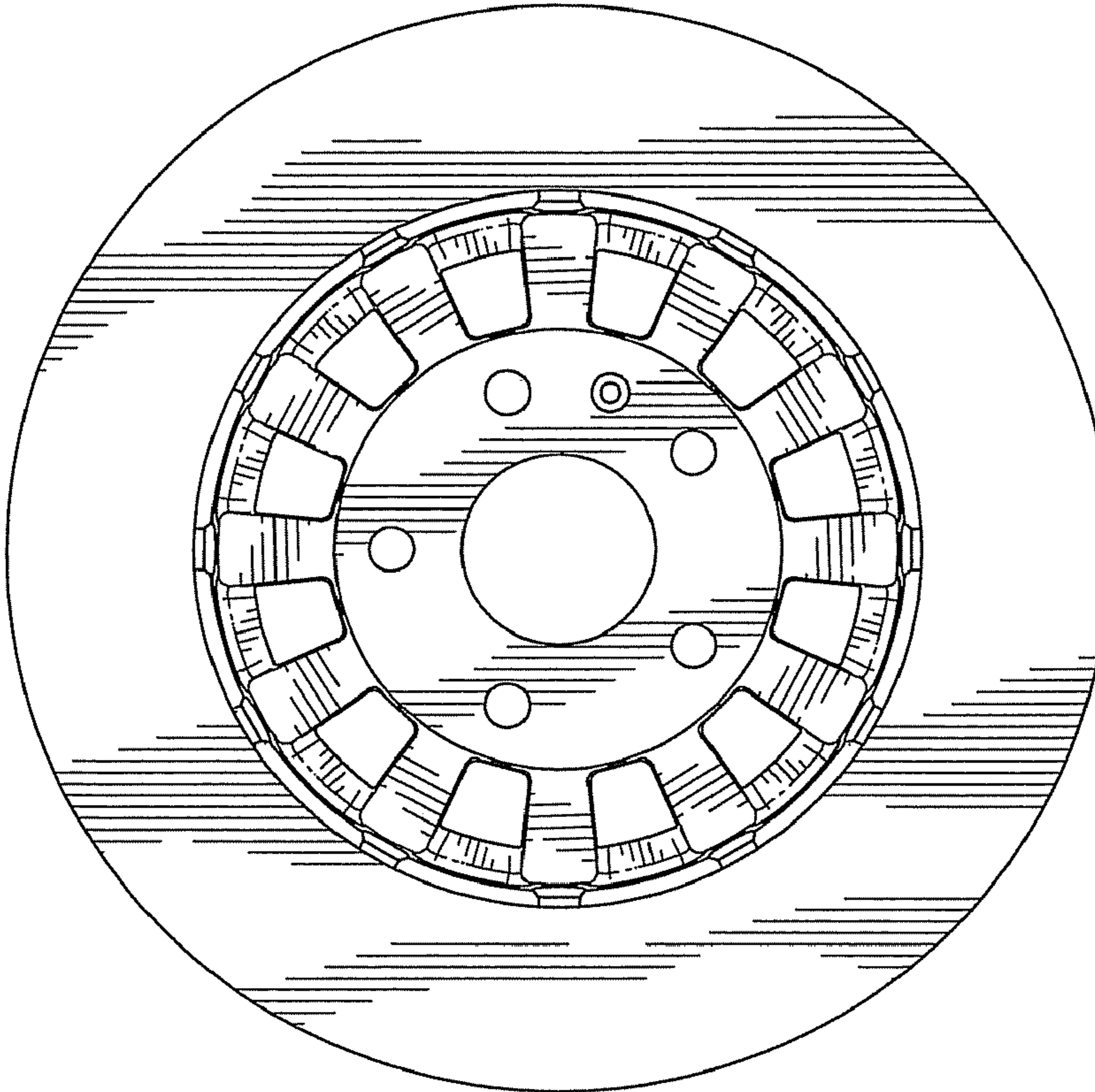

FIG. 1

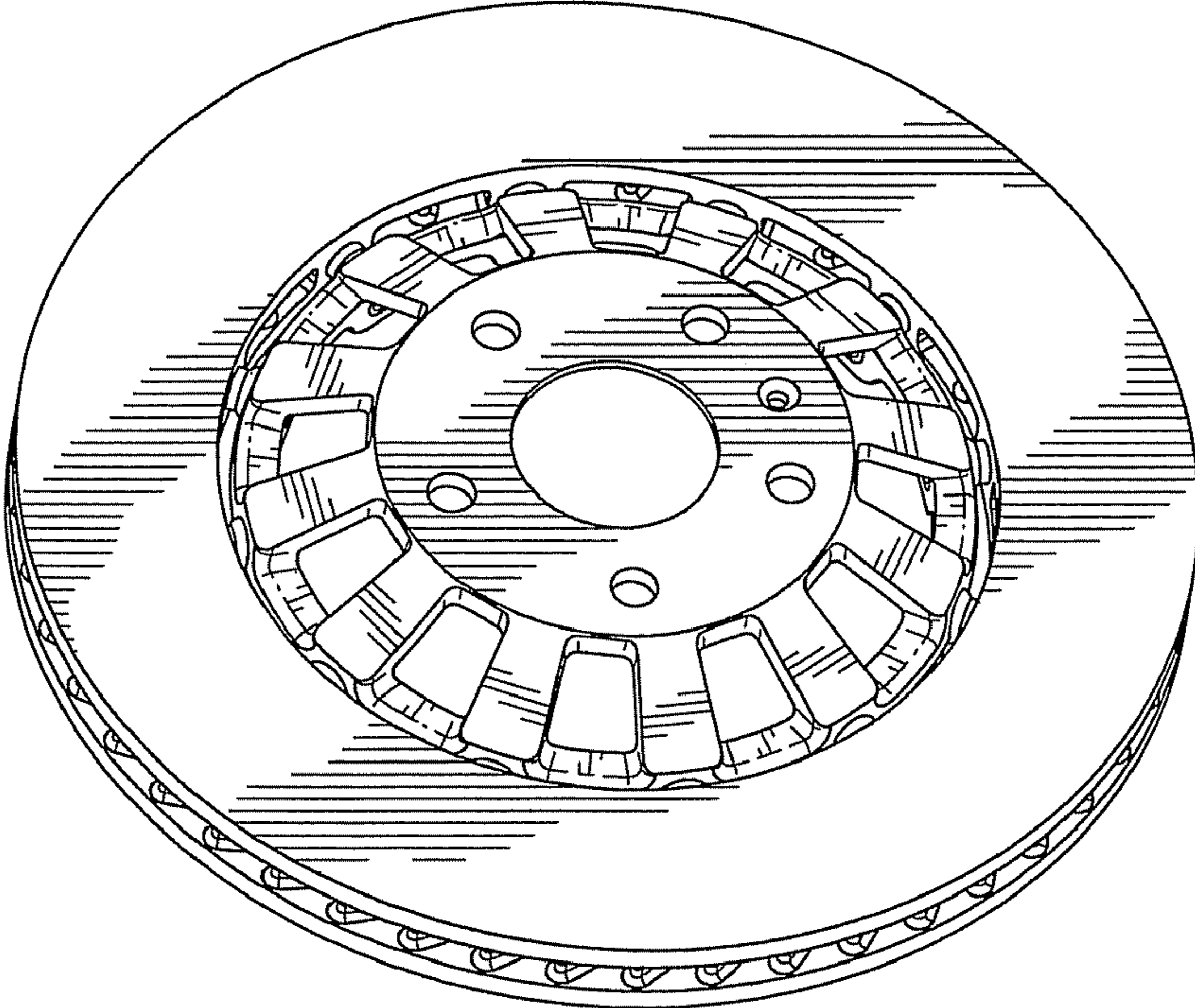

FIG. 2

UNITED STATES PATENT AND TRADEMARK OFFICE
CERTIFICATE OF CORRECTION

PATENT NO. : Des. 605,570 S
APPLICATION NO. : 29/319666
DATED : December 8, 2009
INVENTOR(S) : Johann Schmitz and Ingo Hoffman

Page 1 of 1

It is certified that error appears in the above-identified patent and that said Letters Patent is hereby corrected as shown below:

Title page, item [73] Assignee delete "Schwabische Huttenwerke Automotive GmbH & Co. KG" to read as follows:

--Schwäbische Hüttenwerke Automotive GmbH & Co. KG--

Signed and Sealed this

Twenty-fifth Day of May, 2010

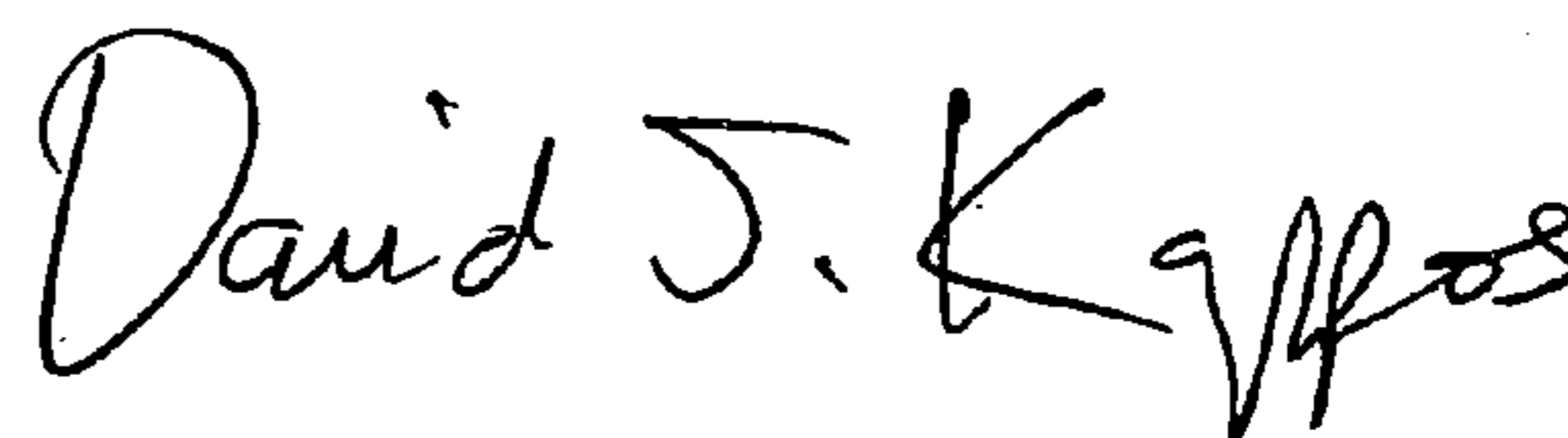

David J. Kappos
Director of the United States Patent and Trademark Office