



US00D605563S

(12) **United States Design Patent**
Huang

(10) **Patent No.:** **US D605,563 S**

(45) **Date of Patent:** **** Dec. 8, 2009**

(54) **MOTORCYCLE**

(75) Inventor: **Kuang-Shih Huang**, Hsinchu County (TW)

(73) Assignee: **Sanyang Industry Co., Ltd.**, Hsinchu County (TW)

(**) Term: **14 Years**

(21) Appl. No.: **29/332,124**

(22) Filed: **Feb. 9, 2009**

(30) **Foreign Application Priority Data**

Dec. 22, 2008 (AU) 16002/2008

(51) **LOC (9) Cl.** **12-11**

(52) **U.S. Cl.** **D12/110**

(58) **Field of Classification Search** D12/110;
180/219, 220

See application file for complete search history.

(56) **References Cited**

U.S. PATENT DOCUMENTS

D475,950 S * 6/2003 Kawano et al. D12/110

D493,122 S * 7/2004 Huang et al. D12/110
D521,415 S * 5/2006 Kojima et al. D12/110
D521,908 S * 5/2006 Hong D12/110
D539,706 S * 4/2007 Huang D12/110

* cited by examiner

Primary Examiner—Phillip S Hyder

Assistant Examiner—Linda G. Brooks

(74) *Attorney, Agent, or Firm*—Quintero Law Office

(57) **CLAIM**

The ornamental design for a motorcycle, as shown and described.

DESCRIPTION

FIG. 1 is a front perspective view thereof;

FIG. 2 is a front elevational view thereof;

FIG. 3 is a rear elevational view thereof;

FIG. 4 is a right side elevational view thereof;

FIG. 5 is a left side elevational view thereof; and,

FIG. 6 is a top plan view thereof.

1 Claim, 6 Drawing Sheets

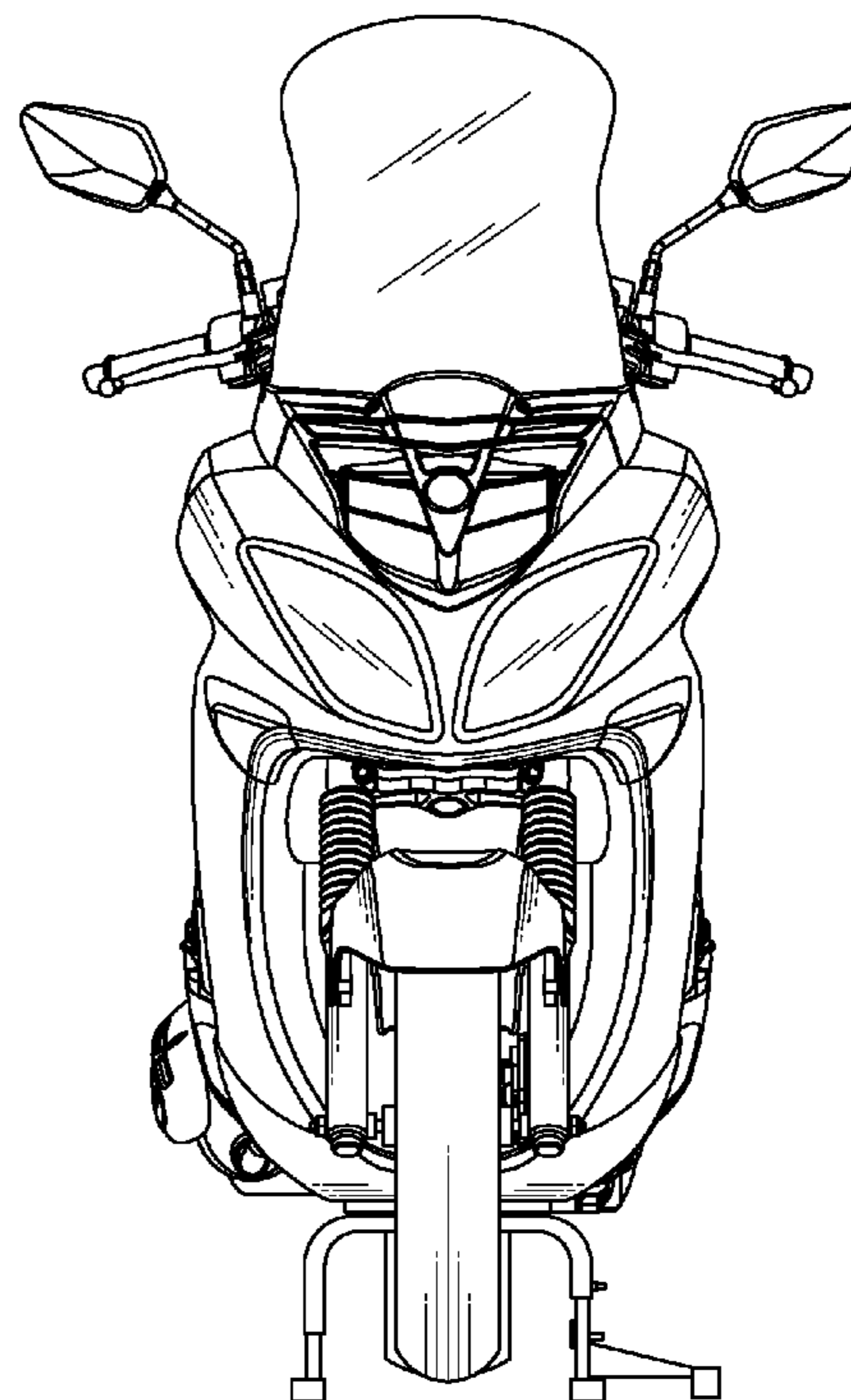
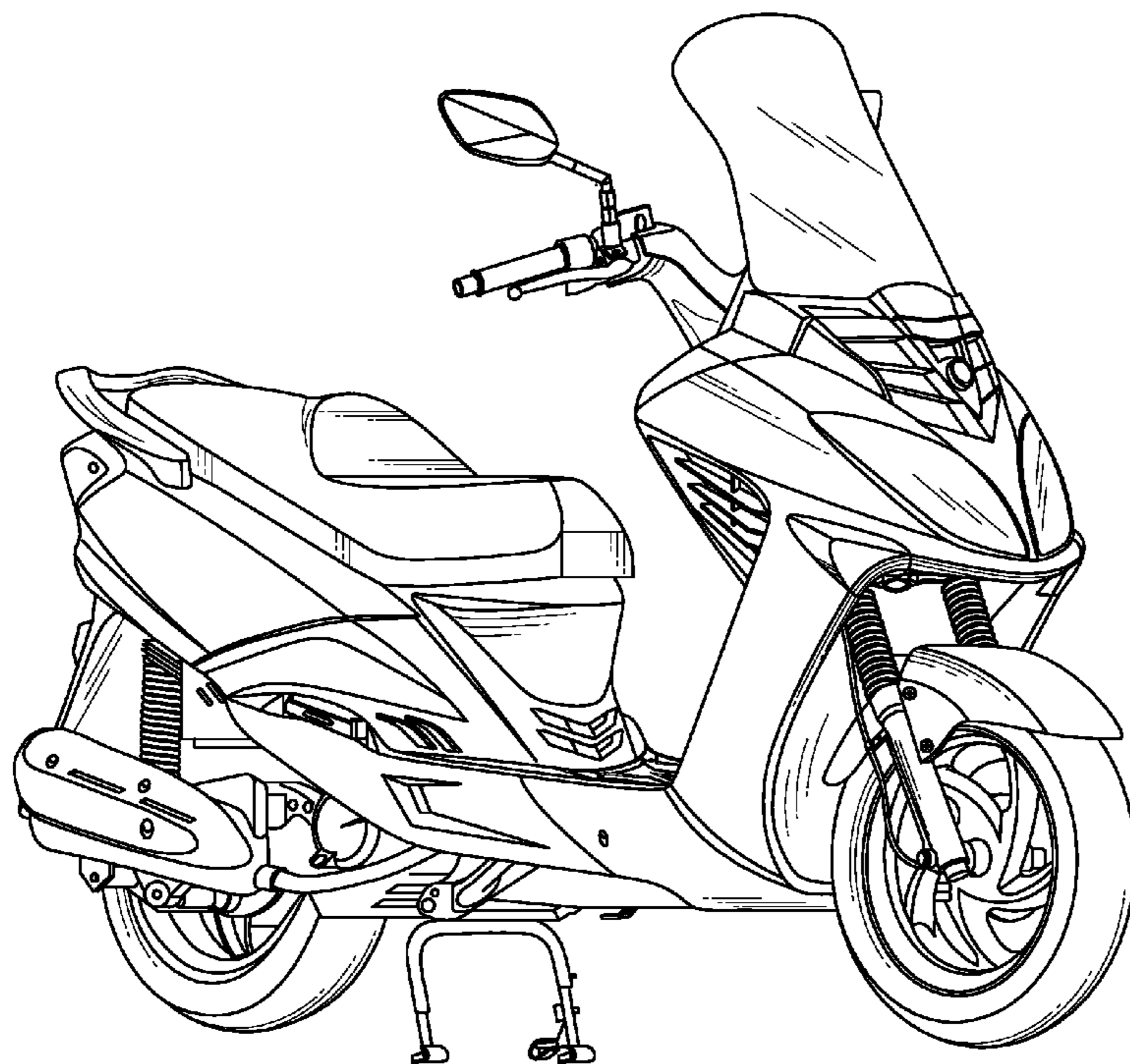

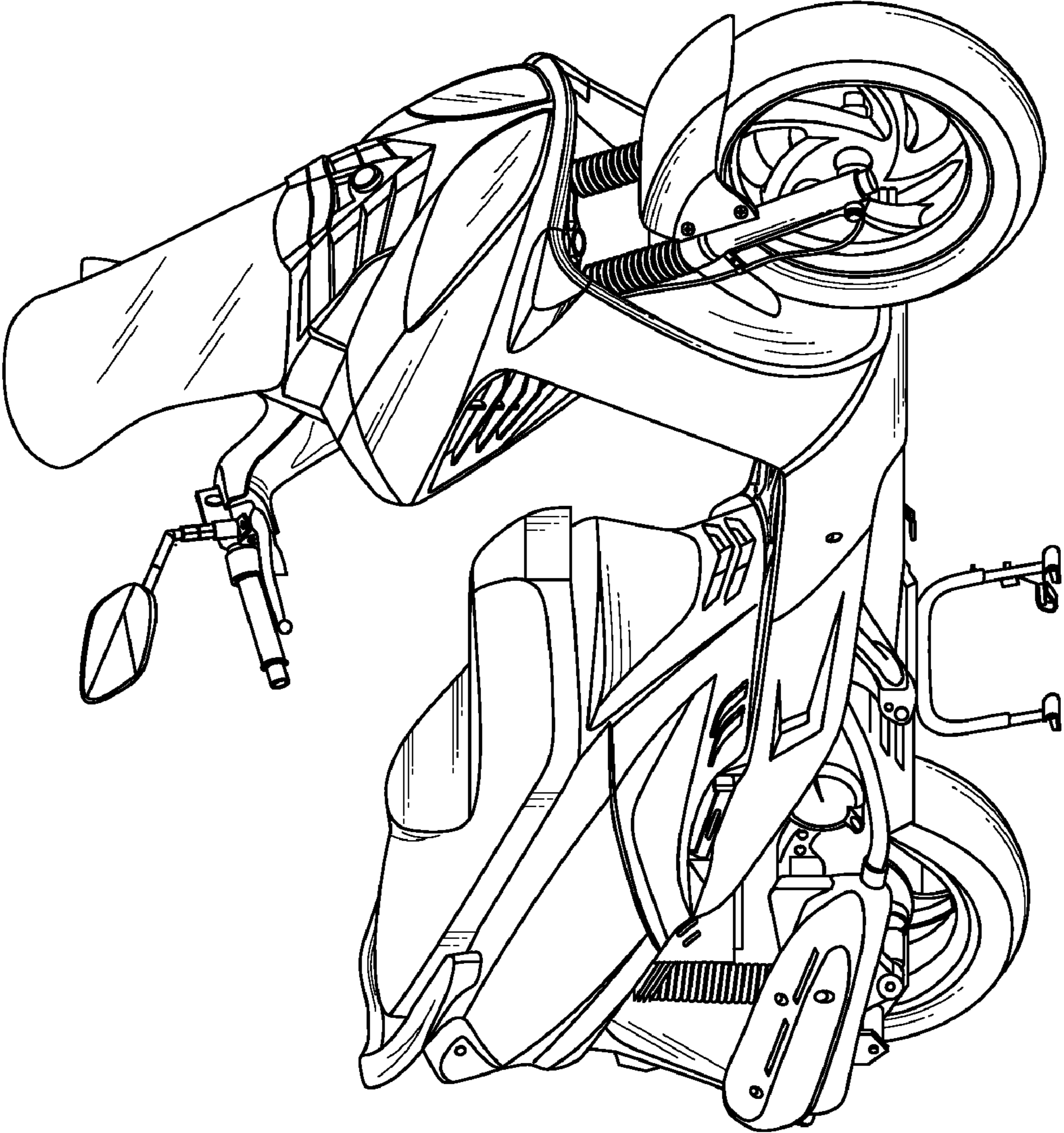

FIG. 1

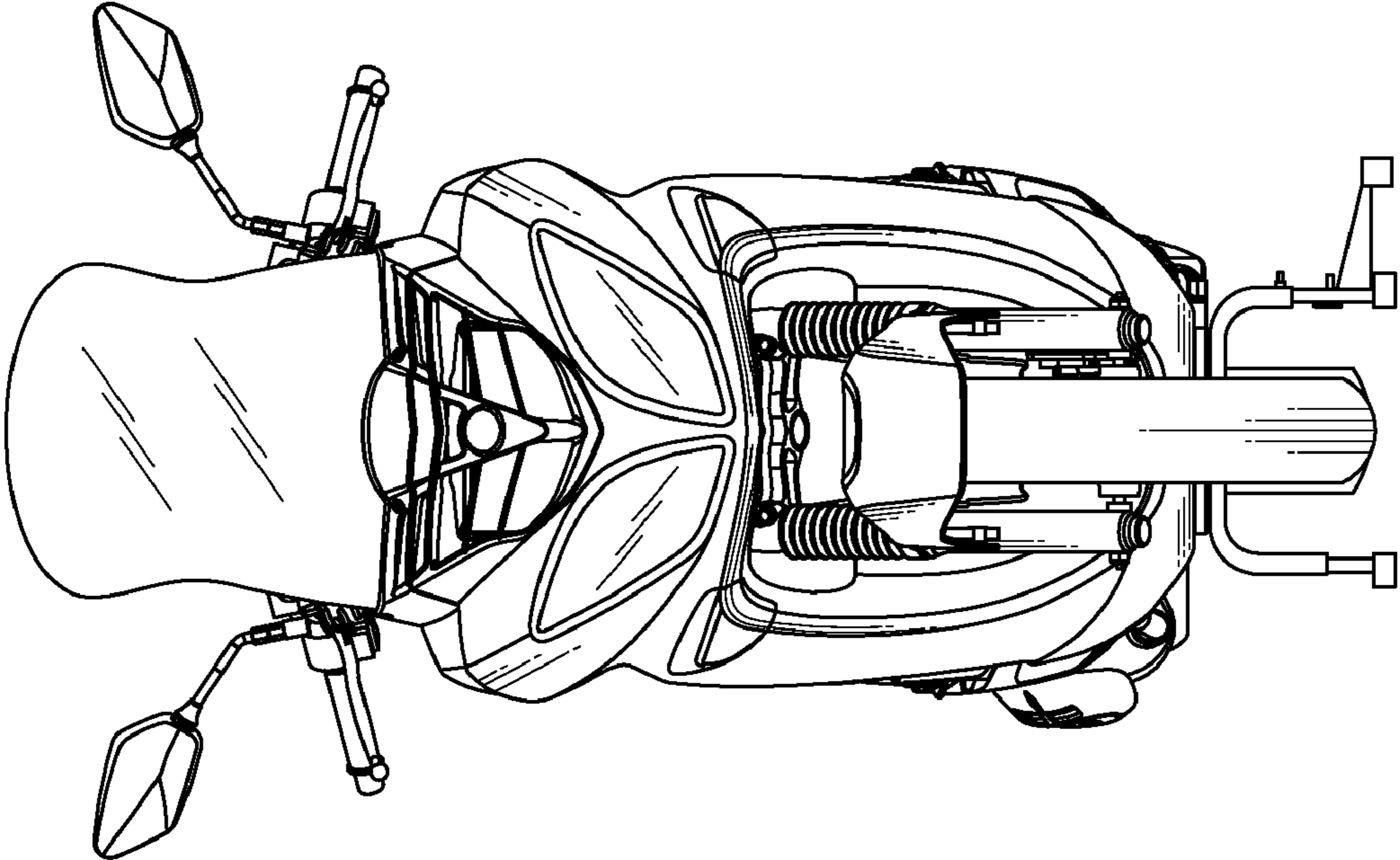

FIG. 2

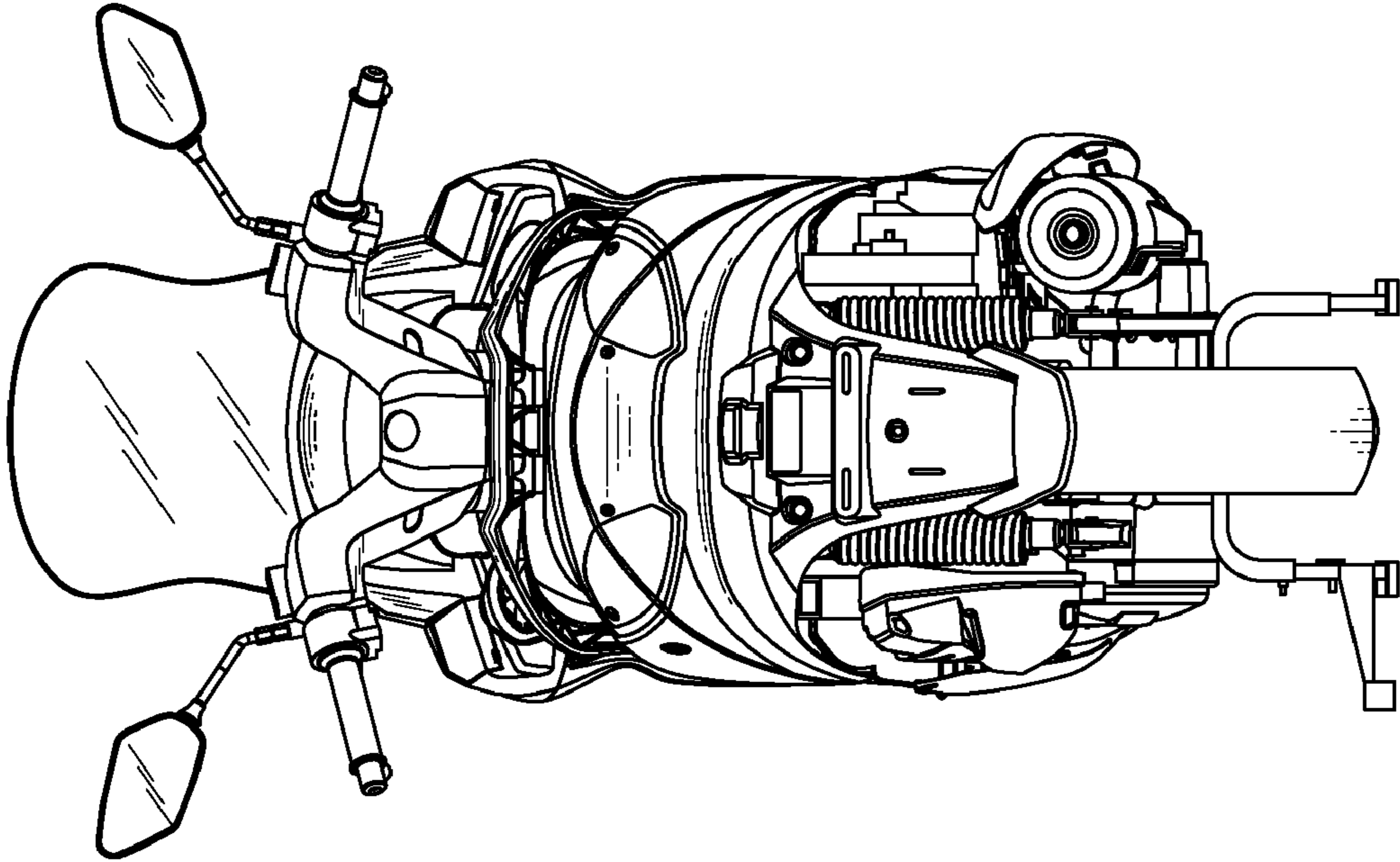

FIG. 3

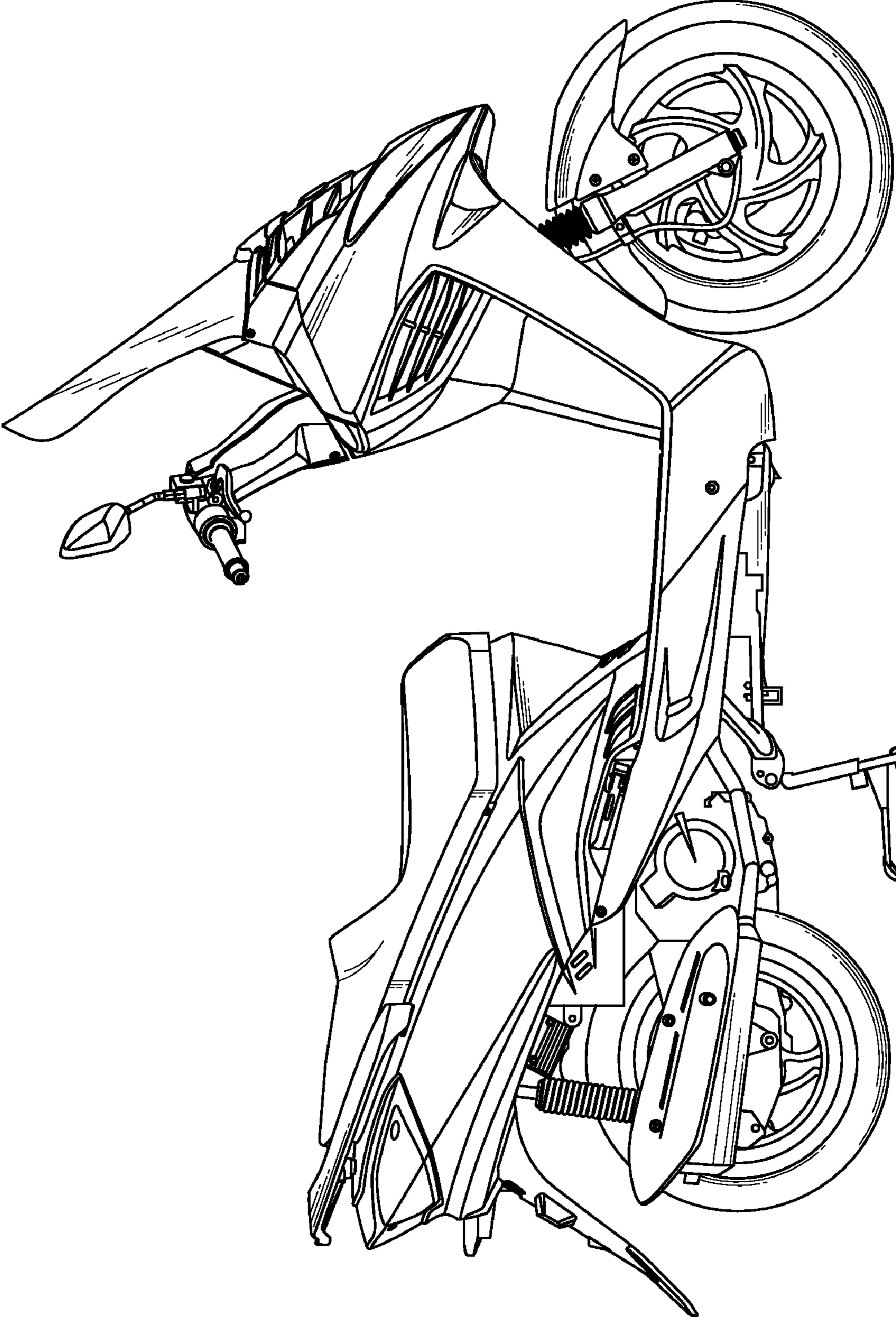

FIG. 4

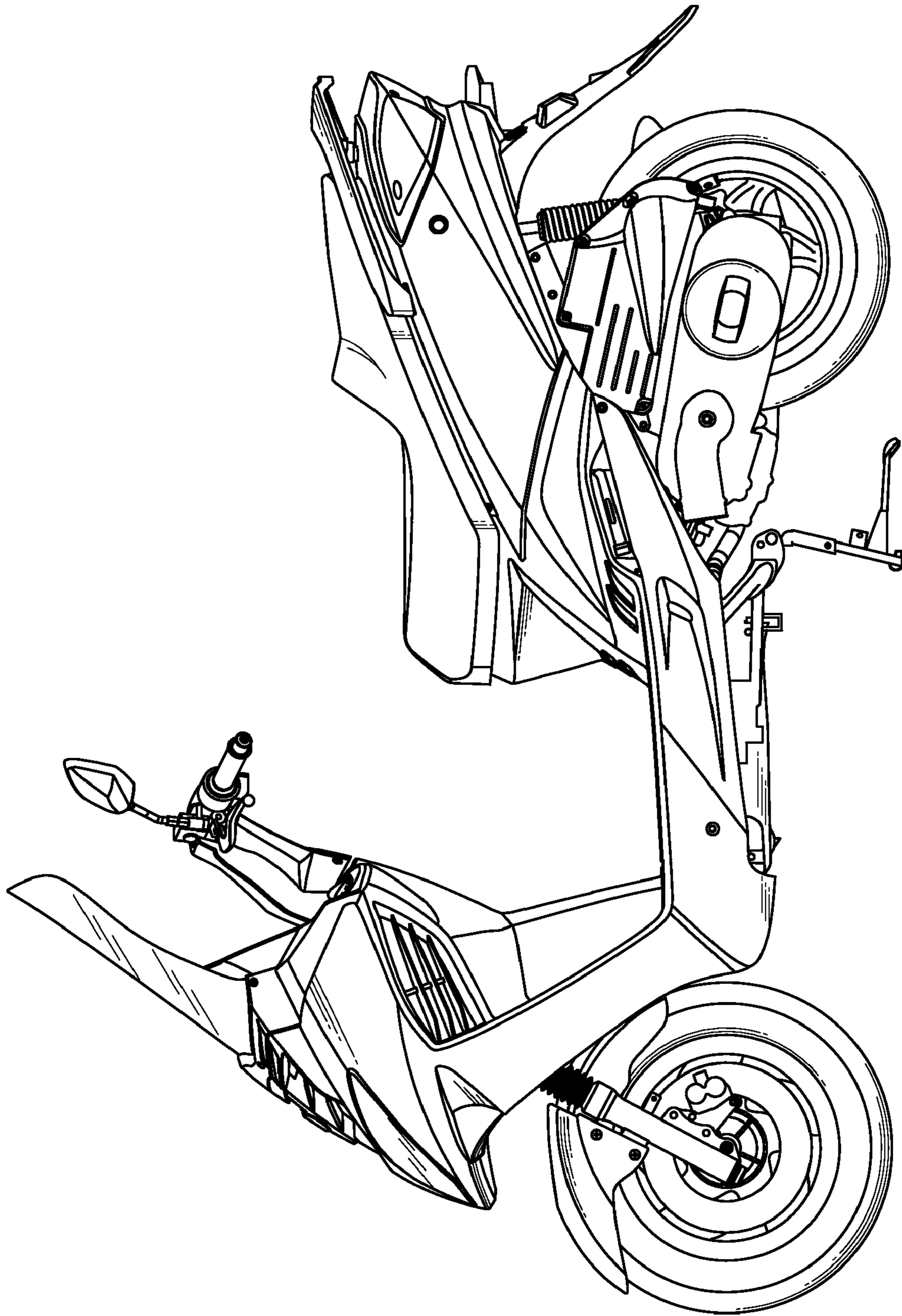

FIG. 5

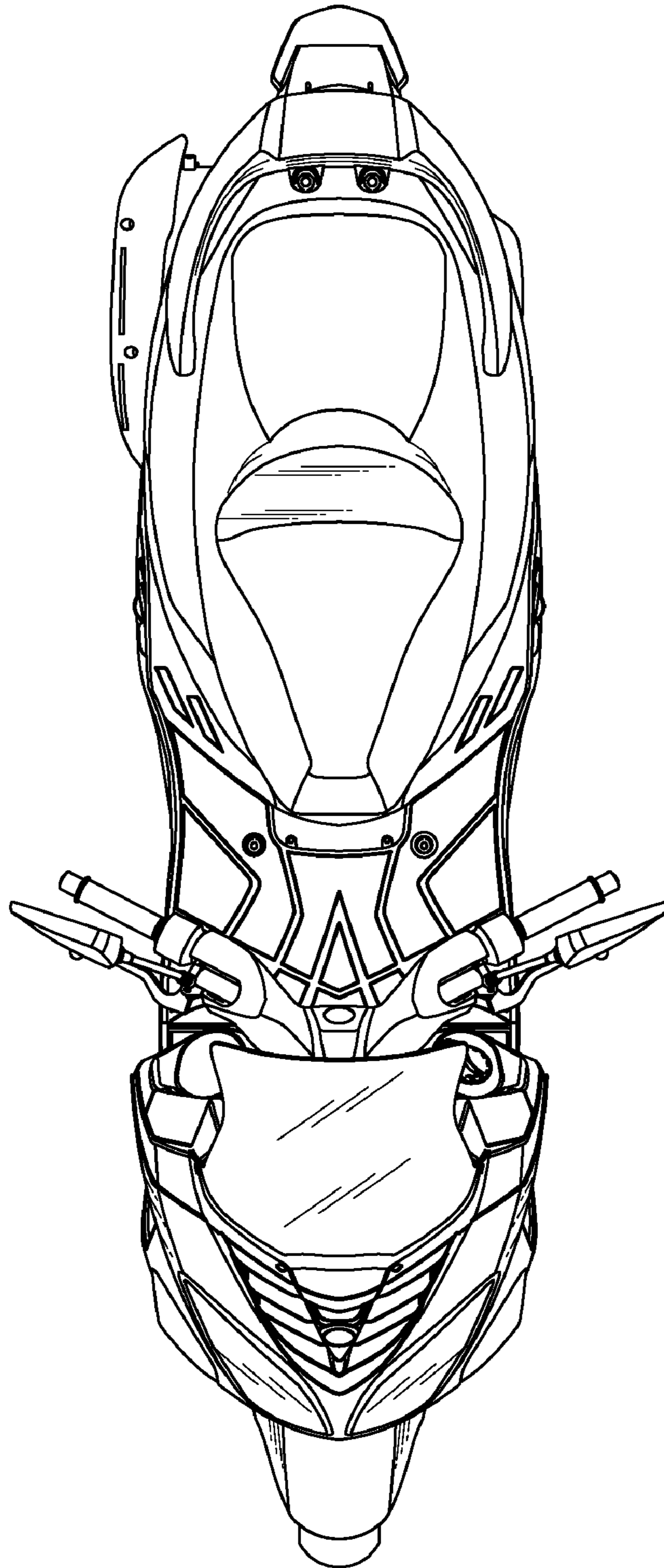

FIG. 6