



US00D605556S

(12) **United States Design Patent**
Zheng

(10) **Patent No.:** **US D605,556 S**

(45) **Date of Patent:** **** Dec. 8, 2009**

(54) **AUTOMOBILE**

(75) Inventor: **Chunhong Zheng**, Baoding (CN)

(73) Assignee: **Great Wall Motor Company Limited**,
Baoding (CN)

(**) Term: **14 Years**

(21) Appl. No.: **29/283,048**

(22) Filed: **Aug. 4, 2007**

(30) **Foreign Application Priority Data**

Apr. 3, 2007 (CN) 2007 3 0007682

(51) **LOC (9) Cl.** **12-08**

(52) **U.S. Cl.** **D12/91**

(58) **Field of Classification Search** D12/86,
D12/90-92; 296/185.1

See application file for complete search history.

(56) **References Cited**

U.S. PATENT DOCUMENTS

- D522,407 S * 6/2006 Kim et al. D12/91
- D531,086 S * 10/2006 Zhang et al. D12/90
- D532,716 S * 11/2006 Moushegian D12/91
- D533,113 S * 12/2006 Cartabiano et al. D12/91
- D539,190 S * 3/2007 Brown et al. D12/91

- D541,702 S * 5/2007 D'Aprile et al. D12/91
- D555,038 S * 11/2007 Suzuki et al. D12/91
- D563,273 S * 3/2008 Zhang et al. D12/91

* cited by examiner

Primary Examiner—Melody N Brown

(74) *Attorney, Agent, or Firm*—Courtney Staniford &
Gregory LLP

(57) **CLAIM**

The ornamental design for an automobile, as shown and described.

DESCRIPTION

FIG. 1 is a front perspective view of the automobile showing our new design.

FIG. 2 is a rear perspective view thereof.

FIG. 3 is a front view thereof.

FIG. 4 is a back view thereof.

FIG. 5 is a left side view thereof.

FIG. 6 is a right side view thereof; and,

FIG. 7 is a top view thereof.

The bottom view has been omitted and forms no part of the claimed design.

1 Claim, 6 Drawing Sheets

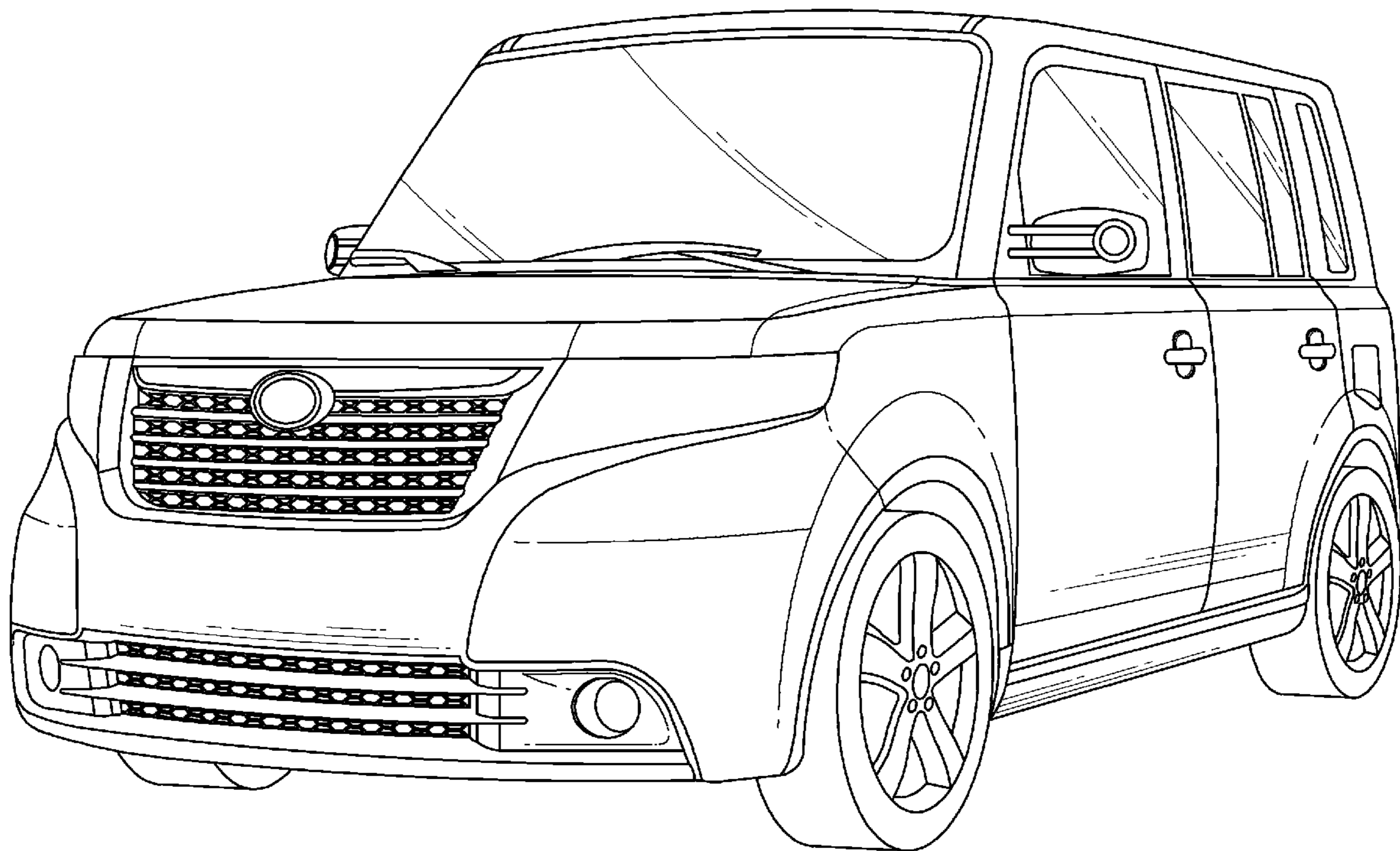

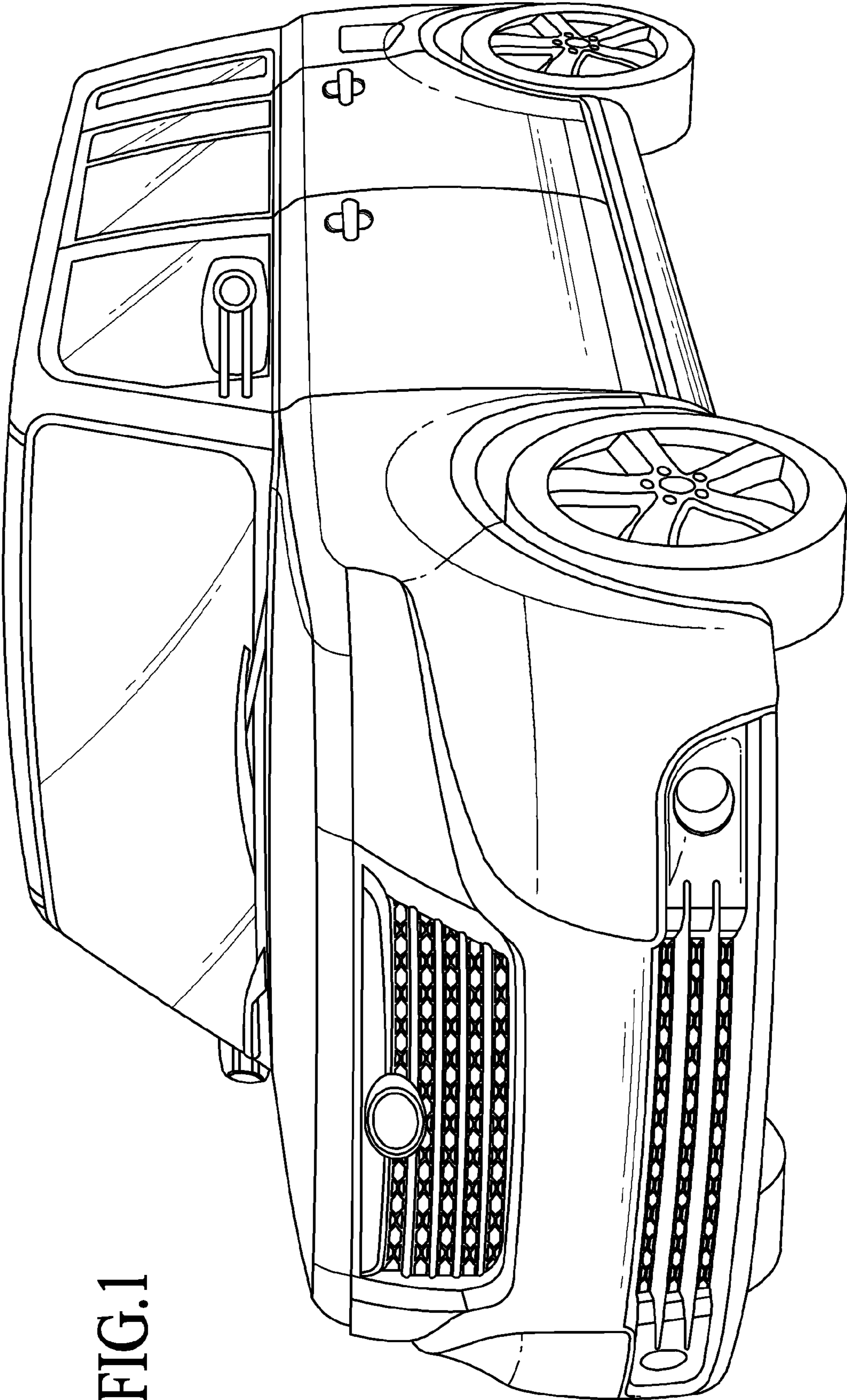

FIG.1

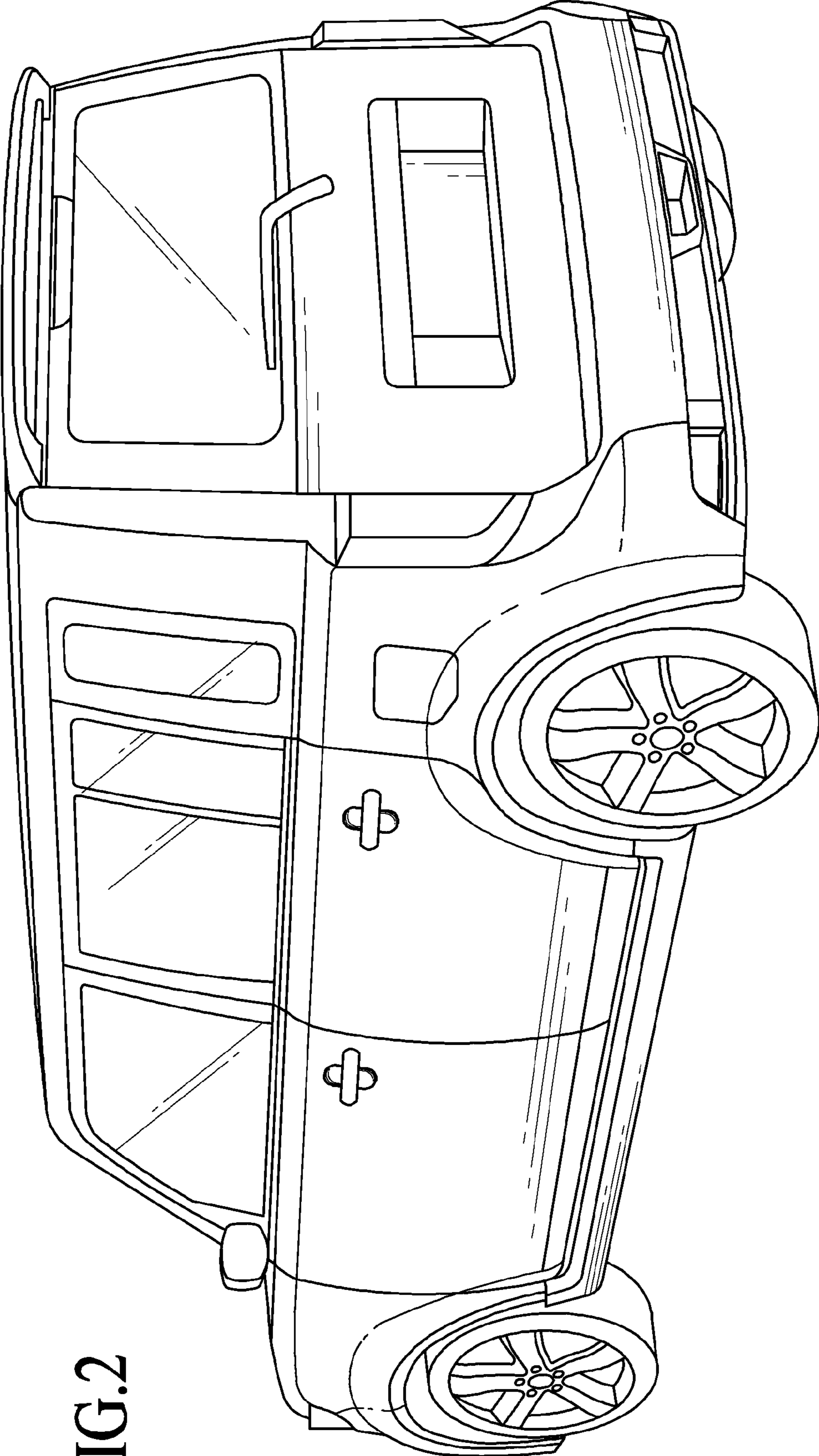

FIG.2

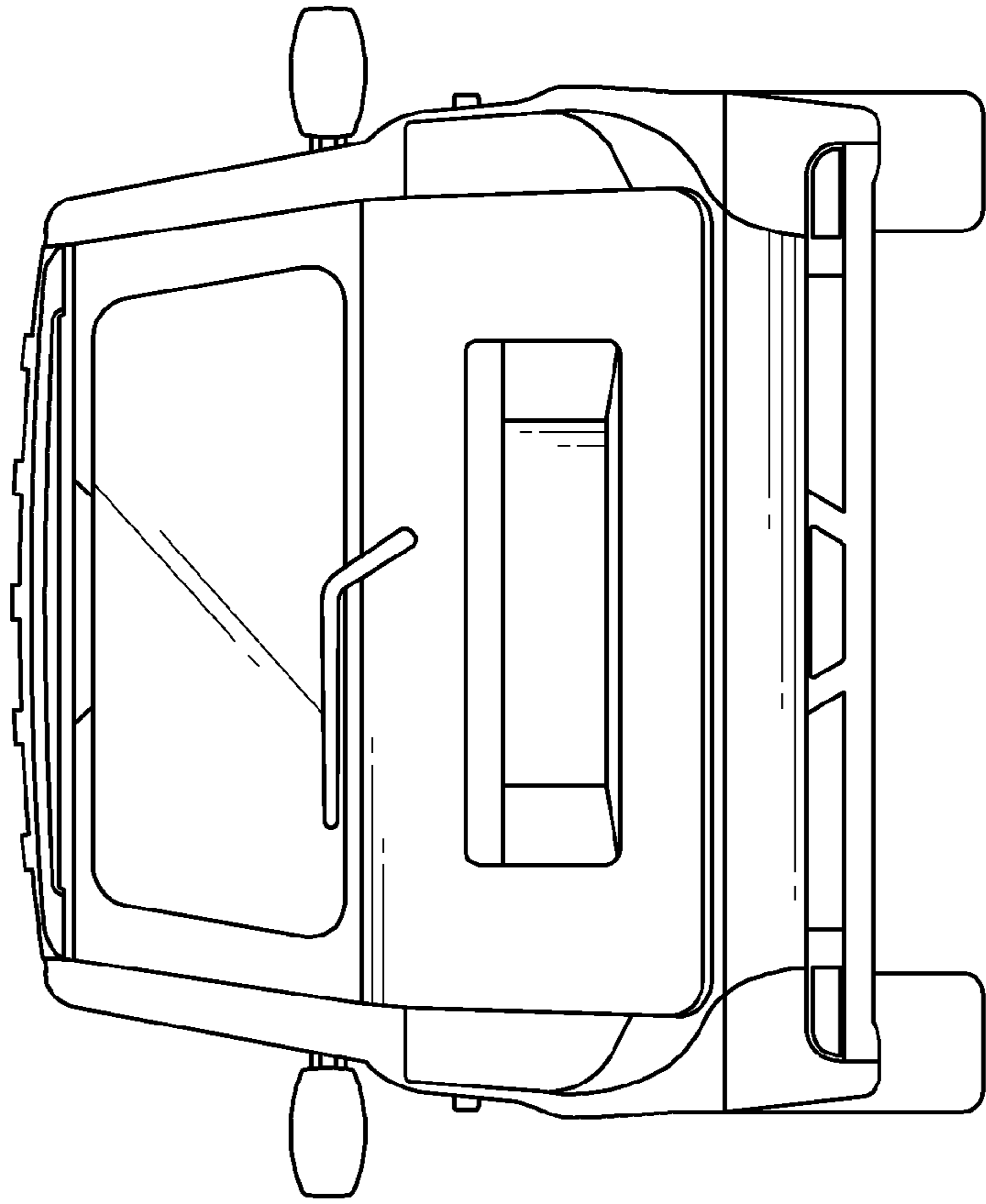

FIG.4

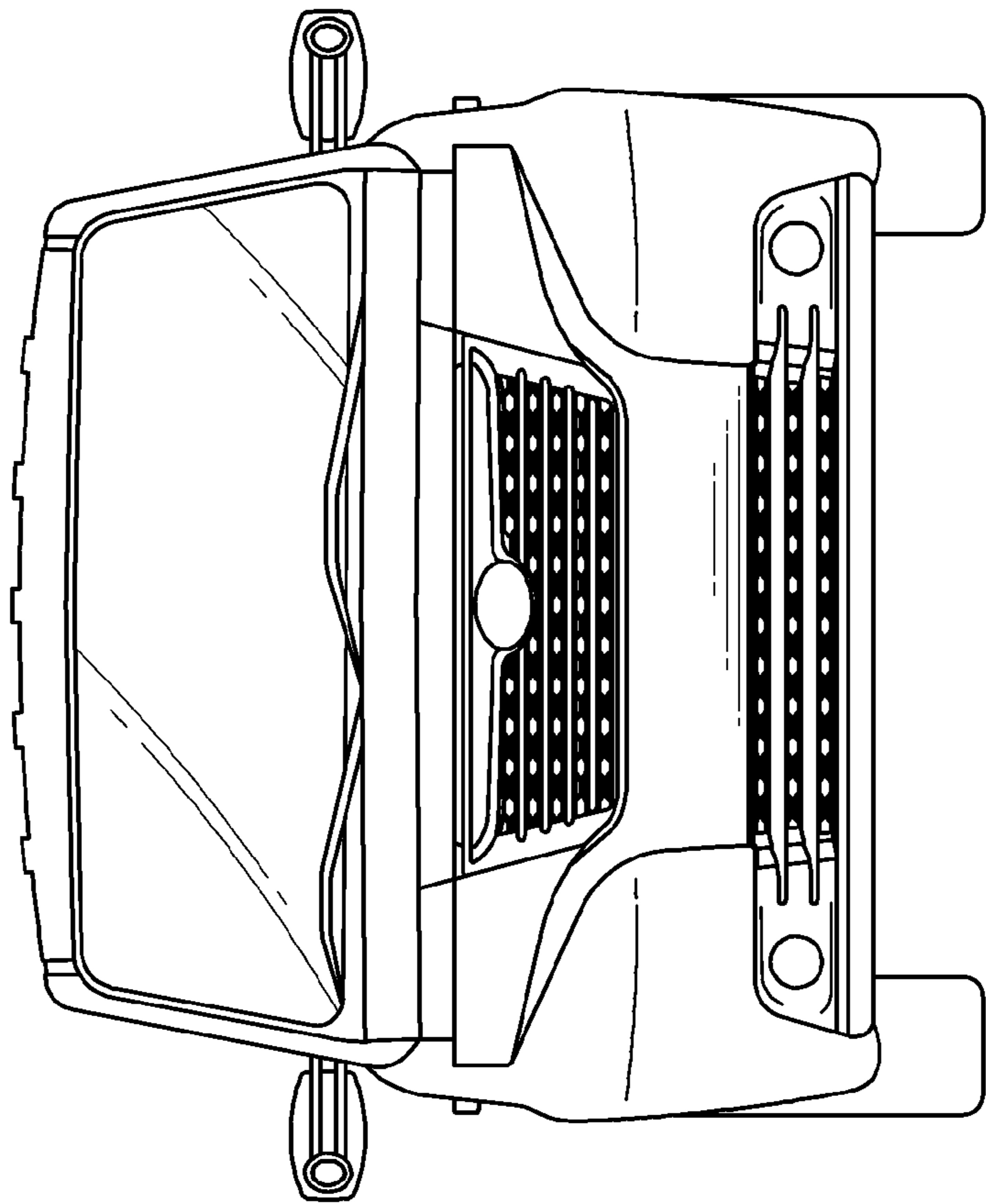

FIG.3

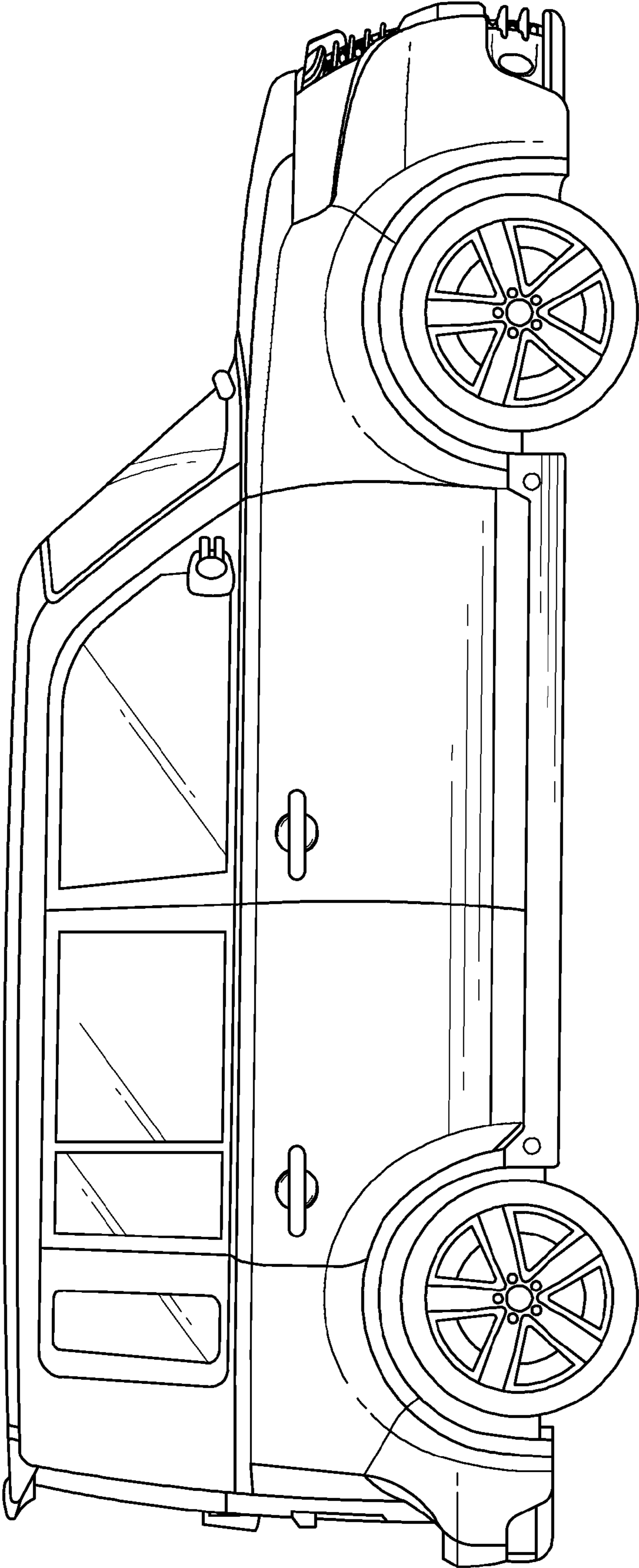

FIG.5

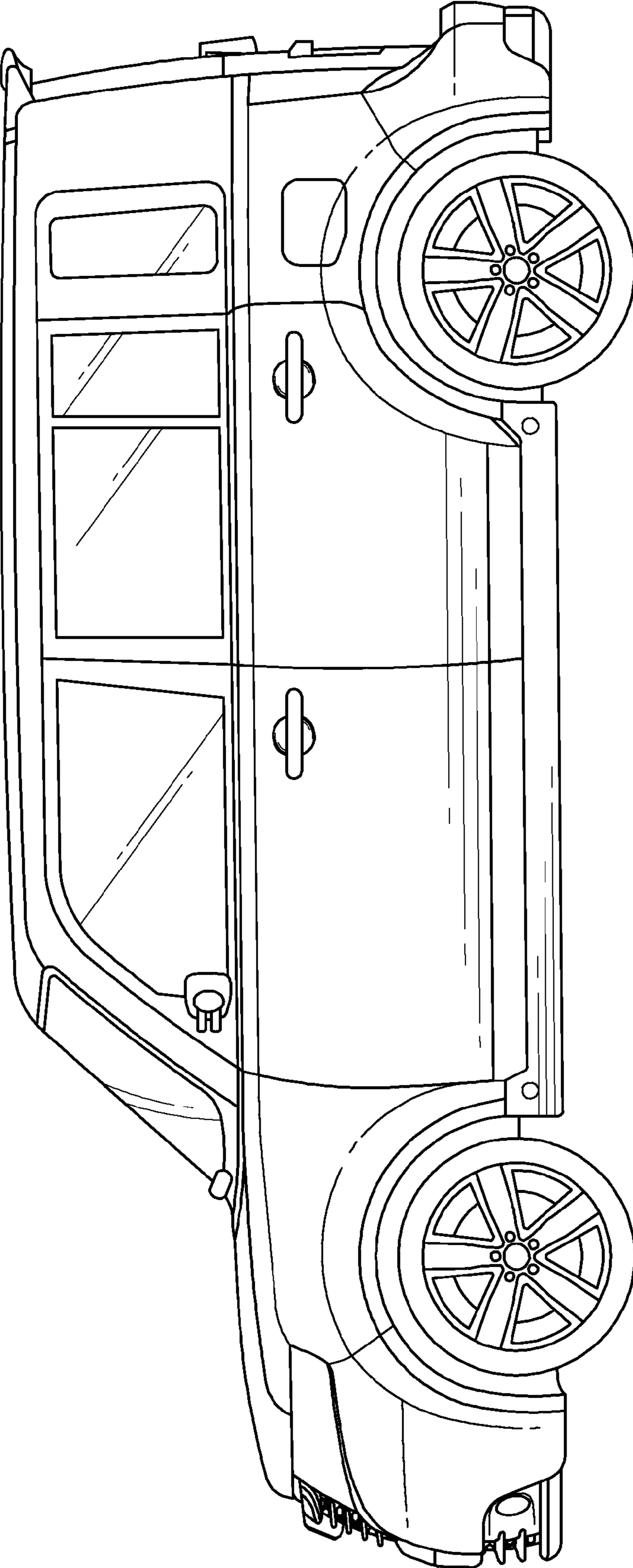

FIG.6

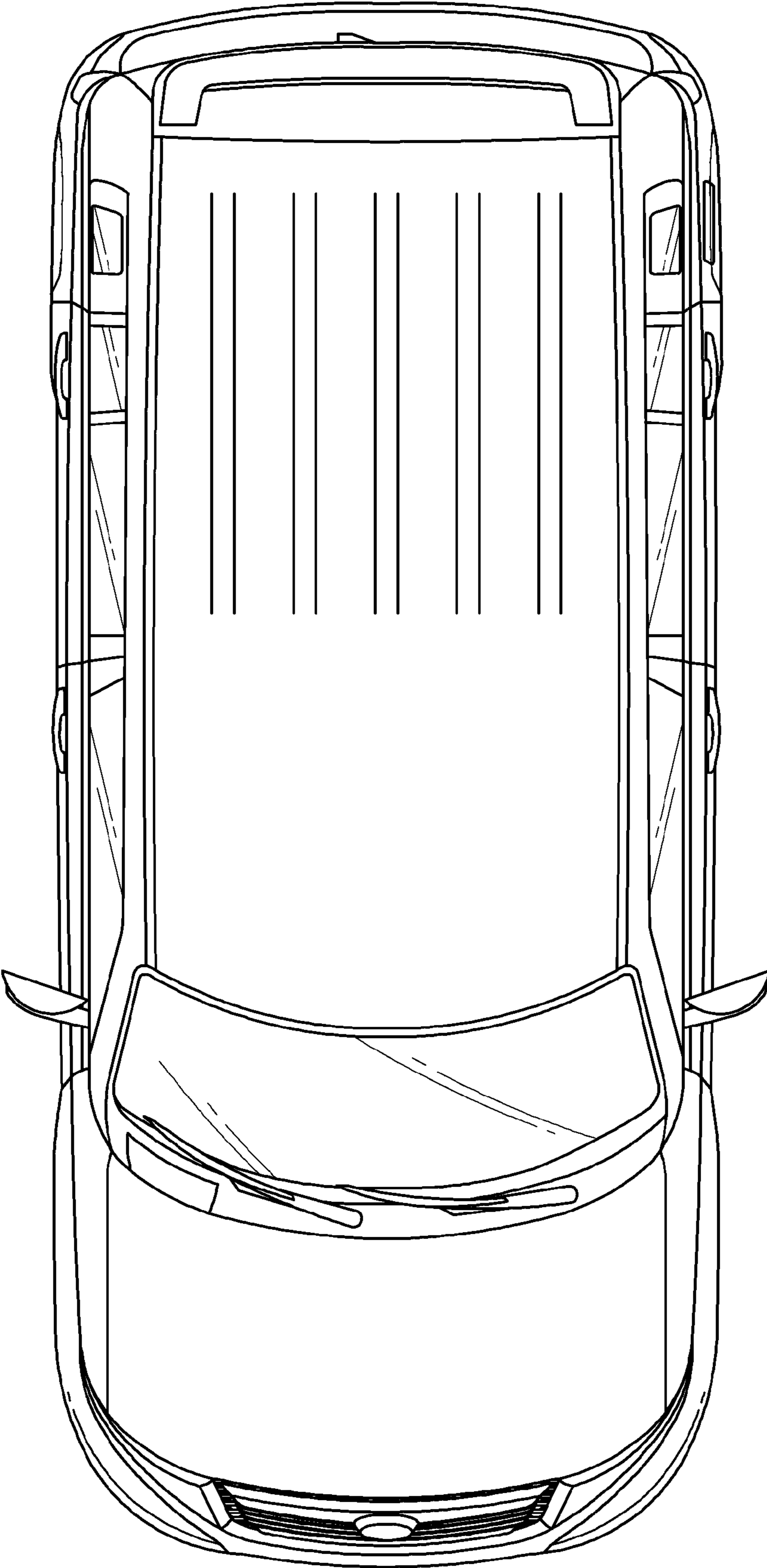

FIG. 7