



US00D605540S

(12) **United States Design Patent**
Shin

(10) **Patent No.:** **US D605,540 S**

(45) **Date of Patent:** **** *Dec. 8, 2009**

(54) **LOW PROFILE LIGHT BAR FOR EMERGENCY VEHICLES**

(76) Inventor: **David D. Shin**, 7322 Madison St.,
Paramount, CA (US) 90723

(*) Notice: This patent is subject to a terminal disclaimer.

(**) Term: **14 Years**

(21) Appl. No.: **29/325,407**

(22) Filed: **Sep. 30, 2008**

(51) **LOC (9) Cl.** **10-05**

(52) **U.S. Cl.** **D10/114**

(58) **Field of Classification Search** D26/28-36;
D10/114; 362/293, 294, 362, 800; 340/815.45,
340/907

See application file for complete search history.

(56) **References Cited**

U.S. PATENT DOCUMENTS

D249,250 S	9/1978	Peirish, Jr.	
D291,870 S	9/1987	Urbanski et al.	
D312,424 S	11/1990	Foster	
D312,425 S	11/1990	Foster	
D312,978 S	12/1990	Foster	
D326,621 S	6/1992	Jincks et al.	
D345,315 S *	3/1994	Green et al.	D10/114
D345,316 S	3/1994	Green et al.	
D355,142 S *	2/1995	Wagner	D10/114
5,452,188 A	9/1995	Green et al.	
D363,675 S *	10/1995	Sasaki et al.	D10/114
D402,909 S	12/1998	Stanuch	
D410,402 S *	6/1999	Stein et al.	D10/114
D427,537 S	7/2000	Green et al.	
D432,038 S	10/2000	Sasaki et al.	
D432,444 S	10/2000	Sasaki et al.	
6,140,918 A	10/2000	Green et al.	

D469,711 S	2/2003	Neufeglise	
D476,253 S	6/2003	Stein et al.	
D499,976 S	12/2004	Neufeglise	
D518,400 S	4/2006	Sasaki et al.	
D545,230 S *	6/2007	Jalala	D10/114
D556,074 S	11/2007	Stein et al.	
D578,425 S *	10/2008	Shin	D10/114

* cited by examiner

Primary Examiner—Marcus A Jackson

(74) *Attorney, Agent, or Firm*—Kirk A. Buhler; Buhler & Associates

(57) **CLAIM**

The ornamental design for a low profile light bar for emergency vehicles, as shown and described.

DESCRIPTION

FIG. 1 is a top, view for a low profile light bar for emergency vehicles showing my new design;

FIG. 2 is a bottom view thereof;

FIG. 3 is a front view thereof;

FIG. 4 is a back view thereof;

FIG. 5 is a left view thereof;

FIG. 6 is a right view thereof;

FIG. 7 is an isometric view thereof; and,

FIG. 8 is a view of the low profile light bar for emergency vehicles mounted on the roof of vehicle.

The broken lines in FIG. 1, FIG. 2 and FIG. 7 depict environmental subject matter of mounting hardware for the invention and form no part of the claimed design.

The broken lines in FIG. 8 depict environmental subject matter of mounting hardware for the invention on a vehicle only and form no part of the claimed design.

1 Claim, 5 Drawing Sheets

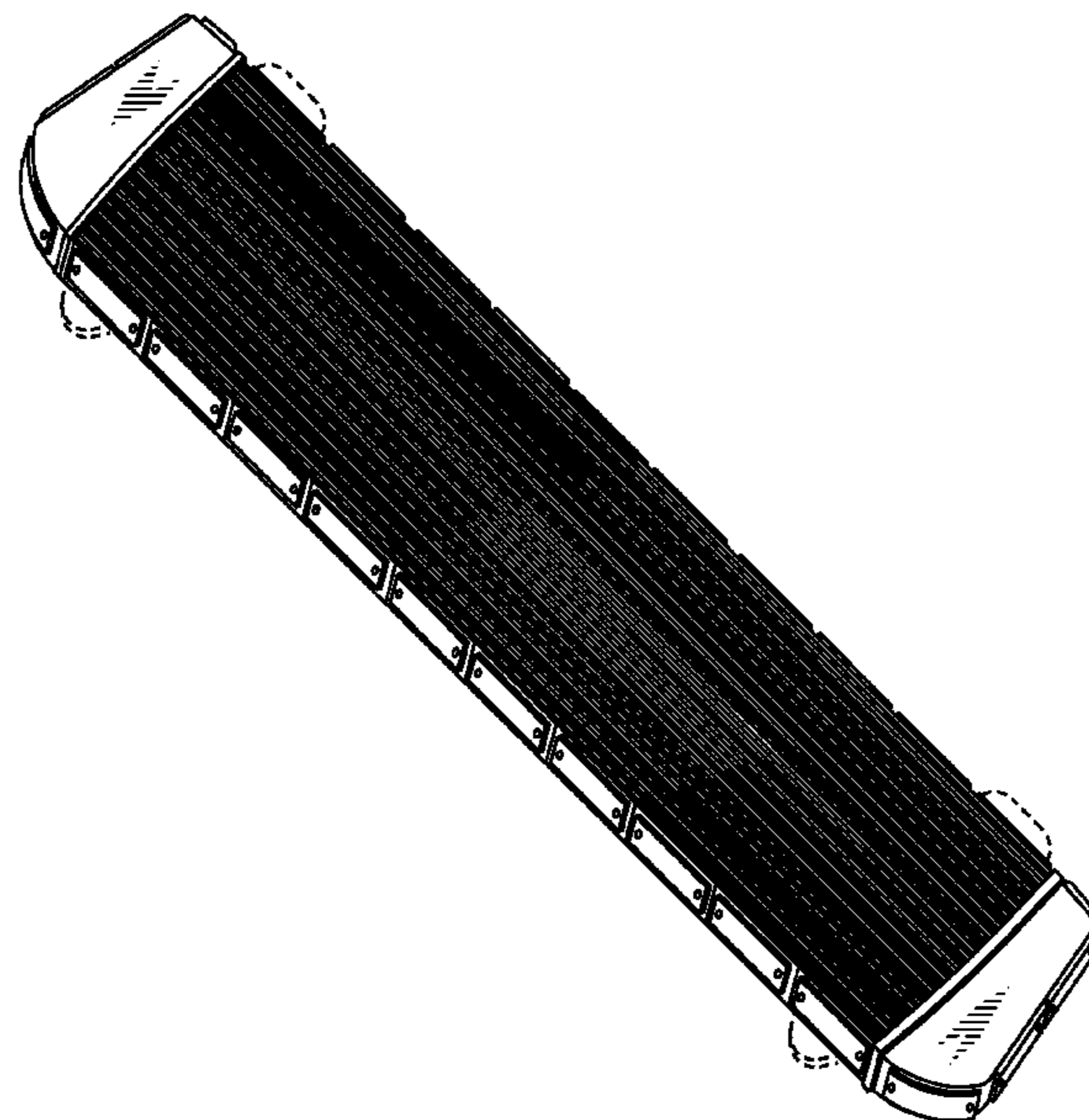

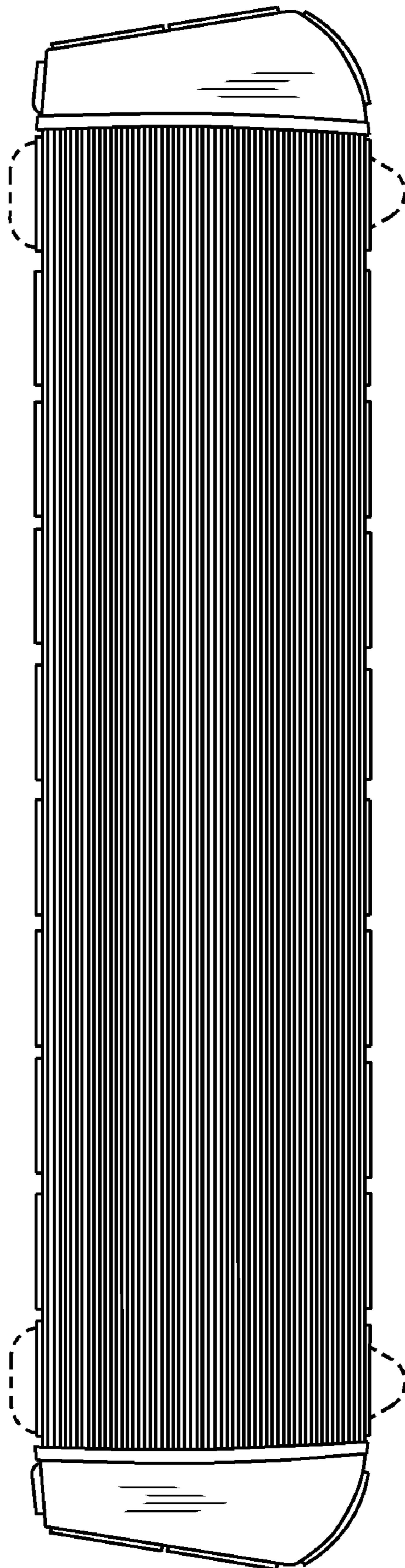

FIG. 1

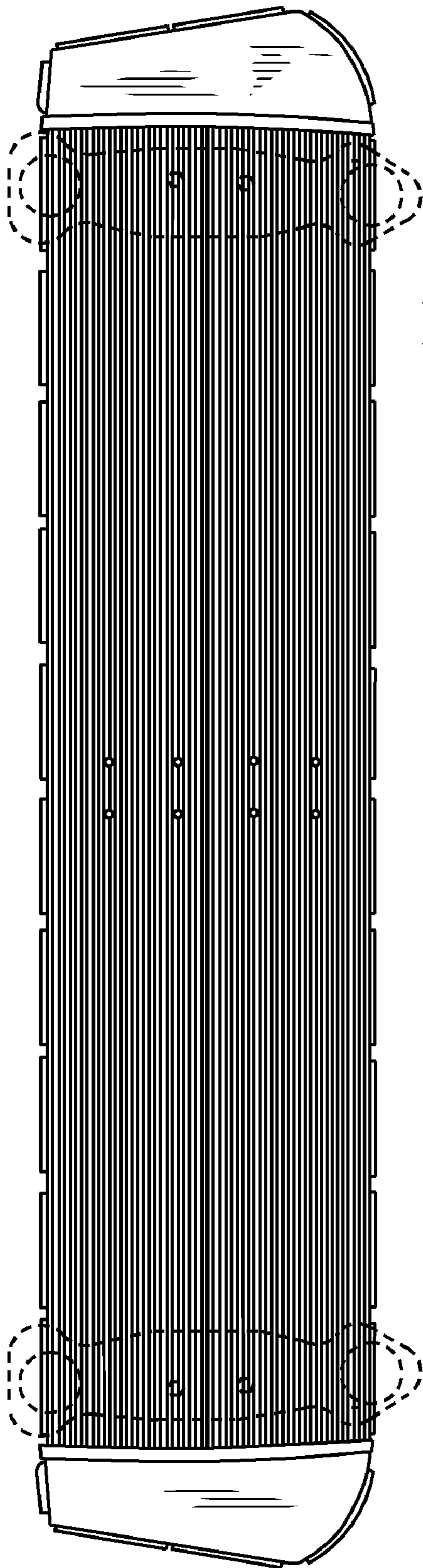

FIG. 2



FIG. 3

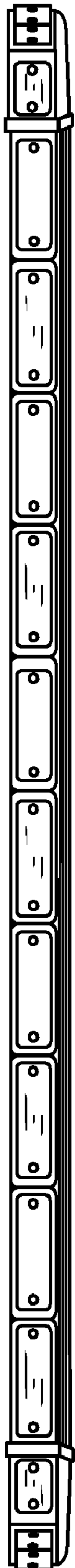

FIG. 4

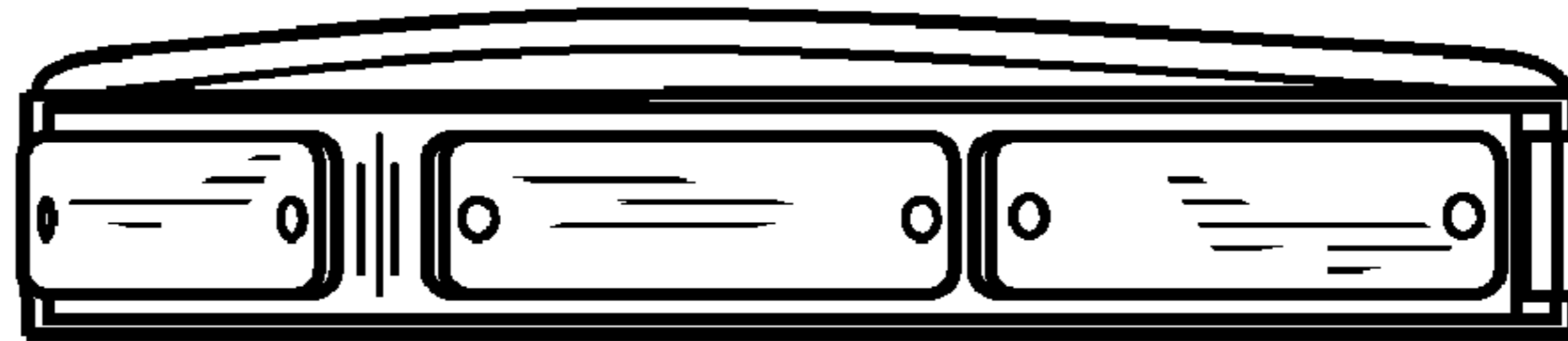

FIG. 5

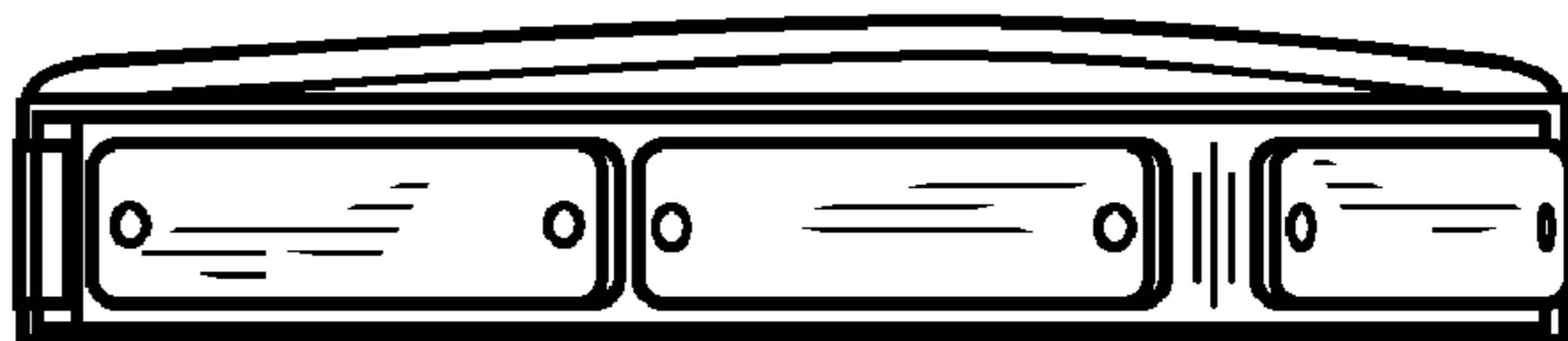

FIG. 6

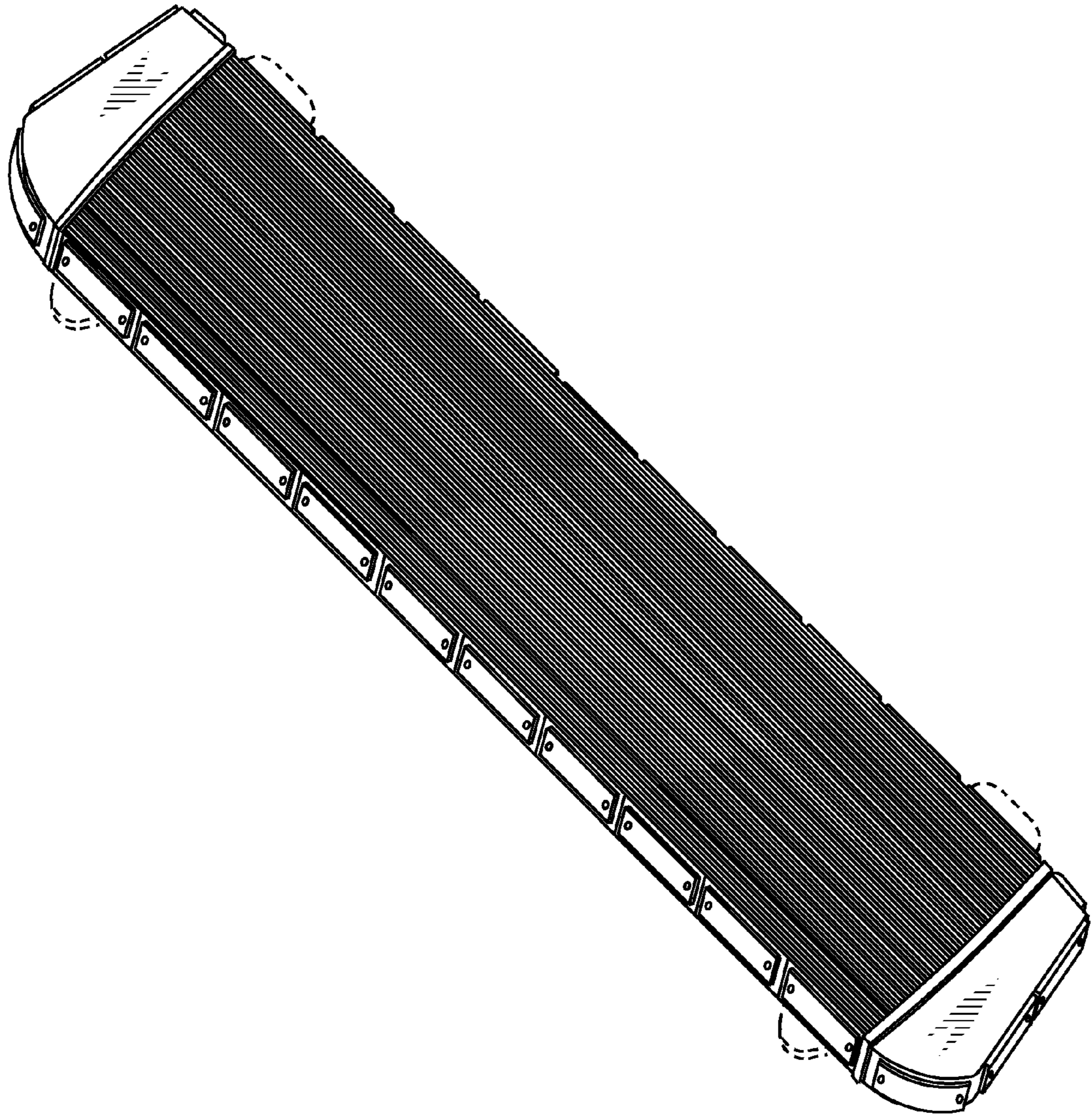

FIG. 7

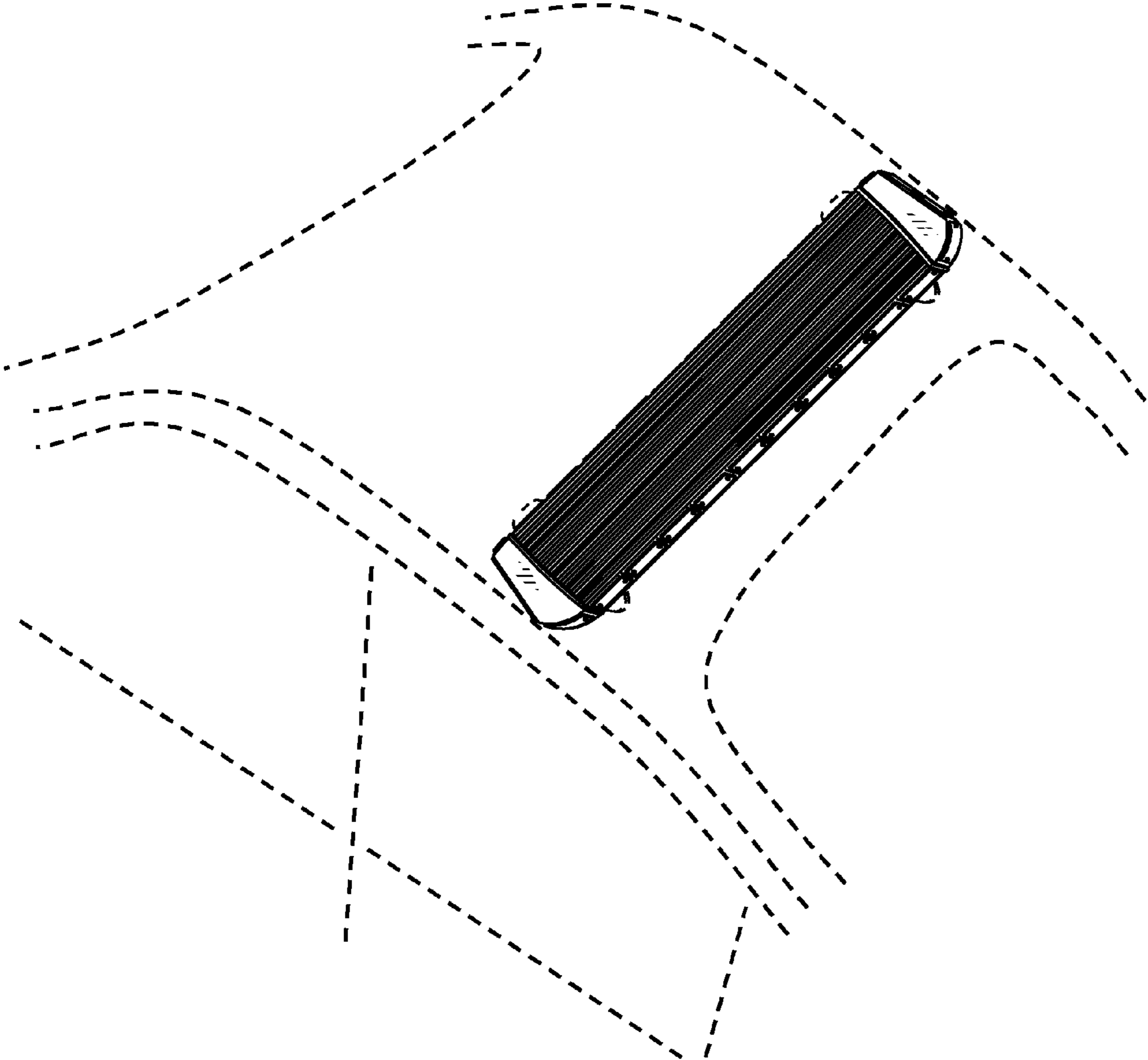

FIG. 8