



US00D605287S

(12) **United States Design Patent**  
**Crawford et al.**

(10) **Patent No.:** **US D605,287 S**  
(45) **Date of Patent:** **\*\* Dec. 1, 2009**

(54) **SAFETY BLOOD COLLECTION ASSEMBLY**

**DESCRIPTION**

(75) Inventors: **Jamieson Crawford**, Cliffside Park, NJ (US); **Bradley M. Wilkinson**, North Haledon, NJ (US)

(73) Assignee: **Becton, Dickinson and Company**, Franklin Lakes, NJ (US)

(\*\*) Term: **14 Years**

(21) Appl. No.: **29/304,796**

(22) Filed: **Mar. 7, 2008**

(51) **LOC (9) Cl.** ..... **24-02**

(52) **U.S. Cl.** ..... **D24/130**

(58) **Field of Classification Search** ..... D24/112, D24/130, 113, 146; 604/110, 192, 195-196, 604/198, 410, 576-578, 583; 263/363-365  
See application file for complete search history.

(56) **References Cited**

**U.S. PATENT DOCUMENTS**

4,573,976 A 3/1986 Sampson et al.  
4,641,663 A 2/1987 Juhn  
4,795,443 A 1/1989 Permenter et al.

(Continued)

**OTHER PUBLICATIONS**

U.S. Appl. No. 11/572,220; filed Aug. 26, 2008; Swenson.

(Continued)

*Primary Examiner*—T. Chase Nelson

*Assistant Examiner*—Eric L Goodman

(74) *Attorney, Agent, or Firm*—The Webb Law Firm

(57) **CLAIM**

The ornamental design for a safety blood collection assembly, as shown and described.

FIG. 1 is a perspective view of a safety blood collection assembly having an exposed needle, and with the needle shield removed, in accordance with an embodiment of the present invention;

FIG. 2 is a top view of the safety blood collection assembly of FIG. 1;

FIG. 3 is a left side view of the safety blood collection assembly of FIG. 1;

FIG. 4 is a front view of the safety blood collection assembly of FIG. 1;

FIG. 5 is a rear view of the safety blood collection assembly of FIG. 1;

FIG. 6 is right side view of the safety blood collection assembly of FIG. 1;

FIG. 7 is a bottom view of the safety blood collection assembly of FIG. 1;

FIG. 8 is a perspective view of the safety blood collection assembly of FIG. 1 having a needle shield disposed thereon in accordance with an embodiment of the present invention;

FIG. 9 is a top view of the safety blood collection assembly of FIG. 8;

FIG. 10 is a left side view of the safety blood collection assembly of FIG. 8;

FIG. 11 is a front view of the safety blood collection assembly of FIG. 8;

FIG. 12 is a rear view of the safety blood collection assembly of FIG. 8;

FIG. 13 is a right side view of the safety blood collection assembly of FIG. 8; and,

FIG. 14 is a bottom view of the safety blood collection assembly of FIG. 8.

The portions of the safety blood collection assembly shown in broken lines in FIGS. 5, 11, and 12 form no part of the claimed design.

**1 Claim, 8 Drawing Sheets**

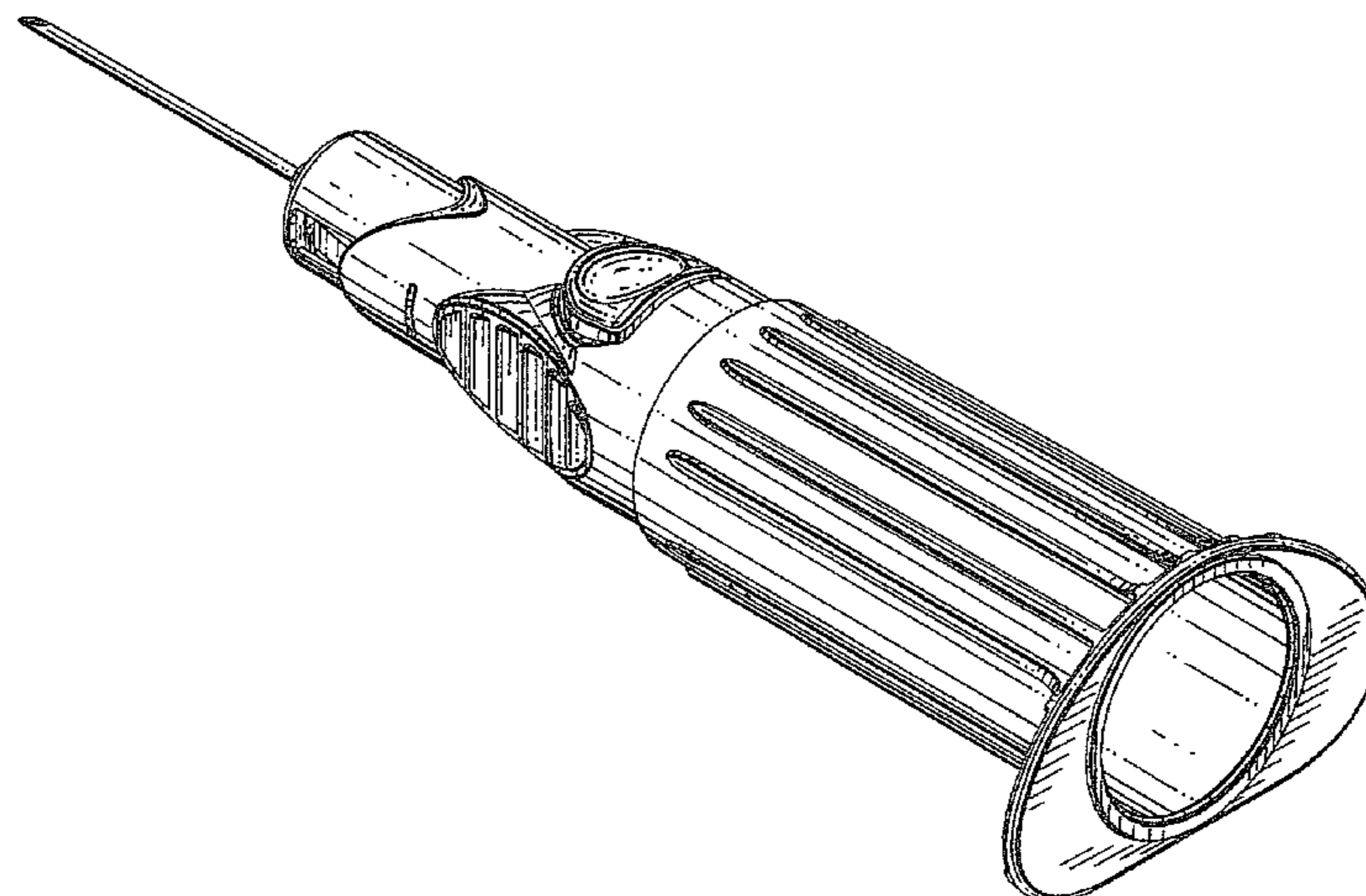

U.S. PATENT DOCUMENTS

4,840,619 A	6/1989	Hughes		6,699,217 B2	3/2004	Bennett et al.	
4,894,055 A	1/1990	Sudnak		6,712,792 B2	3/2004	Leong	
4,900,307 A	2/1990	Kulli		6,780,169 B2	8/2004	Crawford	
4,994,046 A	2/1991	Wesson et al.		6,837,877 B2	1/2005	Zurcher	
5,015,241 A	5/1991	Feimer		6,869,415 B2	3/2005	Asbaghi	
5,215,534 A	6/1993	De Harde et al.		6,905,483 B2 *	6/2005	Newby et al. ....	604/164.08
5,222,502 A	6/1993	Kurose		6,949,086 B2 *	9/2005	Ferguson et al. ....	604/198
5,242,417 A	9/1993	Paudler		6,984,223 B2 *	1/2006	Newby et al. ....	604/263
5,303,713 A	4/1994	Kurose		6,997,913 B2 *	2/2006	Wilkinson .....	604/263
5,312,372 A	5/1994	DeHarde et al.		7,001,363 B2	2/2006	Ferguson et al.	
5,336,199 A	8/1994	Castillo et al.		7,041,066 B2 *	5/2006	Wilkinson .....	600/576
5,348,544 A	9/1994	Sweeney et al.		7,063,673 B2 *	6/2006	Marsden .....	600/576
5,356,392 A	10/1994	Firth et al.		7,128,726 B2	10/2006	Crawford et al.	
5,411,492 A	5/1995	Sturman et al.		7,147,624 B2	12/2006	Hirsiger et al.	
5,466,223 A	11/1995	Bressler et al.		7,163,526 B2	1/2007	Leong et al.	
5,501,675 A	3/1996	Erskine		7,182,734 B2 *	2/2007	Saulenas et al. ....	600/573
5,672,161 A	9/1997	Allen et al.		7,198,618 B2 *	4/2007	Ferguson et al. ....	604/198
5,676,658 A	10/1997	Erskine		7,201,740 B2 *	4/2007	Crawford .....	604/198
5,702,369 A	12/1997	Mercereau		7,223,258 B2	5/2007	Crawford	
5,704,920 A	1/1998	Gyure		7,428,773 B2	9/2008	Newby et al.	
5,755,522 A	5/1998	Ito		2002/0193748 A1	12/2002	Cocker et al.	
5,984,899 A	11/1999	D'Alessio et al.		2003/0093009 A1 *	5/2003	Newby et al. ....	600/576
D422,700 S	4/2000	Crawford et al.		2004/0010228 A1 *	1/2004	Swenson et al. ....	604/110
6,149,629 A	11/2000	Wilson et al.		2004/0059302 A1	3/2004	Crawford et al.	
D436,169 S *	1/2001	Wilkinson et al. ....	D24/130	2004/0092872 A1	5/2004	Botich et al.	
D439,975 S *	4/2001	Wilkinson et al. ....	D24/130	2004/0111057 A1 *	6/2004	Wilkinson .....	604/110
D440,657 S *	4/2001	Wilkinson et al. ....	D24/130	2004/0193120 A1 *	9/2004	Ferguson et al. ....	604/263
D442,280 S	5/2001	Crawford et al.		2004/0210197 A1 *	10/2004	Conway .....	604/198
D445,183 S *	7/2001	McWethy et al. ....	D24/130	2005/0004524 A1	1/2005	Newby et al.	
6,261,263 B1	7/2001	Huet et al.		2005/0187493 A1	8/2005	Swenson et al.	
6,298,541 B1	10/2001	Newby et al.		2005/0215951 A1 *	9/2005	Saulenas et al. ....	604/110
D450,834 S *	11/2001	Newby et al. ....	D24/112	2006/0036219 A1	2/2006	Alvin	
D460,180 S *	7/2002	Swenson .....	D24/130	2007/0167914 A1	7/2007	Leong et al.	
D460,183 S *	7/2002	Wilkinson et al. ....	D24/130	2007/0179451 A1 *	8/2007	Sprinkle et al. ....	604/192
D461,245 S *	8/2002	Niermann .....	D24/130	2007/0282275 A1 *	12/2007	Ferguson et al. ....	604/198
6,436,086 B1	8/2002	Newby et al.					
6,440,104 B1	8/2002	Newby et al.					
6,524,276 B1 *	2/2003	Halseth et al. ....	604/110				
6,533,760 B2	3/2003	Leong					
6,592,556 B1	7/2003	Thorne					
6,623,456 B1	9/2003	Holdaway et al.					
6,635,032 B2	10/2003	Ward, Jr.					
6,648,855 B2	11/2003	Crawford et al.					
D484,976 S *	1/2004	Wilkinson .....	D24/130				

OTHER PUBLICATIONS

U.S. Appl. No. 12/044,469; filed Mar. 7, 2008; Crawford.  
 U.S. Appl. No. 12/206,273; filed Sep. 8, 2008; Tan.  
 U.S. Appl. No. 12/206,299; filed Sep. 8, 2008; Crawford.  
 U.S. Appl. No. 29/304,786; filed Mar. 7, 2008; Crawford.  
 U.S. Appl. No. 29/304,794; filed Mar. 7, 2008; Crawford.  
 U.S. Appl. No. 29/304,801; filed Mar. 7, 2008; Crawford.  
 U.S. Appl. No. 29/304,807; filed Mar. 7, 2008; Crawford.

\* cited by examiner



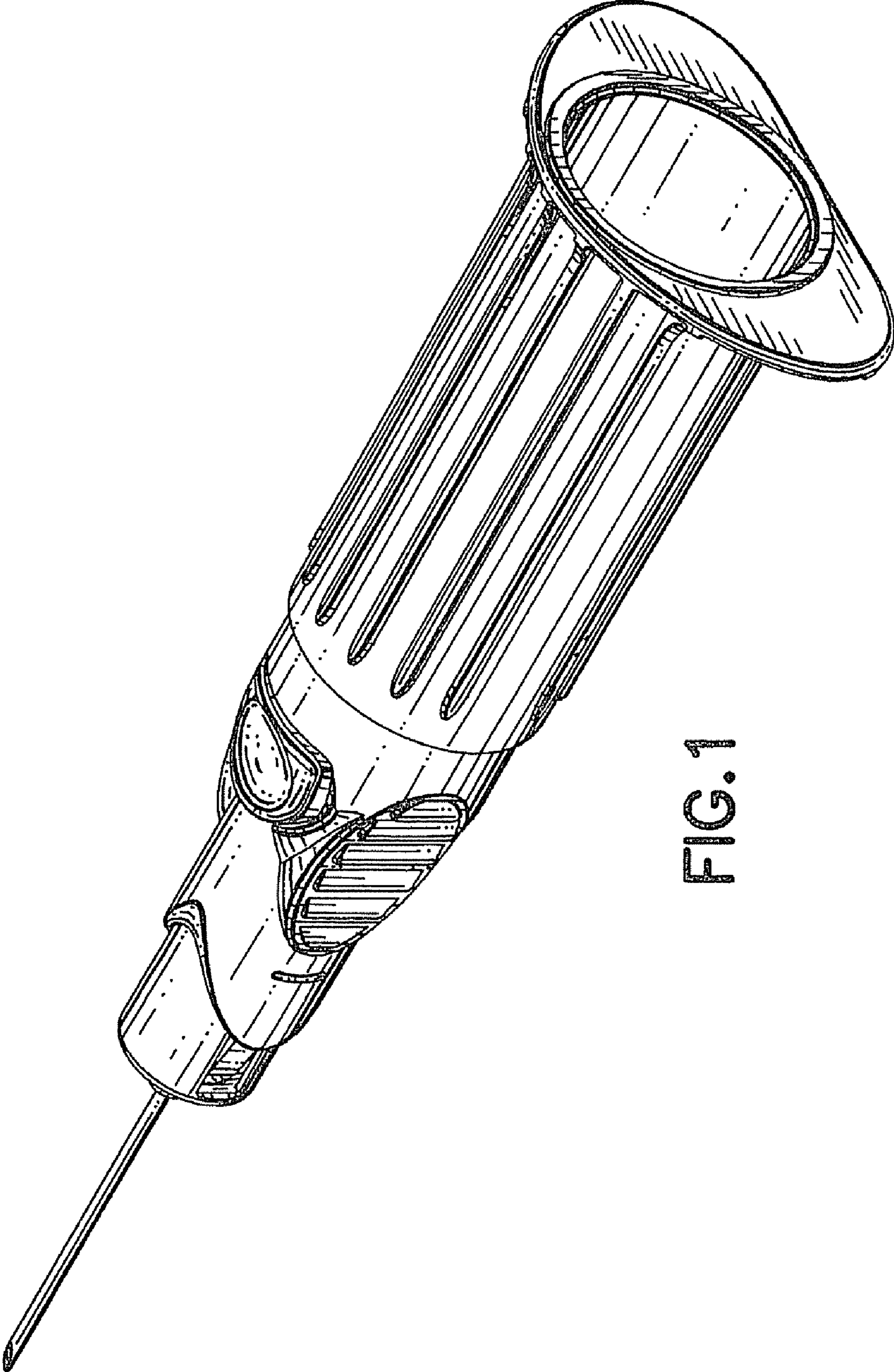

FIG. 1

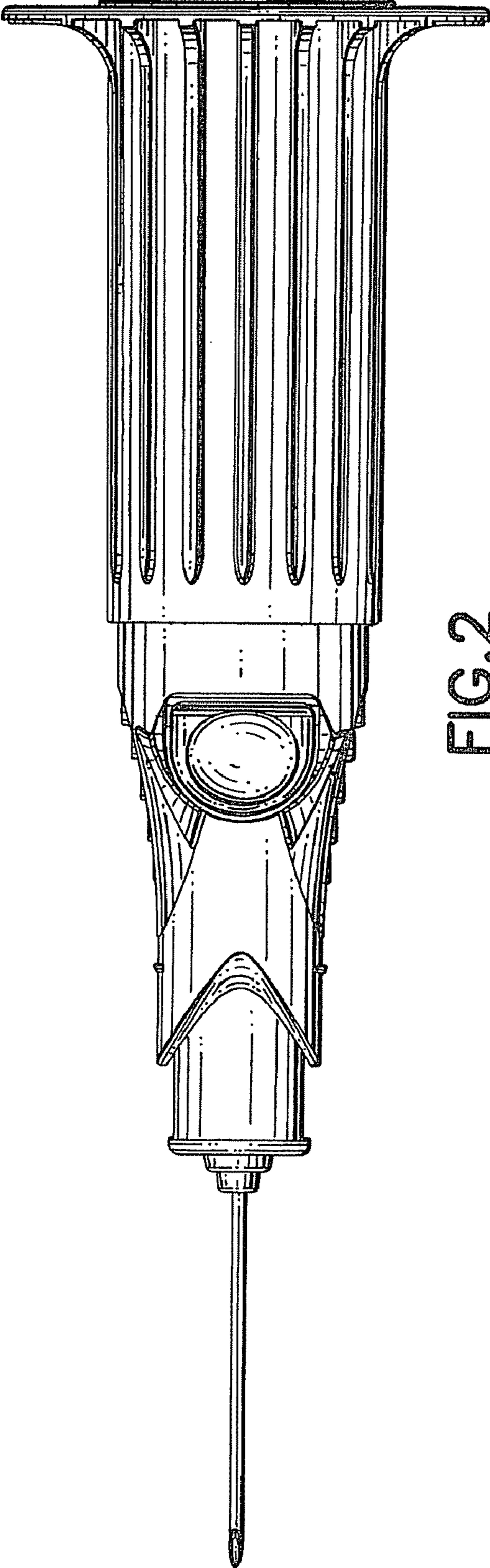

FIG. 2

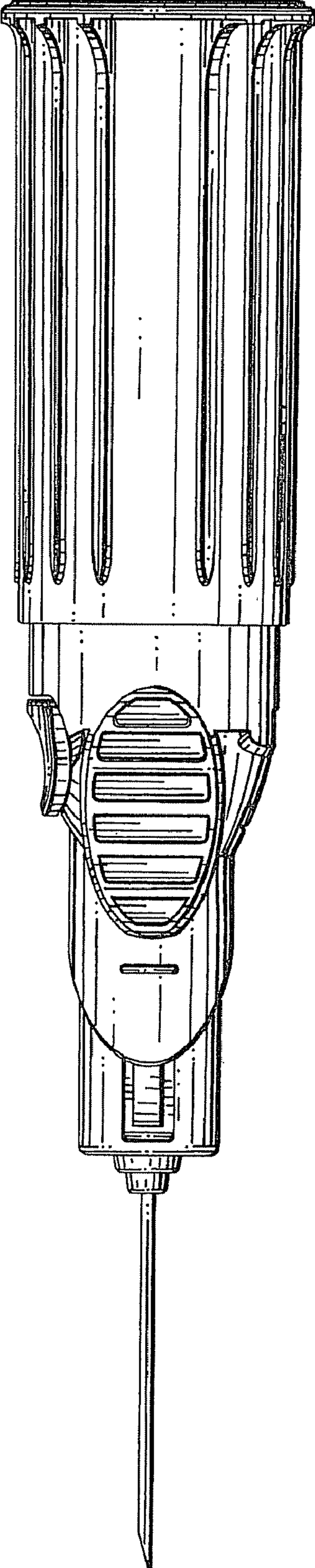

FIG. 3

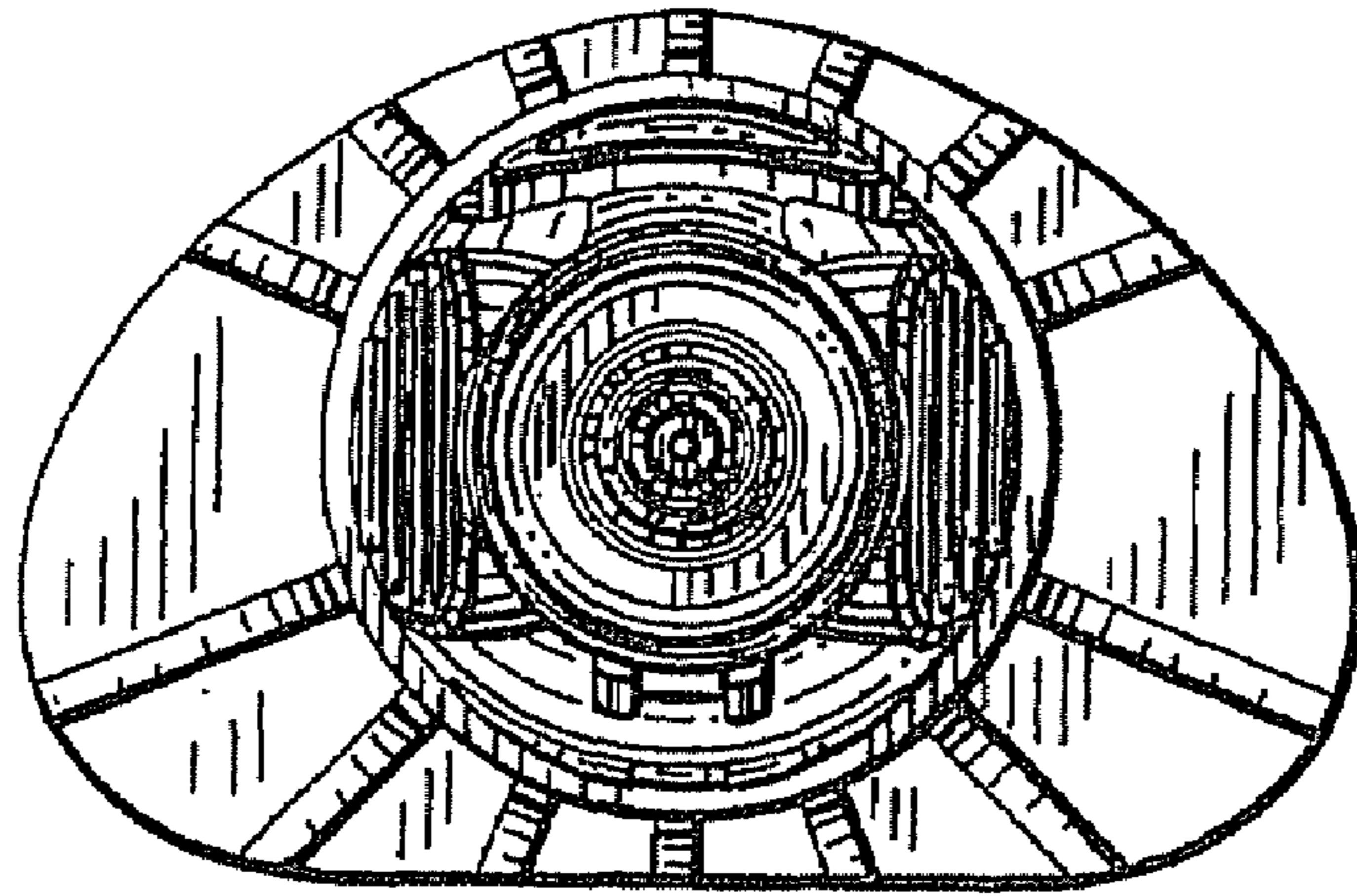

FIG. 4

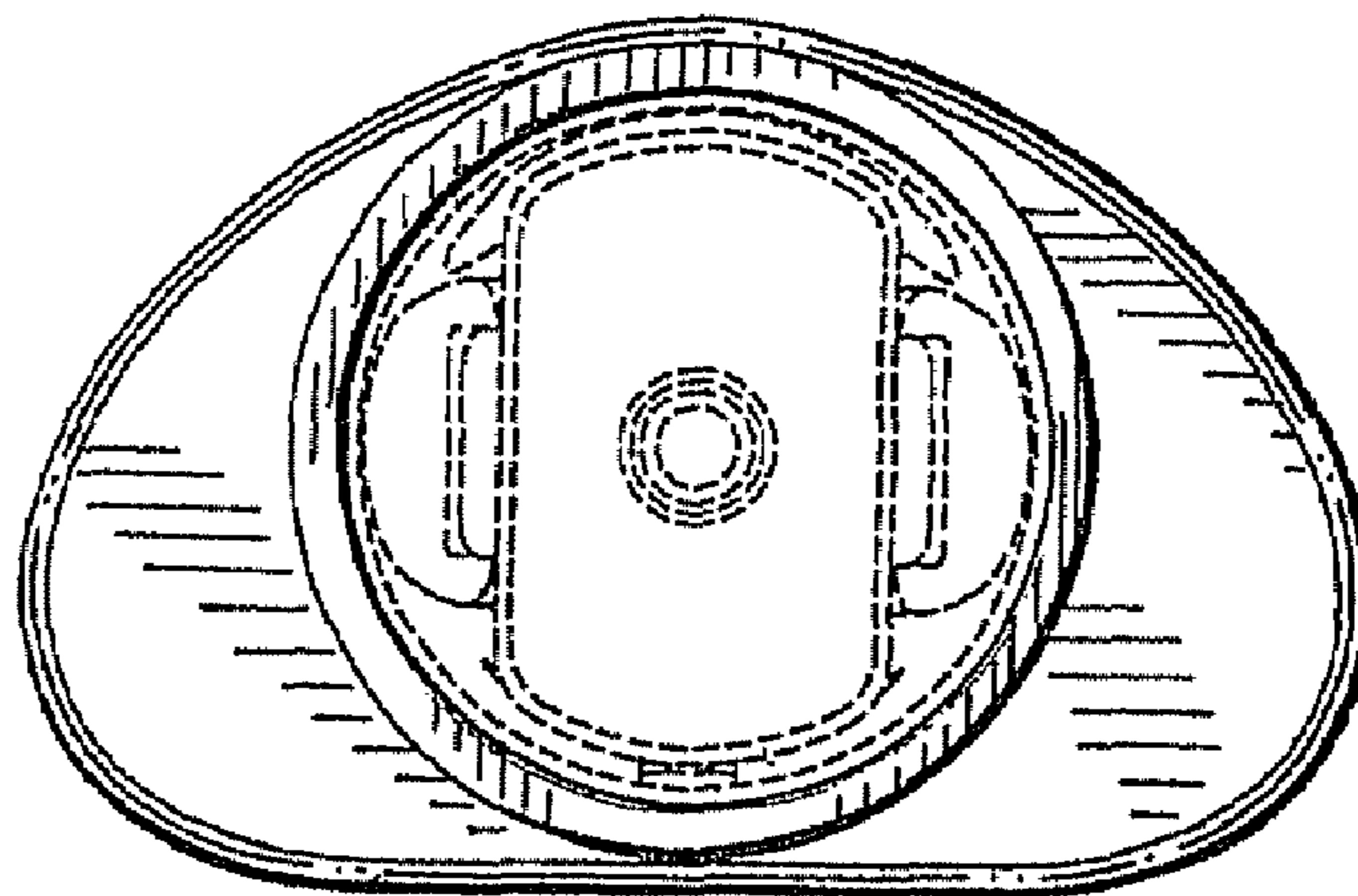

FIG. 5



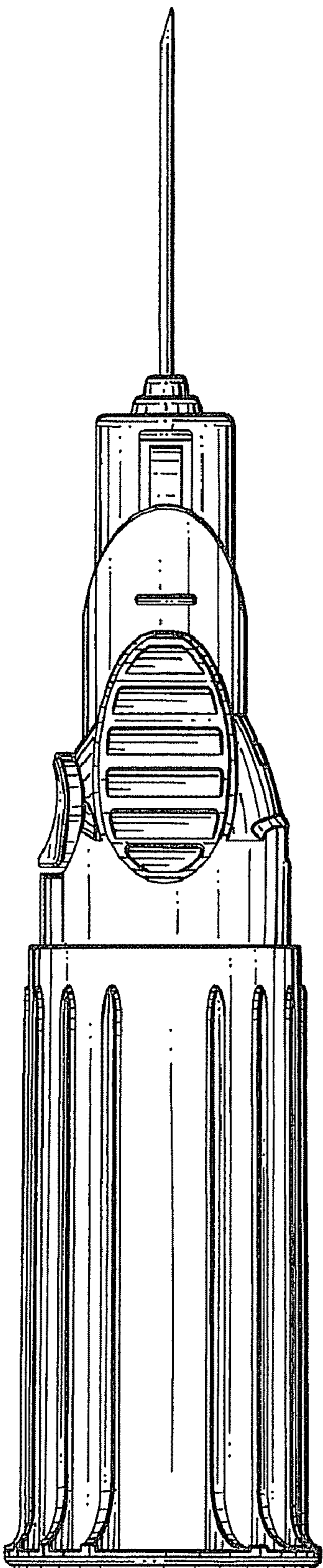

FIG. 6

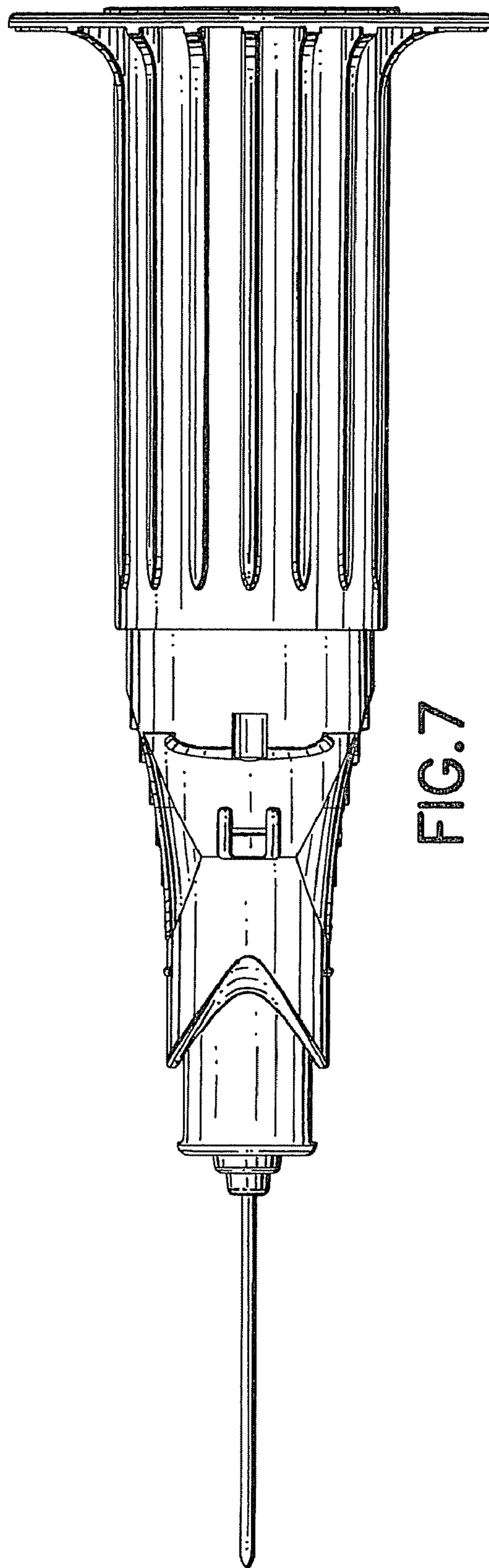

FIG. 7

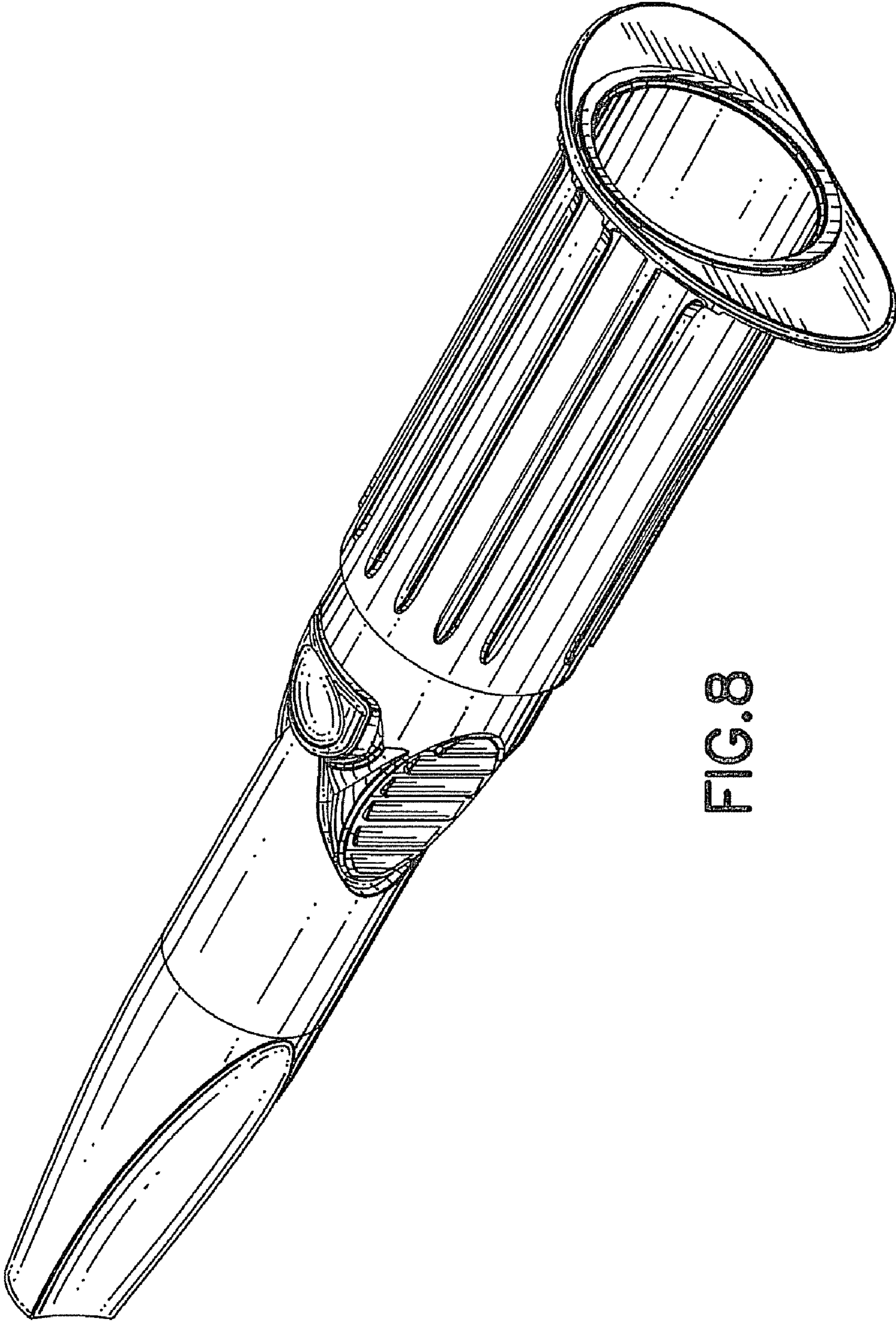
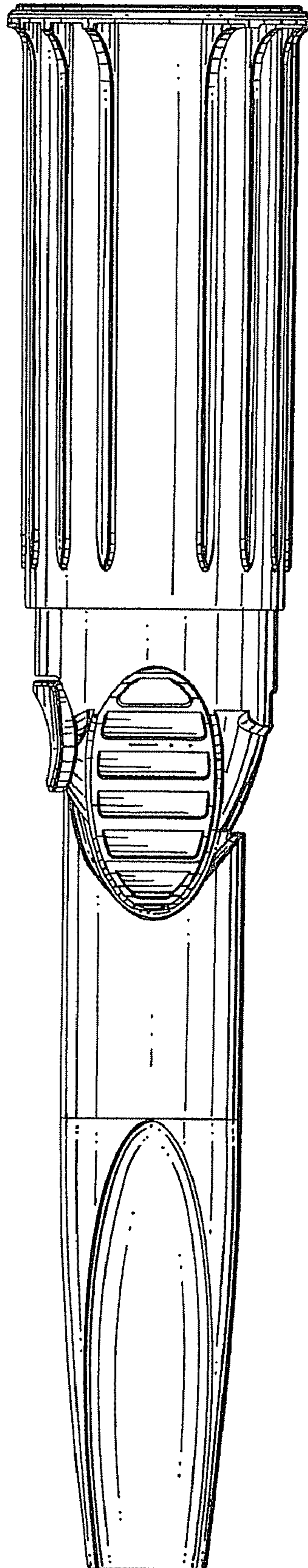
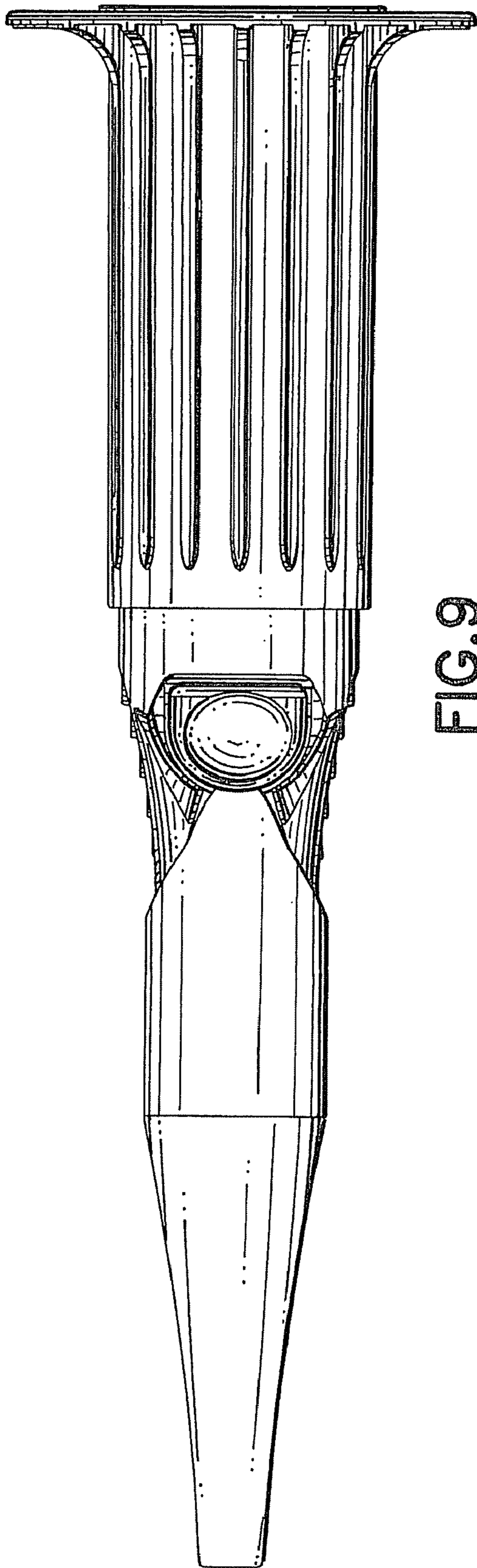

FIG. 8







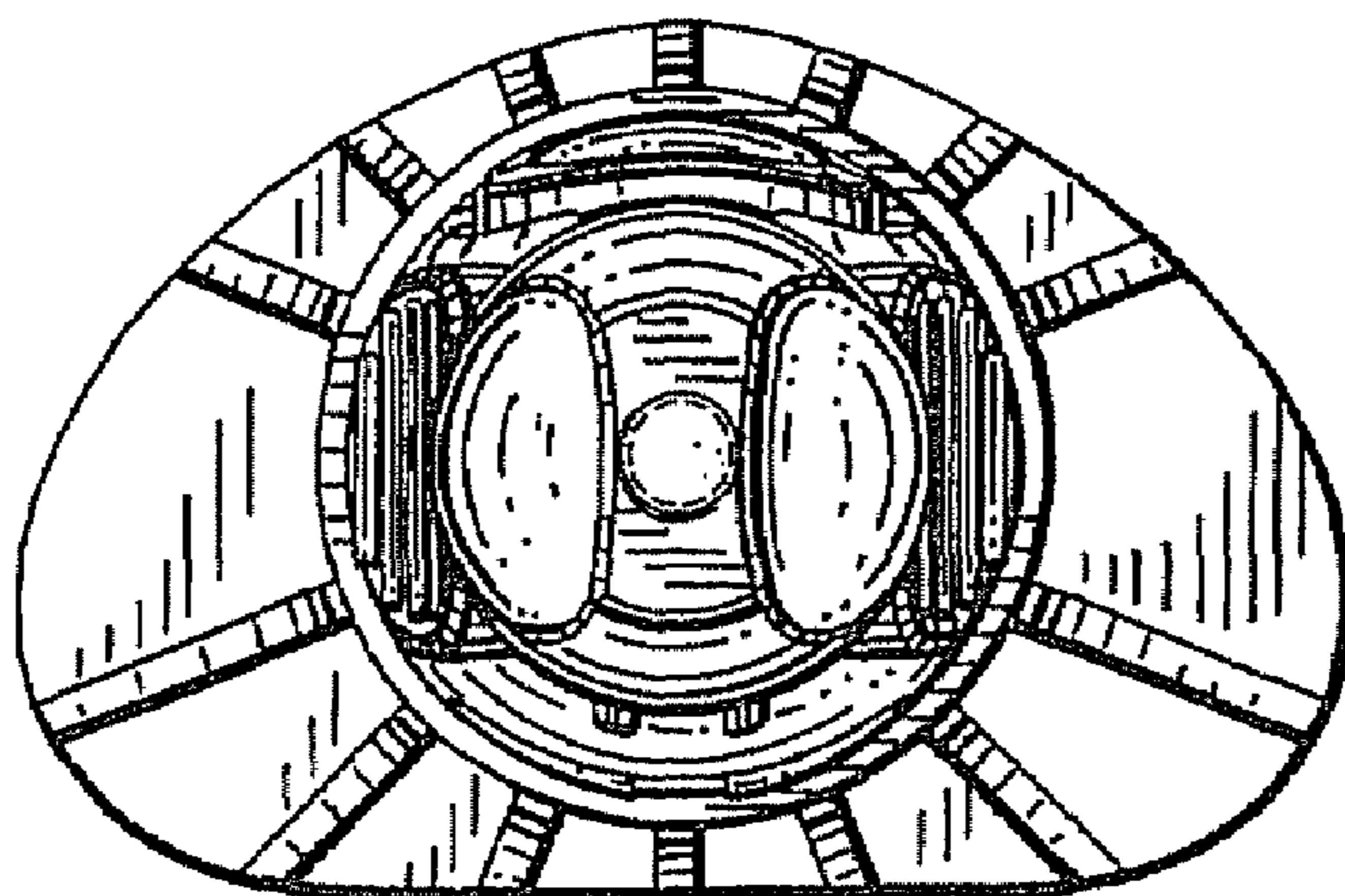

FIG. 11

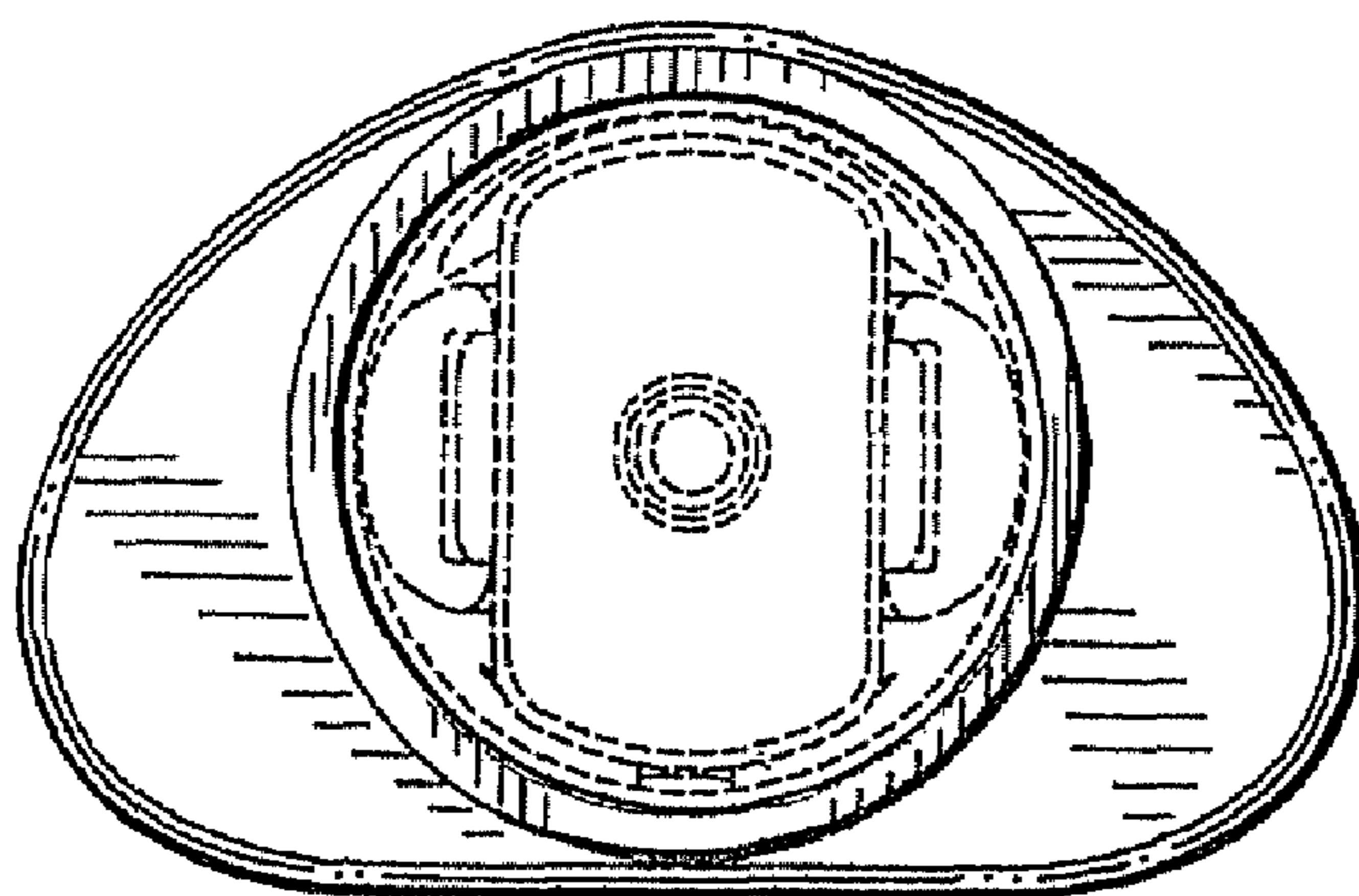

FIG. 12

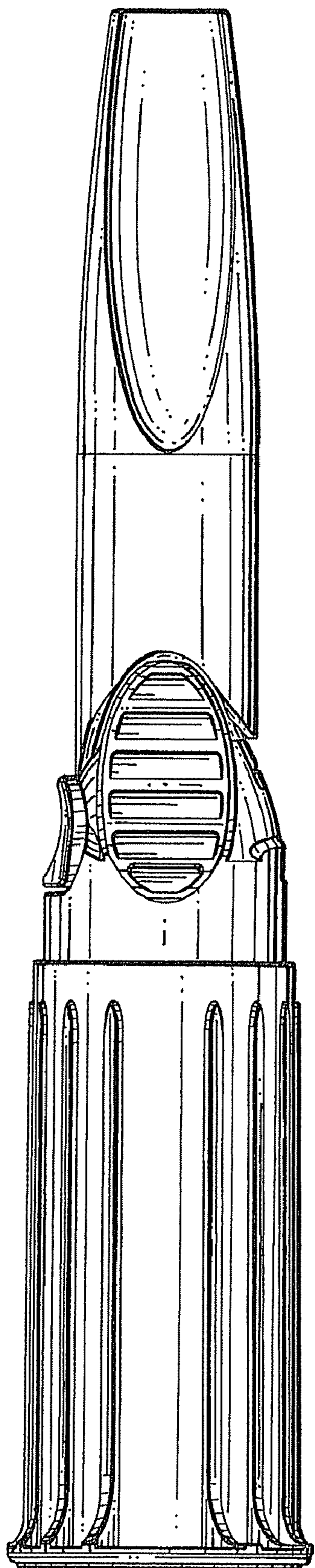

FIG. 13

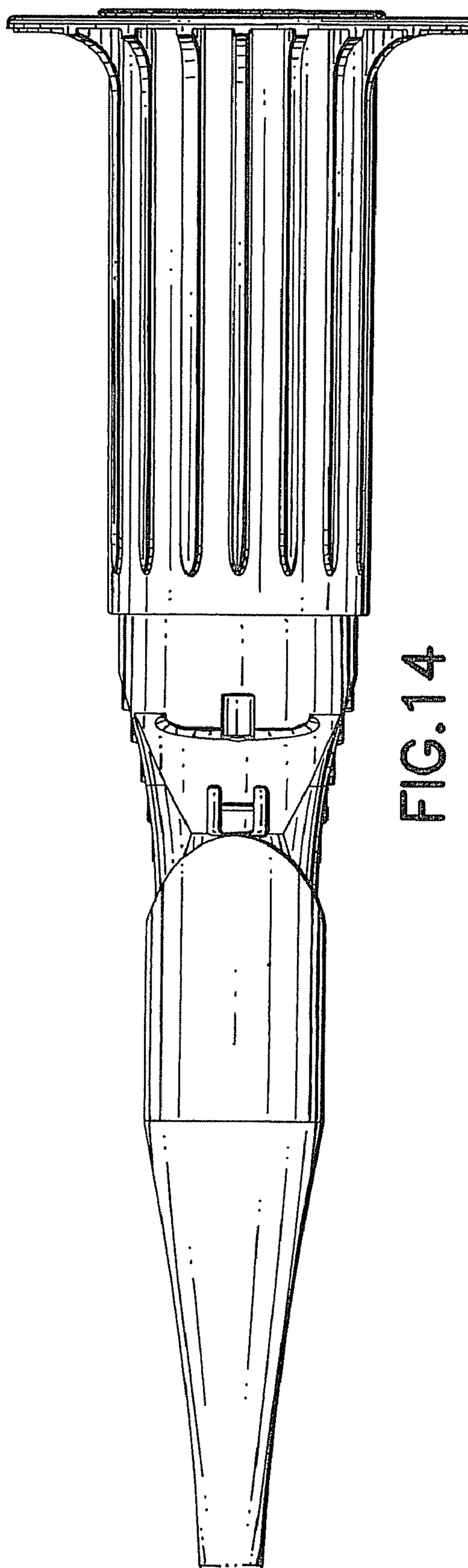

FIG. 14