



US00D605253S

(12) **United States Design Patent**
Lai

(10) **Patent No.:** **US D605,253 S**

(45) **Date of Patent:** **** Dec. 1, 2009**

(54) **SWITCH VALVE**

(76) **Inventor:** **Hung-Lin Lai**, 5-3, Chien Pan Lane,
Kou Chien Li, Lu Kang Township,
Chang Hua Hsien (TW)

(**) **Term:** **14 Years**

(21) **Appl. No.:** **29/306,982**

(22) **Filed:** **Apr. 21, 2008**

(51) **LOC (9) Cl.** **23-01**

(52) **U.S. Cl.** **D23/233**

(58) **Field of Classification Search** D23/233–237,
D23/244–249; 137/309–311, 246, 222, 538,
137/597, 625.11, 625.46, 625.64, 625.65,
137/460, 498, 870, 881, 883; 251/174, 297,
251/304; 62/324.1, 324.6

See application file for complete search history.

(56) **References Cited**

U.S. PATENT DOCUMENTS

D27,244	S	*	6/1897	Ford	D23/237
D300,171	S	*	3/1989	Been	D23/233
D351,897	S	*	10/1994	Keeslar	D23/233
5,992,823	A		11/1999	Lai		
D448,454	S	*	9/2001	Lai	D23/245
D470,222	S	*	2/2003	Nortier	D23/233
D473,631	S	*	4/2003	Lai	D23/245

6,640,390	B1		11/2003	Lai		
D495,031	S	*	8/2004	Taylor	D23/233
D498,821	S	*	11/2004	Nortier	D23/249
7,124,999	B1	*	10/2006	Lai	251/288
D568,965	S	*	5/2008	Johnson	D23/233

* cited by examiner

Primary Examiner—Cathron C. Brooks

Assistant Examiner—Maurice Stevens

(74) *Attorney, Agent, or Firm*—Alan Kamrath; Kamrath & Associates PA

(57) **CLAIM**

The ornamental design for a switch valve, as shown and described.

DESCRIPTION

FIG. 1 is a perspective view of a switch valve showing my design;

FIG. 2 is a front elevational view thereof;

FIG. 3 is a rear elevational view thereof;

FIG. 4 is a left side elevational view thereof;

FIG. 5 is a right side elevational view thereof;

FIG. 6 is a top plan view thereof; and,

FIG. 7 is a bottom plan view thereof.

1 Claim, 4 Drawing Sheets

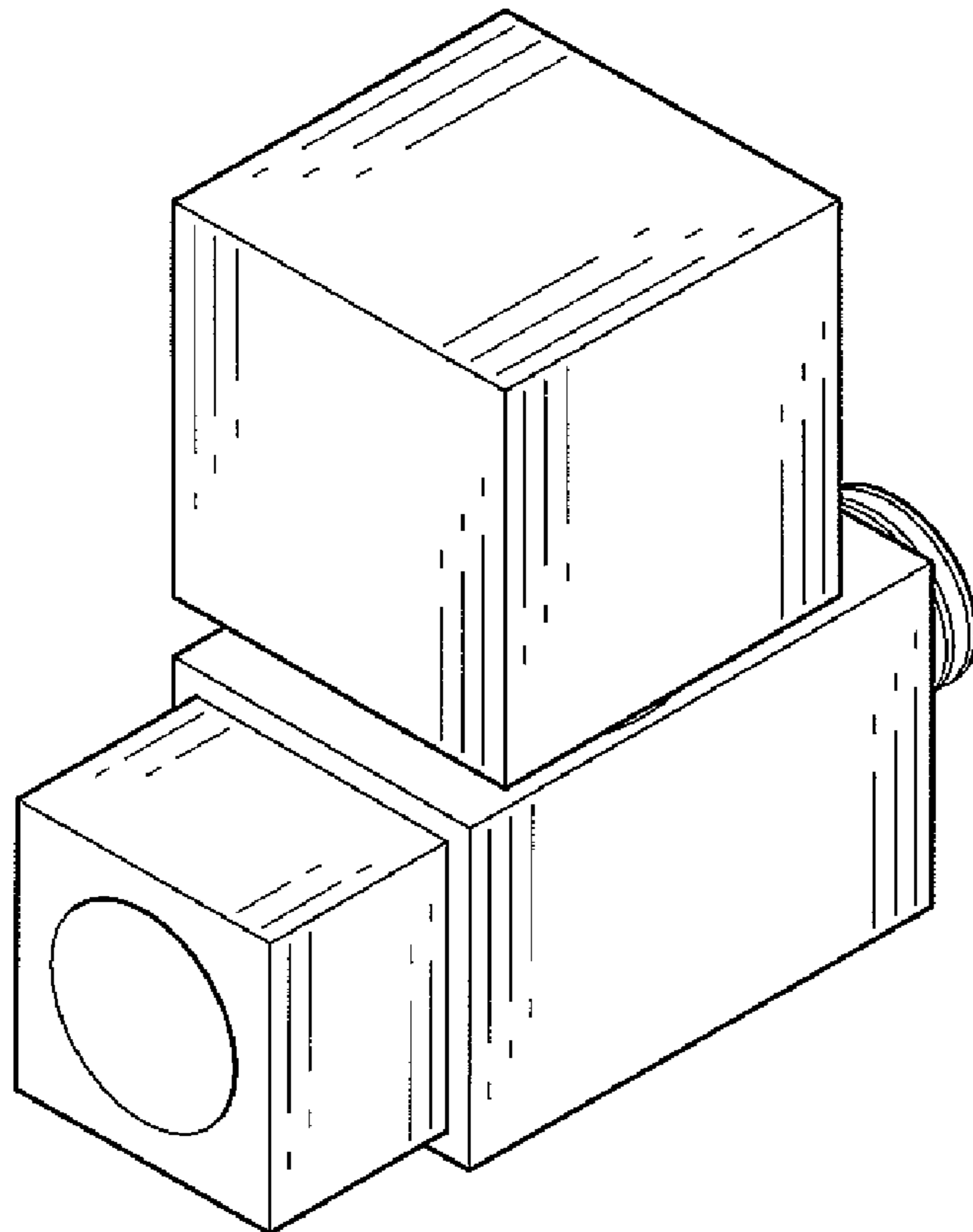

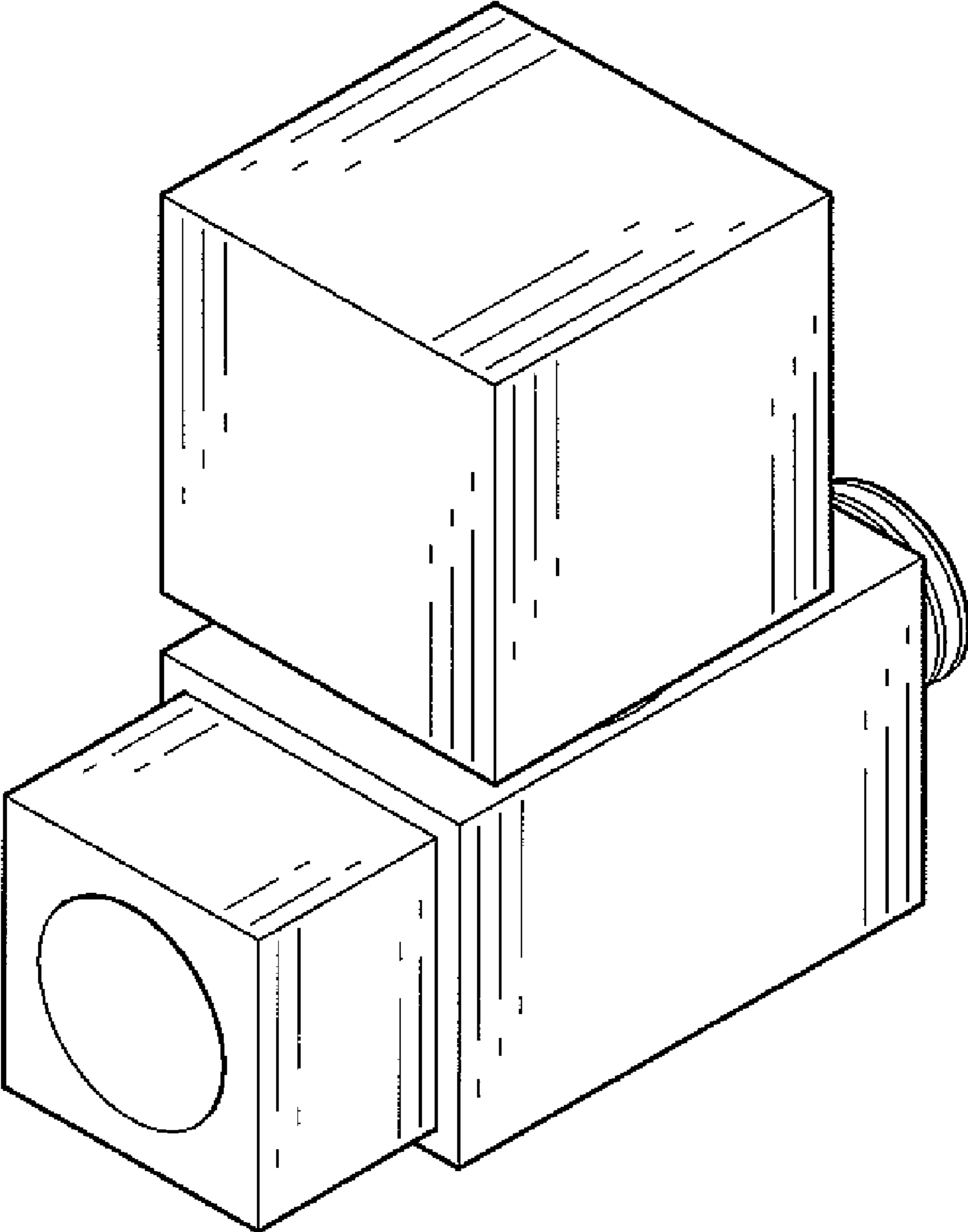

FIG. 1

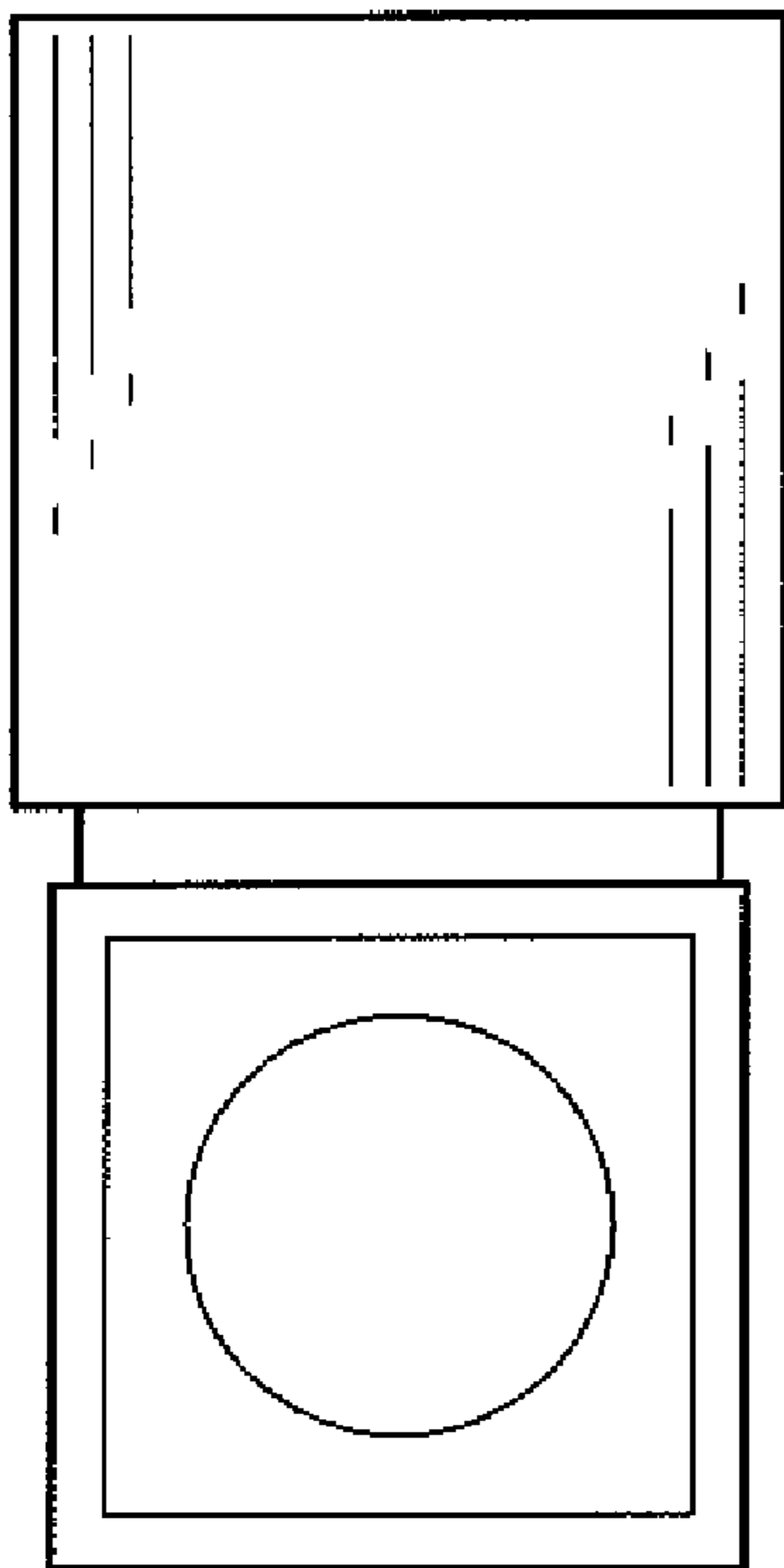

FIG. 2

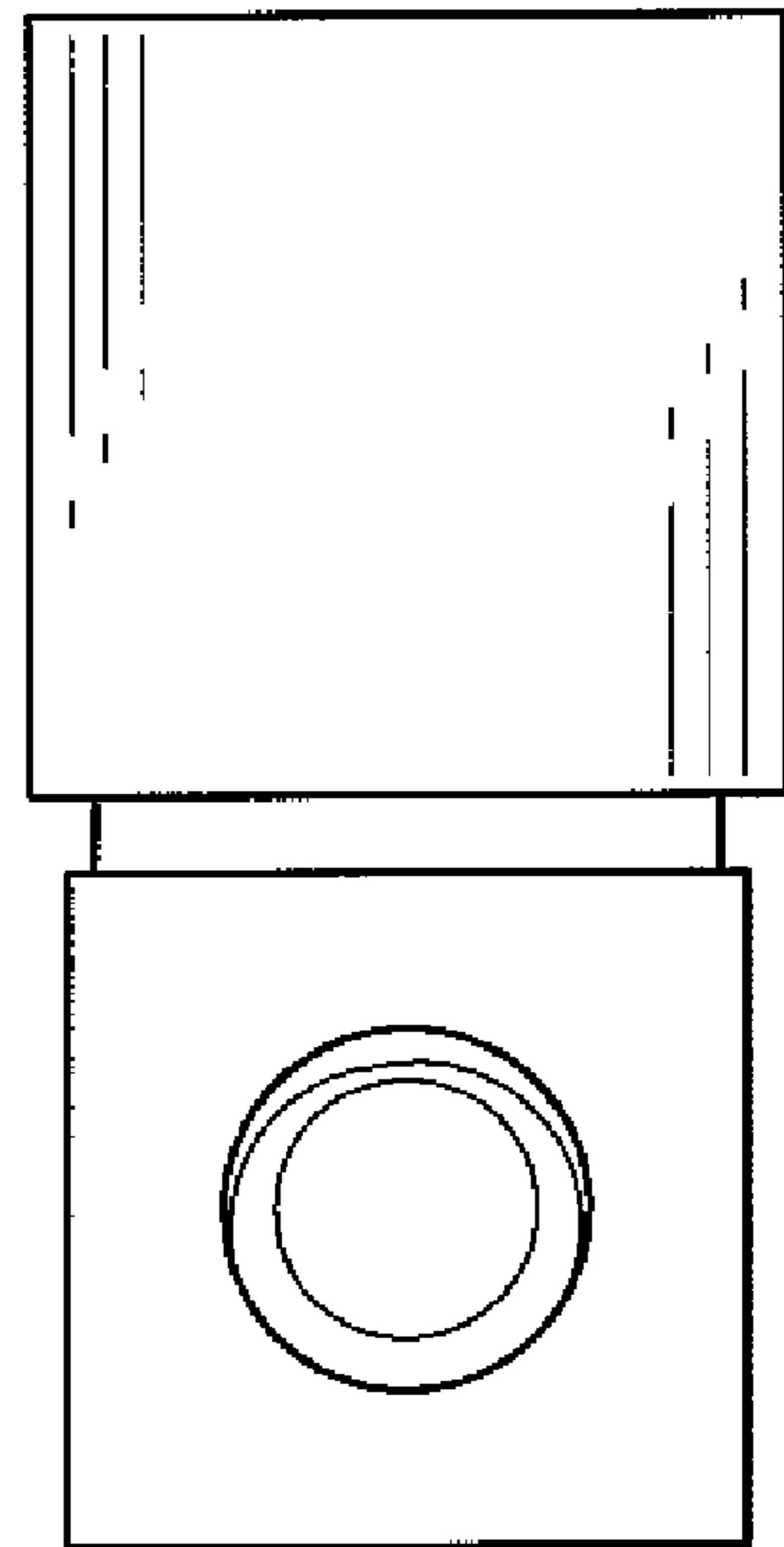

FIG. 3

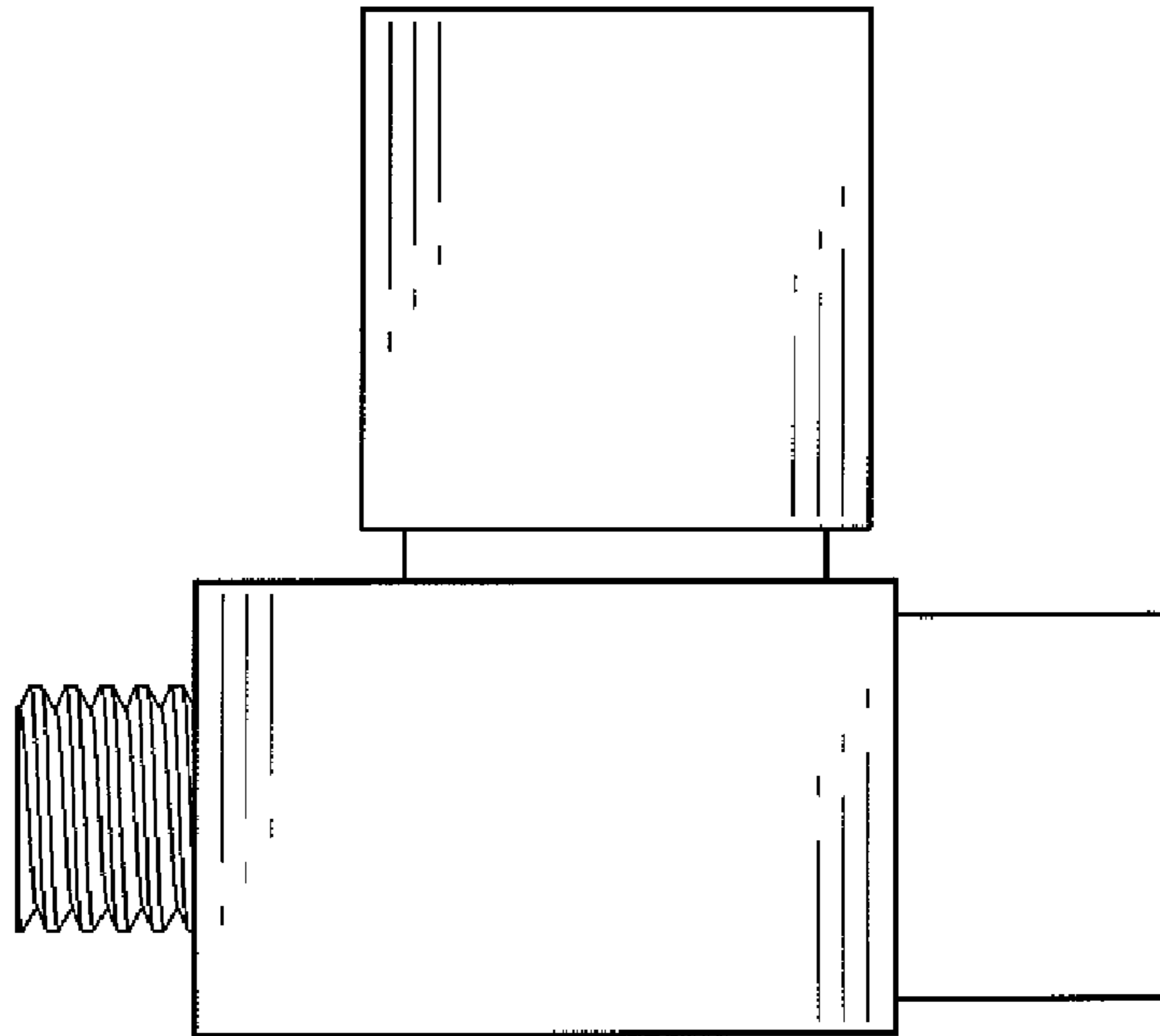

FIG. 4

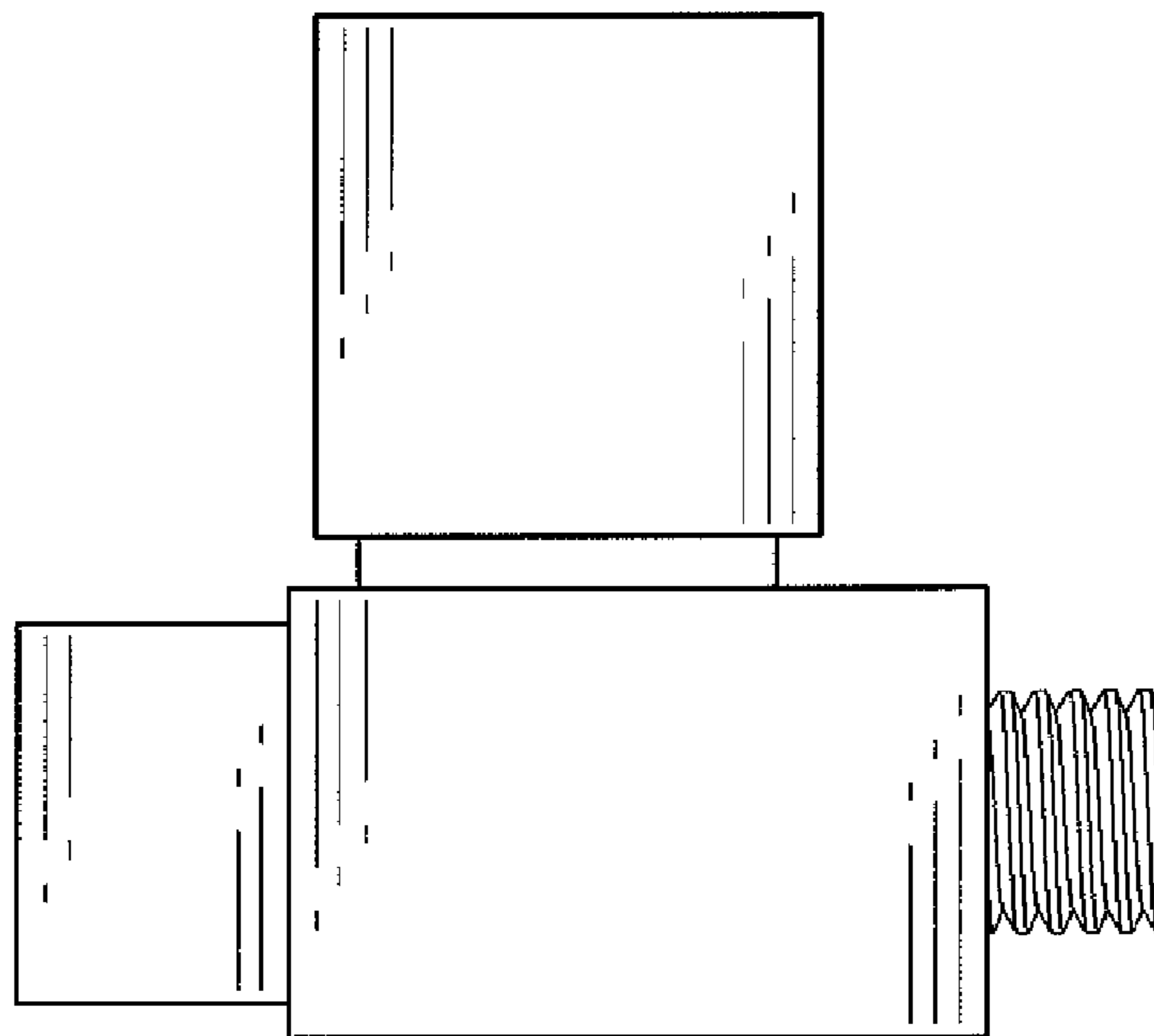

FIG. 5

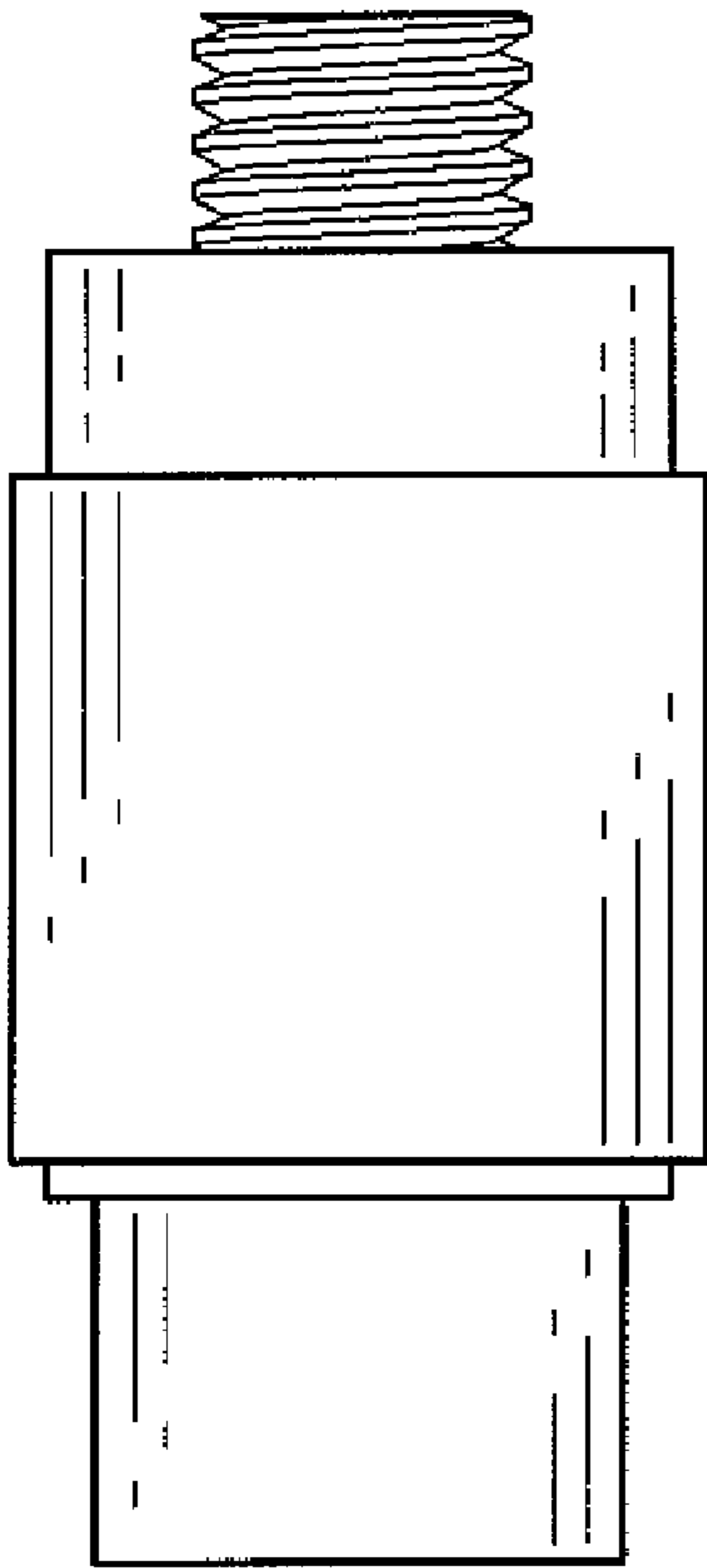

FIG. 6

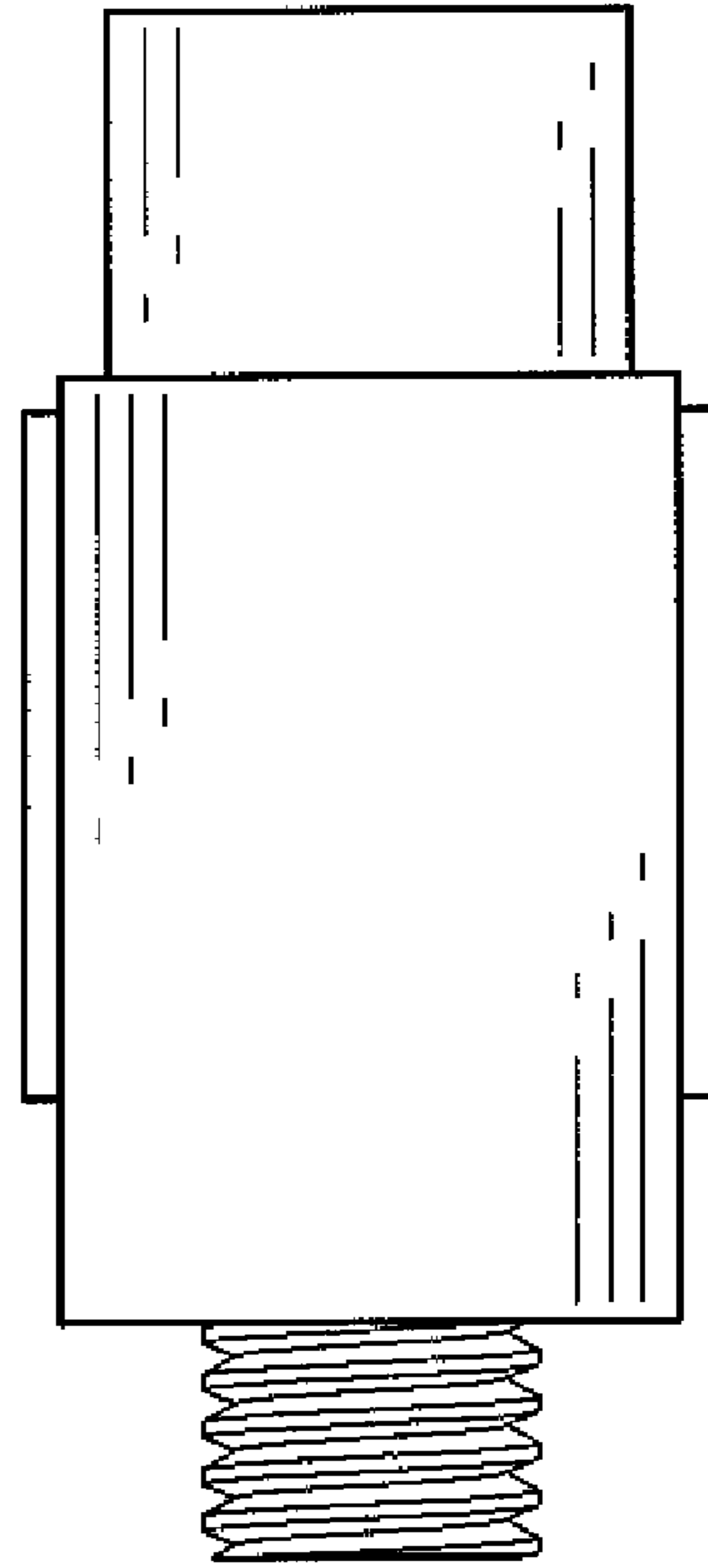

FIG. 7