



US00D605183S

(12) **United States Design Patent**  
**Fleischer et al.**

(10) **Patent No.:** **US D605,183 S**

(45) **Date of Patent:** **\*\* Dec. 1, 2009**

(54) **MICROPHONE**

(75) Inventors: **Dieter Fleischer**, Hannover (DE);  
**Michael Nickel**, Wedemark (DE);  
**Guenter Rosen**, Wedemark (DE)

(73) Assignee: **Sennheiser electronic GmbH & Co.**  
**KG**, Wedemark (DE)

(\*\*) Term: **14 Years**

(21) Appl. No.: **29/307,566**

(22) Filed: **Apr. 28, 2008**

(30) **Foreign Application Priority Data**

Nov. 2, 2007 (DE) ..... 407 05 540

(51) **LOC (9) Cl.** ..... **14-01**

(52) **U.S. Cl.** ..... **D14/227**

(58) **Field of Classification Search** ..... D14/225,  
D14/226, 227, 228, 229, 142, 155, 172, 214,  
D14/299; D16/221, 213, 214; D8/396; 248/74.1,  
248/74.3, 562; 181/158, 242; 381/26, 181,  
381/355, 356, 357, 358, 359, 360, 361, 362,  
381/363, 364, 365, 366, 368; D24/172  
See application file for complete search history.

(56) **References Cited**

**U.S. PATENT DOCUMENTS**

2,910,539 A \* 10/1959 Hartsfield ..... 381/174  
D189,720 S \* 2/1961 Burroughs ..... D14/228  
2,984,713 A \* 5/1961 Swinehart ..... 381/123  
D194,151 S \* 11/1962 Deschamps ..... D14/228  
D196,919 S \* 11/1963 Deschamps ..... D14/228  
3,423,544 A \* 1/1969 Weiss ..... 381/151  
D294,860 S \* 3/1988 Hoogesteger ..... D24/172  
D296,099 S \* 6/1988 Kubota ..... D14/227  
D299,921 S \* 2/1989 Kikutani ..... D14/227  
D311,189 S \* 10/1990 Lazzeroni et al. .... D14/229  
D313,802 S \* 1/1991 Peiker ..... D14/227

5,031,872 A \* 7/1991 Vance et al. .... 248/562  
D319,874 S \* 9/1991 Hoelbl ..... D24/150  
D327,211 S \* 6/1992 Tarshis et al. .... D8/349  
5,303,304 A \* 4/1994 Lee ..... 381/26  
D387,770 S \* 12/1997 Liao ..... D14/227  
D412,705 S \* 8/1999 Laiacona et al. .... D14/172  
6,721,432 B1 \* 4/2004 Yamamoto ..... 381/355  
7,251,341 B2 \* 7/2007 Epping et al. .... 381/361

\* cited by examiner

*Primary Examiner*—Paula Greene

(74) *Attorney, Agent, or Firm*—Reed Smith LLP

(57) **CLAIM**

The ornamental design for a microphone, as shown and described.

**DESCRIPTION**

FIG. 1 is an isometric view of the microphone in accordance with the invention. The broken lines in the figure form no part of the claimed design.

FIG. 2 is a top view of the microphone in accordance with the invention.

FIG. 3 is a bottom view of the microphone in accordance with the invention. The broken lines in the figure form no part of the claimed design.

FIG. 4 is a front view of the microphone in accordance with the invention. The broken lines in the figure form no part of the claimed design.

FIG. 5 is a left side view of the microphone in accordance with the invention. The broken lines in the figure form no part of the claimed design.

FIG. 6 is a back side view of the microphone in accordance with the invention; and,

FIG. 7 is a right side view of the microphone in accordance with the invention. The broken lines in the figure form no part of the claimed design.

**1 Claim, 4 Drawing Sheets**

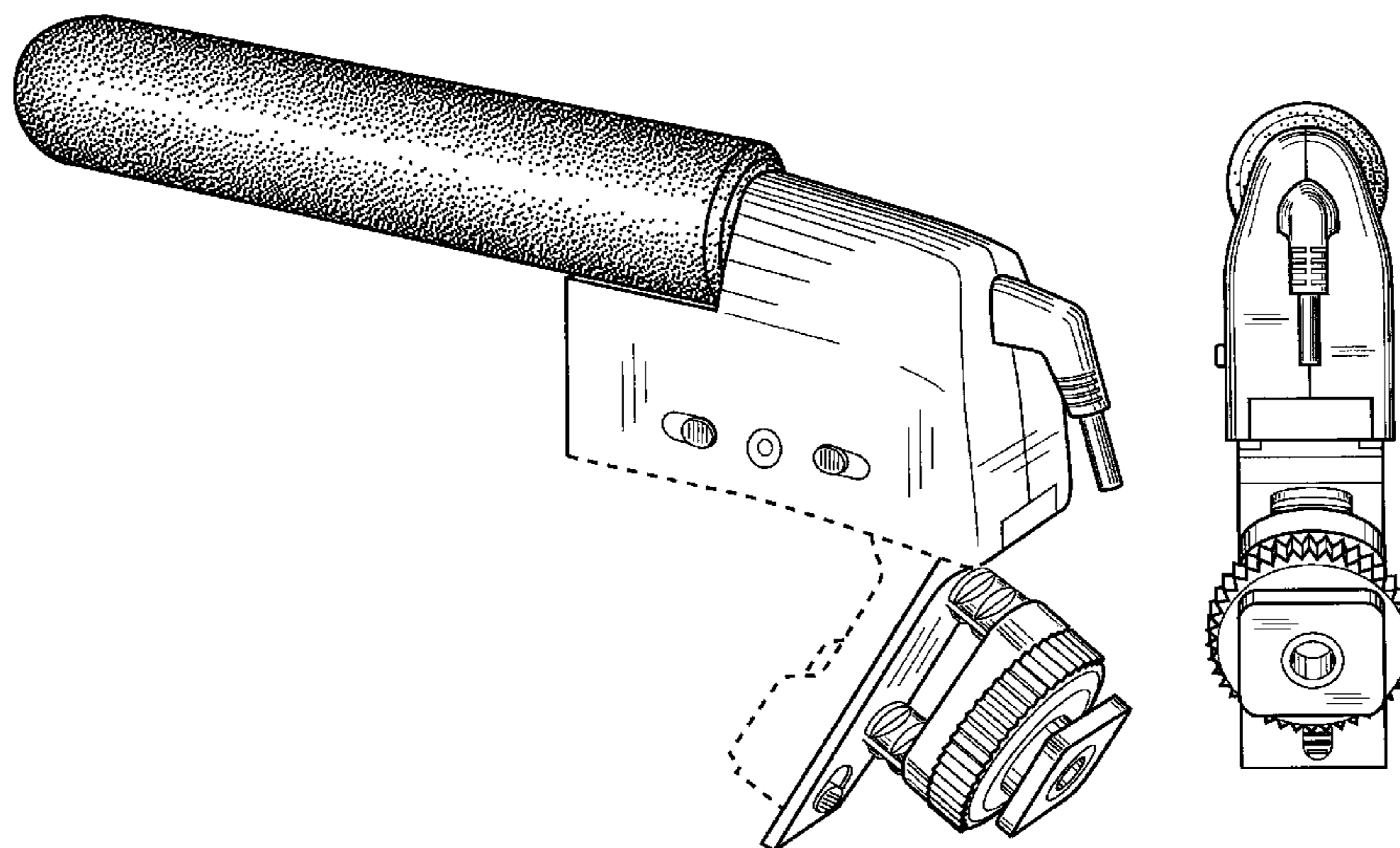
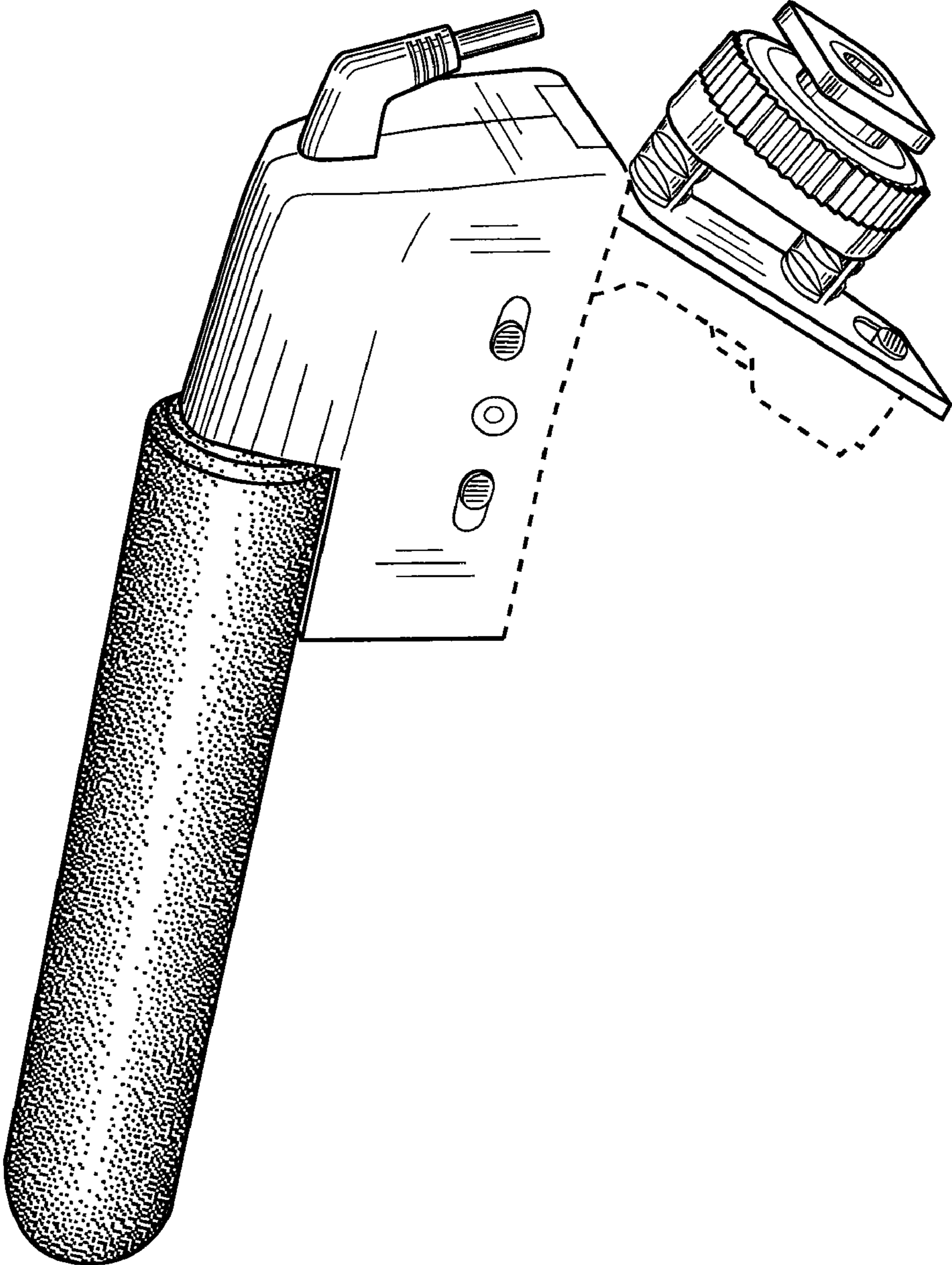
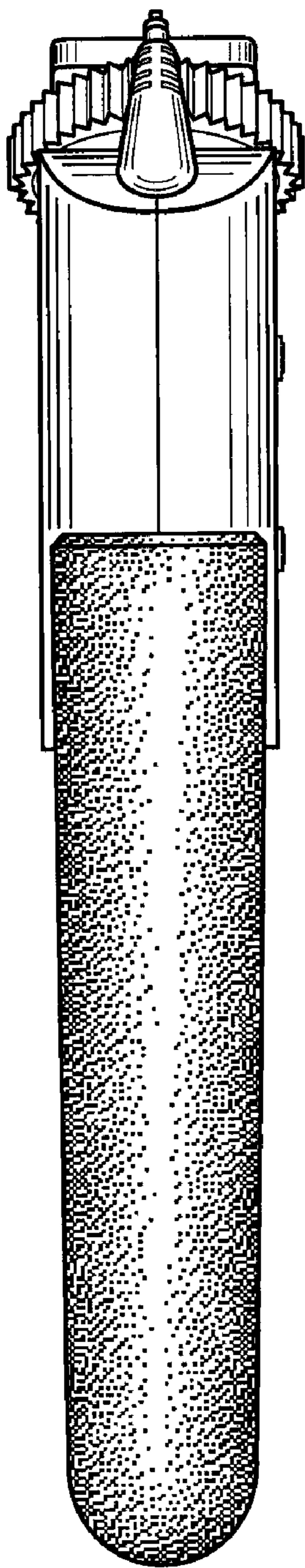
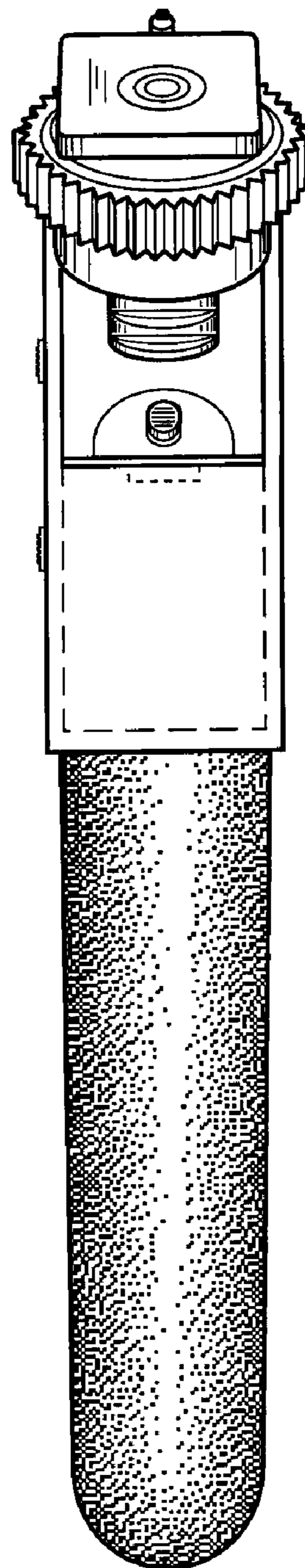

FIG. 1



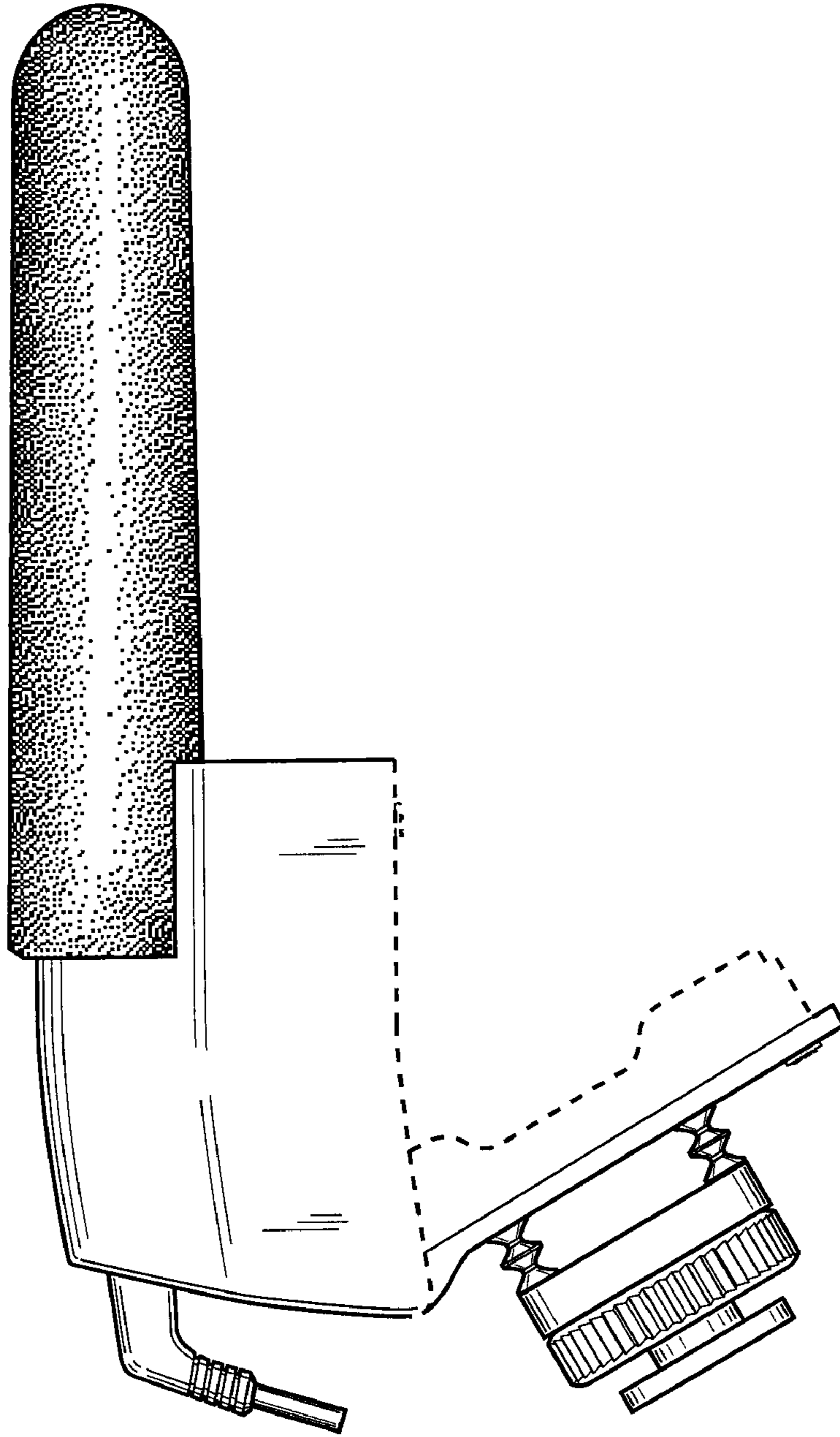

**FIG. 2**



**FIG. 3**

**FIG. 5**



**FIG. 4**

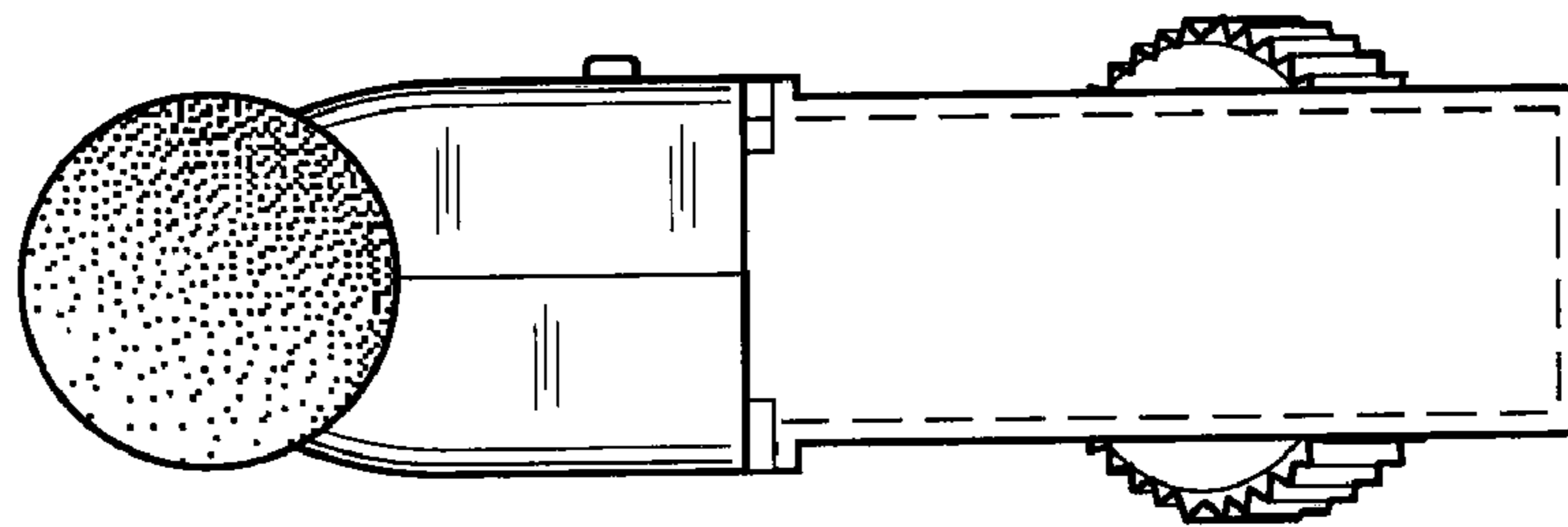

FIG. 7

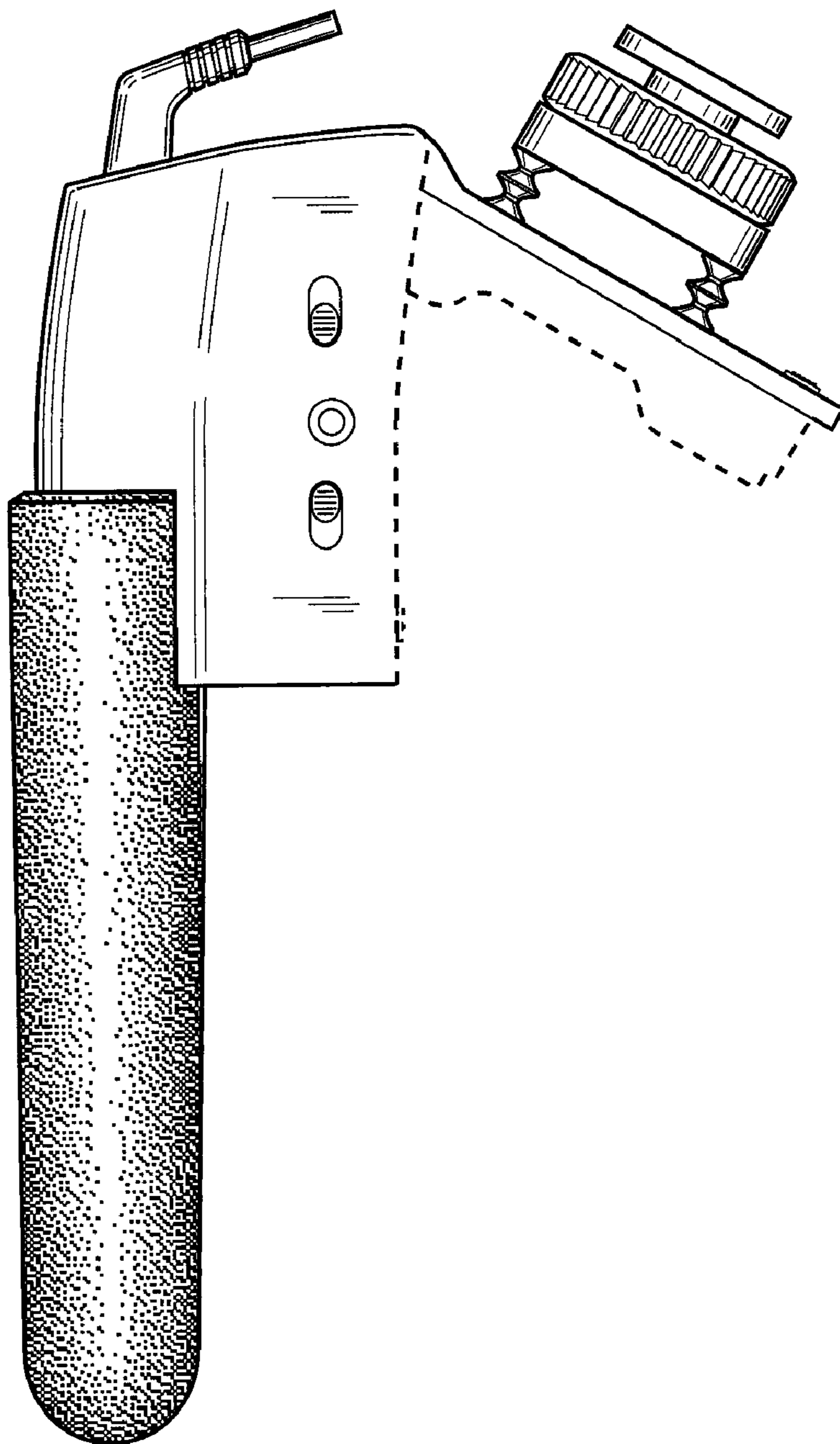

FIG. 6

