

US00D605099S

(12) **United States Design Patent**
Schmitz et al.

(10) **Patent No.:** **US D605,099 S**
(45) **Date of Patent:** **** Dec. 1, 2009**

(54) **OUTER SIDE PORTION OF A BRAKE ROTOR**

(75) Inventors: **Johann Schmitz**, Wurlingen (DE);
Ingo Hoffmann, Tuttlingen (DE);
Manfred Pallentien, Engen (DE)

(73) Assignee: **Schwabische Huttenwerke Automotive GmbH & Co. KG**, Aalen (DE)

(**) Term: **14 Years**

(21) Appl. No.: **29/306,252**

(22) Filed: **Apr. 4, 2008**

(30) **Foreign Application Priority Data**

Oct. 4, 2007 (DE) 4 07 04 958

(51) **LOC (9) Cl.** **12-16**

(52) **U.S. Cl.** **D12/180**

(58) **Field of Classification Search** D12/179-180;
188/218 XL, 264 R, 26, 73, 1, 24.22, 73.31-73.43
See application file for complete search history.

(56) **References Cited**

U.S. PATENT DOCUMENTS

D458,882 S * 6/2002 Oberti D12/180
D465,179 S * 11/2002 Ballinger D12/180
D482,643 S * 11/2003 Gavin D12/180
D484,836 S * 1/2004 Gavin D12/180
7,159,698 B2 * 1/2007 Banks et al. 188/218 XL

D565,487 S 4/2008 Zhang
2006/0086579 A1 * 4/2006 Gerber 188/218 XL
2006/0124410 A1 * 6/2006 Drage 188/218 XL
2007/0199778 A1 * 8/2007 Lee 188/218 XL
2008/0135359 A1 * 6/2008 Basirico et al. 188/218 XL
2009/0000884 A1 * 1/2009 Layton et al. 188/218 XL
2009/0020379 A1 * 1/2009 Hanna et al. 188/218 XL

* cited by examiner

Primary Examiner—Antoine D Davis

(74) *Attorney, Agent, or Firm*—GrayRobinson, PA

(57) **CLAIM**

The ornamental design of an outer side portion of a brake rotor, as shown and described.

DESCRIPTION

FIG. 1 is a first perspective view of a first embodiment thereof as viewed from a generally front-elevational perspective;

FIG. 2 is a second perspective view of the embodiment of FIG. 1 as viewed from a generally side elevational perspective;

FIG. 3 is a front-elevational view of a third embodiment thereof;

FIG. 4 is a partial perspective view of the embodiment of FIG. 3; and,

FIG. 5 is a perspective, generally front-elevational view of a fourth embodiment thereof.

1 Claim, 4 Drawing Sheets

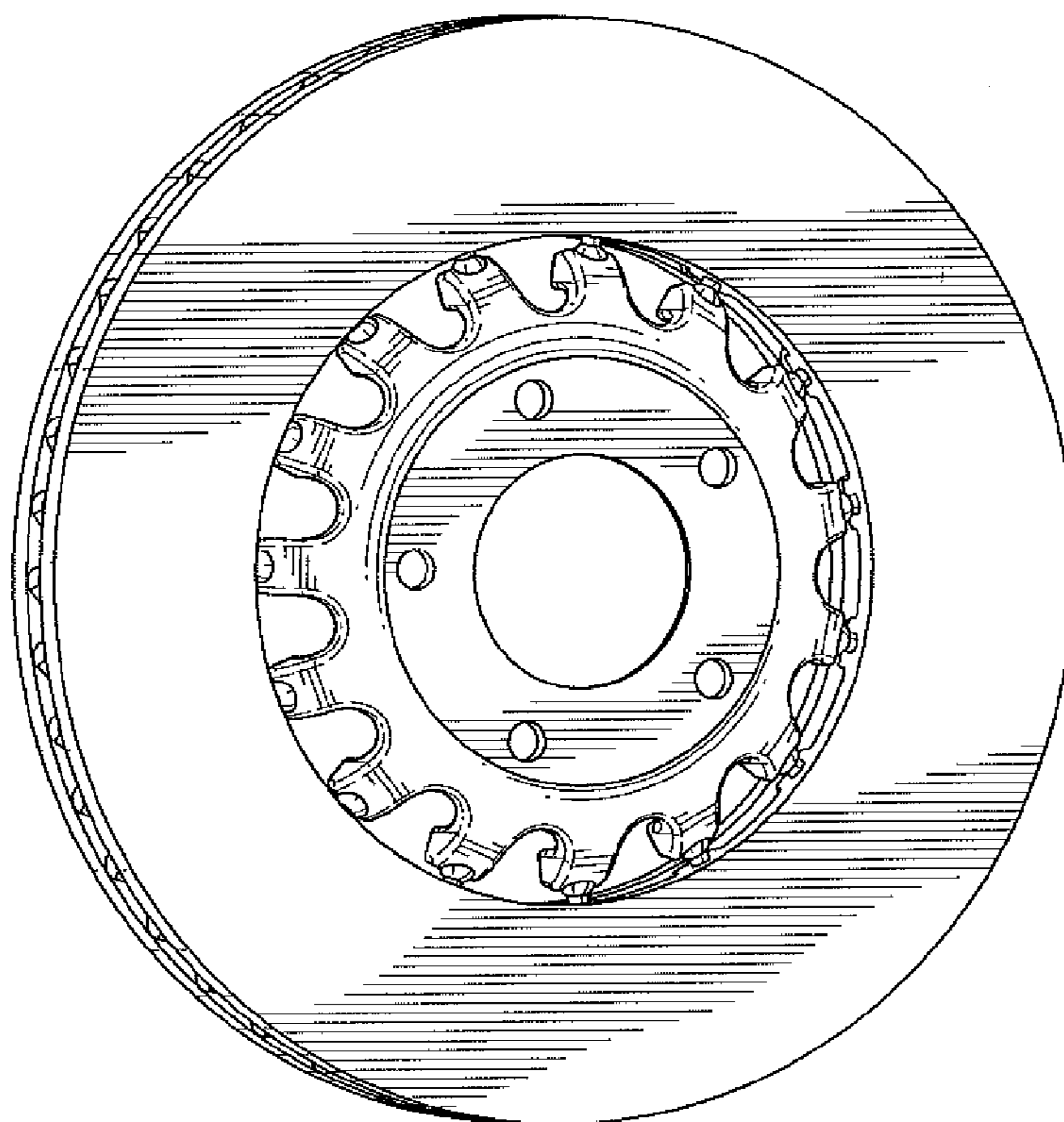

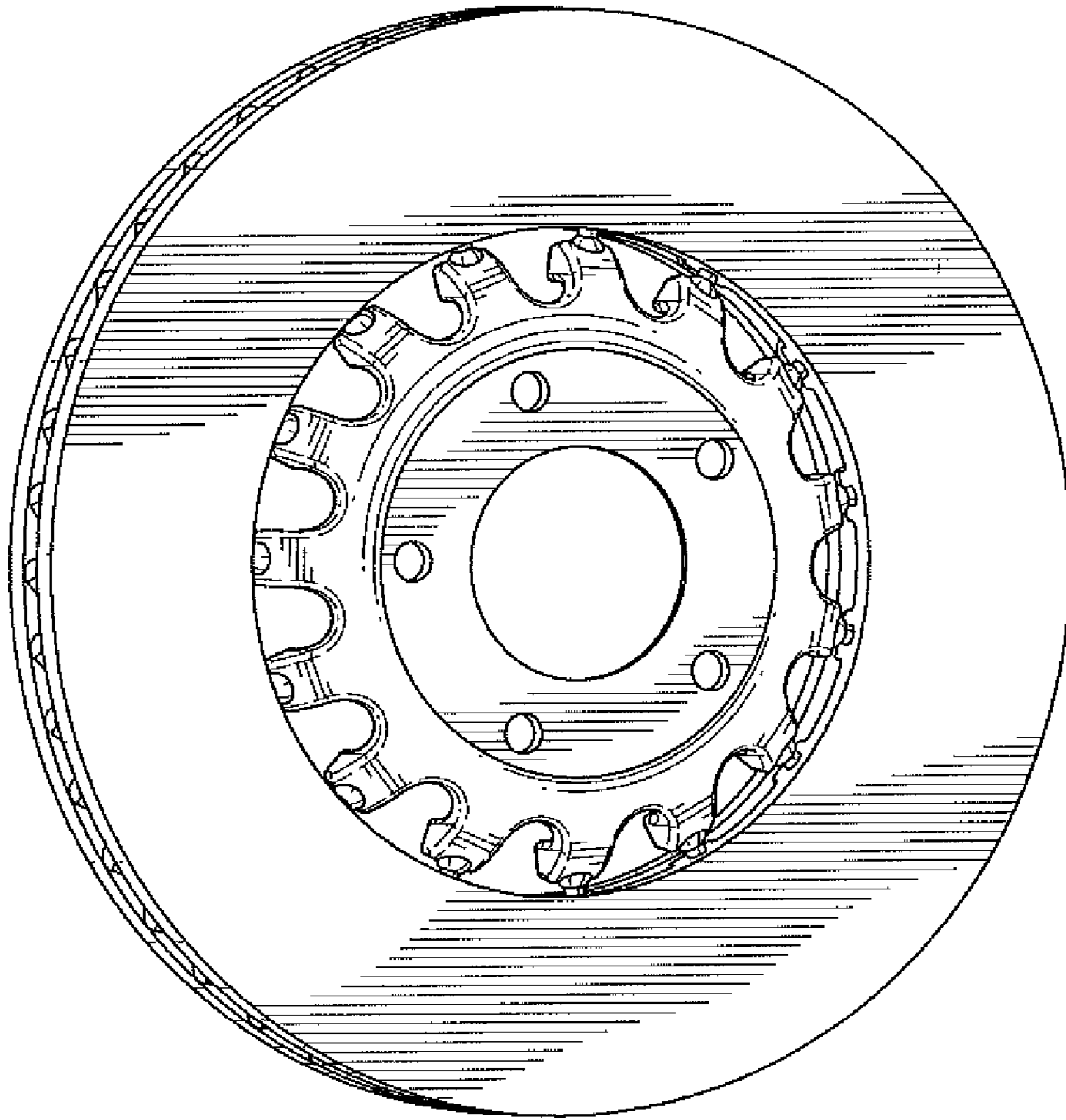

FIG. 1

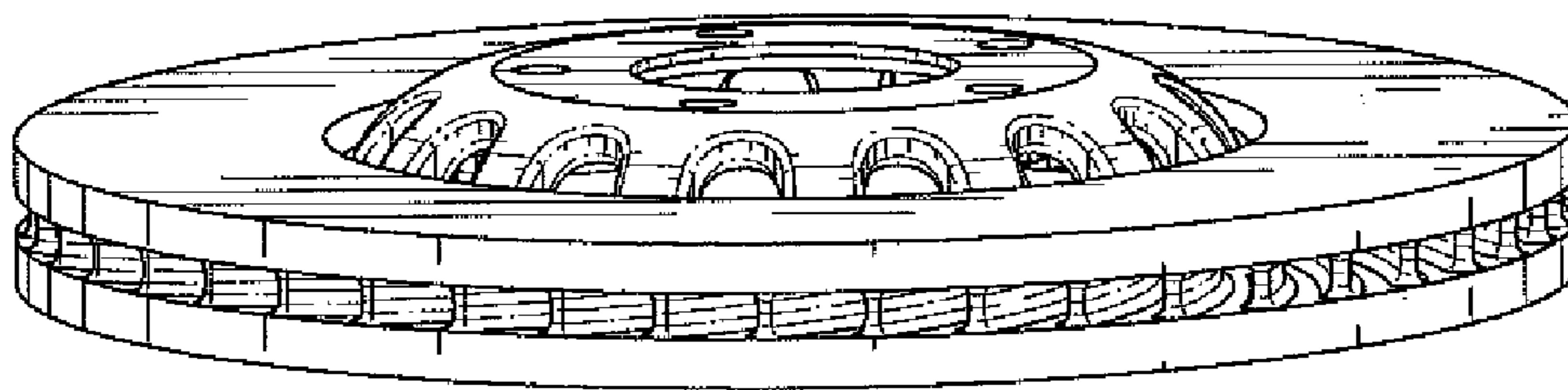

FIG. 2

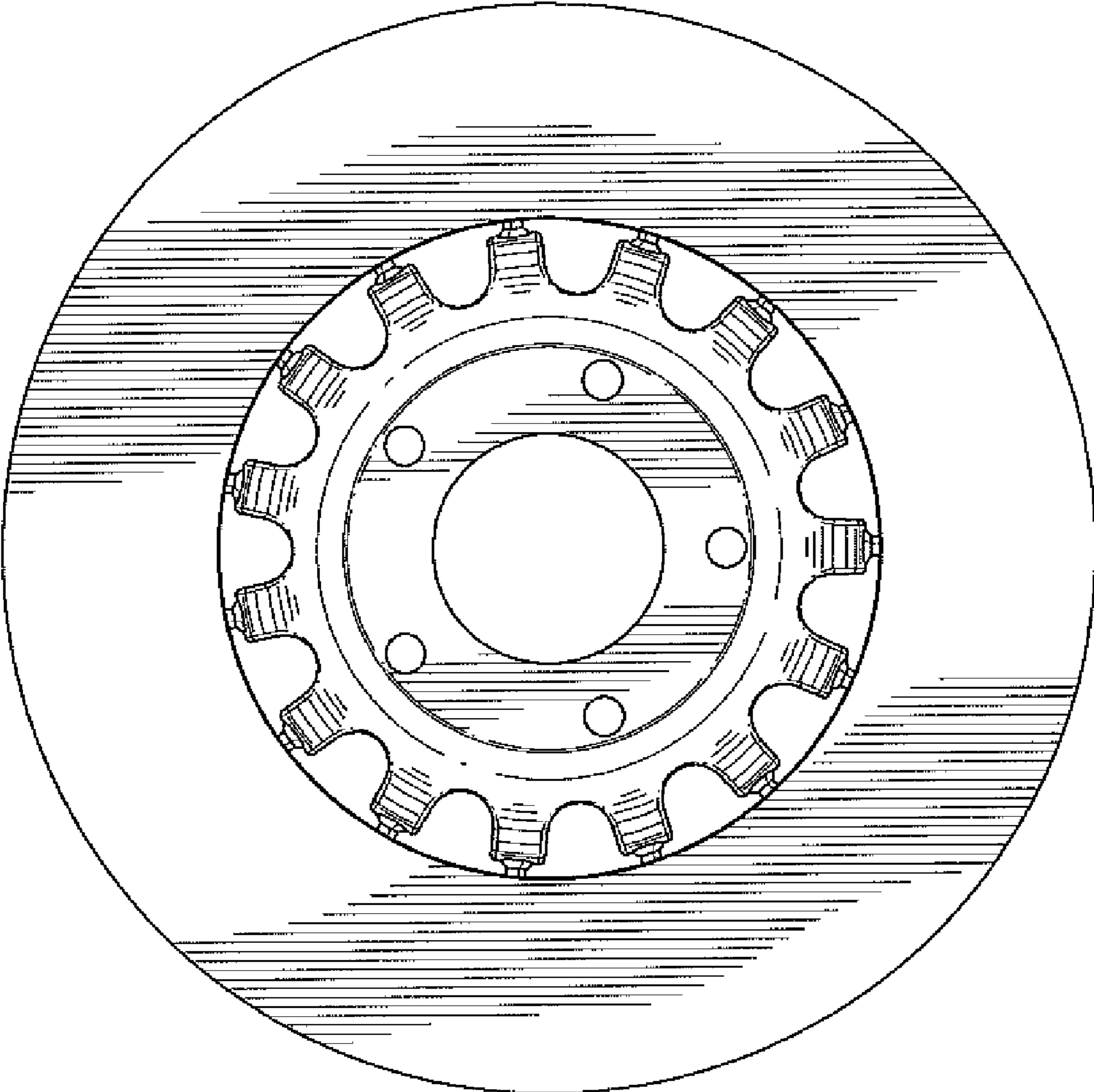

FIG. 3

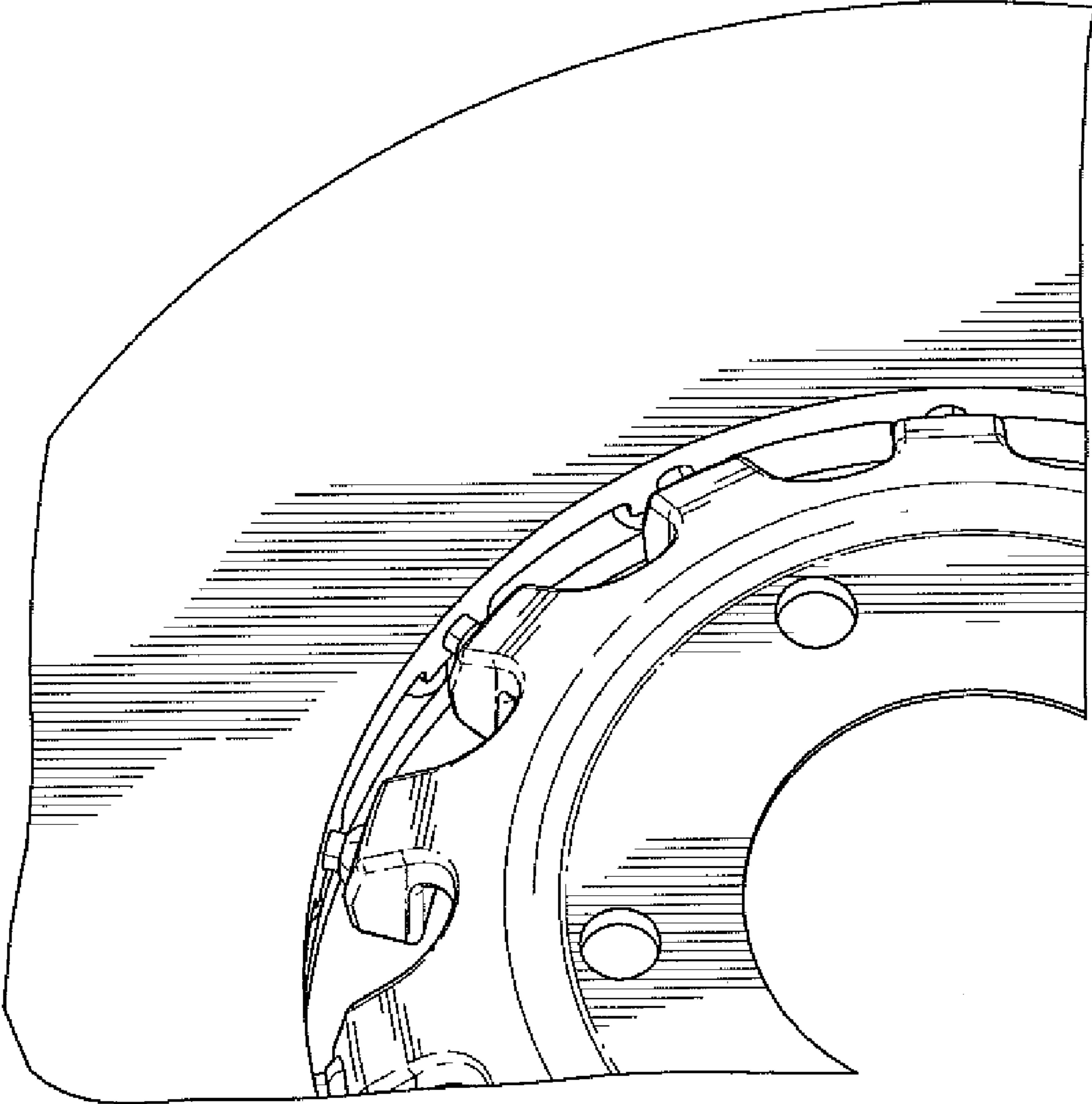

FIG.4

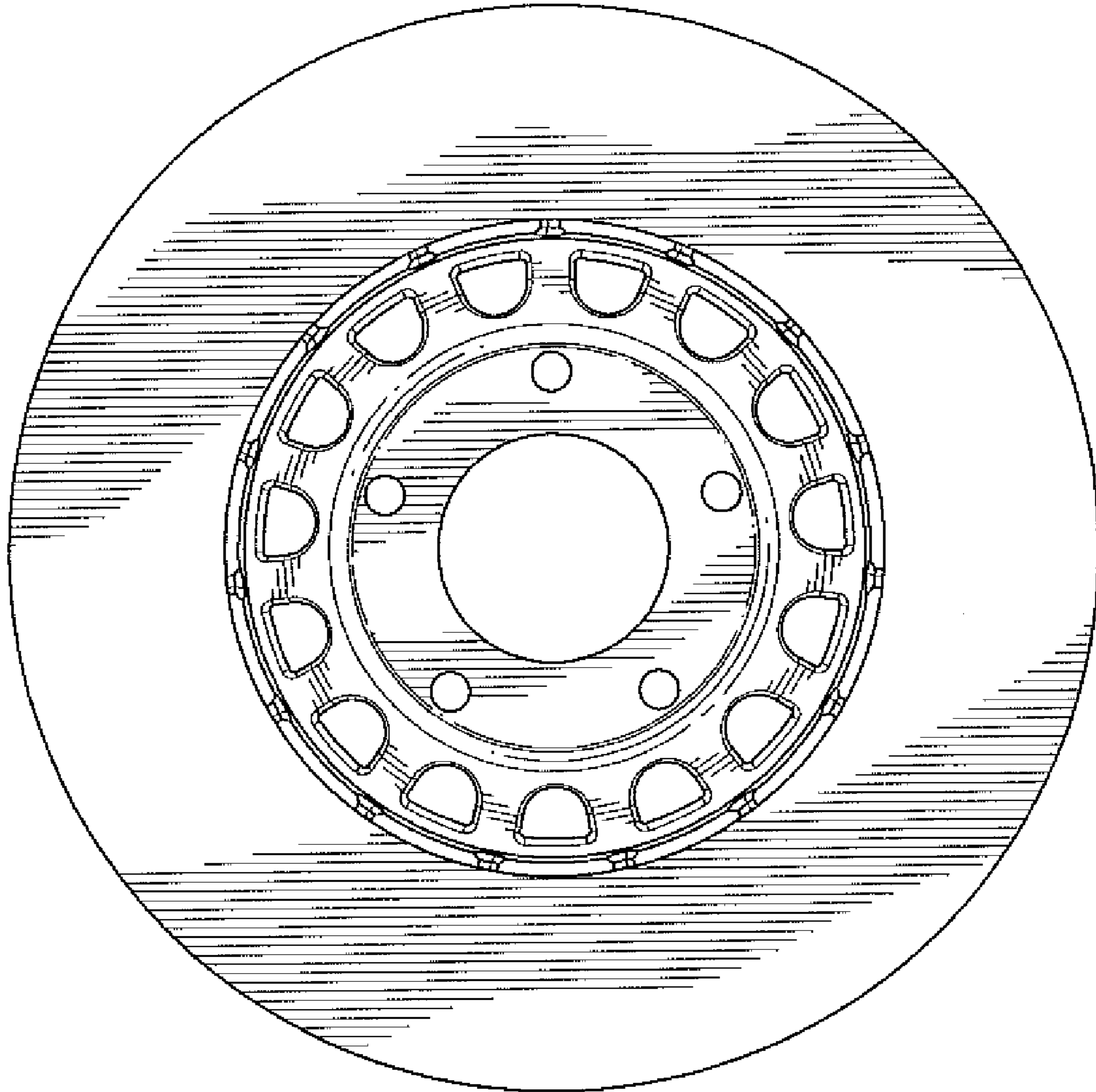

FIG. 5

UNITED STATES PATENT AND TRADEMARK OFFICE
CERTIFICATE OF CORRECTION

PATENT NO. : Des. 605,099 S
APPLICATION NO. : 29/306252
DATED : December 1, 2009
INVENTOR(S) : Johann Schmitz, Ingo Hoffmann and Manfred Pallentien

Page 1 of 1

It is certified that error appears in the above-identified patent and that said Letters Patent is hereby corrected as shown below:

Title Page, Item (73) please correct "Schwabische Huttenwerke Automotive GmbH & Co. KG" to read as follows: --Schwäbische Hüttenwerke Automotive GmbH & Co. KG--

Signed and Sealed this

Fifteenth Day of June, 2010

A handwritten signature in black ink that reads "David J. Kappos". The signature is written in a cursive, flowing style.

David J. Kappos
Director of the United States Patent and Trademark Office