

US00D605090S

(12) **United States Design Patent**
Tanaka et al.

(10) **Patent No.:** **US D605,090 S**

(45) **Date of Patent:** **** Dec. 1, 2009**

(54) **MOTORCYCLE**

(75) Inventors: **Shunji Tanaka**, Kobe (JP); **Yu Shibuta**,
Kobe (JP); **Toshiya Furuta**, Kobe (JP)

(73) Assignee: **Kawasaki Jukogyo Kabushiki Kaisha**,
Hyogo (JP)

(**) Term: **14 Years**

(21) Appl. No.: **29/333,864**

(22) Filed: **Mar. 16, 2009**

(30) **Foreign Application Priority Data**

Sep. 18, 2008 (JP) 2008-023845

(51) **LOC (9) Cl.** **12-11**

(52) **U.S. Cl.** **D12/110**

(58) **Field of Classification Search** D12/110;
180/219, 220, 225, 229

See application file for complete search history.

(56) **References Cited**

U.S. PATENT DOCUMENTS

D457,836 S * 5/2002 Kohama et al. D12/110

D496,309 S * 9/2004 Fukumoto et al. D12/110

D504,844 S * 5/2005 Sasanami D12/110
D517,958 S * 3/2006 Matsumura et al. D12/110
D559,156 S * 1/2008 Uemoto et al. D12/110
D588,961 S * 3/2009 Tanaka et al. D12/110

* cited by examiner

Primary Examiner—Cathron C Brooks

Assistant Examiner—Linda G. Brooks

(57) **CLAIM**

The ornamental design for a motorcycle, as shown and described.

DESCRIPTION

FIG. 1 is a front elevational view of a motorcycle showing our new design;

FIG. 2 is a rear elevational view thereof;

FIG. 3 is a left side elevational view thereof;

FIG. 4 is a right side elevational view thereof;

FIG. 5 is a top plan view thereof;

FIG. 6 is a bottom plan view thereof;

FIG. 7 is a front perspective view thereof; and,

FIG. 8 is a rear perspective view thereof.

1 Claim, 8 Drawing Sheets

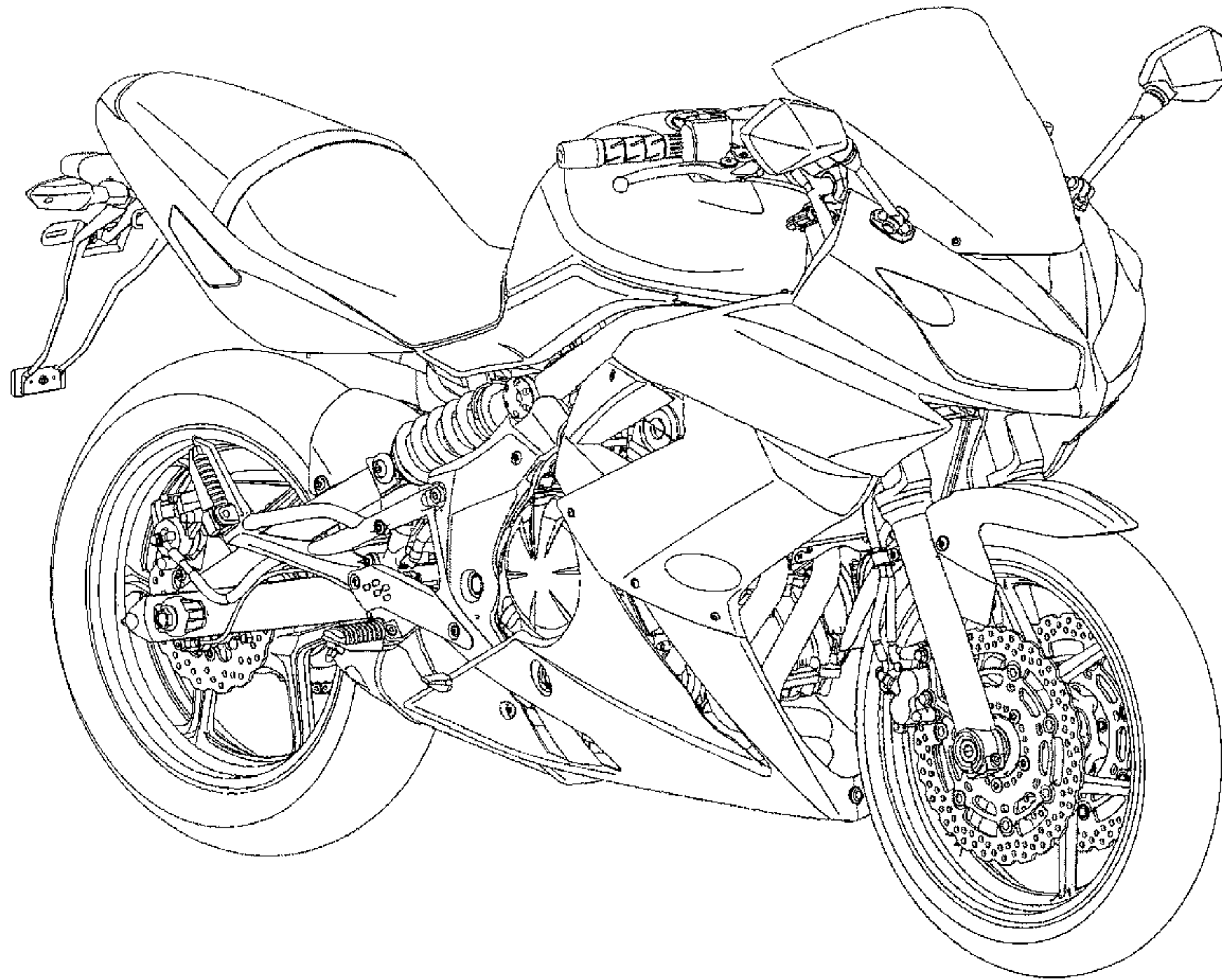
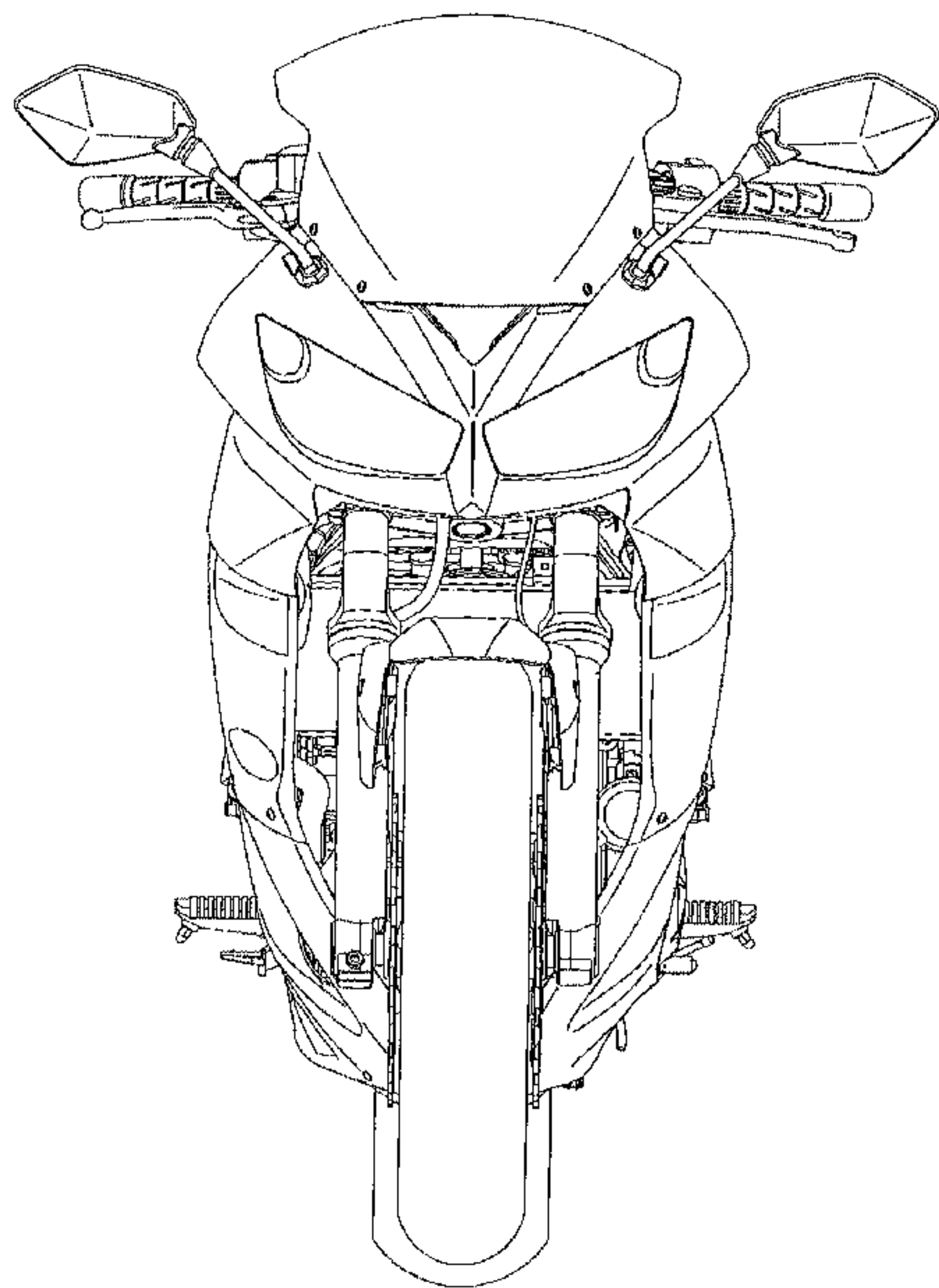

Fig. 1

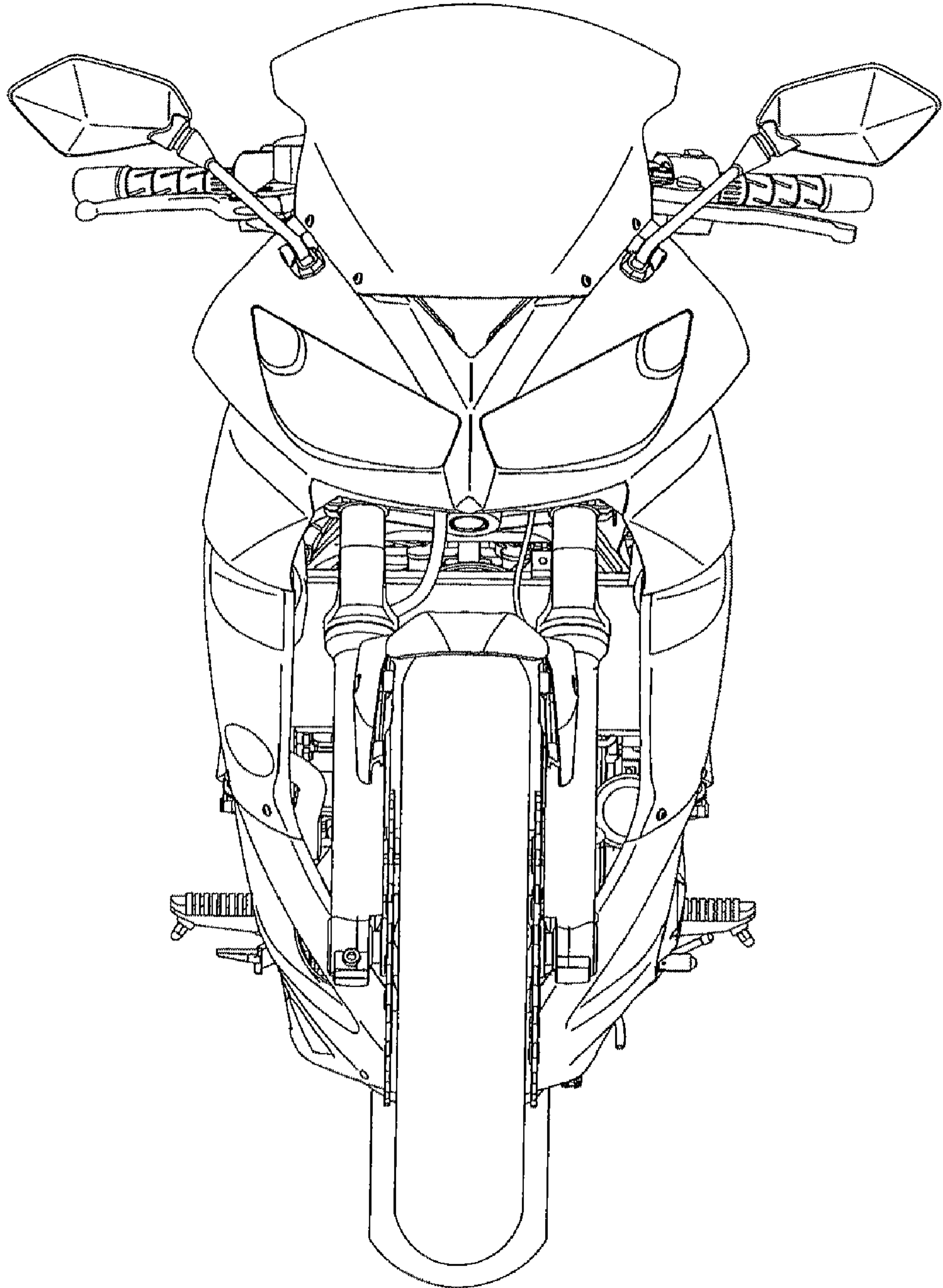
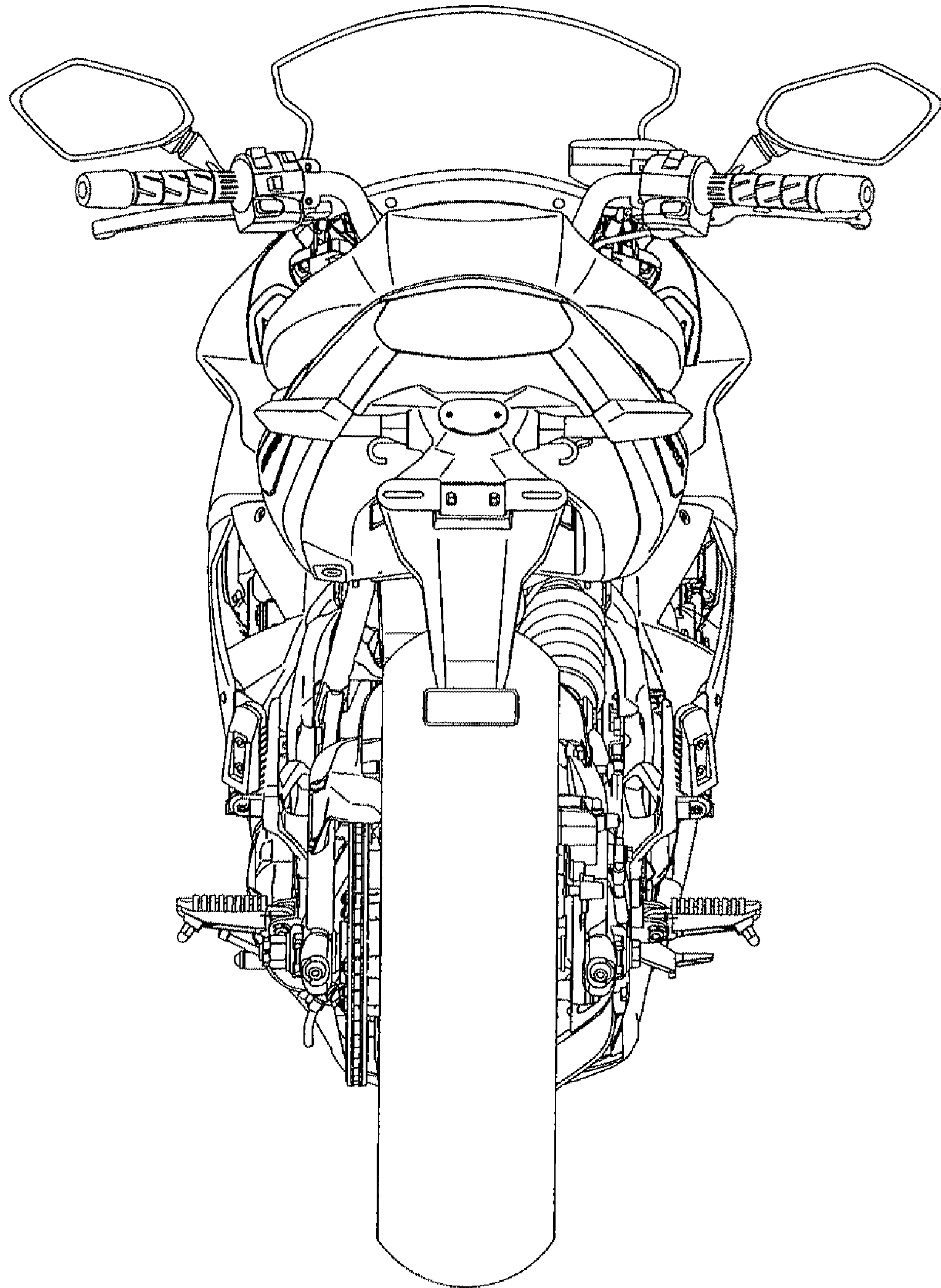

Fig. 2



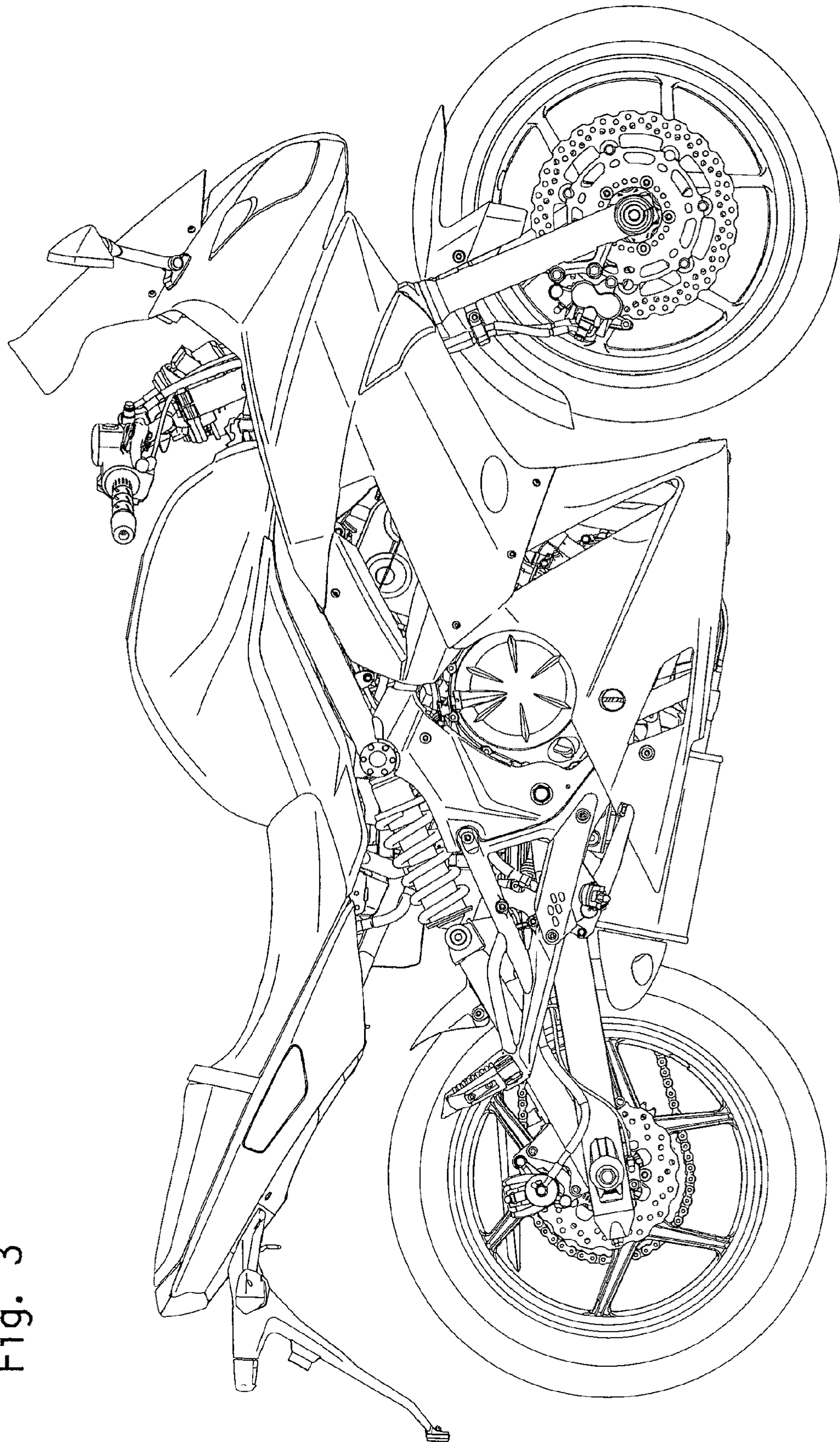

Fig. 3

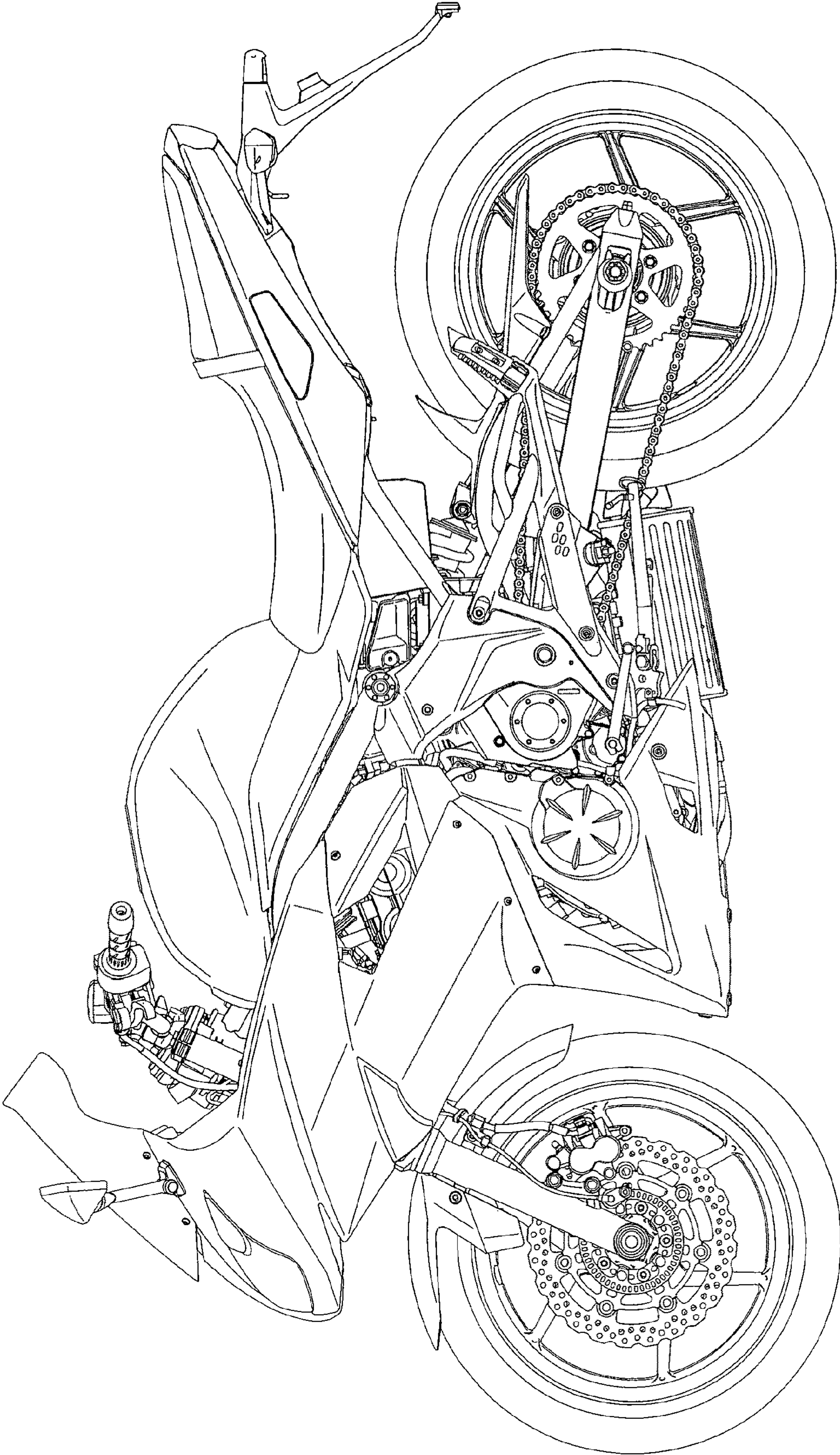

Fig. 4

Fig. 5

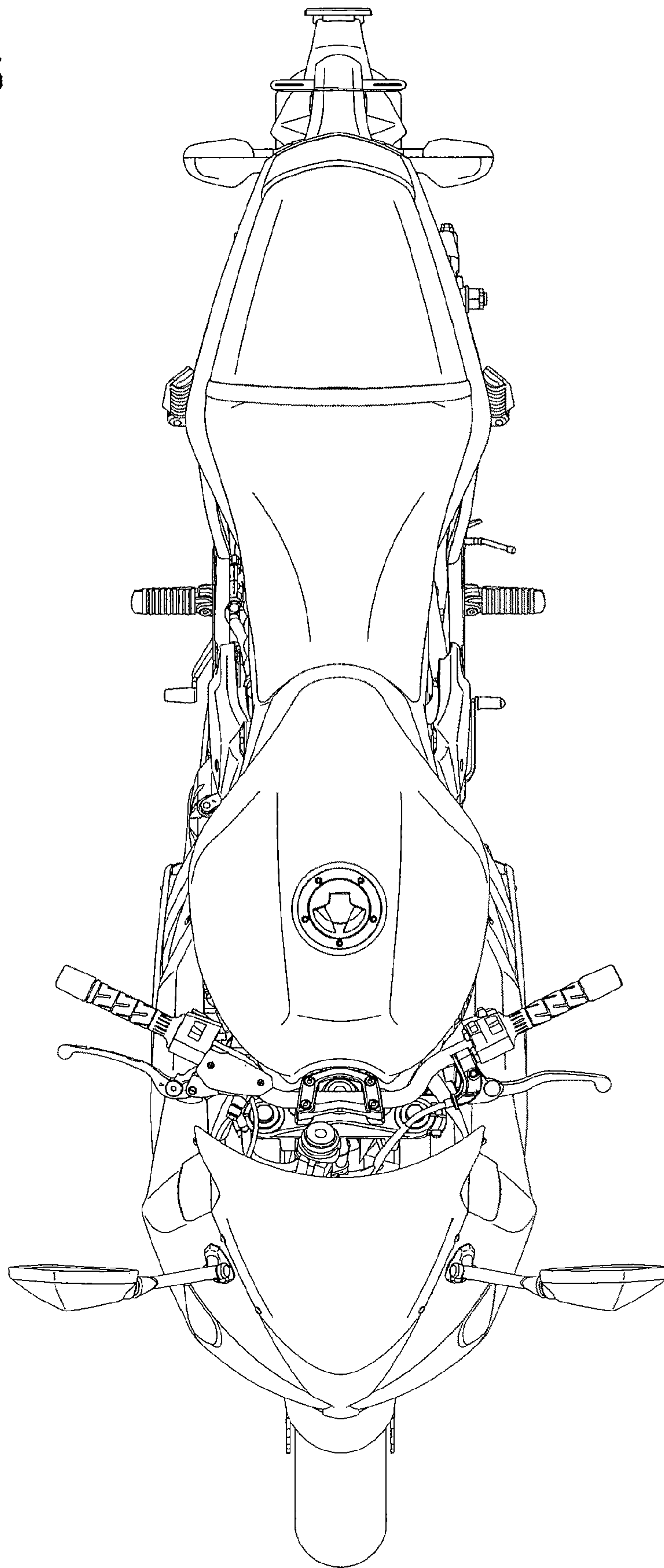
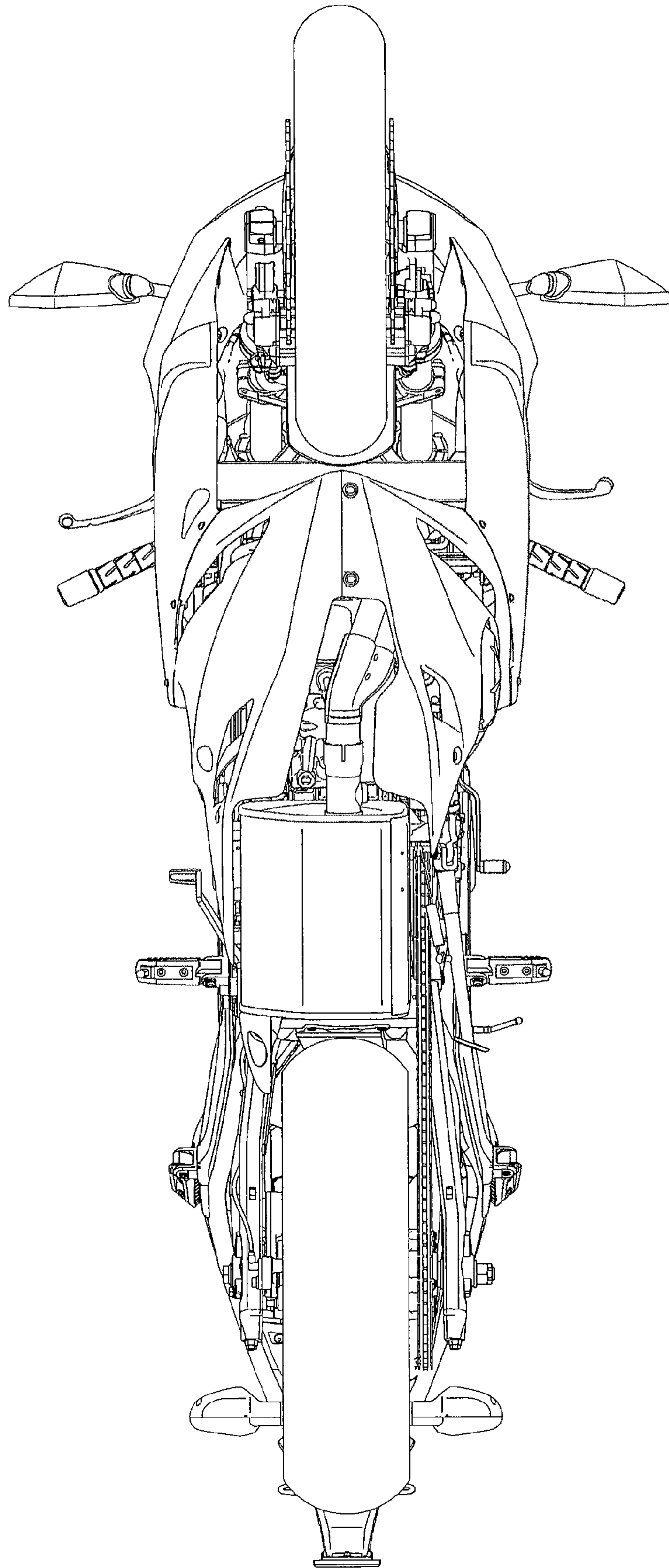

Fig. 6



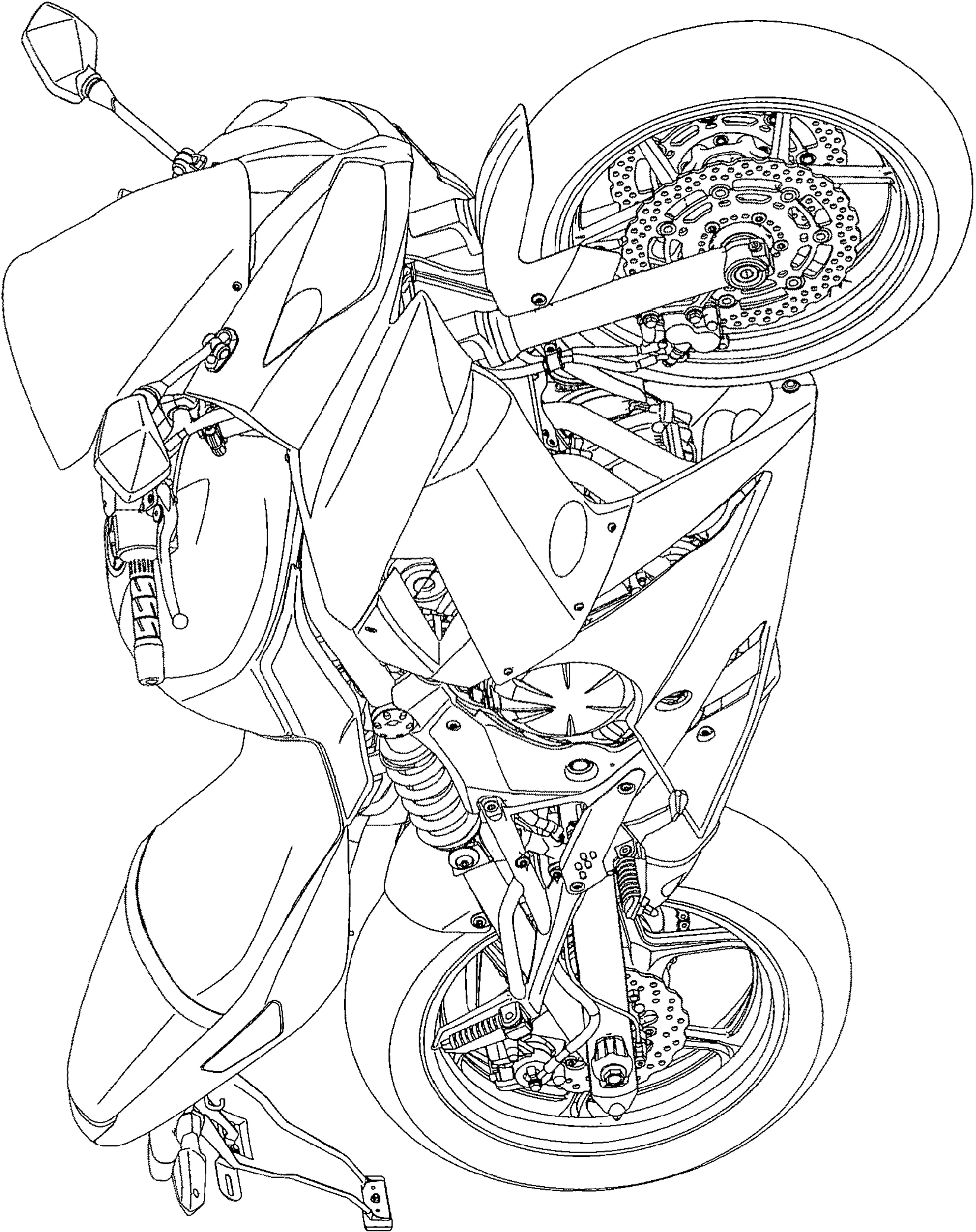

Fig. 7

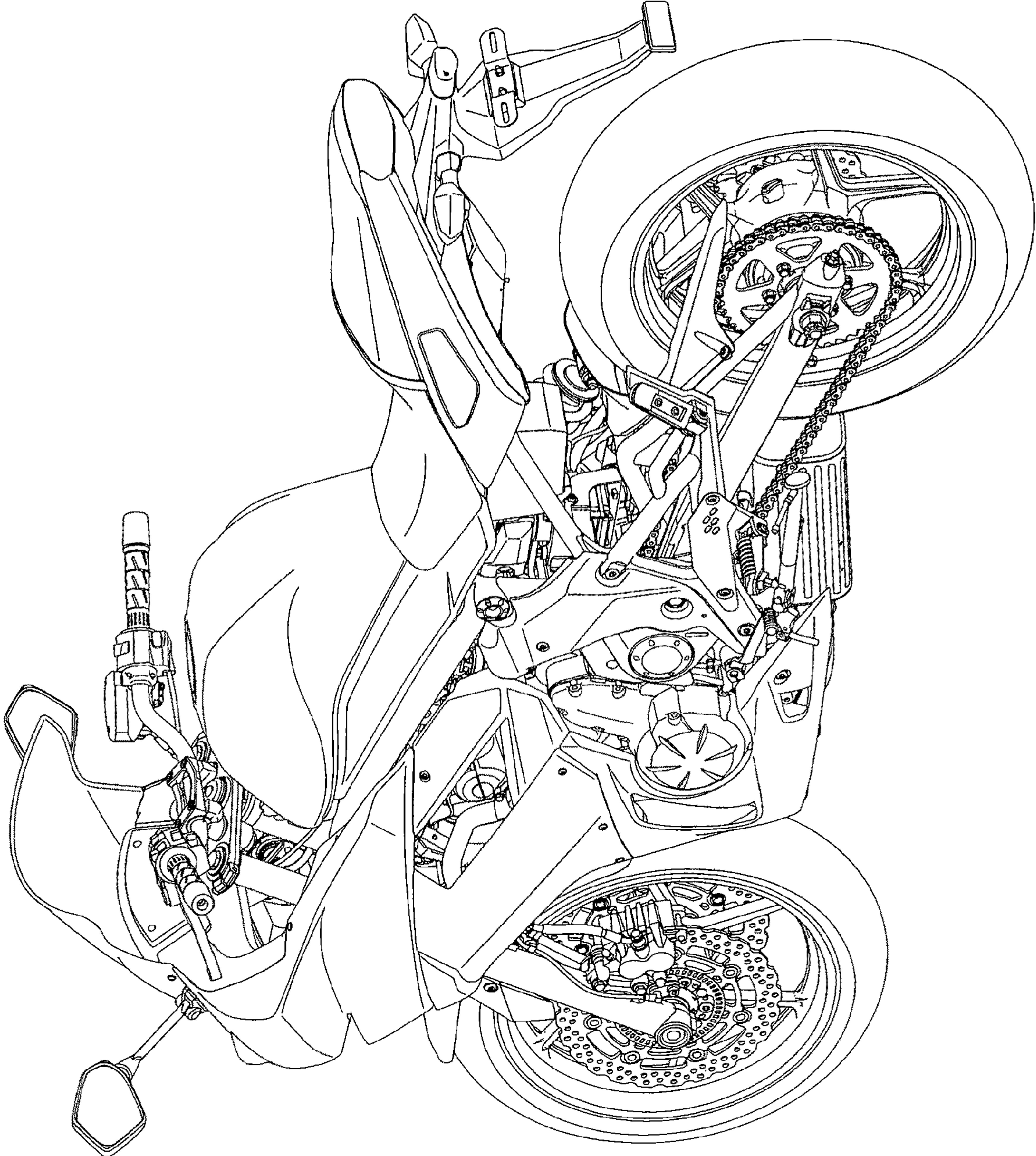

Fig. 8