



US00D604841S

(12) **United States Design Patent**  
**Crawford et al.**

(10) **Patent No.:** **US D604,841 S**  
(45) **Date of Patent:** **\*\* Nov. 24, 2009**

- (54) **SAFETY BLOOD COLLECTION NEEDLE DEVICE**
- (75) Inventors: **Jamieson Crawford**, Cliffside Park, NJ (US); **Robert Ellis**, Wayne, NJ (US); **Benjamin Bartfeld**, Pompton Lakes, NJ (US); **Bradley M. Wilkinson**, North Haledon, NJ (US); **Neville Yu Leng Chia**, Singapore (SG)
- (73) Assignee: **Becton, Dickinson and Company**, Franklin Lakes, NJ (US)
- (\*\*) Term: **14 Years**
- (21) Appl. No.: **29/323,447**
- (22) Filed: **Aug. 26, 2008**
- (51) **LOC (9) Cl.** ..... **24-02**
- (52) **U.S. Cl.** ..... **D24/130**
- (58) **Field of Classification Search** ..... D24/112, D24/130, 113, 146; 604/110, 192, 195-196, 604/198, 410, 576-578, 583; 263/363-365
- (56) See application file for complete search history.  
**References Cited**

**U.S. PATENT DOCUMENTS**

4,573,976 A 3/1986 Sampson et al.

(Continued)

**OTHER PUBLICATIONS**

U.S. Appl. No. 11/572,220; filed Aug. 26, 2008; Swenson.

(Continued)

*Primary Examiner*—T. Chase Nelson

*Assistant Examiner*—Eric L Goodman

(74) *Attorney, Agent, or Firm*—The Webb Law Firm

(57) **CLAIM**

The ornamental design for a safety blood collection needle device, as shown and described.

**DESCRIPTION**

FIG. 1 is a perspective view of a safety blood collection needle device having a needle guard disposed over the needle and a shield in an initial position in accordance with an embodiment of the present invention;

FIG. 2 is a top view of the safety blood collection needle device of FIG. 1;

FIG. 3 is a left side view of the safety blood collection needle device of FIG. 1;

FIG. 4 is a front view of the safety blood collection needle device of FIG. 1;

FIG. 5 is a rear view of the safety blood collection needle device of FIG. 1;

FIG. 6 is a right side view of the safety blood collection needle device of FIG. 1;

FIG. 7 is a bottom view of the safety blood collection needle device of FIG. 1;

FIG. 8 is a perspective view of the safety blood collection needle device of FIG. 1 having the needle guard removed and the shield in a retracted position in accordance with an embodiment of the present invention;

FIG. 9 is a top view of the safety blood collection needle device of FIG. 8;

FIG. 10 is a left side view of the safety blood collection needle device of FIG. 8;

FIG. 11 is a front view of the safety blood collection needle device of FIG. 8;

FIG. 12 is a rear view of the safety blood collection needle device of FIG. 8;

FIG. 13 is a right side view of the safety blood collection needle device of FIG. 8;

FIG. 14 is a bottom view of the safety blood collection needle device of FIG. 8;

FIG. 15 is a perspective view of the safety blood collection needle device of FIG. 1 having the needle guard removed and the shield in a shielded position in accordance with an embodiment of the present invention;

FIG. 16 is a top view of the safety blood collection needle device of FIG. 15;

FIG. 17 is a left side view of the safety blood collection needle device of FIG. 15;

FIG. 18 is a front view of the safety blood collection needle device of FIG. 15;

FIG. 19 is a rear view of the safety blood collection needle device of FIG. 15;

FIG. 20 is a right side view of the safety blood collection needle device of FIG. 15; and,

FIG. 21 is a bottom view of the safety blood collection needle device of FIG. 15.

The portions of the safety blood collection needle device shown in broken lines form no part of the claimed design.

**1 Claim, 14 Drawing Sheets**

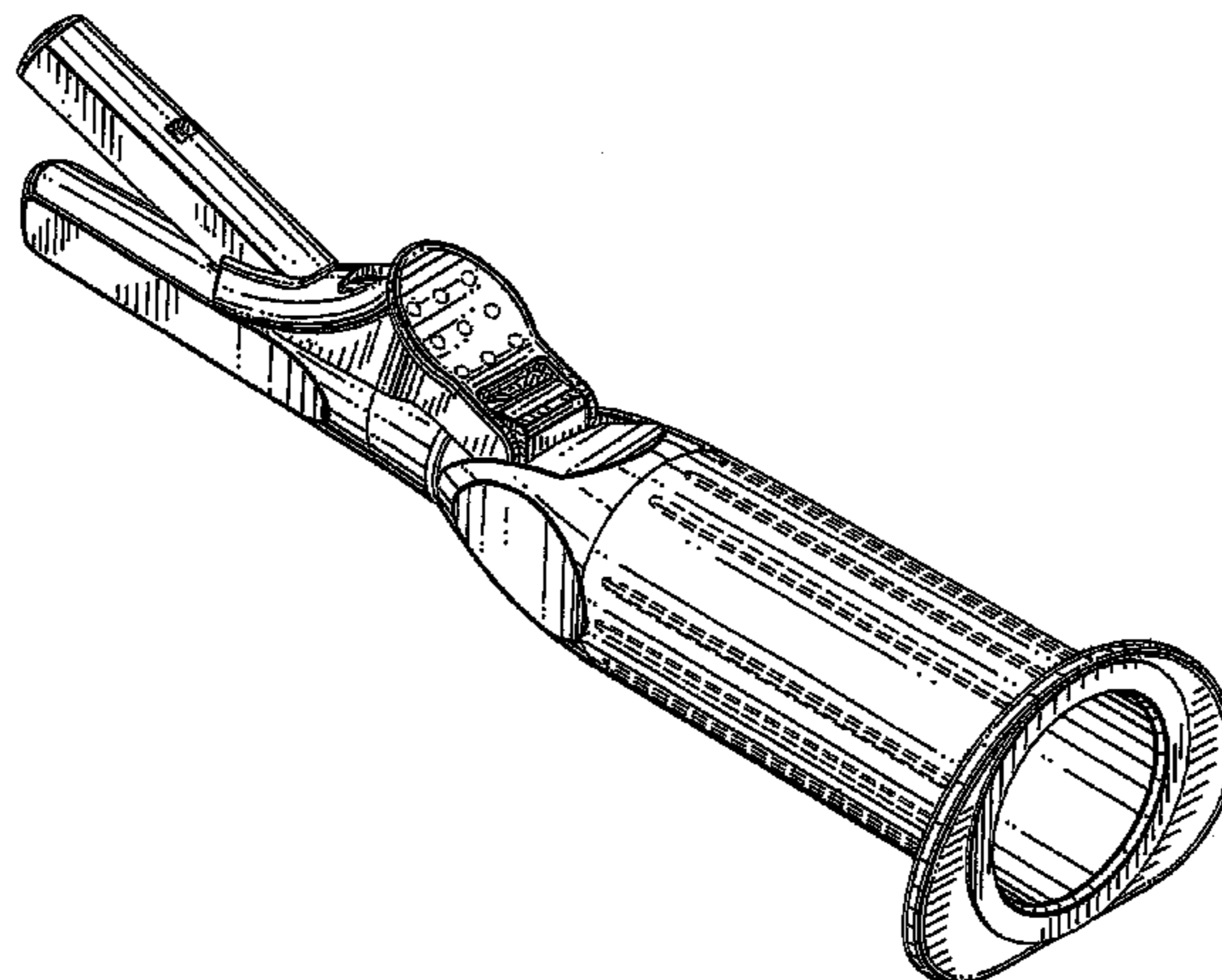

# US D604,841 S

## U.S. PATENT DOCUMENTS

4,641,663	A	2/1987	Juhn	6,780,169	B2	8/2004	Crawford
4,795,443	A	1/1989	Permenter et al.	6,837,877	B2	1/2005	Zurcher
4,840,619	A	6/1989	Hughes	6,869,415	B2	3/2005	Asbaghi
4,894,055	A	1/1990	Sudnak	6,905,483	B2 *	6/2005	Newby et al. .... 604/164.08
4,900,307	A	2/1990	Kulli	6,949,086	B2 *	9/2005	Ferguson et al. .... 604/198
4,994,046	A	2/1991	Wesson et al.	6,984,223	B2 *	1/2006	Newby et al. .... 604/263
5,015,241	A	5/1991	Feimer	6,997,913	B2 *	2/2006	Wilkinson ..... 604/263
5,215,534	A	6/1993	De Harde et al.	7,001,363	B2	2/2006	Ferguson et al.
5,222,502	A	6/1993	Kurose	7,041,066	B2 *	5/2006	Wilkinson ..... 600/576
5,242,417	A	9/1993	Paudler	7,063,673	B2 *	6/2006	Marsden ..... 600/576
5,303,713	A	4/1994	Kurose	7,128,726	B2	10/2006	Crawford et al.
5,312,372	A	5/1994	DeHarde et al.	7,147,624	B2	12/2006	Hirsiger et al.
5,336,199	A	8/1994	Castillo et al.	7,163,526	B2	1/2007	Leong et al.
5,348,544	A	9/1994	Sweeney et al.	7,182,734	B2 *	2/2007	Saulenas et al. .... 600/573
5,356,392	A	10/1994	Firth et al.	7,198,618	B2 *	4/2007	Ferguson et al. .... 604/198
5,411,492	A	5/1995	Sturman et al.	7,201,740	B2 *	4/2007	Crawford ..... 604/198
5,466,223	A	11/1995	Bressler et al.	7,223,258	B2	5/2007	Crawford
5,501,675	A	3/1996	Erskine	7,428,773	B2	9/2008	Newby et al.
5,672,161	A	9/1997	Allen et al.	2002/0151852	A1	10/2002	Crawford et al.
5,676,658	A	10/1997	Erskine	2002/0151853	A1	10/2002	Crawford
5,702,369	A	12/1997	Mercereau	2002/0156425	A1	10/2002	Crawford et al.
5,704,920	A	1/1998	Gyure	2002/0161336	A1	10/2002	Crawford et al.
5,755,522	A	5/1998	Ito	2002/0193748	A1	12/2002	Cocker et al.
5,984,899	A	11/1999	D'Alessio et al.	2003/0093009	A1 *	5/2003	Newby et al. .... 600/576
D422,700	S	4/2000	Crawford et al.	2004/0010228	A1 *	1/2004	Swenson et al. .... 604/110
6,149,629	A	11/2000	Wilson et al.	2004/0059302	A1	3/2004	Crawford et al.
D436,169	S *	1/2001	Wilkinson et al. .... D24/130	2004/0092872	A1	5/2004	Botich et al.
D439,975	S *	4/2001	Wilkinson et al. .... D24/130	2004/0111057	A1 *	6/2004	Wilkinson ..... 604/110
D440,657	S *	4/2001	Wilkinson et al. .... D24/130	2004/0193120	A1 *	9/2004	Ferguson et al. .... 604/263
D442,280	S	5/2001	Crawford et al.	2004/0210197	A1 *	10/2004	Conway ..... 604/198
D445,183	S *	7/2001	McWethy et al. .... D24/130	2005/0004524	A1	1/2005	Newby et al.
6,261,263	B1	7/2001	Huet et al.	2005/0187493	A1	8/2005	Swenson et al.
6,298,541	B1	10/2001	Newby et al.	2005/0215951	A1 *	9/2005	Saulenas et al. .... 604/110
D450,834	S *	11/2001	Newby et al. .... D24/112	2005/0245879	A9	11/2005	Crawford
D460,180	S *	7/2002	Swenson ..... D24/130	2006/0036219	A1	2/2006	Alvin
D460,183	S *	7/2002	Wilkinson et al. .... D24/130	2007/0167914	A1	7/2007	Leong et al.
D461,245	S *	8/2002	Niermann ..... D24/130	2007/0179451	A1 *	8/2007	Sprinkle et al. .... 604/192
6,436,086	B1	8/2002	Newby et al.	2007/0282275	A1 *	12/2007	Ferguson et al. .... 604/198
6,440,104	B1	8/2002	Newby et al.				
6,524,276	B1 *	2/2003	Halseth et al. .... 604/110				
6,533,760	B2	3/2003	Leong				
6,592,556	B1	7/2003	Thorne				
6,623,456	B1	9/2003	Holdaway et al.				
6,635,032	B2	10/2003	Ward, Jr.				
6,648,855	B2	11/2003	Crawford et al.				
D484,976	S *	1/2004	Wilkinson ..... D24/130				
6,699,217	B2	3/2004	Bennett et al.				
6,712,792	B2	3/2004	Leong				

## OTHER PUBLICATIONS

U.S. Appl. No. 12/044,354; filed Mar. 7, 2008; Tan.  
 U.S. Appl. No. 12/044,469; filed Mar. 7, 2008; Crawford.  
 U.S. Appl. No. 12/206,273; filed Sep. 8, 2008; Tan.  
 U.S. Appl. No. 12/206,299; filed Sep. 8, 2008; Crawford.  
 U.S. Appl. No. 29/323,441; filed Aug. 26, 2008; Crawford.  
 U.S. Appl. No. 29/323,445; filed Aug. 26, 2008; Crawford.  
 U.S. Appl. No. 29/323,452; filed Aug. 26, 2008; Crawford.

\* cited by examiner

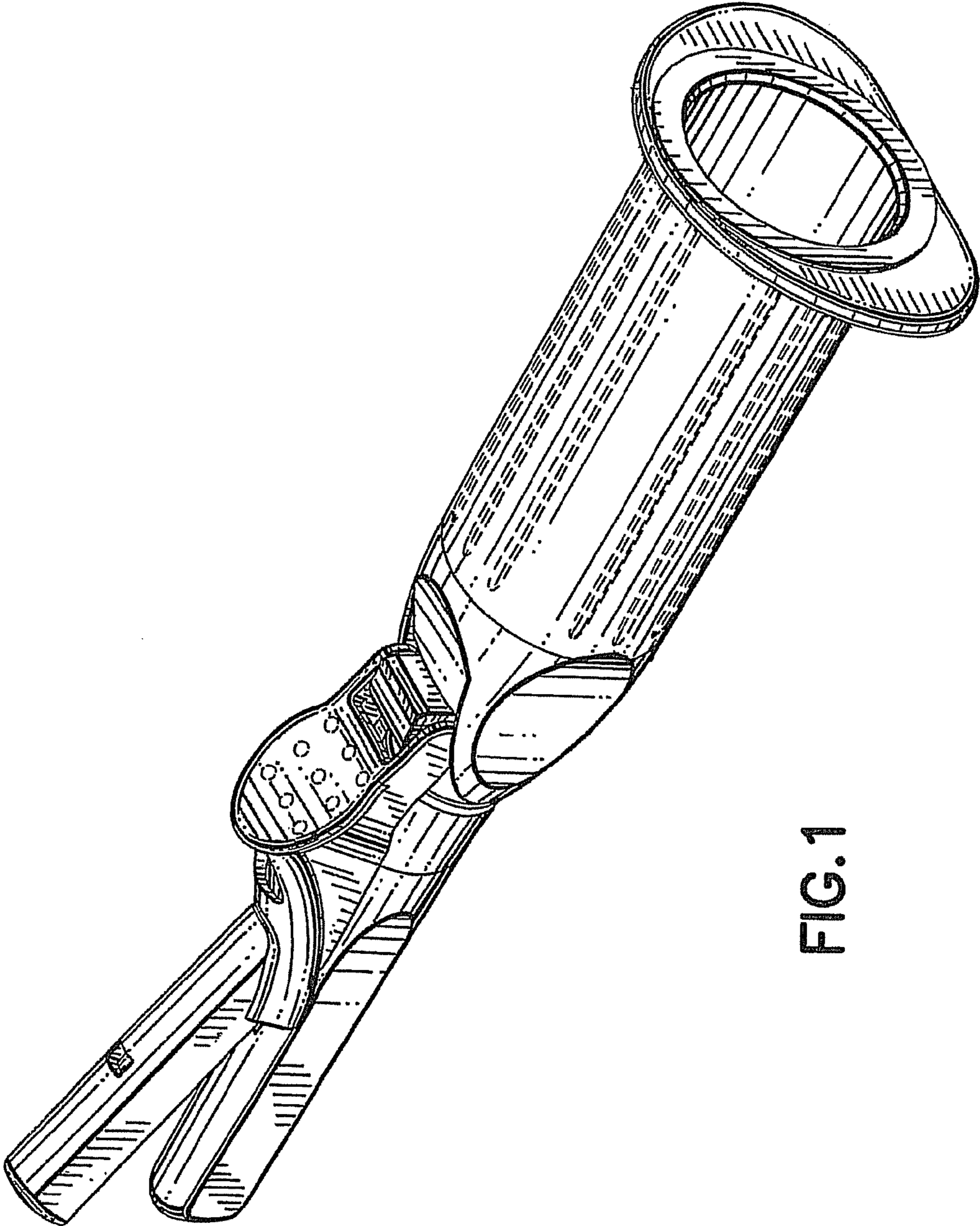

FIG. 1

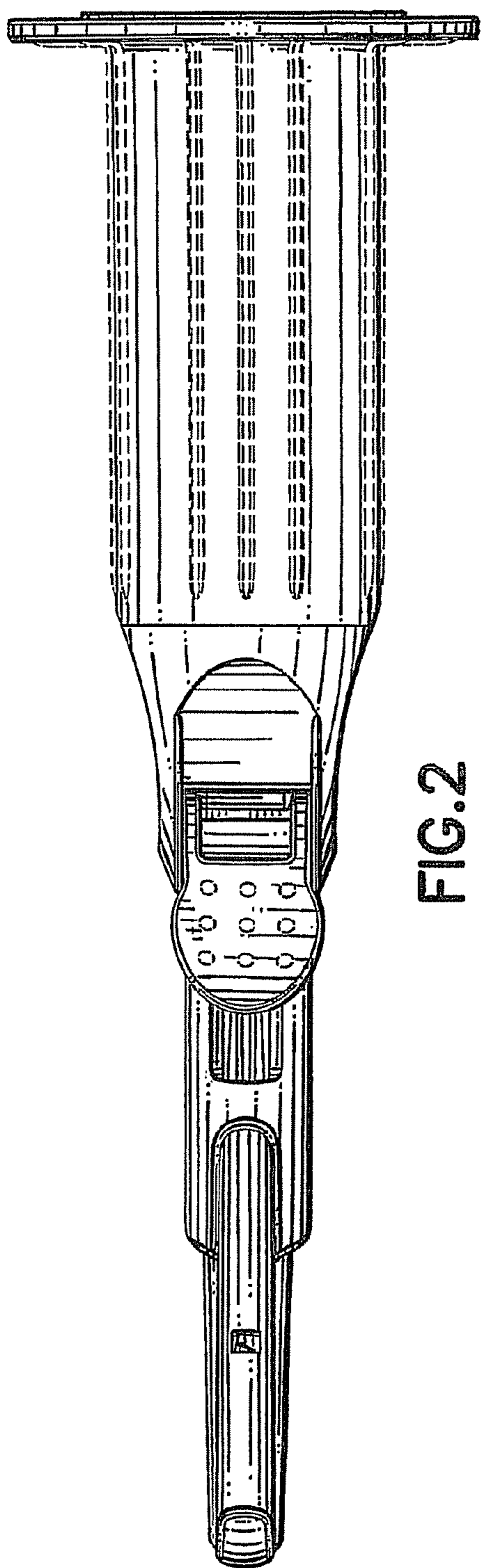

FIG. 2

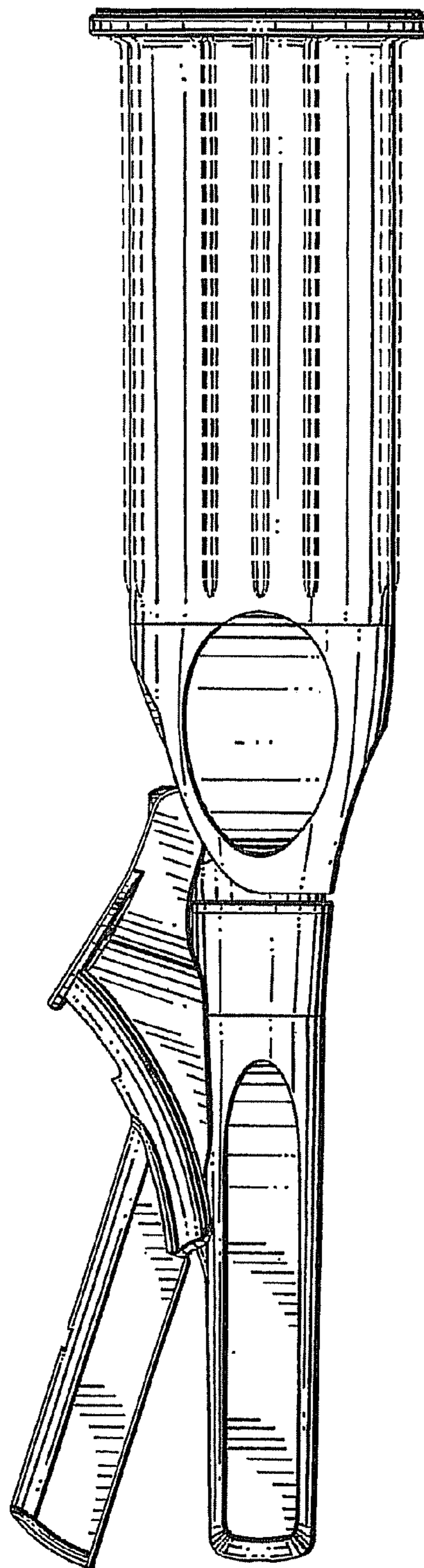

FIG. 3

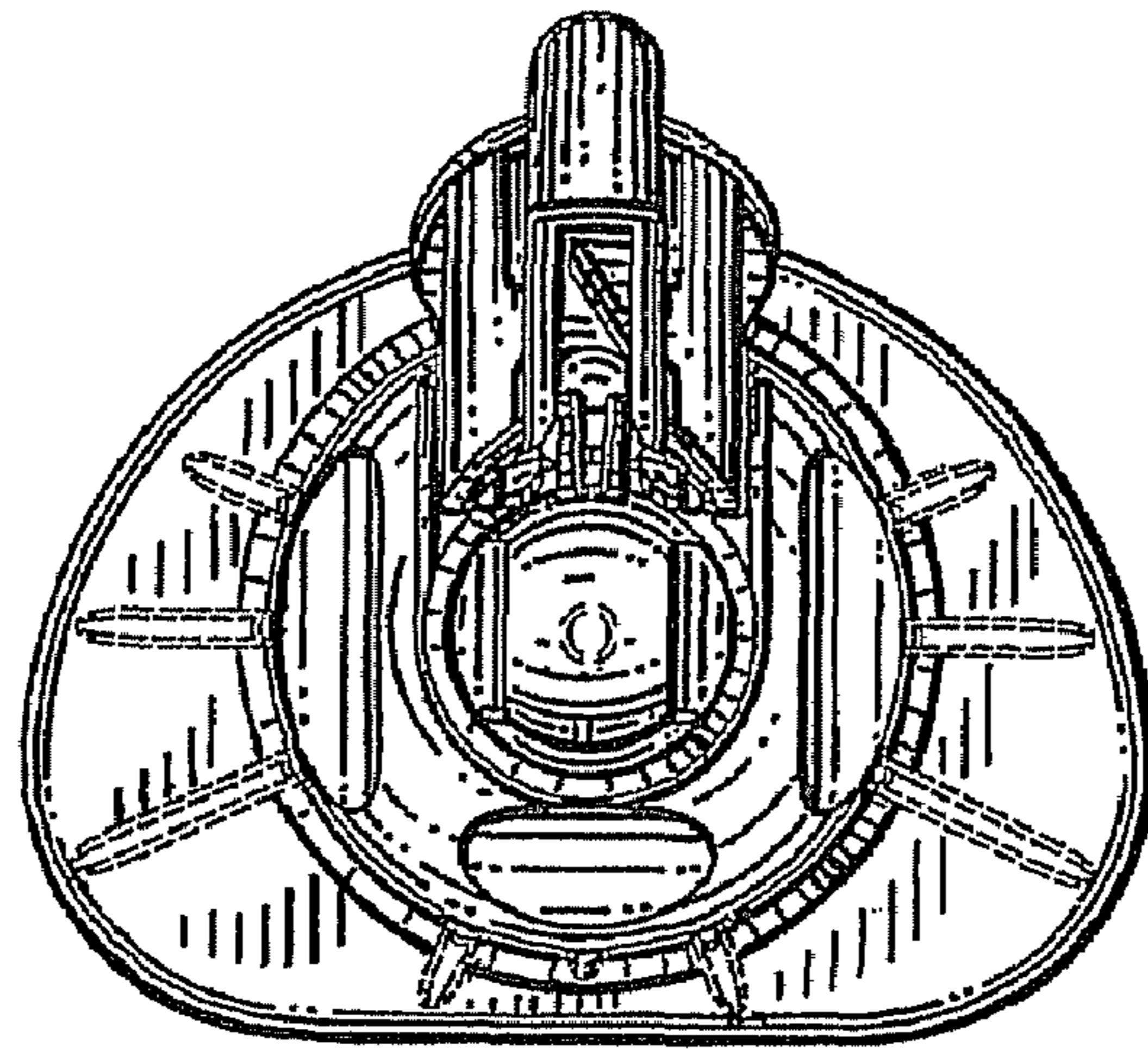

FIG. 4

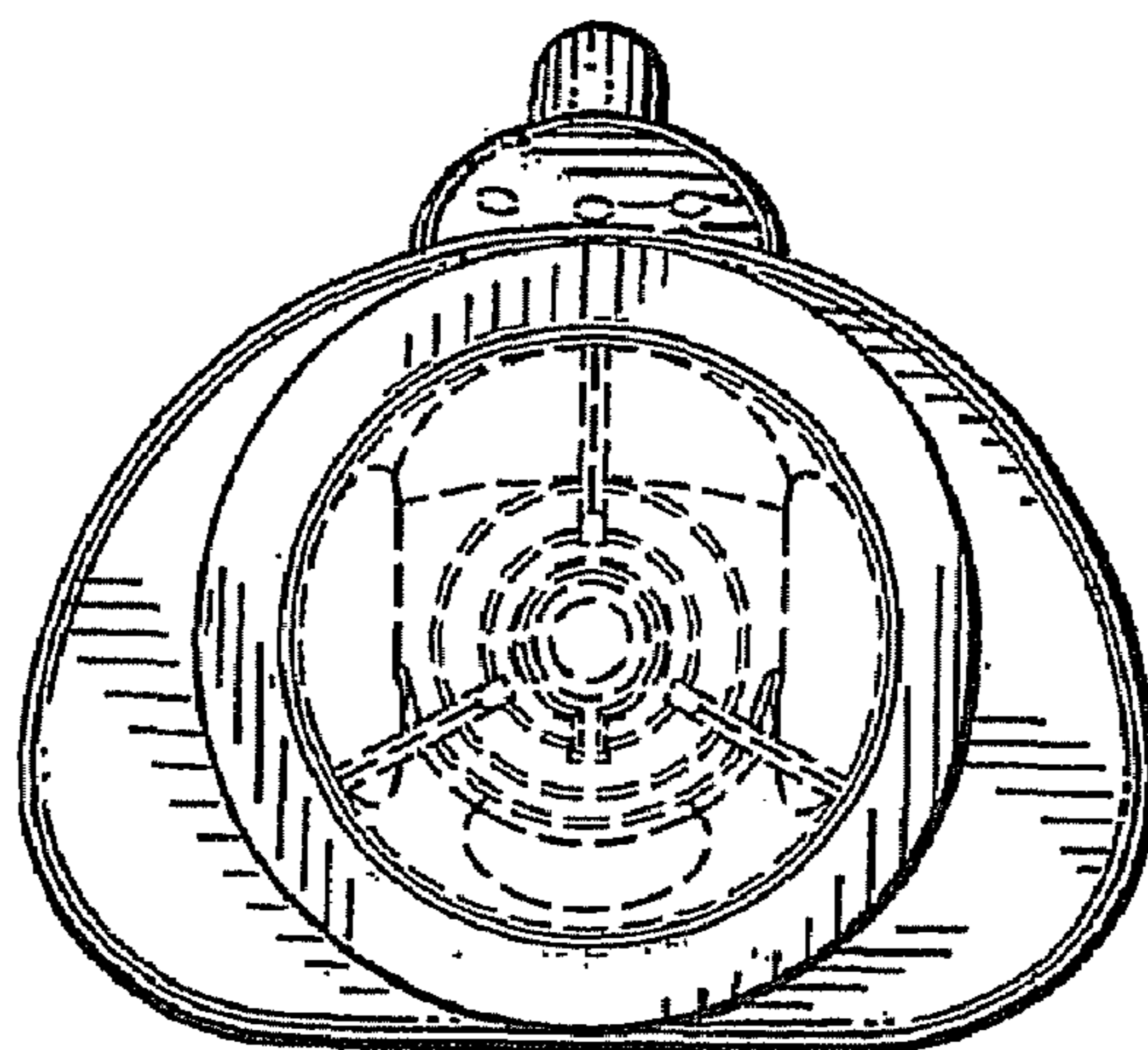

FIG. 5

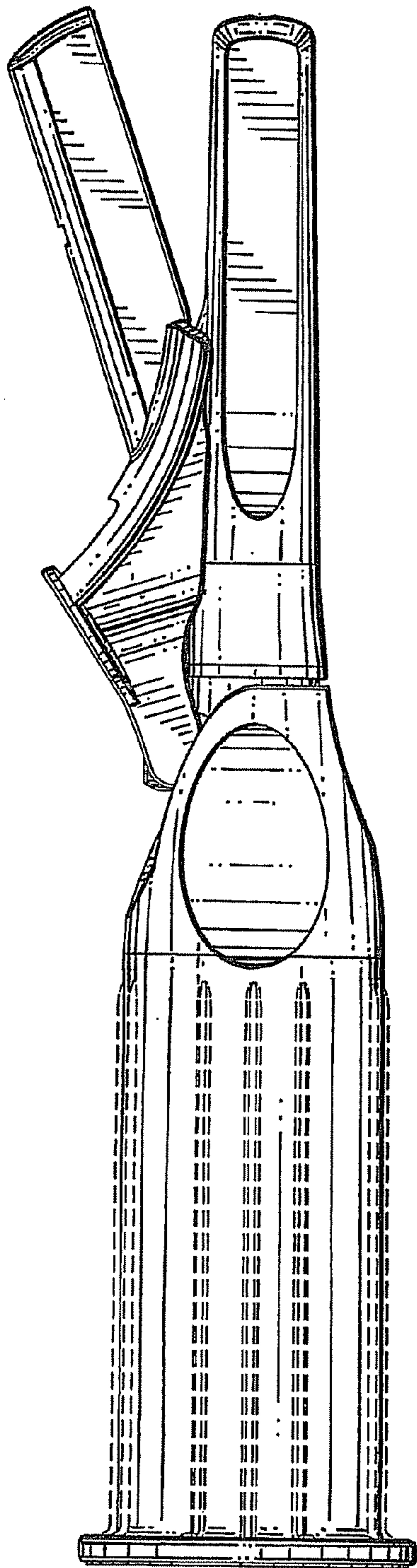

FIG. 6

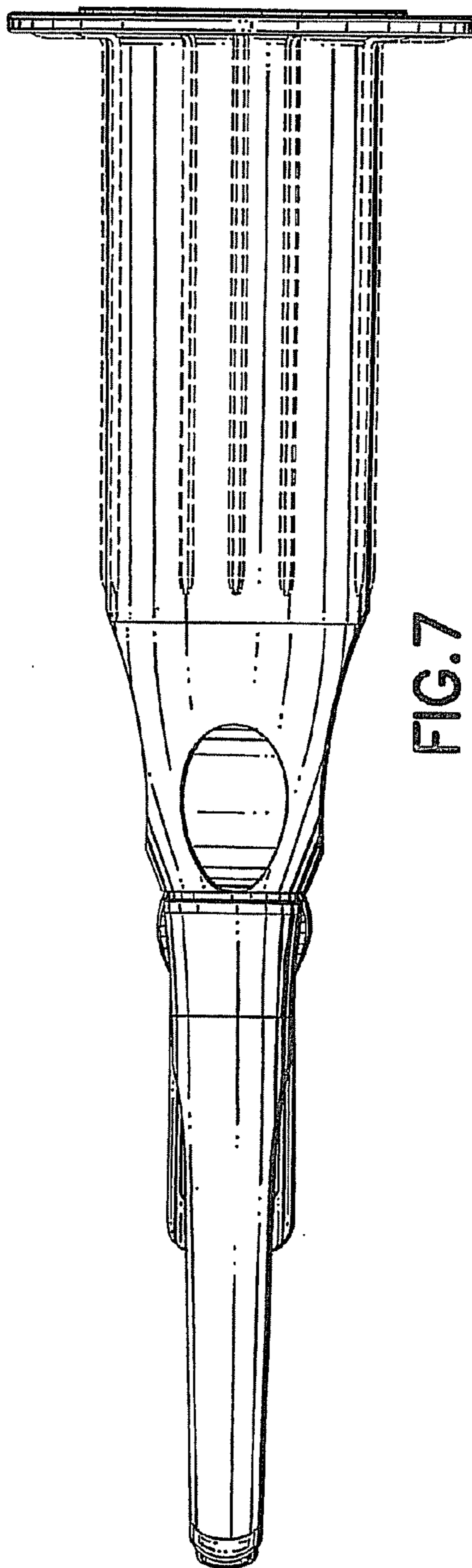

FIG. 7

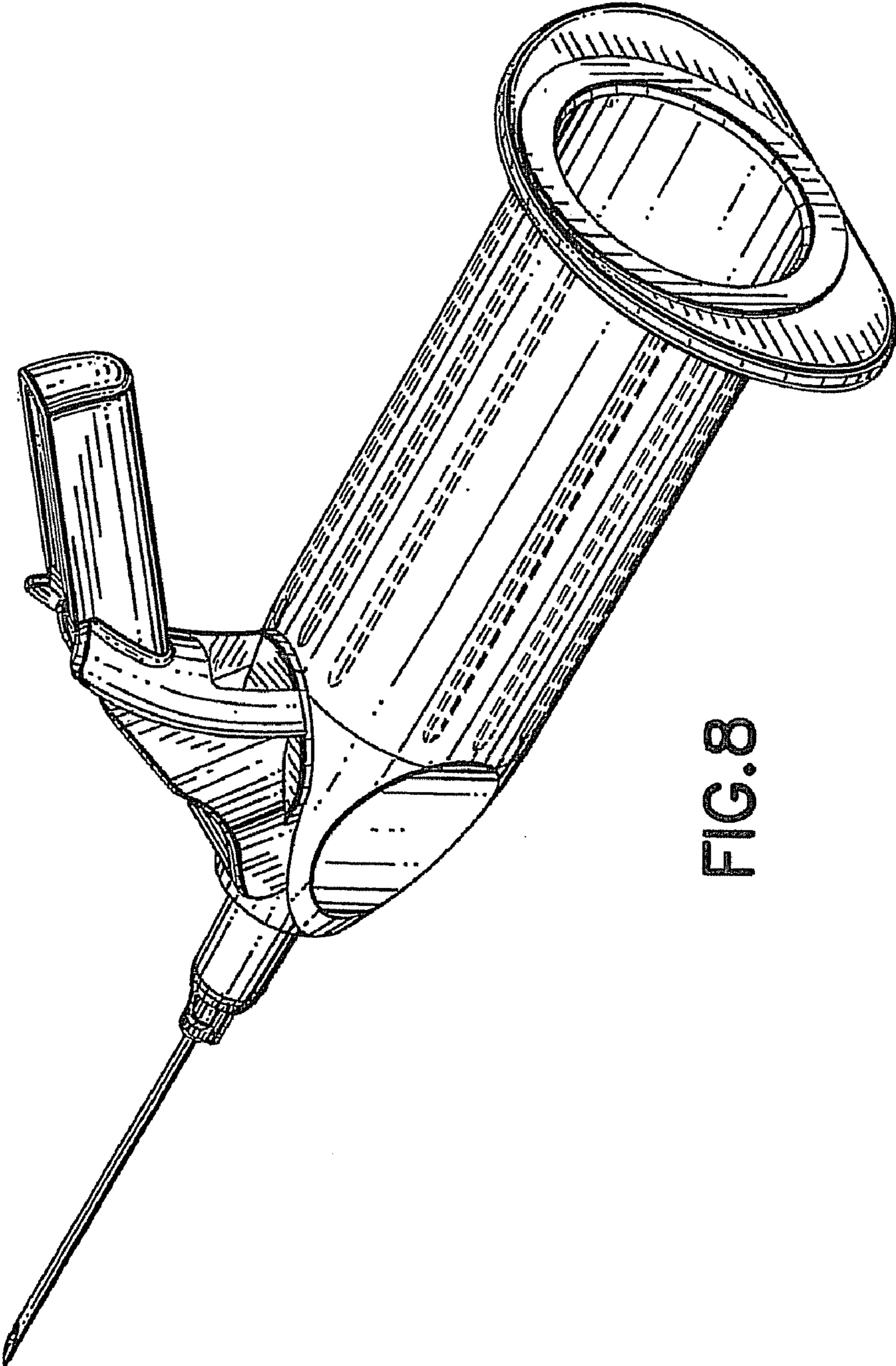

FIG. 8

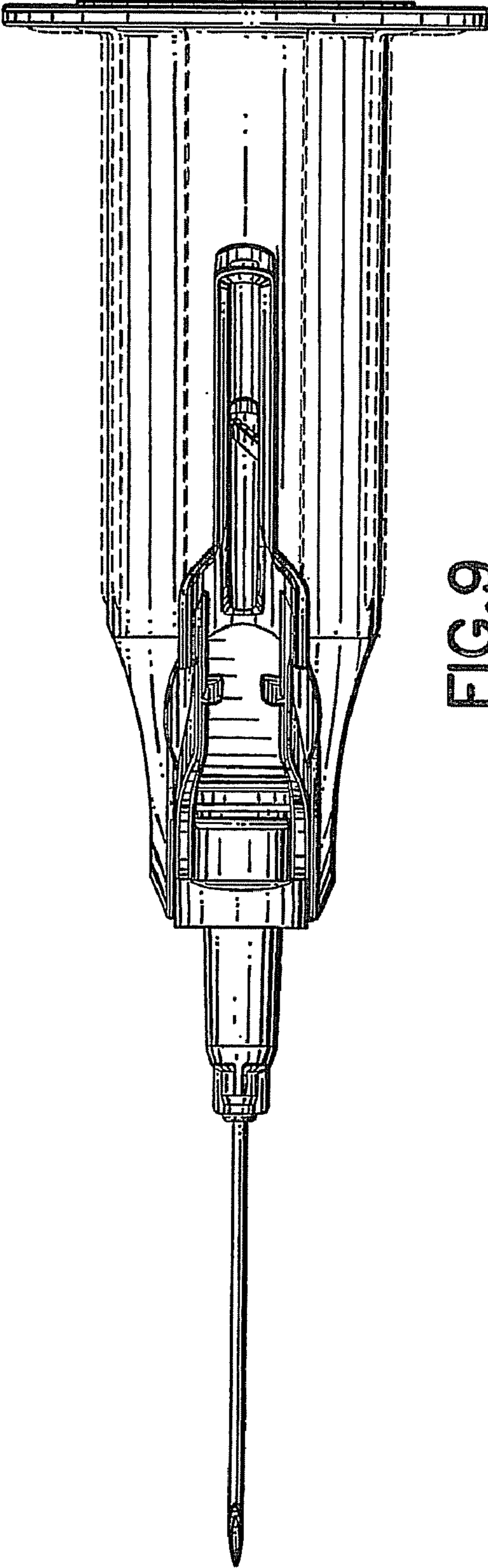

FIG. 9



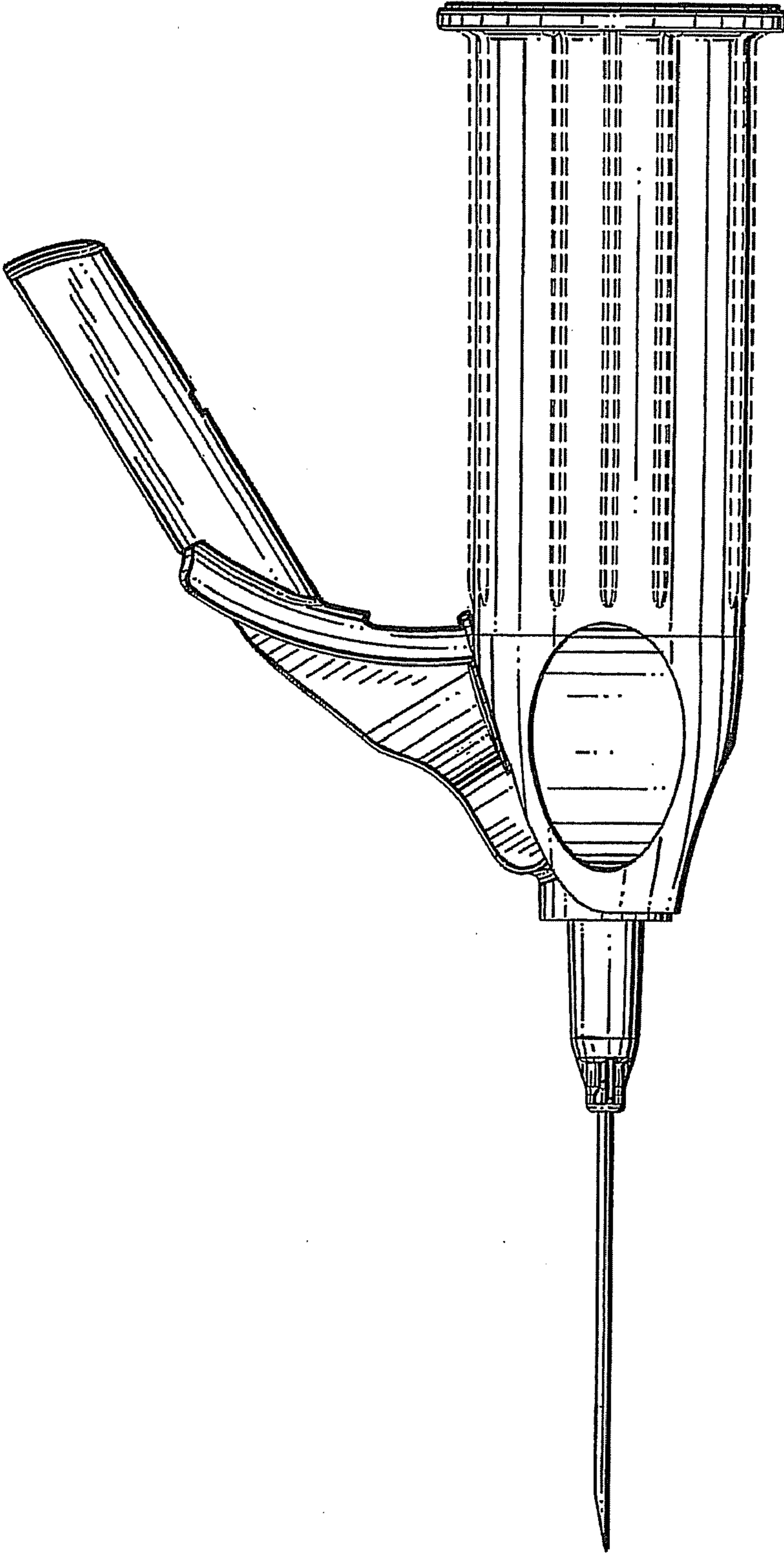

FIG.10

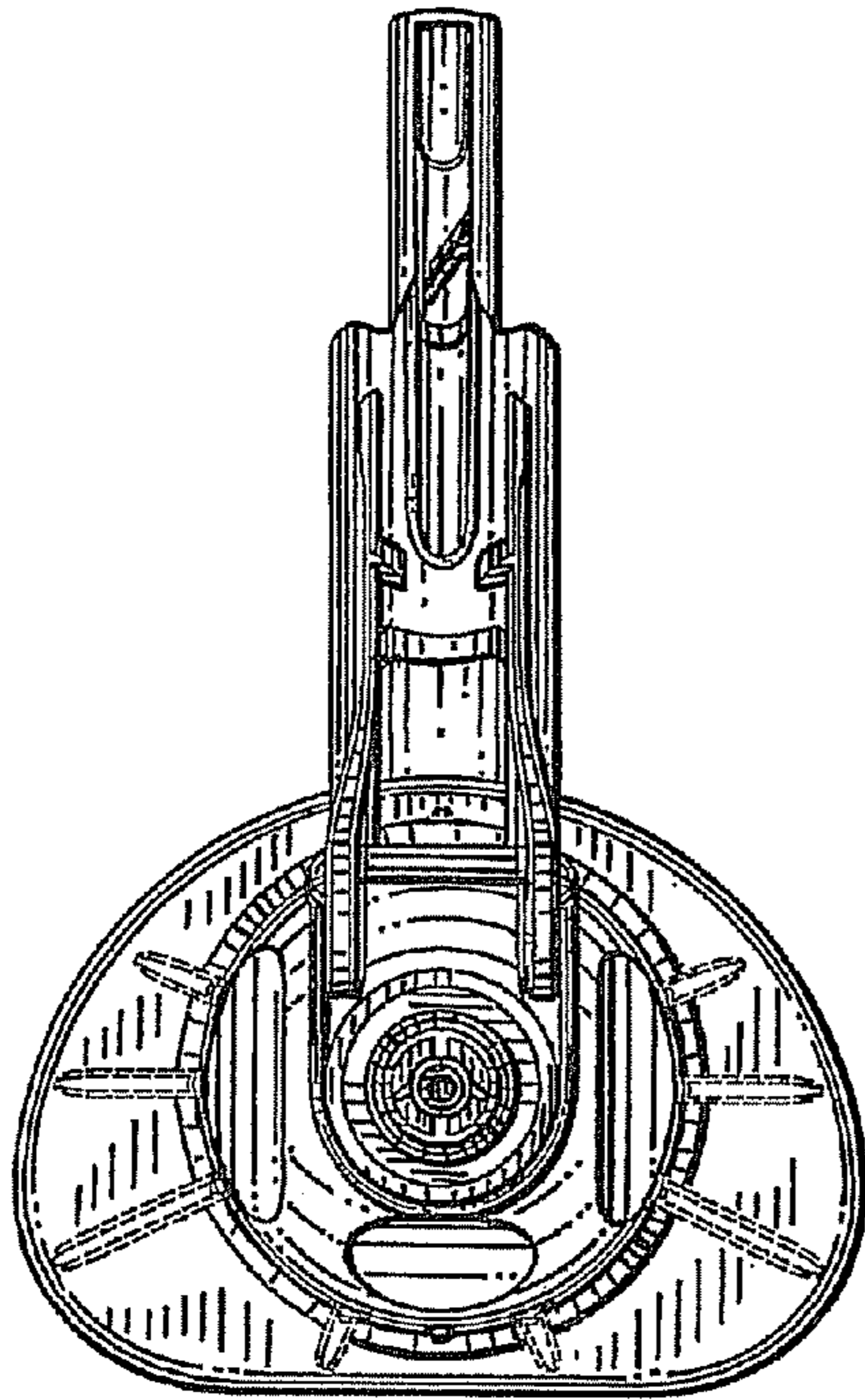

FIG. 11

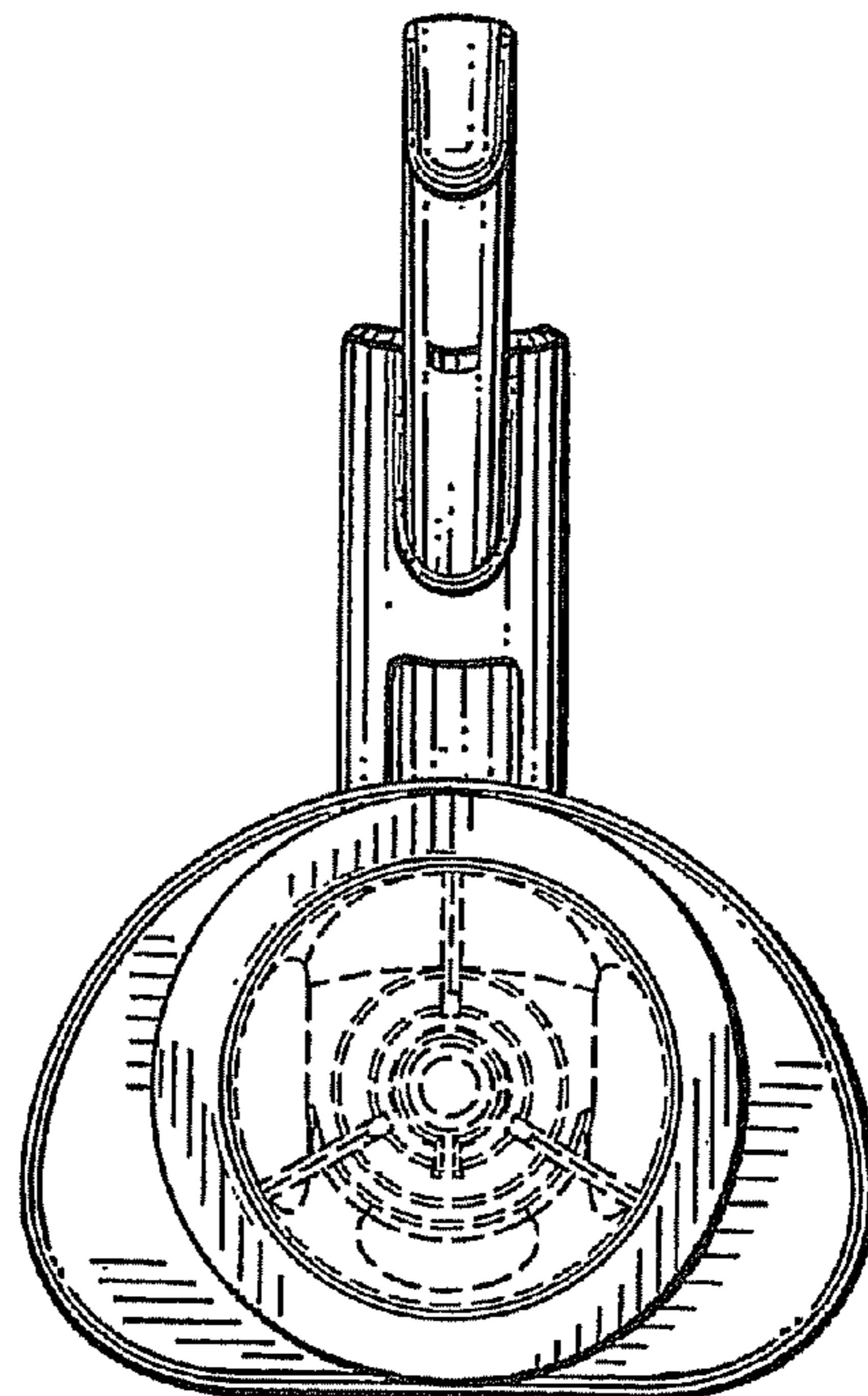

FIG. 12

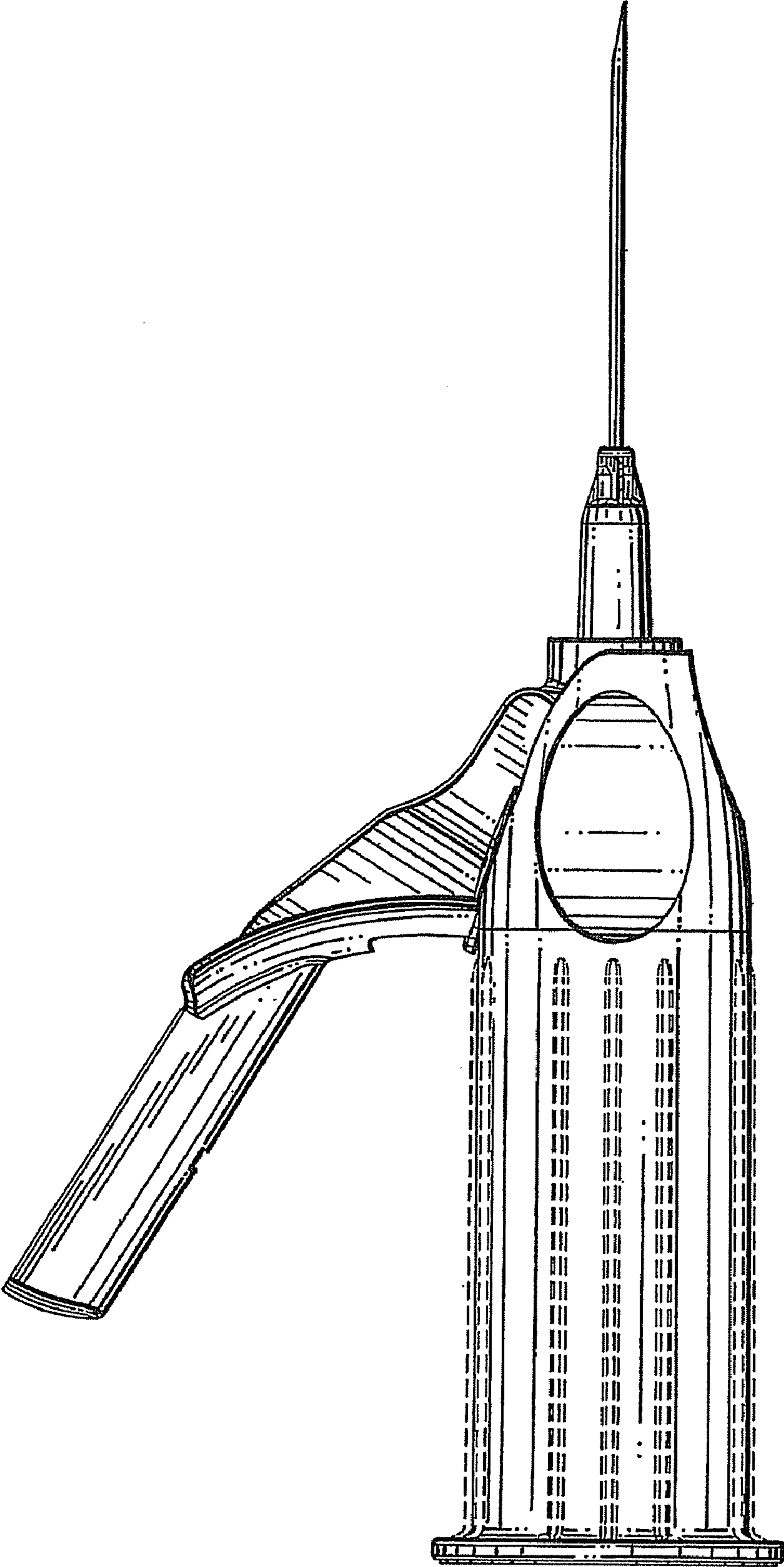

FIG.13

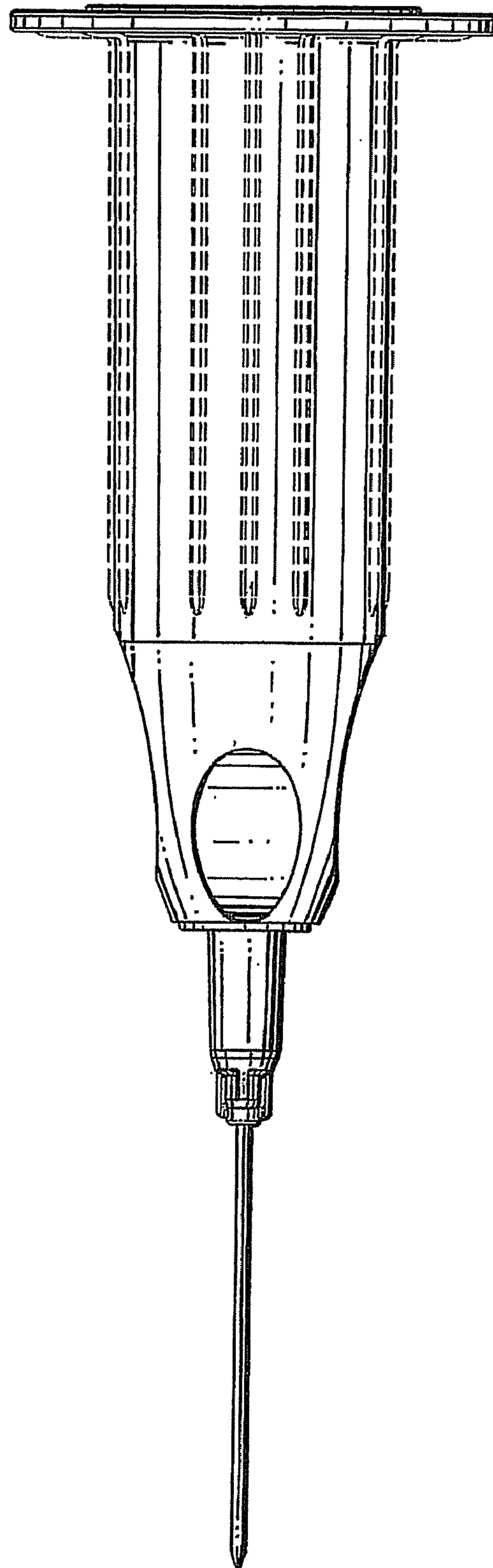

FIG. 14

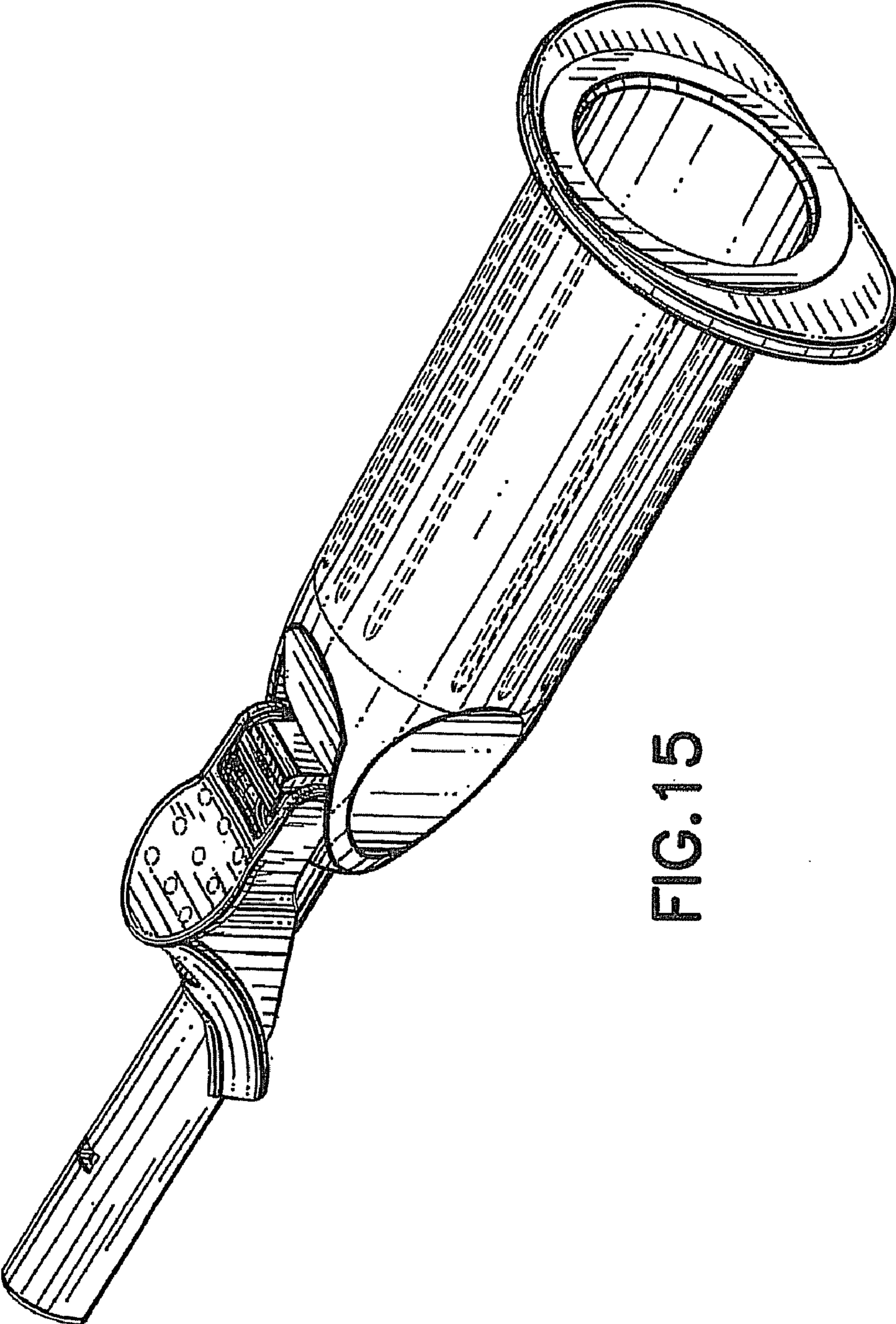

FIG. 15

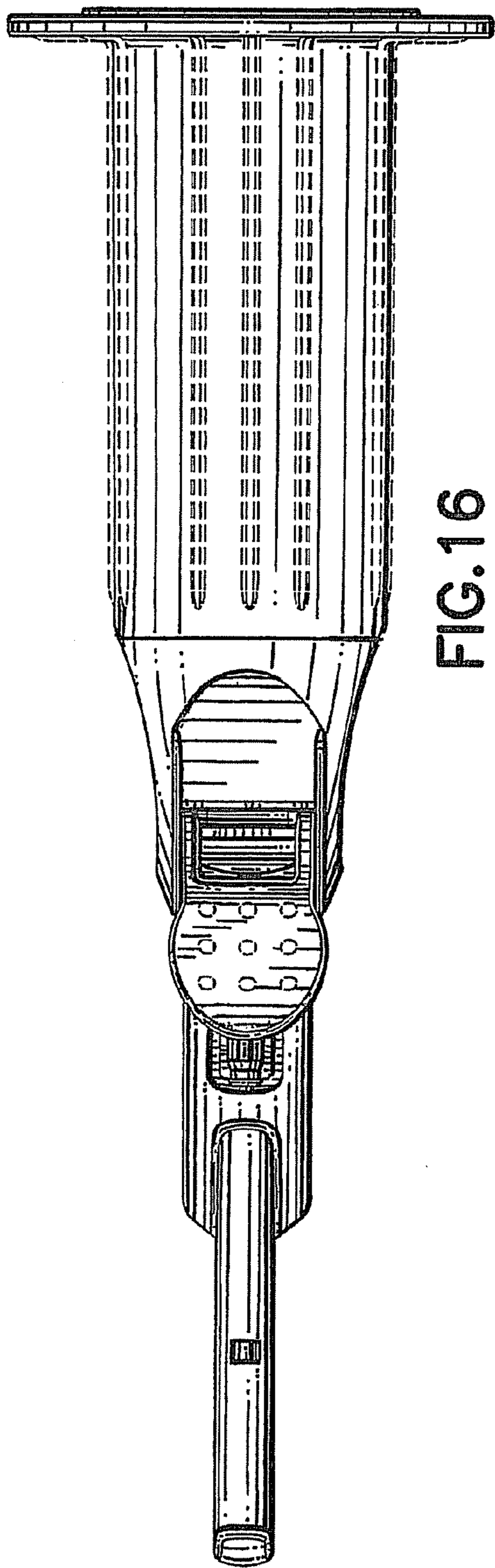

FIG. 16

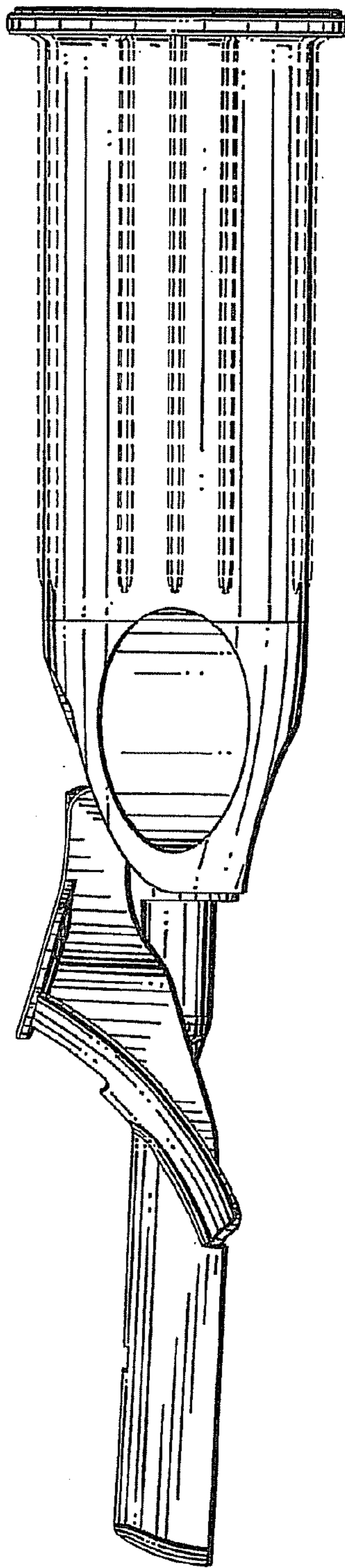

FIG. 17

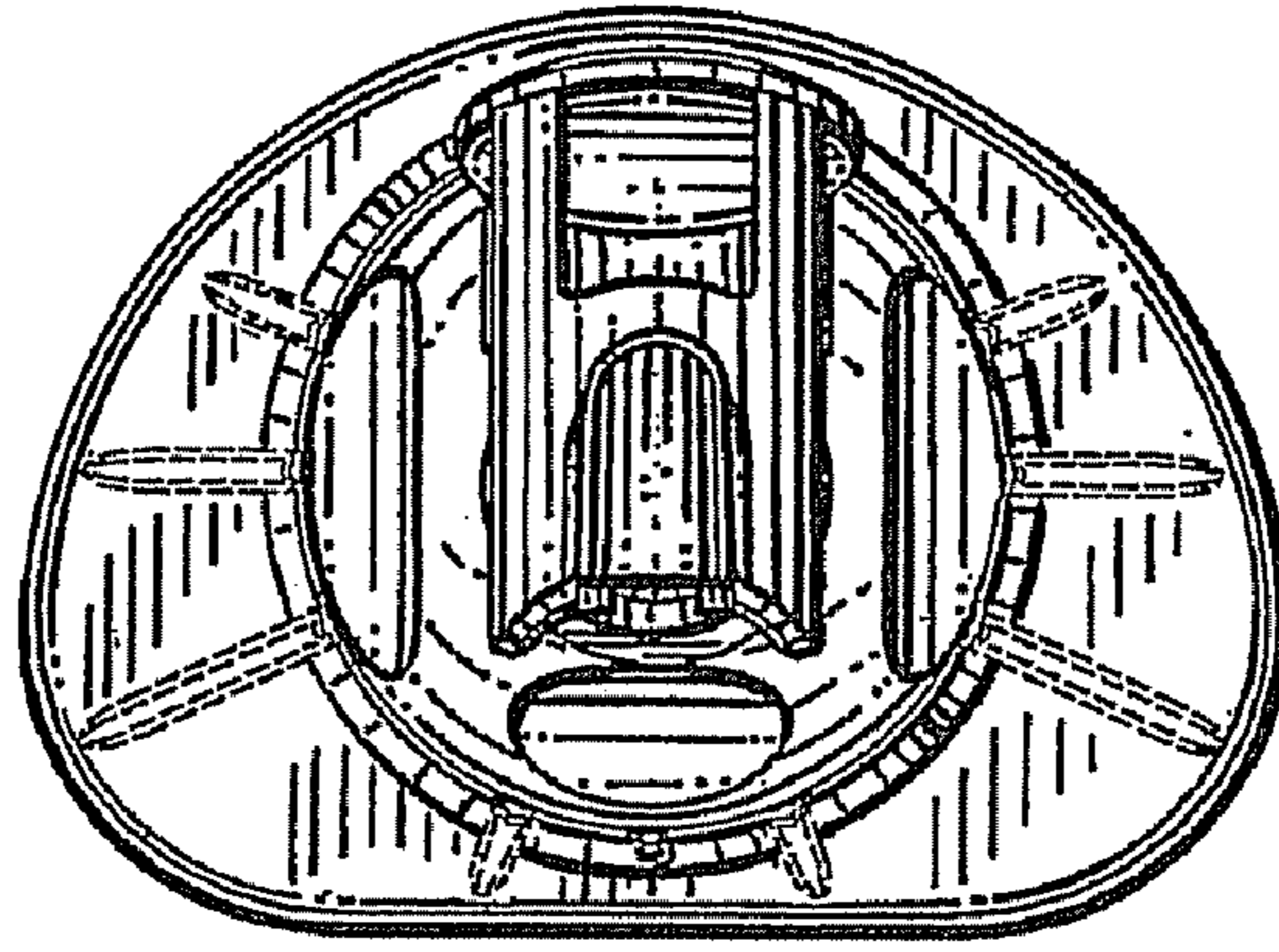

FIG. 18

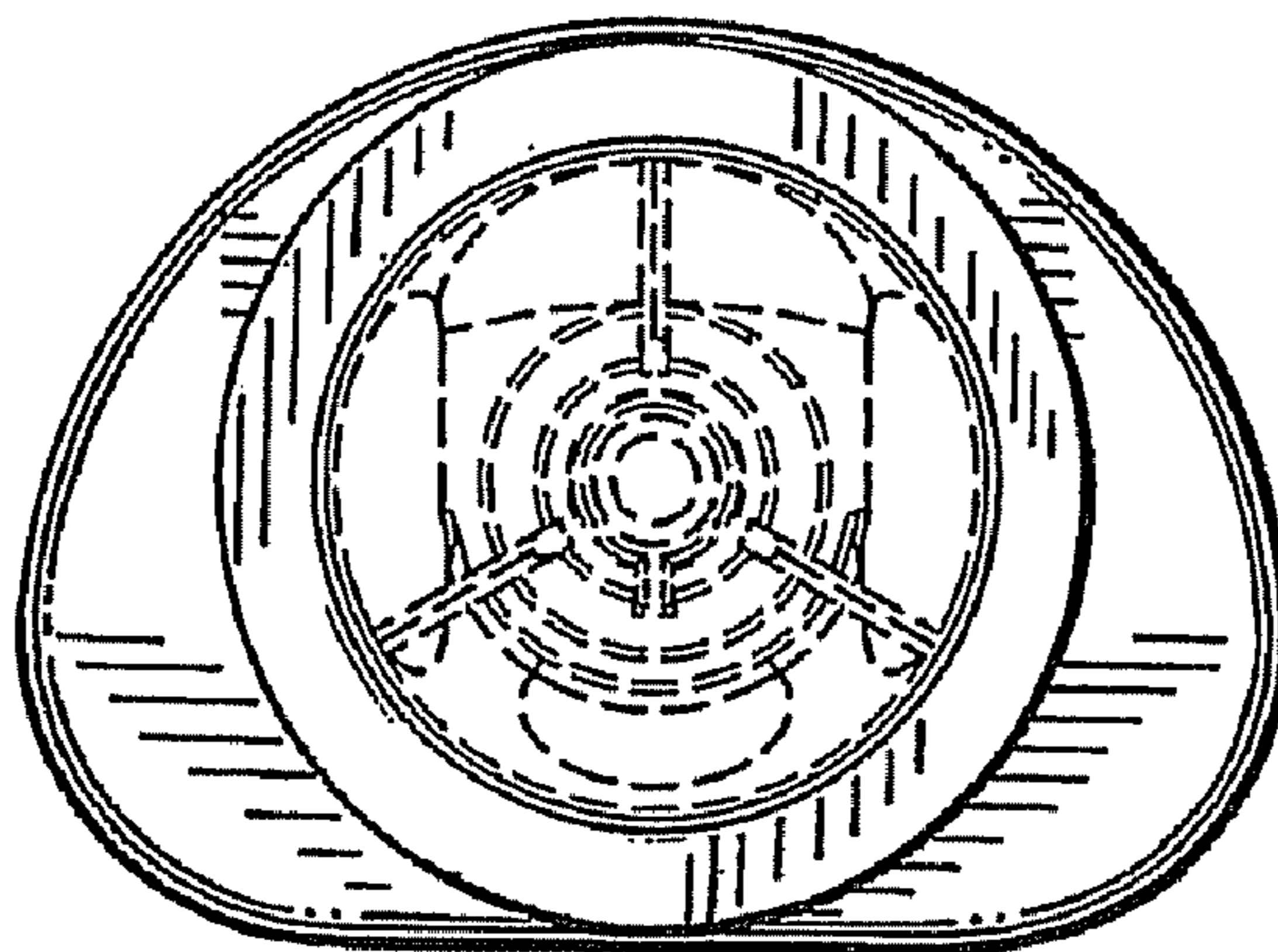

FIG. 19

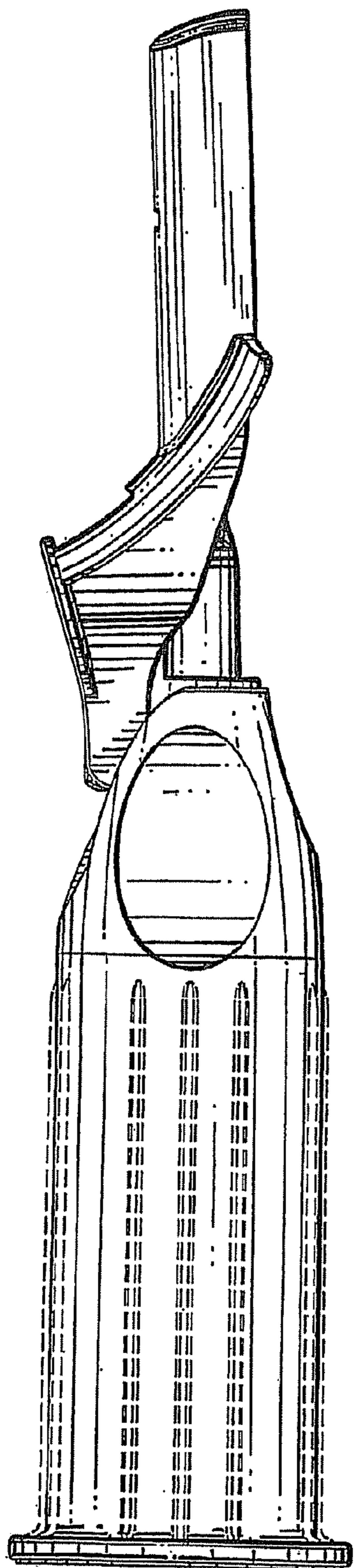

FIG. 20

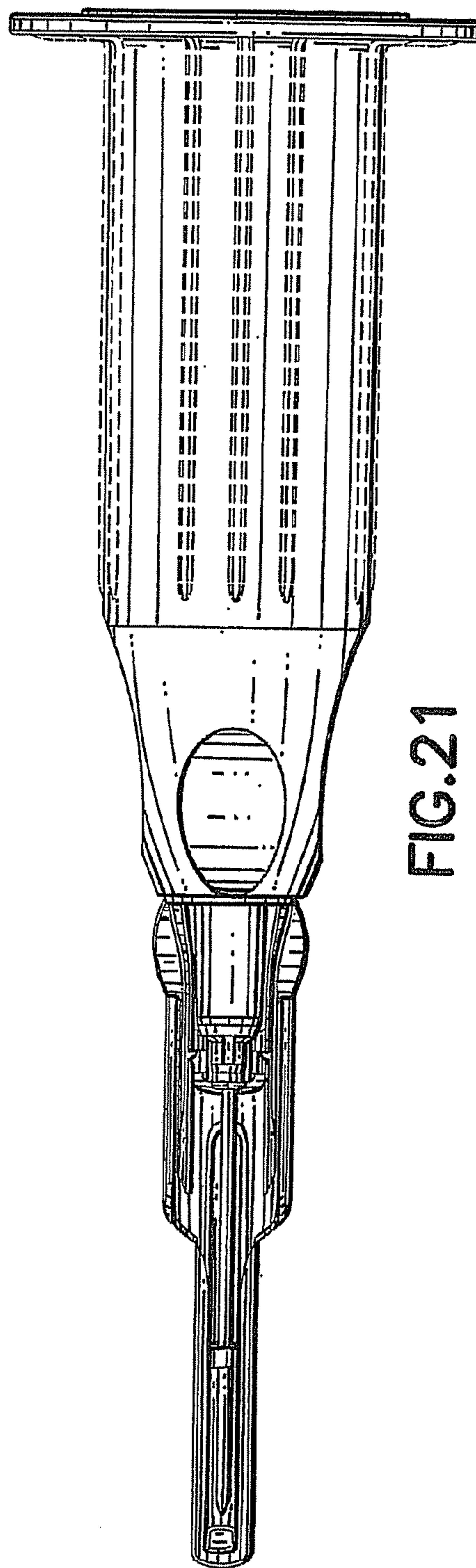

FIG. 21