



US00D604248S

(12) **United States Design Patent**
Sakamoto

(10) **Patent No.:** **US D604,248 S**

(45) **Date of Patent:** **** Nov. 17, 2009**

(54) **ELECTRICAL CONNECTOR**

(75) Inventor: **Tetsuma Sakamoto**, Tokyo (JP)

(73) Assignee: **Tyco Electronics AMP K.K.**,
Kanagawa-ken (JP)

(**) Term: **14 Years**

(21) Appl. No.: **29/327,913**

(22) Filed: **Nov. 14, 2008**

(30) **Foreign Application Priority Data**

May 16, 2008 (JP) 2008-012222

(51) **LOC (9) Cl.** **13-03**

(52) **U.S. Cl.** **D13/147**

(58) **Field of Classification Search** D13/133,
D13/146-147, 154, 184; 439/247-248, 350,
439/352, 354, 357, 540.1, 541.5, 607-610,
439/660, 677, 680, 682

See application file for complete search history.

(56) **References Cited**

U.S. PATENT DOCUMENTS

6,383,011 B2 * 5/2002 Chen 439/358
D517,992 S * 3/2006 Riku D13/147
D519,462 S * 4/2006 Kudo D13/147
D524,755 S * 7/2006 Kudo D13/147
D552,556 S * 10/2007 Sakamoto D13/147
D552,557 S * 10/2007 Sakamoto D13/147

D556,140 S * 11/2007 Sakamoto D13/147
D556,142 S * 11/2007 Kudo et al. D13/147
D570,783 S * 6/2008 So D13/147

FOREIGN PATENT DOCUMENTS

JP D1262049 2/2006
JP D1262264 2/2006

* cited by examiner

Primary Examiner—Daniel D Bui

(74) *Attorney, Agent, or Firm*—Barley Snyder LLC

(57) **CLAIM**

The ornamental design for an electrical connector, as shown and described.

DESCRIPTION

FIG. 1 is a front elevation view of an electrical connector, showing my new design;

FIG. 2 is a top plan view thereof;

FIG. 3 is a bottom plan view thereof;

FIG. 4 is a right side elevation view thereof;

FIG. 5 is a rear elevation view thereof;

FIG. 6 is a cross sectional view thereof; taken along line 6—6 in FIG. 1 thereof;

FIG. 7 is a bottom, front and right side perspective view thereof; and,

FIG. 8 is a bottom, rear and right side view.

1 Claim, 8 Drawing Sheets

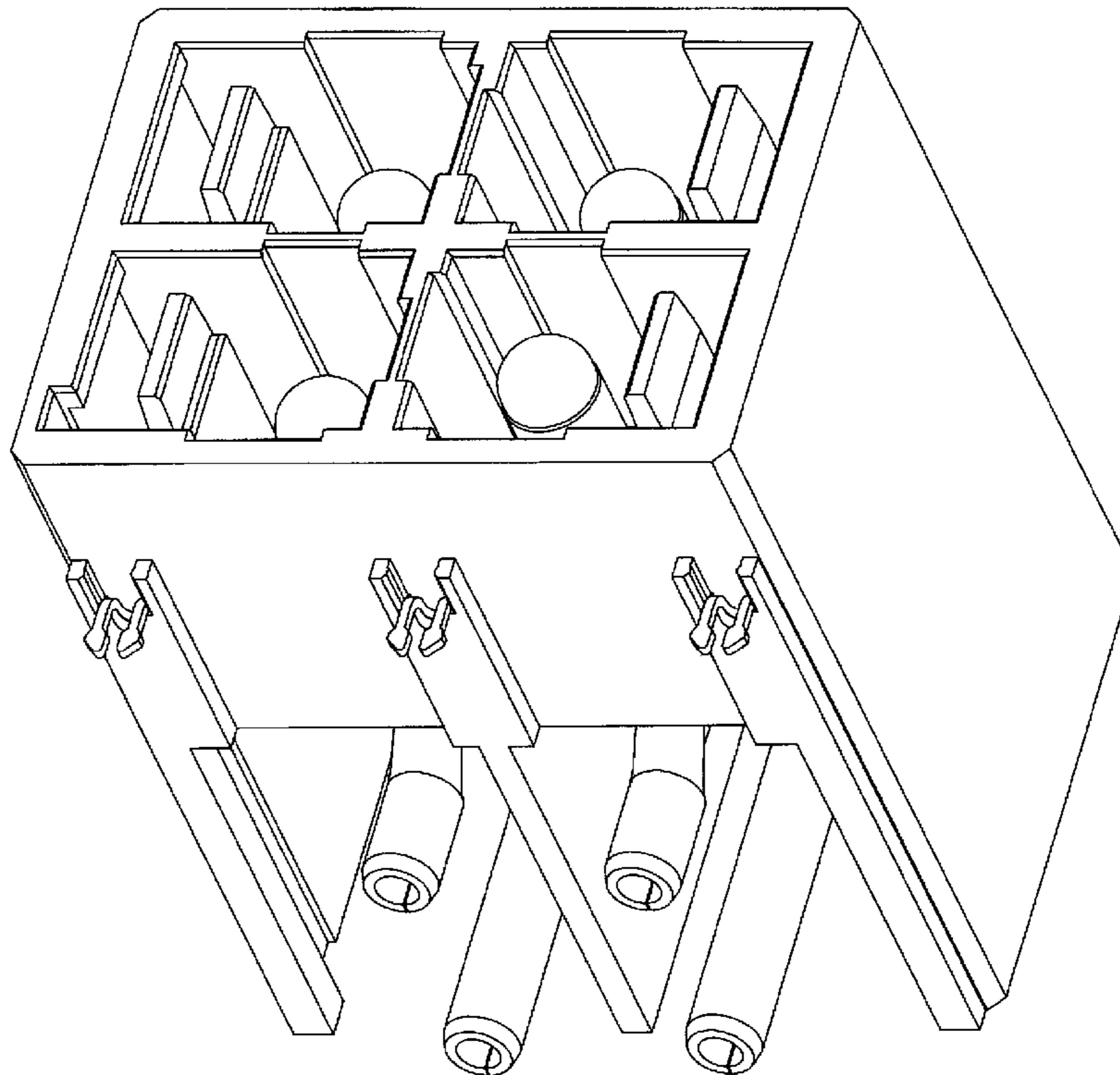

Figure 1

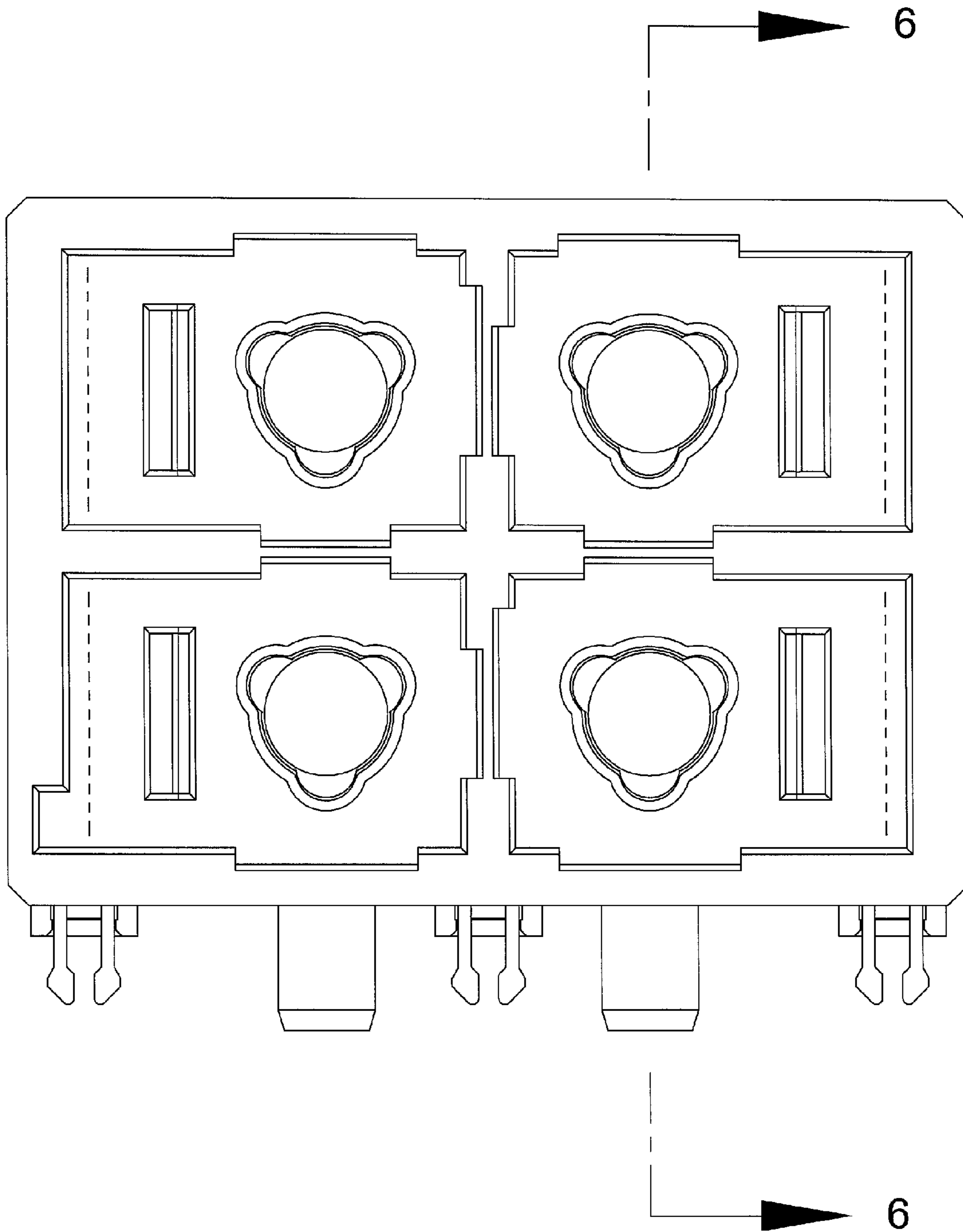

Figure 2

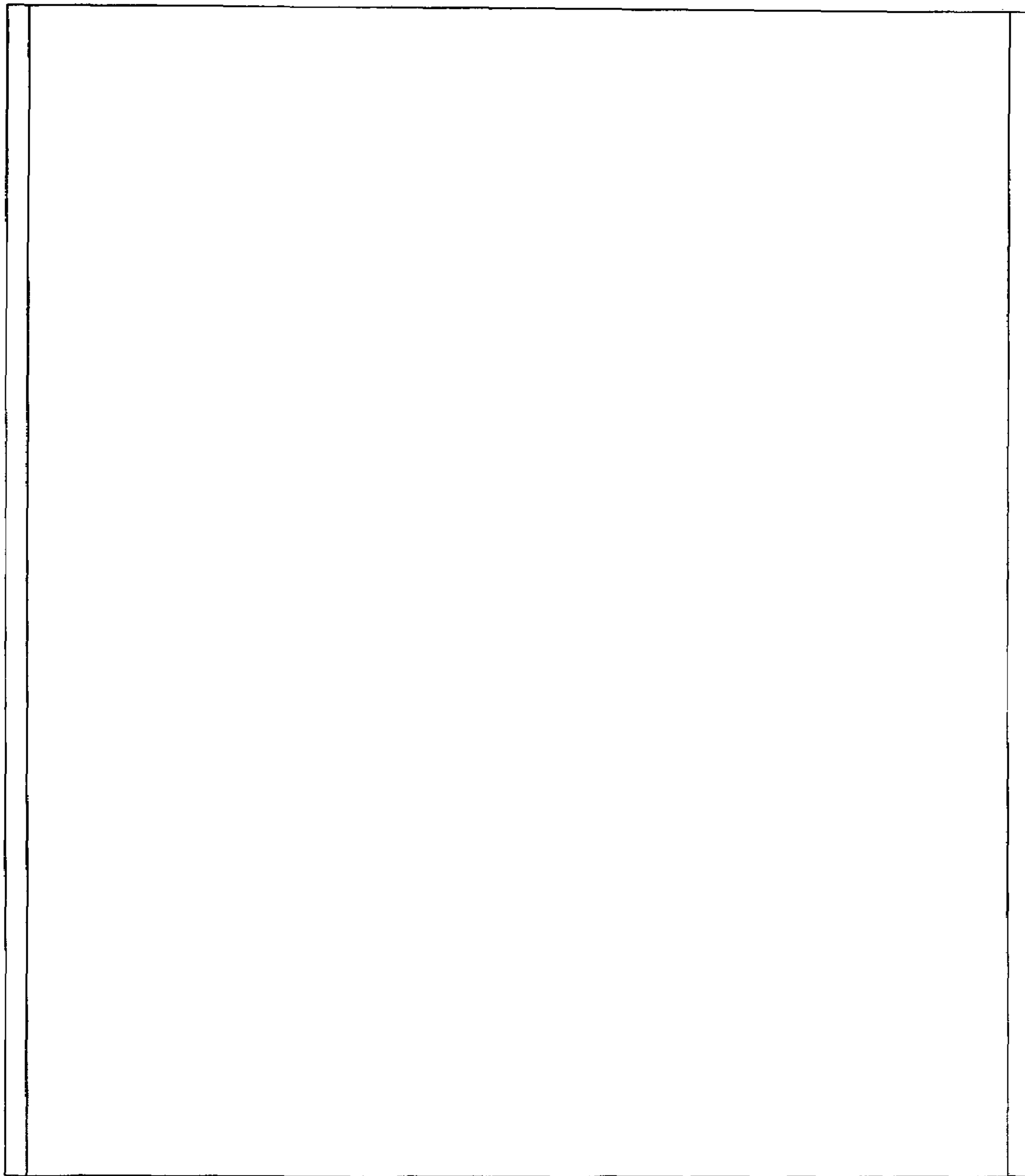

Figure 3

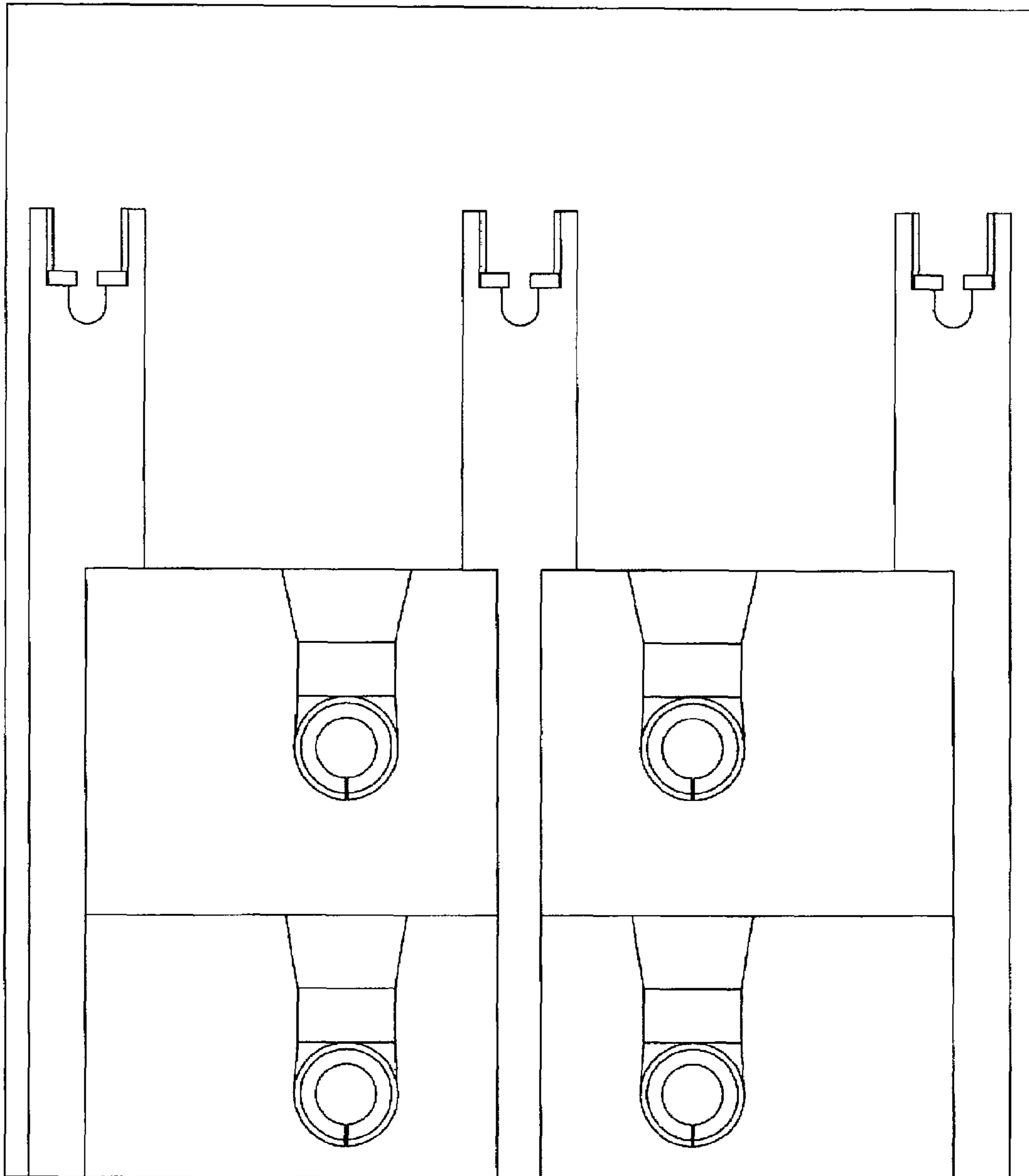

Figure 4

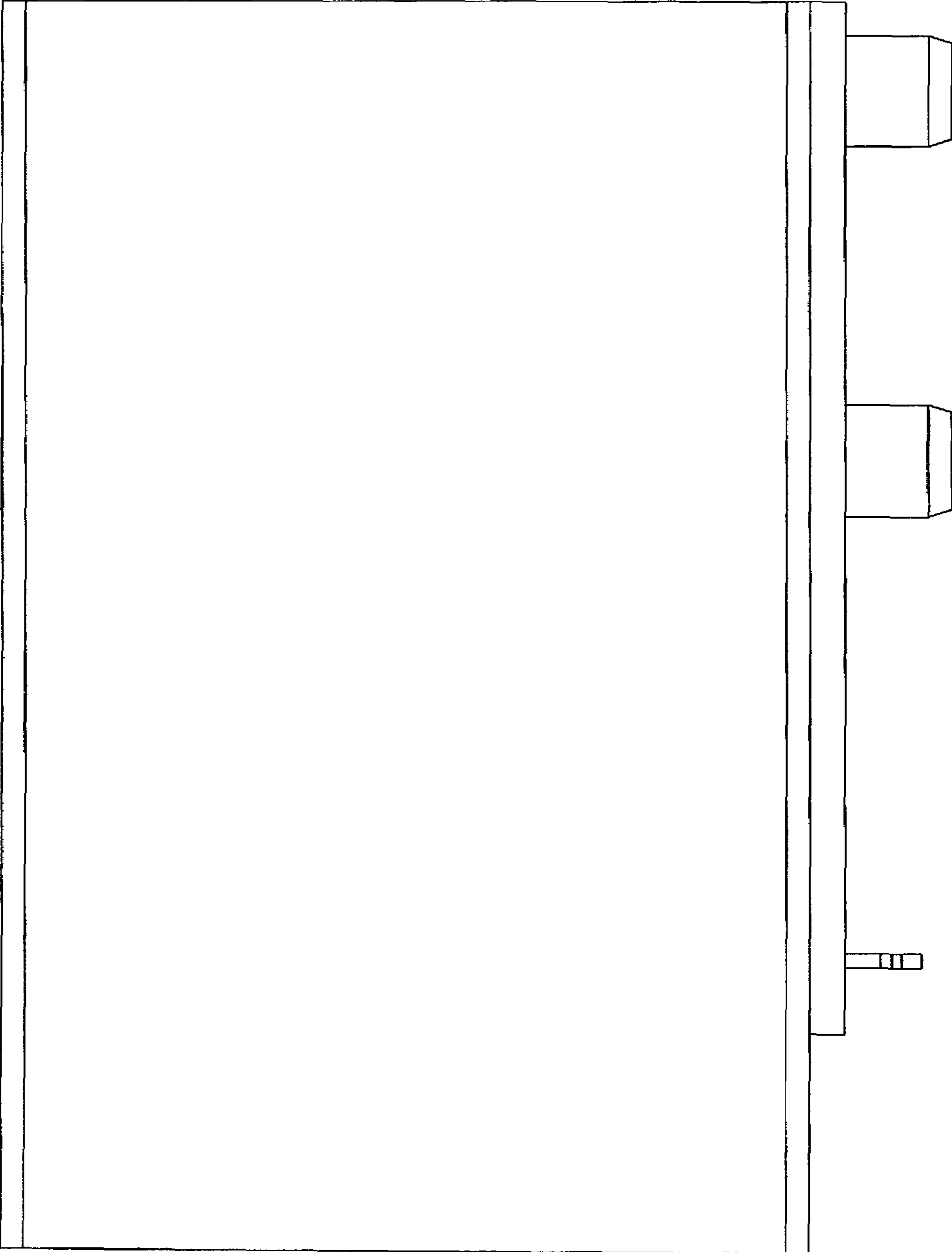
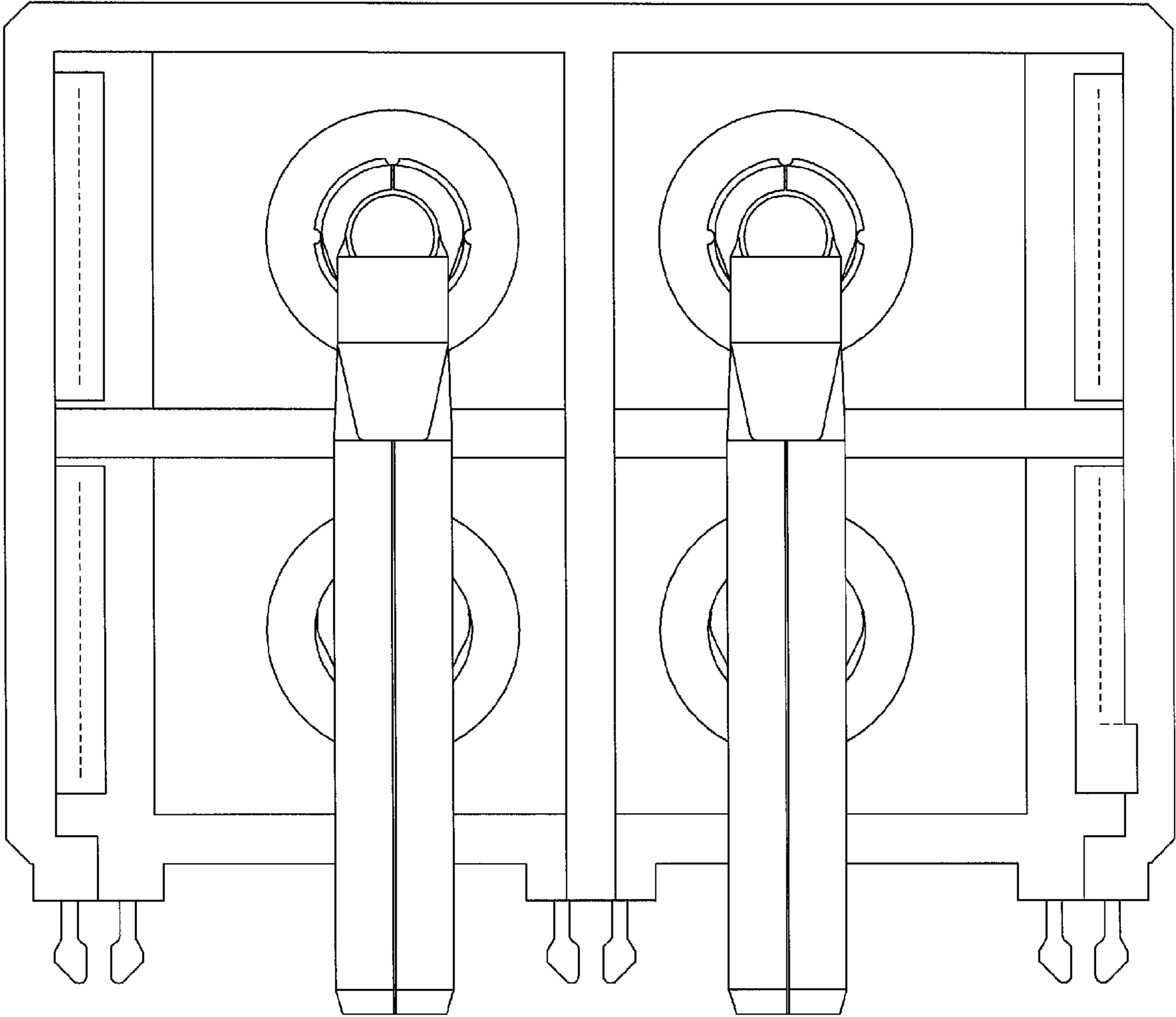

Figure 5



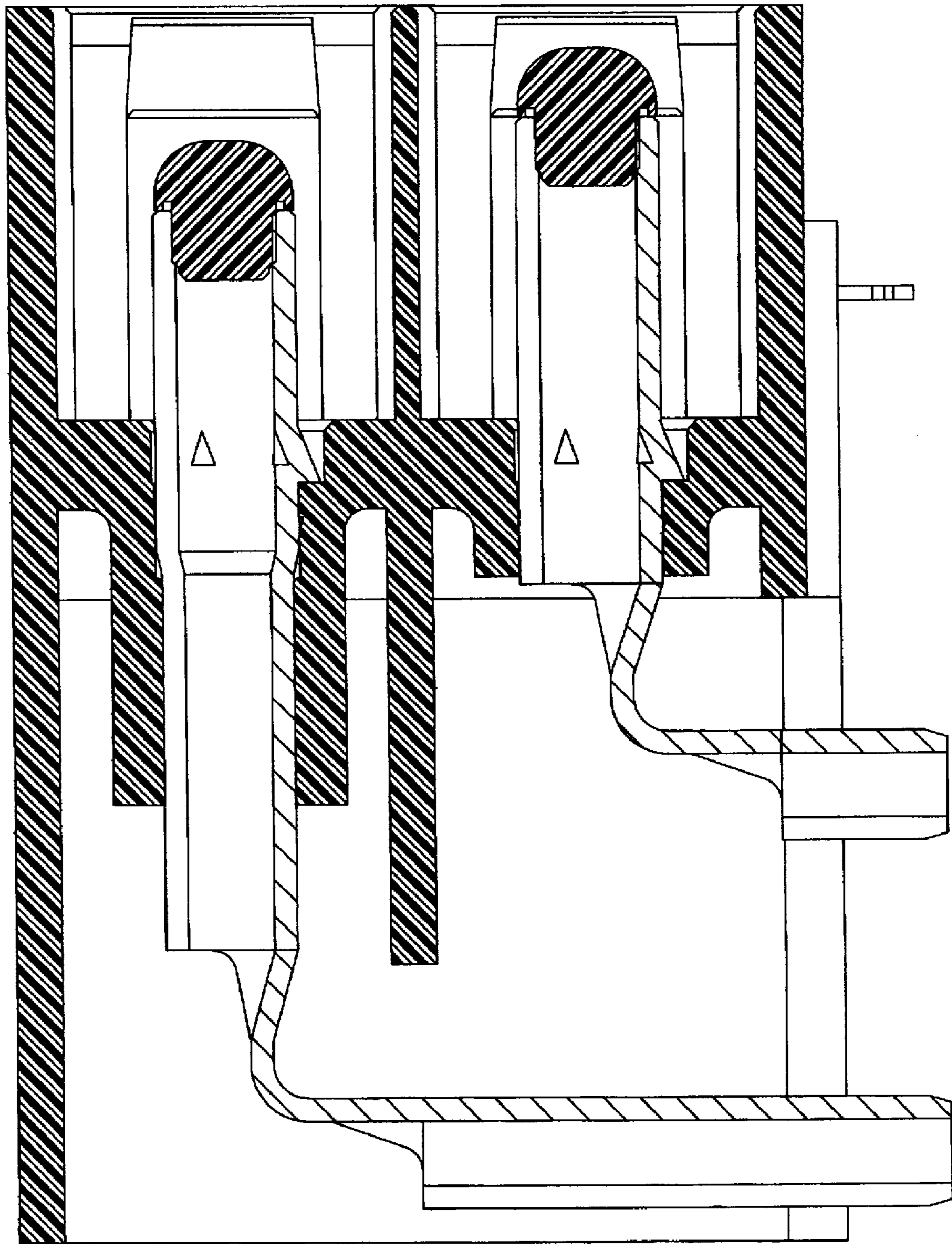

Figure 6

Figure 7

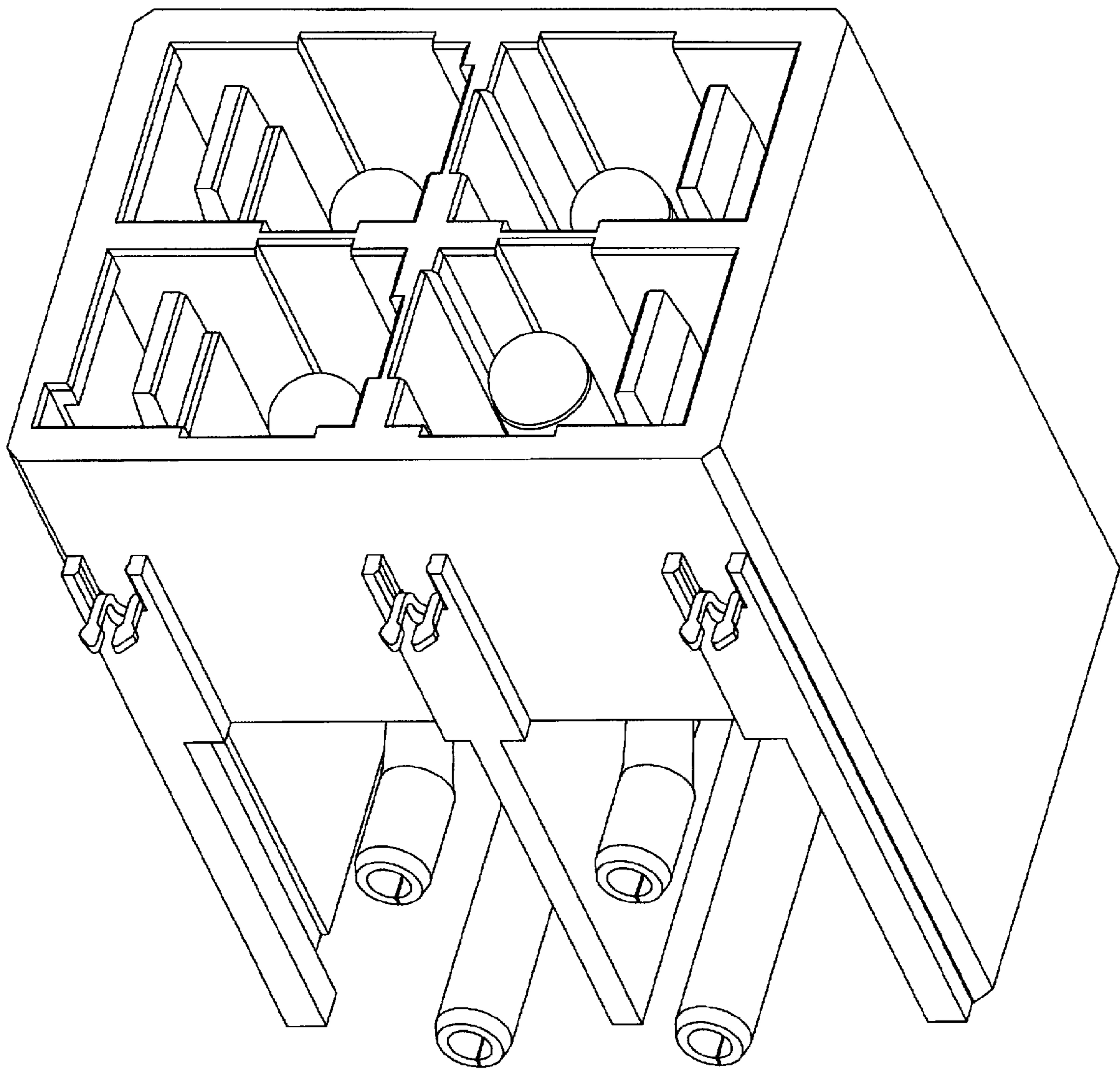

Figure 8

