



US00D603881S

(12) **United States Design Patent**
Tamplain, III et al.

(10) **Patent No.:** **US D603,881 S**

(45) **Date of Patent:** **** Nov. 10, 2009**

(54) **LOADER CAB**

(75) Inventors: **Thomas Wenceslas Tamplain, III**, Schriever, LA (US); **Jeffrey James Simoneaux**, Thibodaux, LA (US); **Marco Driest**, Thibodaux, LA (US); **Thomas C. Boe**, Cedar Falls, IA (US); **Richard Jon Smith**, Dubuque, IA (US); **Trace Dustin Landers**, Denver, IA (US); **Bruce Kevin Fryk**, Waverly, IA (US); **Timothy Scott Hunt**, Cedar Falls, IA (US); **Octavio Humberto Rodriguez Arellano**, Coah. (MX)

(73) Assignee: **Deere & Company**, Moline, IL (US)

(**) Term: **14 Years**

(21) Appl. No.: **29/332,337**

(22) Filed: **Feb. 13, 2009**

(51) **LOC (9) Cl.** **15-03**

(52) **U.S. Cl.** **D15/30**

(58) **Field of Classification Search** D15/10, D15/22-26, 28, 30, 31, 33; 180/89.11, 89.12, 180/89.13, 89.19, 900, 89.1; 296/190.01, 296/190.08, 210, 190, 202, 102
See application file for complete search history.

(56) **References Cited**

U.S. PATENT DOCUMENTS

- D245,697 S * 9/1977 Skyer et al. D15/30
- D245,698 S * 9/1977 Skyer et al. D15/30
- D258,823 S * 4/1981 Skyer et al. D15/30

- D275,199 S * 8/1984 Schmidt et al. D15/30
- D297,142 S * 8/1988 Funabashi et al. D15/30
- D297,329 S * 8/1988 Monehaie et al. D15/30
- D304,589 S * 11/1989 Lanphere et al. D15/30
- D424,580 S * 5/2000 Moehle et al. D15/23
- D531,646 S * 11/2006 McCarren et al. D15/30
- D535,310 S * 1/2007 Kuwae et al. D15/30
- D541,825 S * 5/2007 Pettersson D15/30
- D559,277 S * 1/2008 Tsujita et al. D15/24
- D561,205 S * 2/2008 Pettersson D15/30
- D571,378 S * 6/2008 Bernard et al. D15/30
- D579,028 S * 10/2008 VanDeVeer et al. D15/30

* cited by examiner

Primary Examiner—Stella M Reid

Assistant Examiner—Mark A Goodwin

(57) **CLAIM**

The ornamental design for a loader cab, as shown and described.

DESCRIPTION

FIG. 1 is a front left side perspective view of a loader cab showing our new design.

FIG. 2 is a top view of the loader cab design of FIG. 1.

FIG. 3 is a right side view of the loader cab design of FIG. 1.

FIG. 4 is a left side view of the loader cab design of FIG. 1.

FIG. 5 is a front view of the loader cab design of FIG. 1; and,

FIG. 6 is a rear view of the loader cab design of FIG. 1.

The broken line showing of a tractor is included for the purpose of illustrating environmental structure and forms no part of the claimed design.

1 Claim, 6 Drawing Sheets

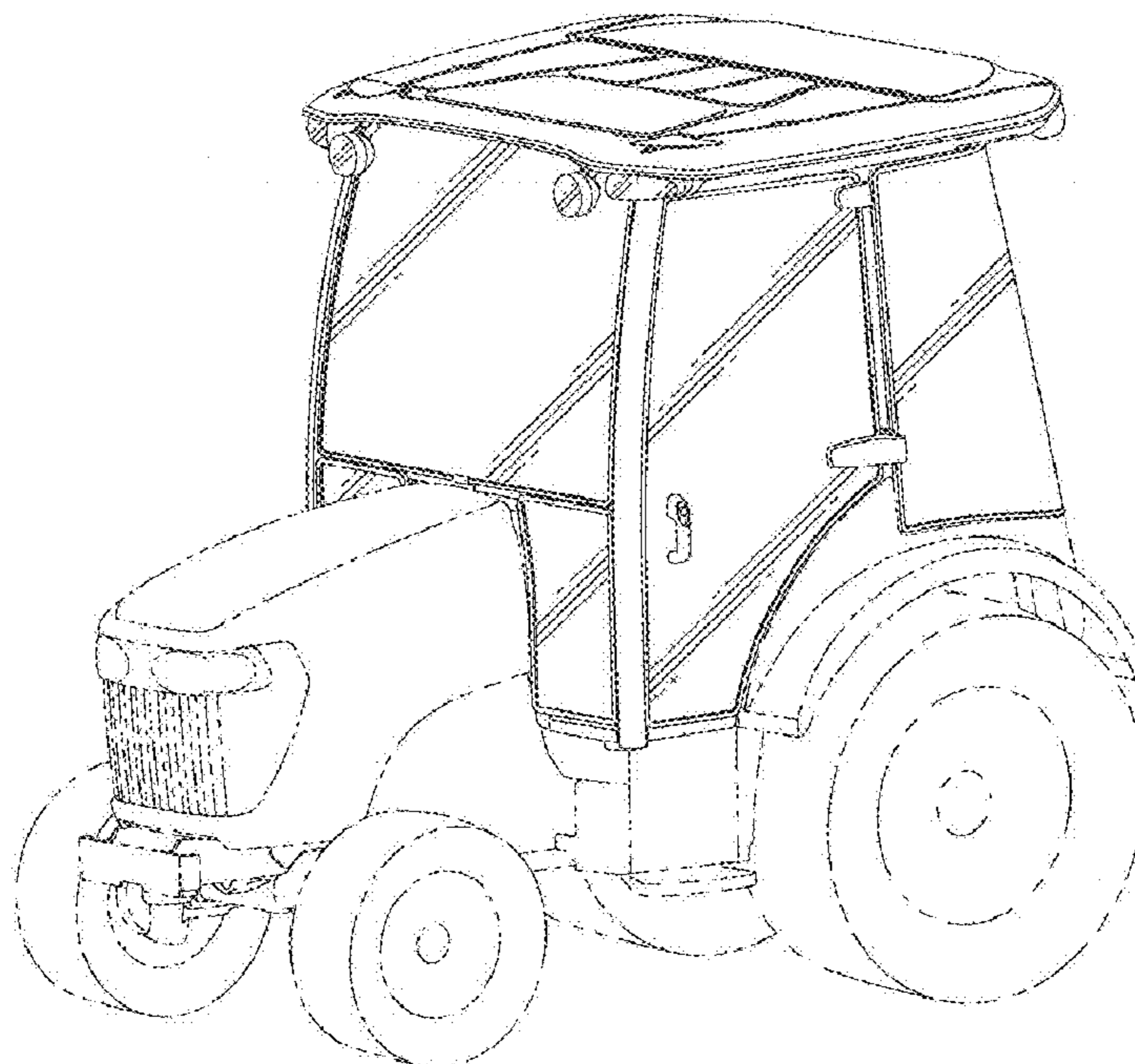

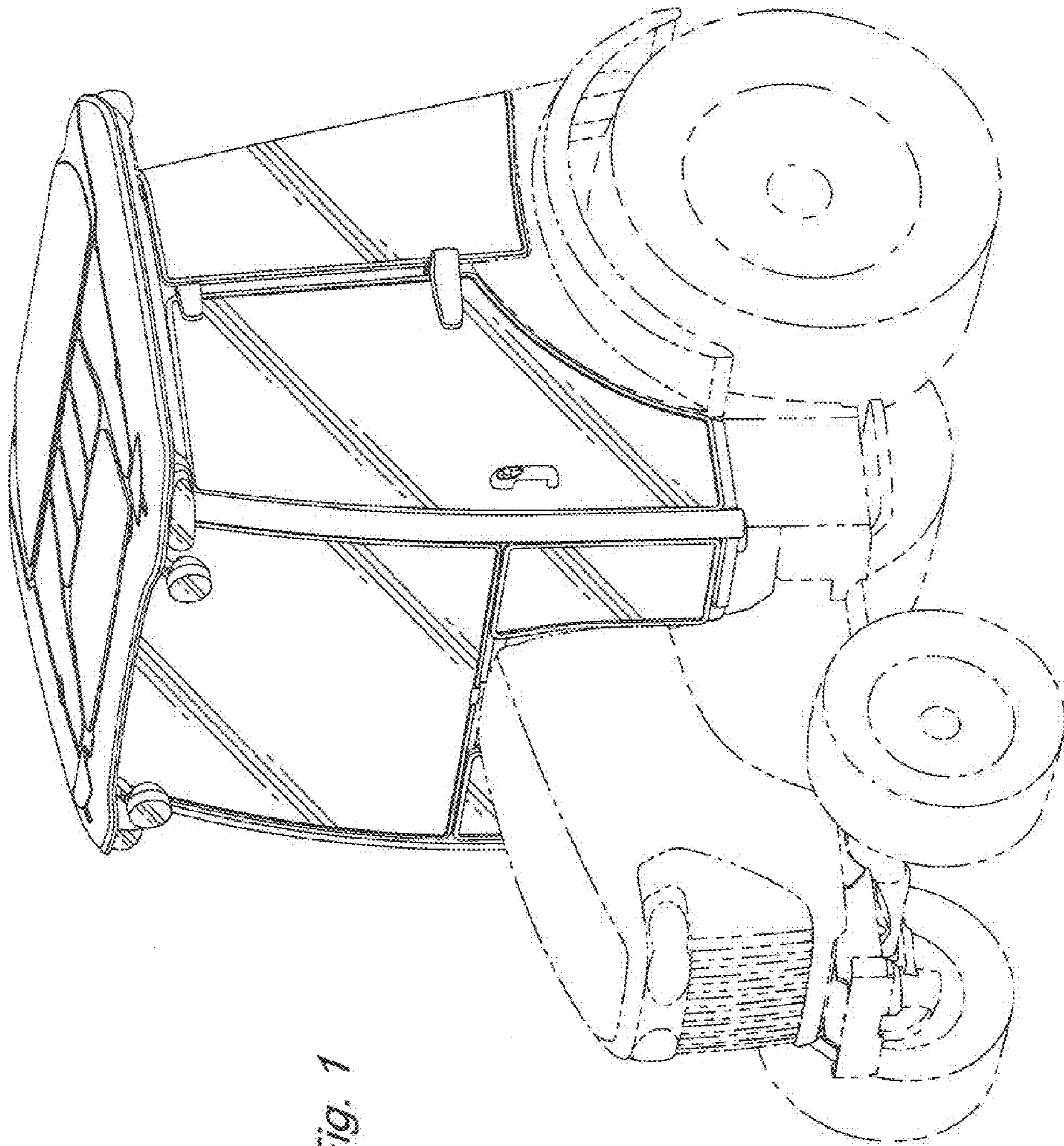

Fig. 1

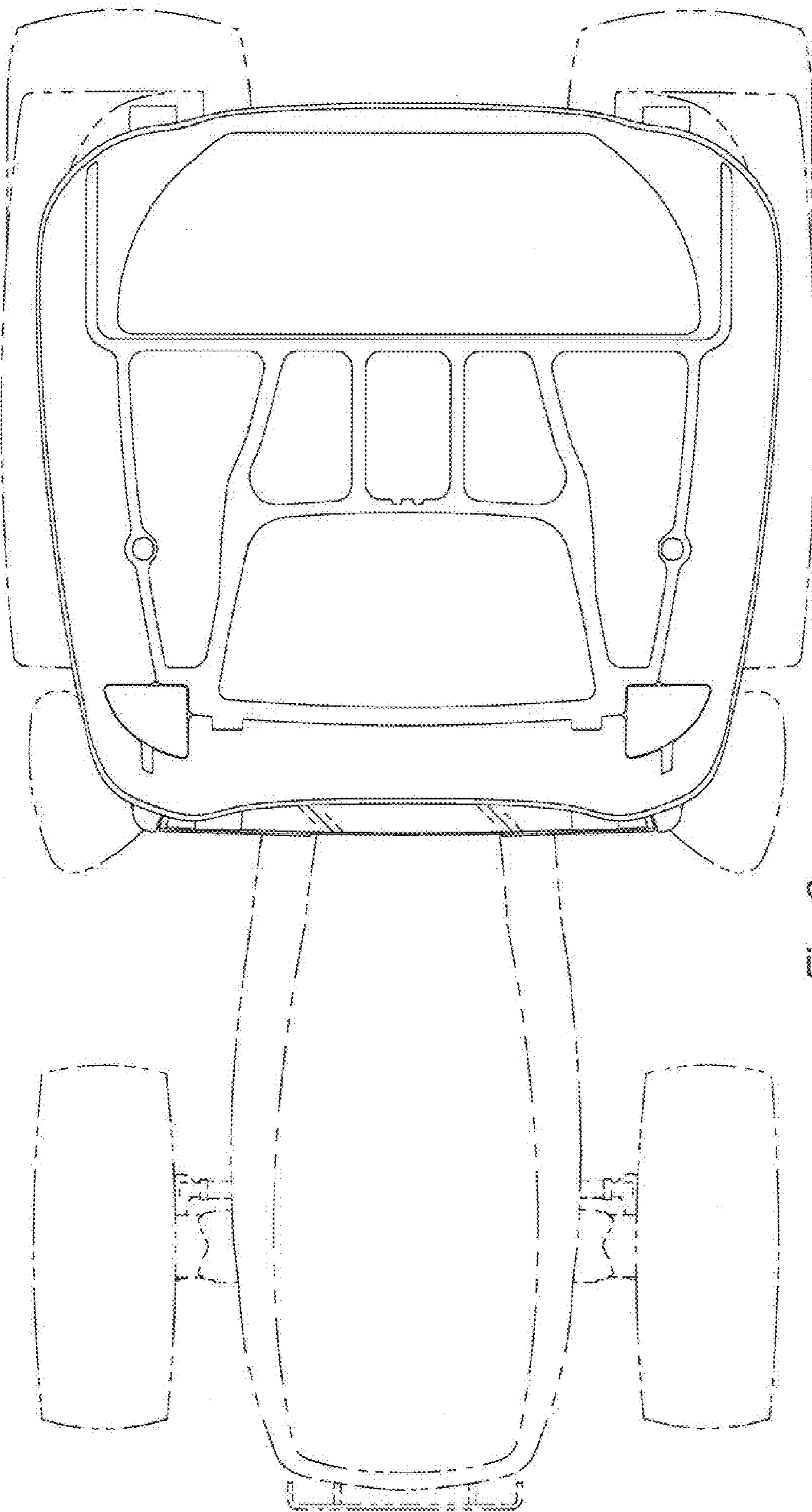

Fig. 2

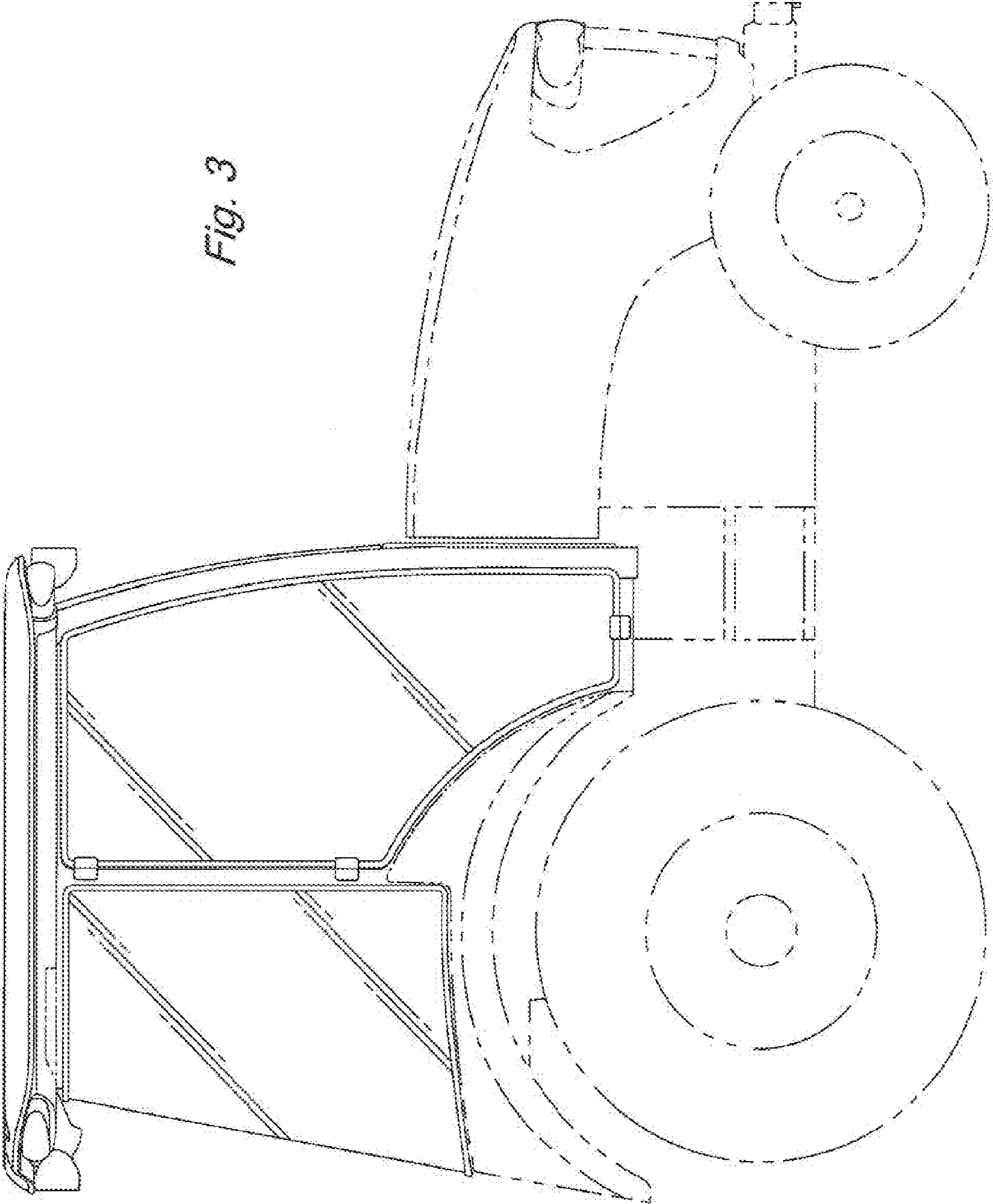

Fig. 3

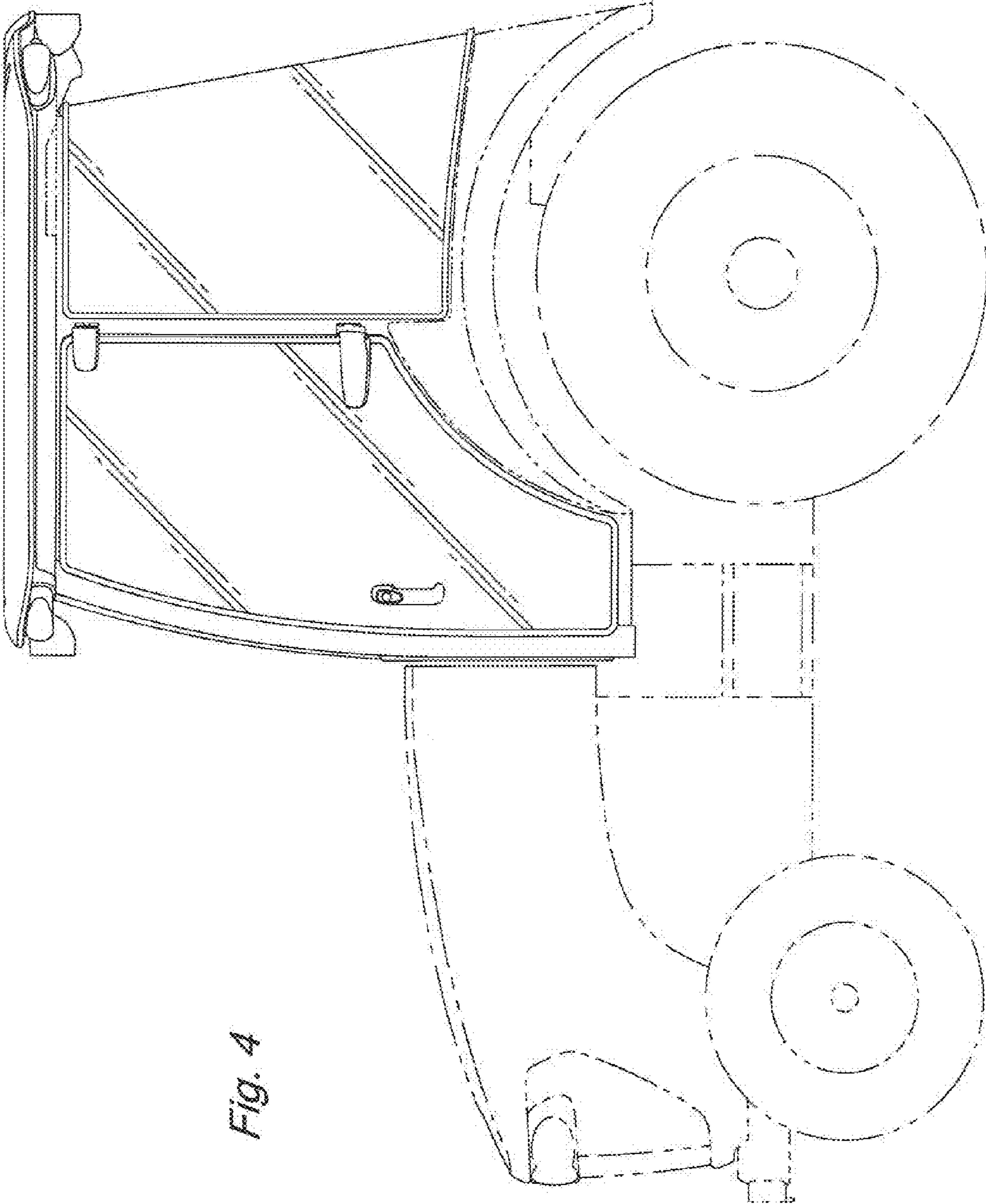

Fig. 4

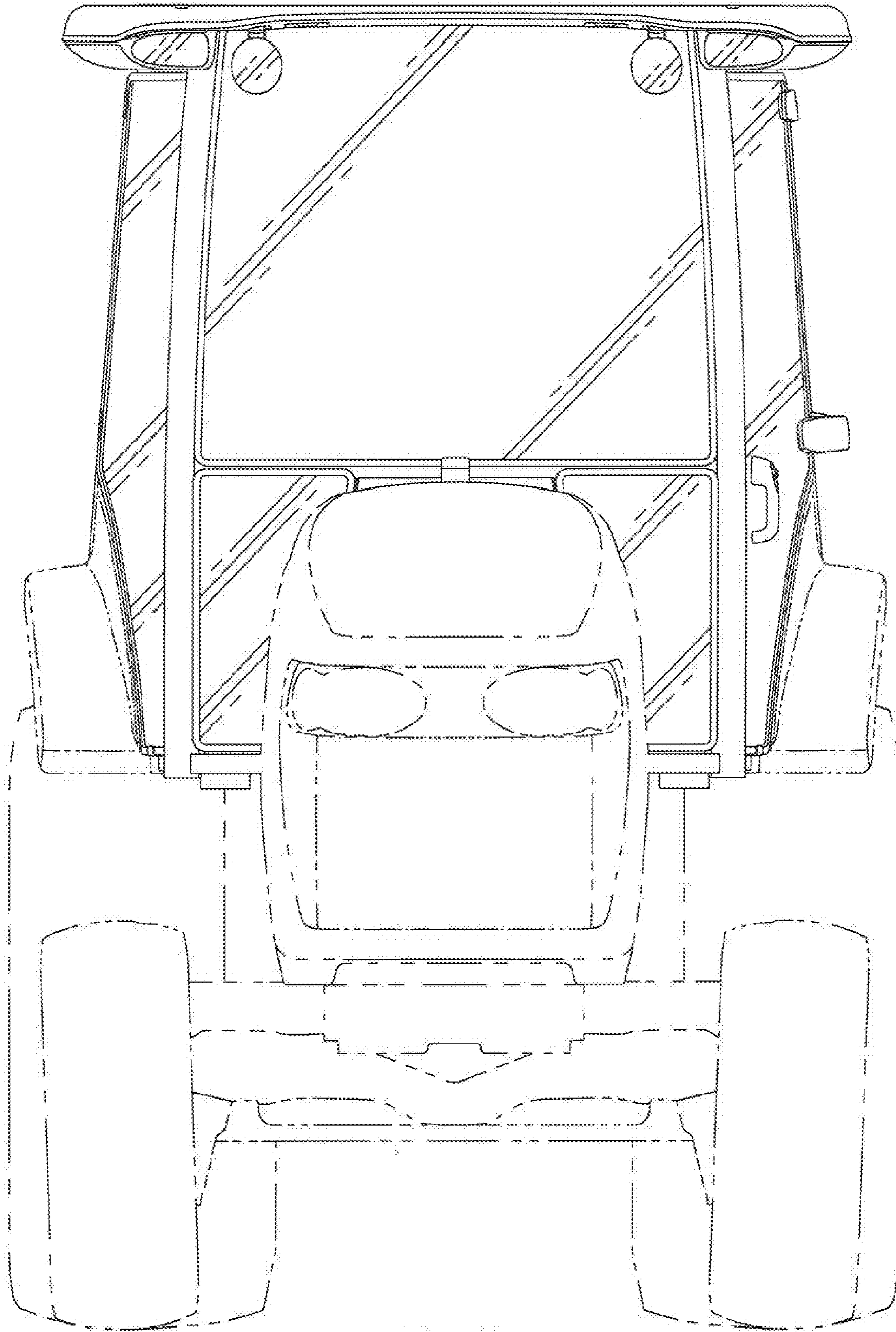

Fig. 5

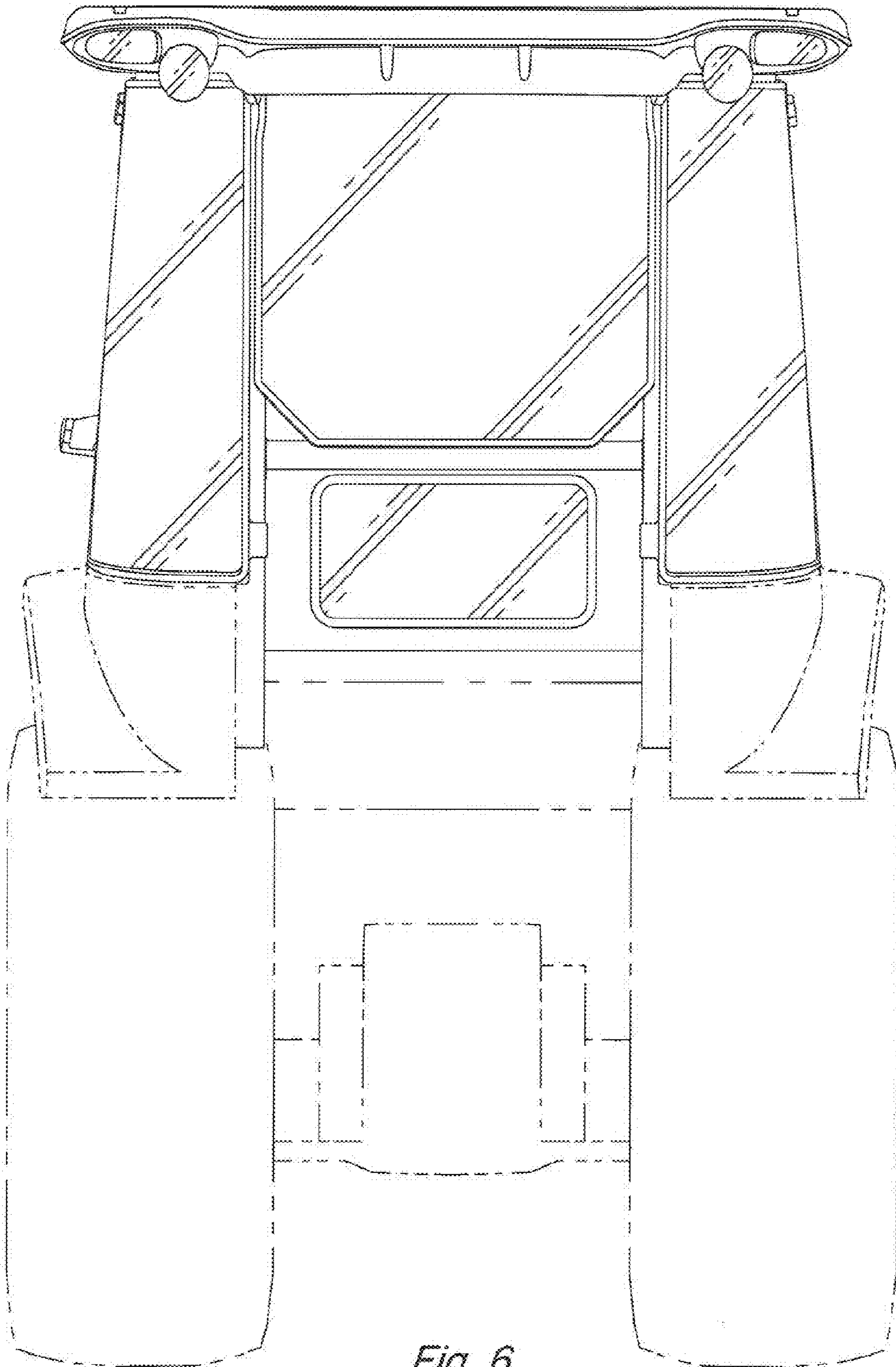

Fig. 6