



US00D603869S

(12) **United States Design Patent**
Beatty

(10) **Patent No.:** **US D603,869 S**

(45) **Date of Patent:** **** Nov. 10, 2009**

(54) **DRIVESHAFT TUNNEL**

(76) **Inventor:** **Ernest Dean Beatty**, 3764 Zink Rd.,
Carleton, MI (US) 48117

(**) **Term:** **14 Years**

(21) **Appl. No.:** **29/319,737**

(22) **Filed:** **Jun. 13, 2008**

(51) **LOC (9) Cl.** **15-01**

(52) **U.S. Cl.** **D15/5**

(58) **Field of Classification Search** D15/1,
D15/3, 5, 148; 248/250; 74/609

See application file for complete search history.

(56) **References Cited**

U.S. PATENT DOCUMENTS

926,800	A	7/1909	Young	
1,236,768	A	8/1917	Sarmiento	
D59,358	S	10/1921	Kanev	
2,612,763	A *	10/1952	Hansen	464/176
2,775,905	A *	1/1957	Jackson	74/609
3,455,409	A	7/1969	Clark	
3,981,376	A	9/1976	Kluge, Jr.	
D244,020	S	4/1977	Hanson et al.	
D252,576	S	8/1979	Frey	
4,324,533	A	4/1982	Schroeder et al.	
5,193,415	A	3/1993	Massel	
5,711,710	A	1/1998	Brisk	
5,906,347	A	5/1999	Noland	
D463,450	S *	9/2002	Beckenbach et al.	D15/5
D579,842	S *	11/2008	Ren	D12/194

FOREIGN PATENT DOCUMENTS

FR 2798448 3/2001

* cited by examiner

Primary Examiner—Lisa P Lichtenstein

(74) *Attorney, Agent, or Firm*—Gifford, Krass, Sprinkle,
Anderson & Citkowski, P.C.

(57) **CLAIM**

I claim the ornamental design for a driveshaft tunnel, as shown and described.

DESCRIPTION

FIG. 1 is a perspective side view of a driveshaft tunnel shaped according to an embodiment of the design;

FIG. 2 is an end view of the design;

FIG. 3 is a side view of the design;

FIG. 4 is a top view of the design;

FIG. 5 is an opposite side view of the design;

FIG. 6 is a bottom view of the design.

FIG. 7 is a perspective side view of a driveshaft tunnel shaped according to another embodiment of the design;

FIG. 8 is an end view of the embodiment of the design shown in FIG. 7;

FIG. 9 is a side view of the embodiment of the design shown in FIG. 7;

FIG. 10 is a top view of the embodiment of the design shown in FIG. 7;

FIG. 11 is an opposite side of the embodiment of the design shown in FIG. 7; and,

FIG. 12 is a bottom view of the embodiment of the design shown in FIG. 7.

The broken line showing of portions of the driveshaft tunnel is included for the purpose of illustrating environmental structure and forms no part of the claimed design.

1 Claim, 4 Drawing Sheets

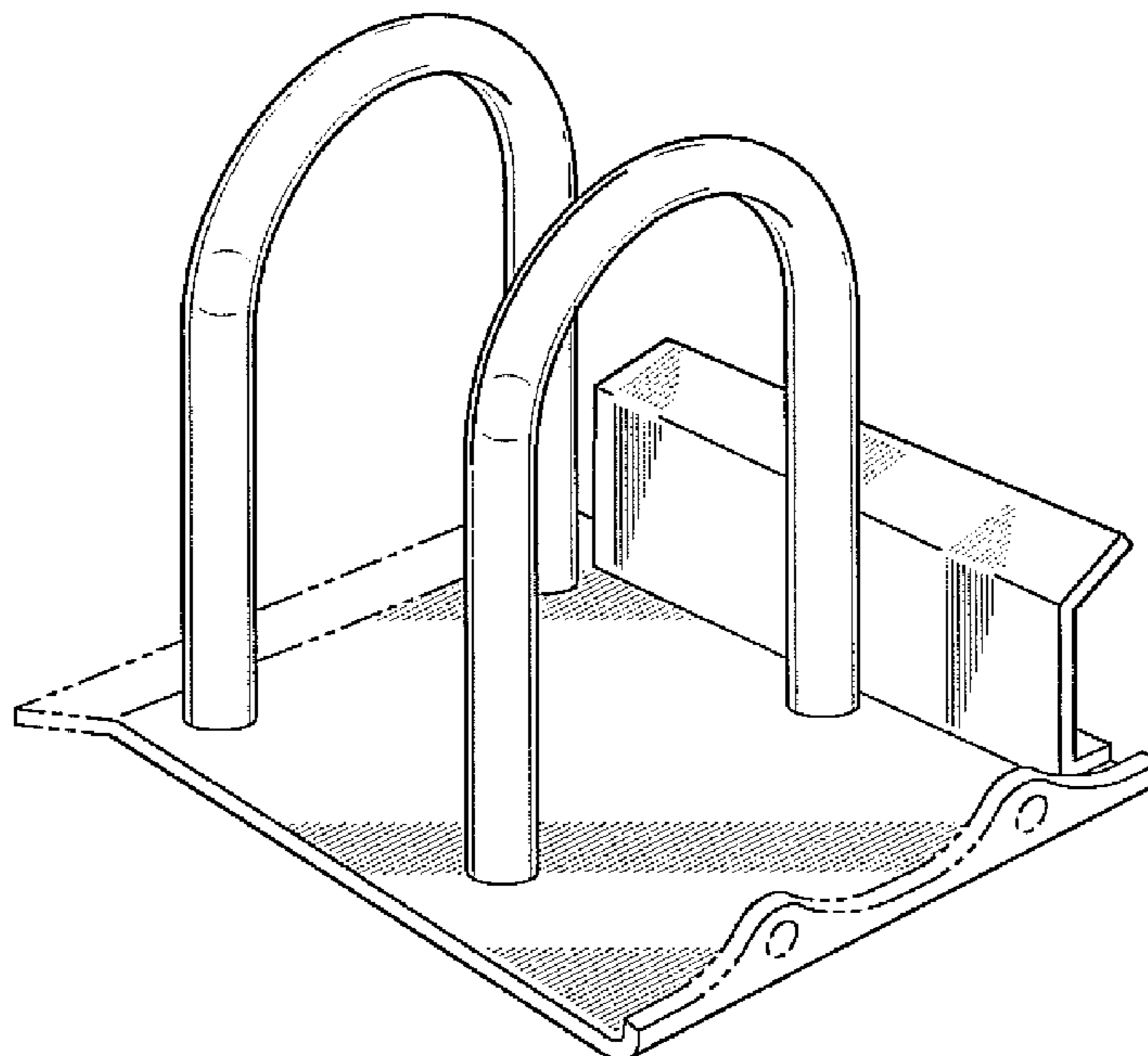

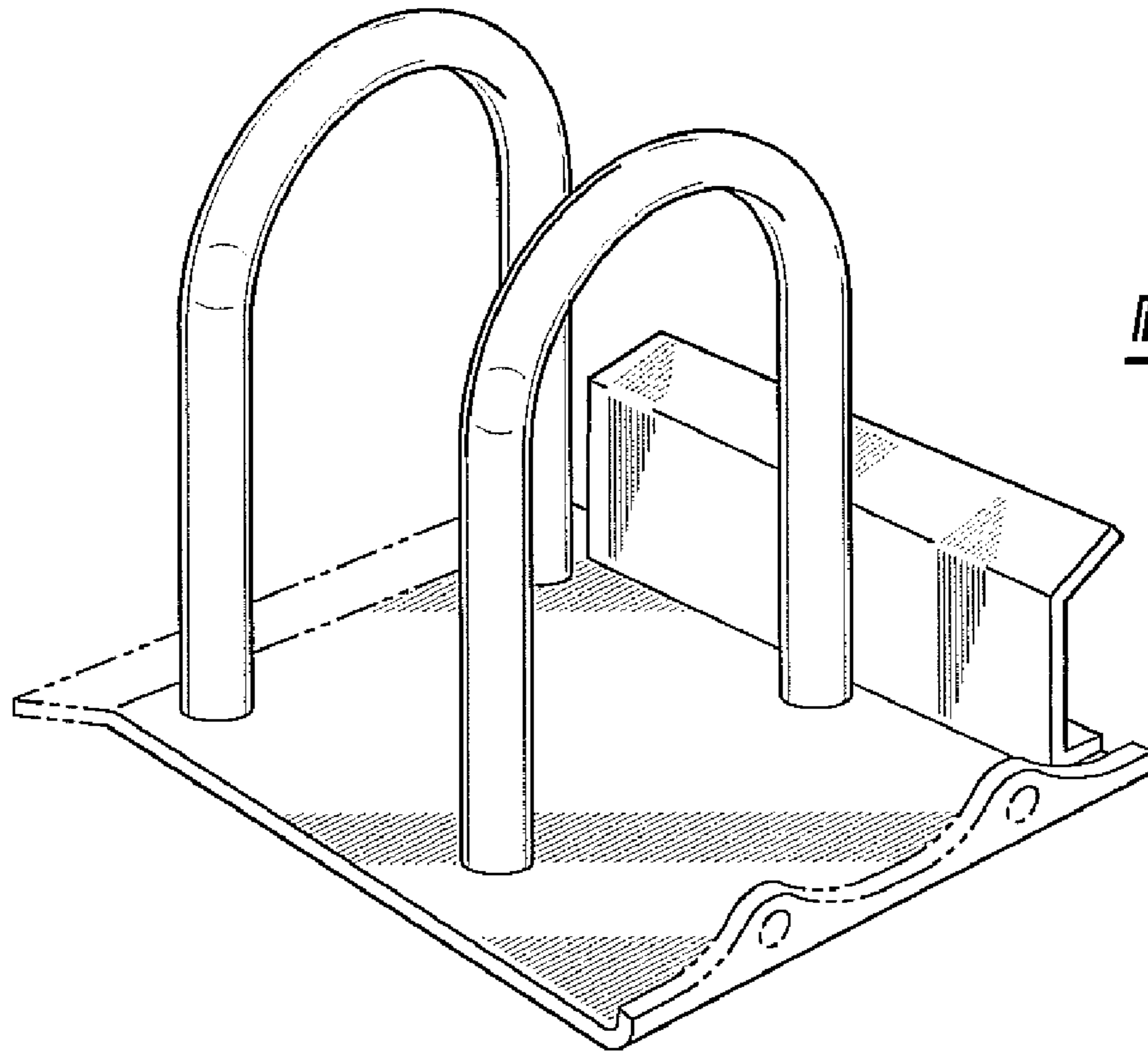

Fig-1

Fig-2

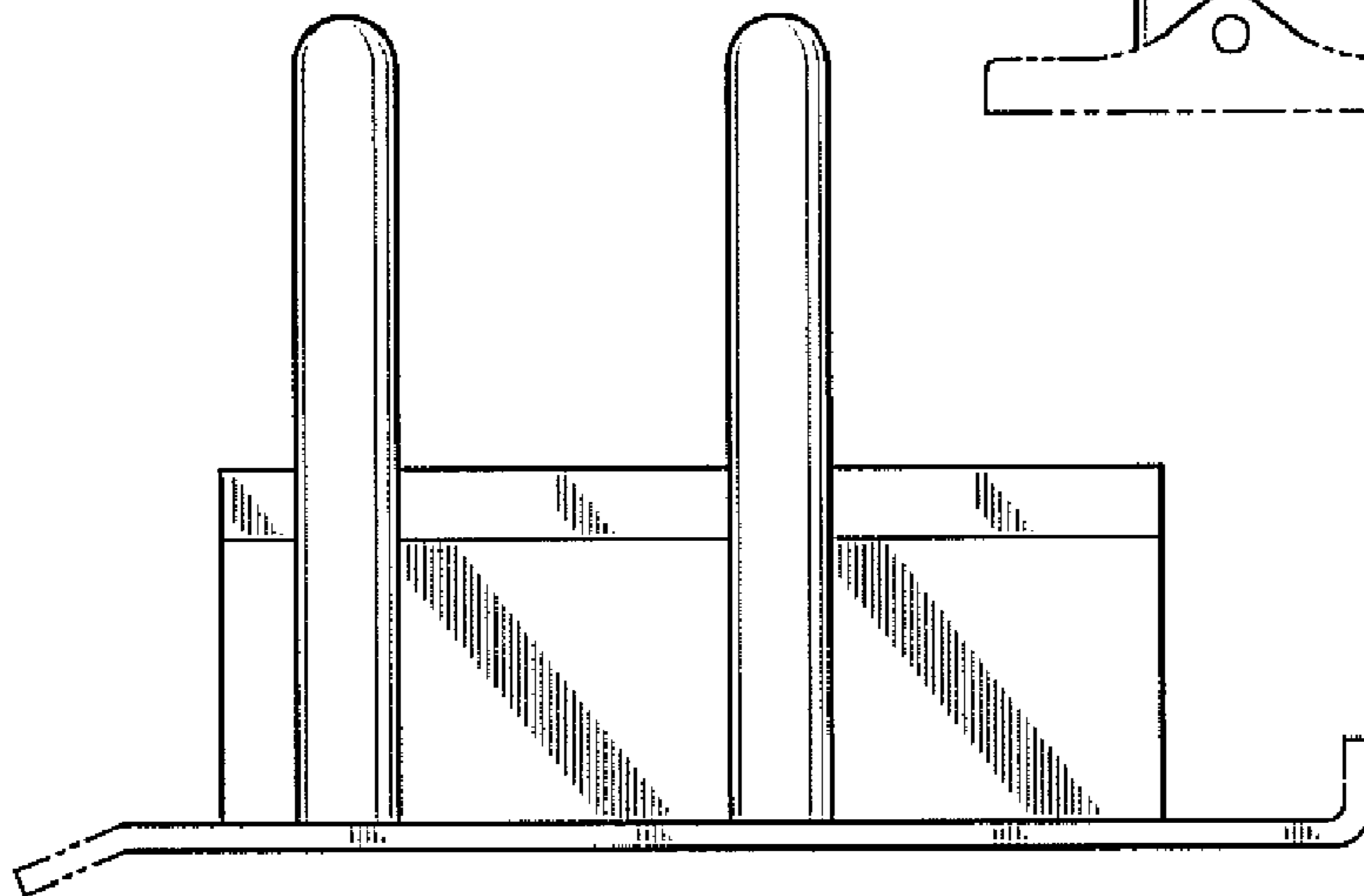
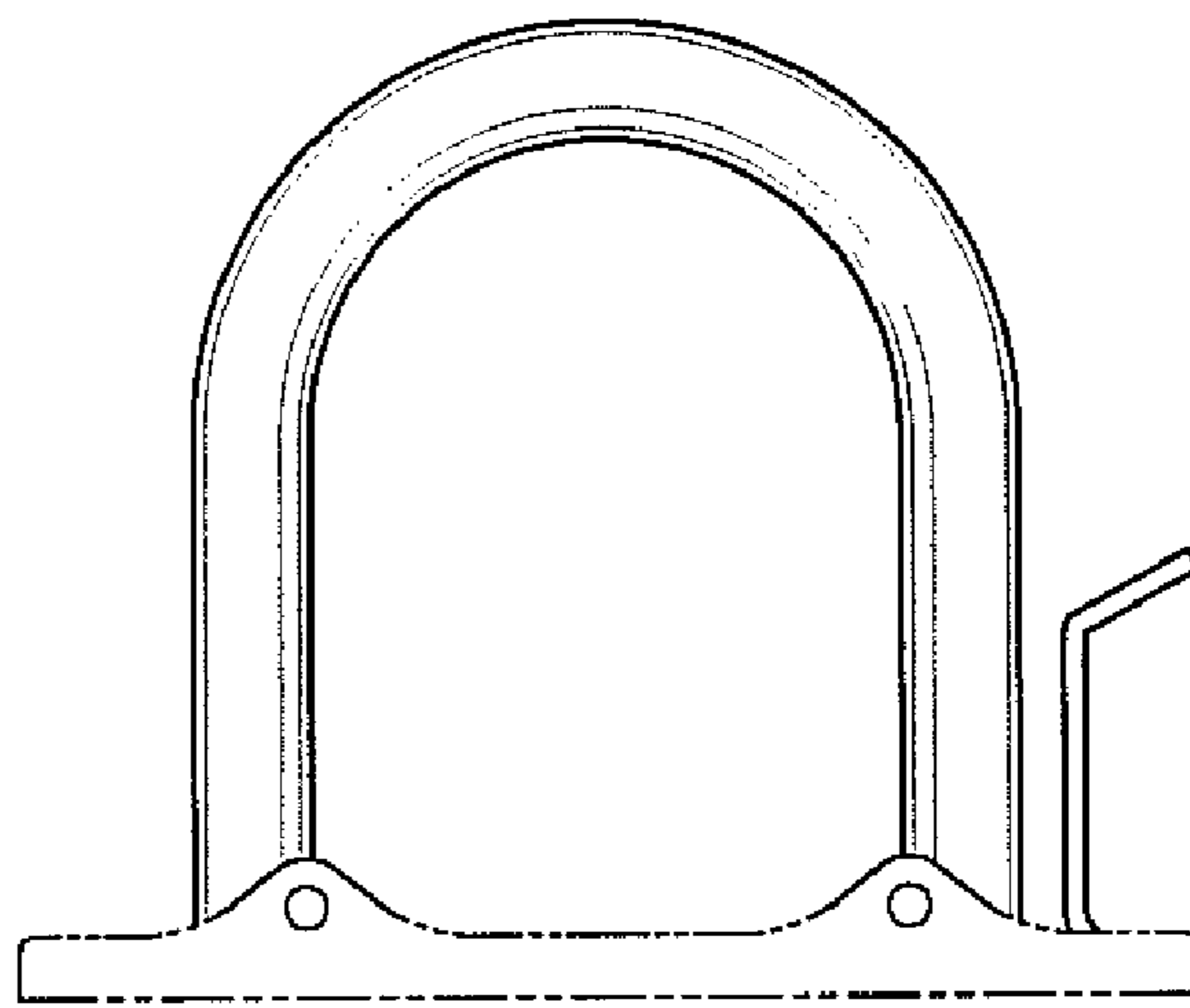

Fig-3

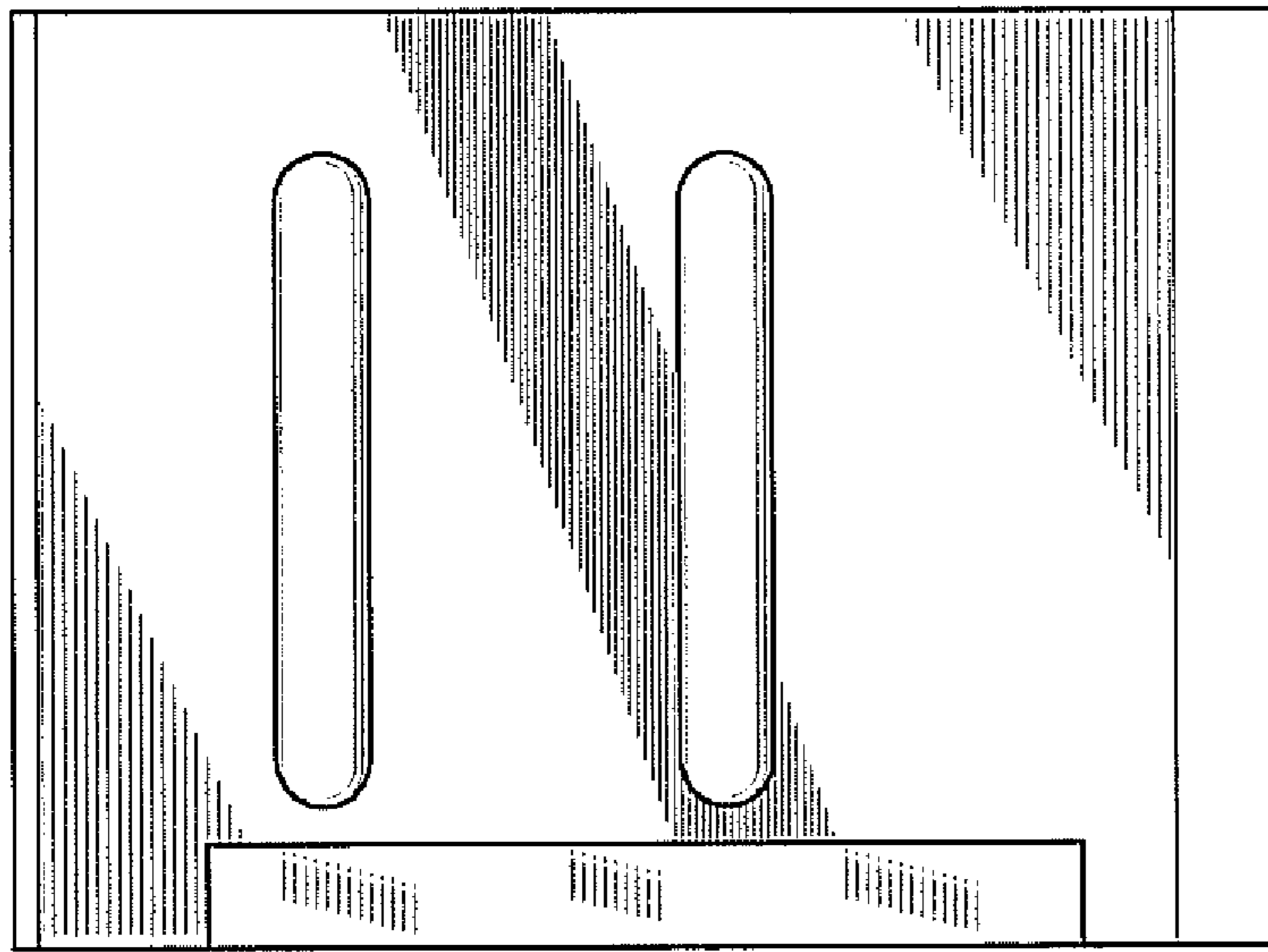

Fig-4

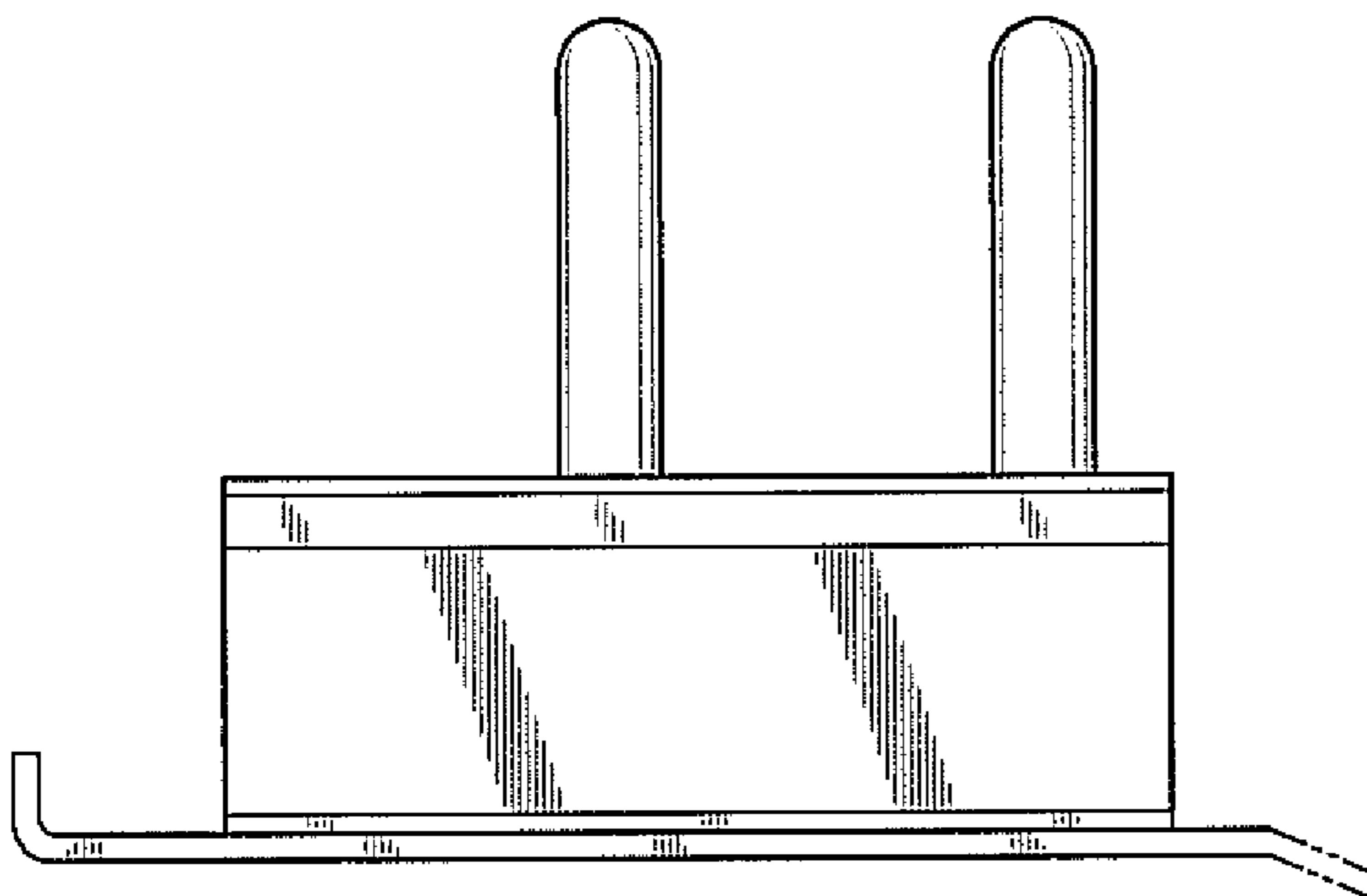

Fig-5

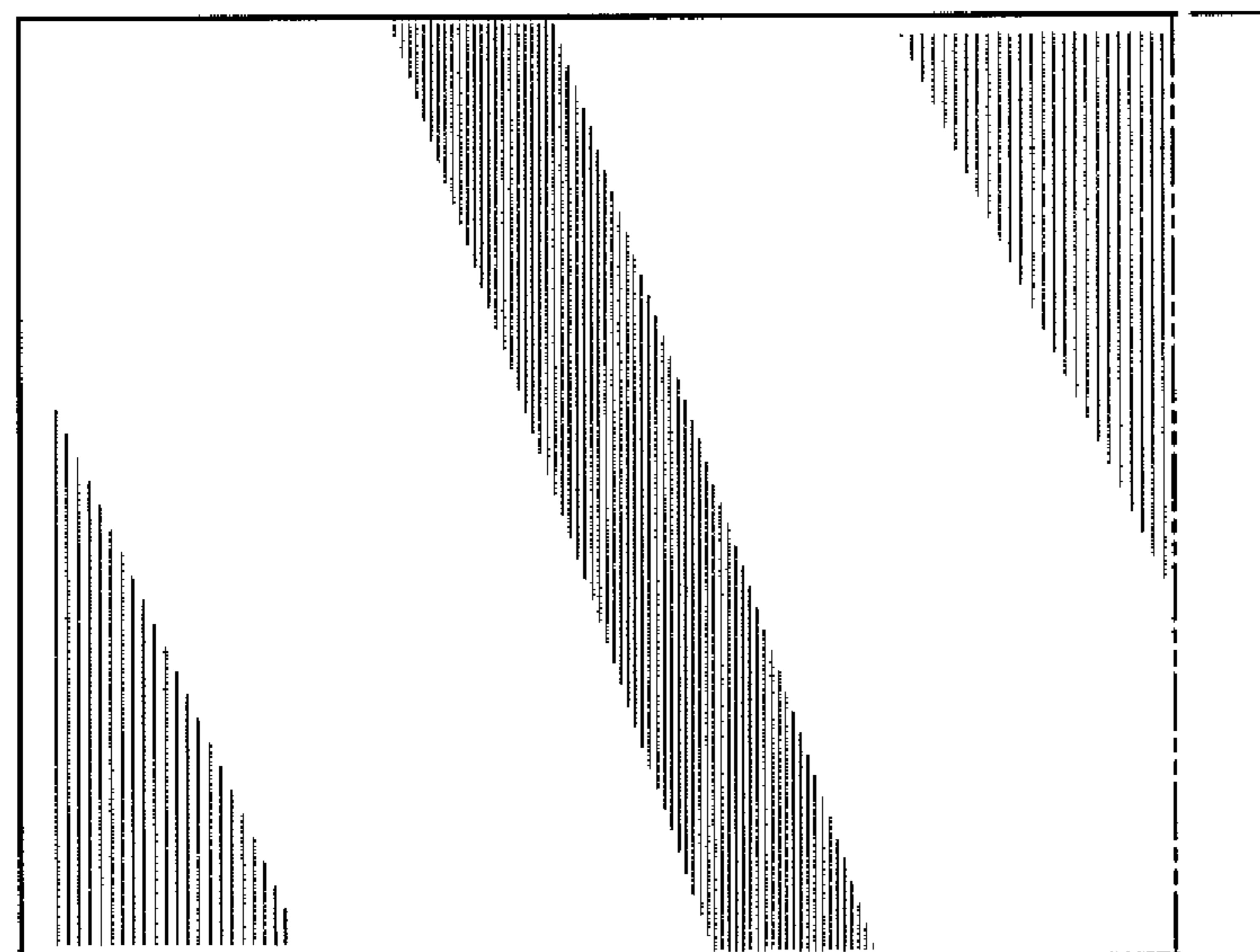

Fig-6

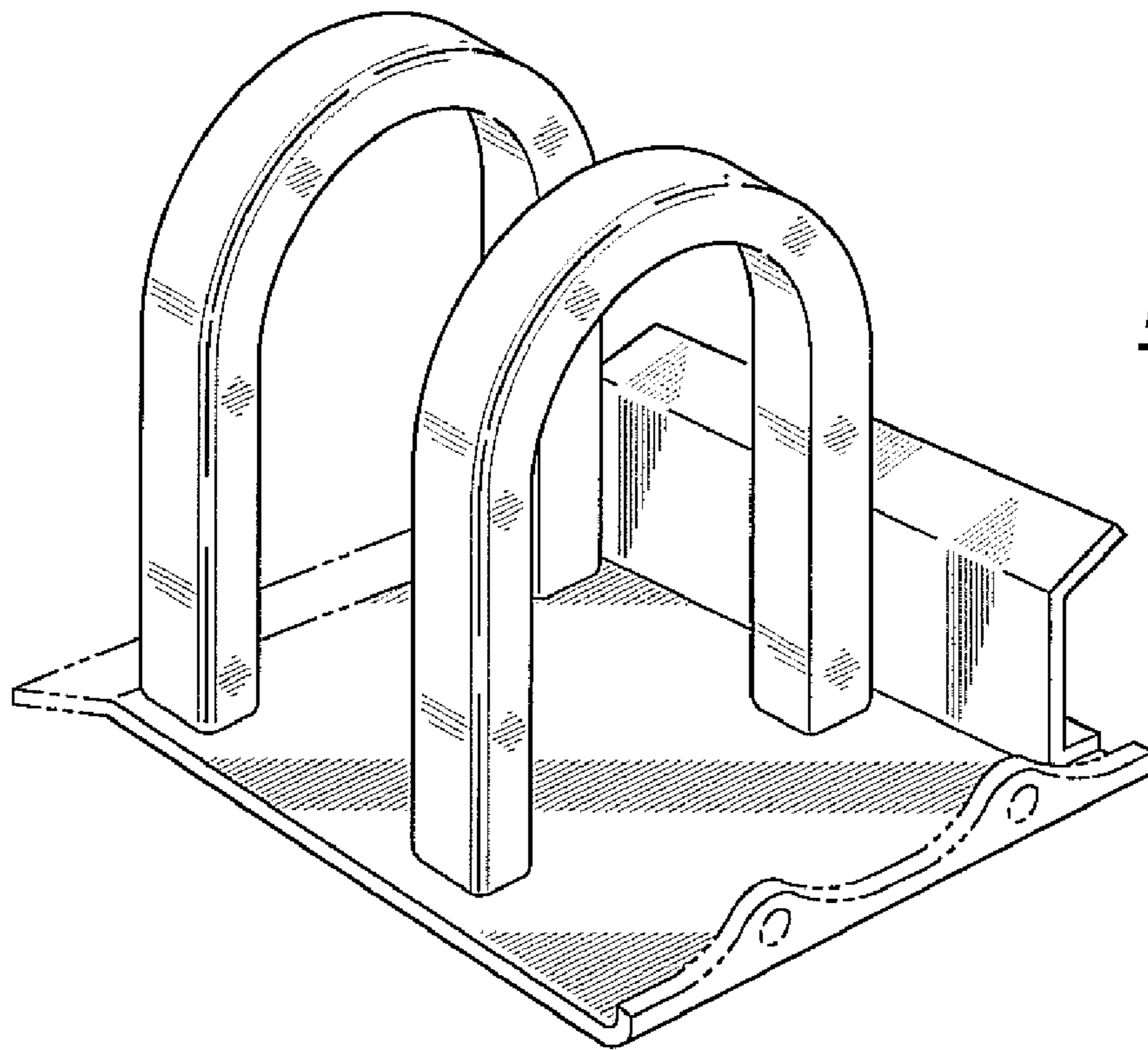

Fig-7

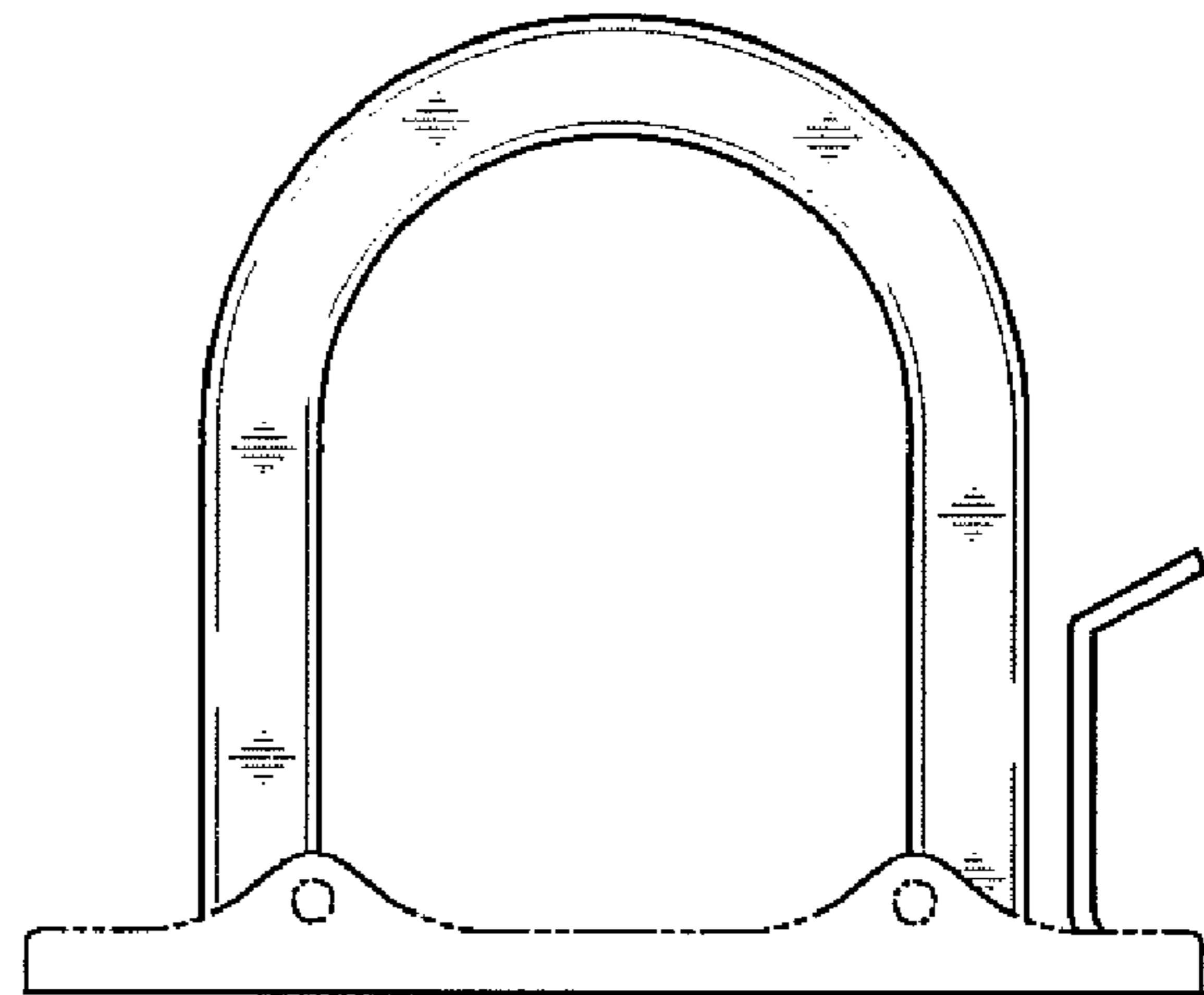

Fig-8

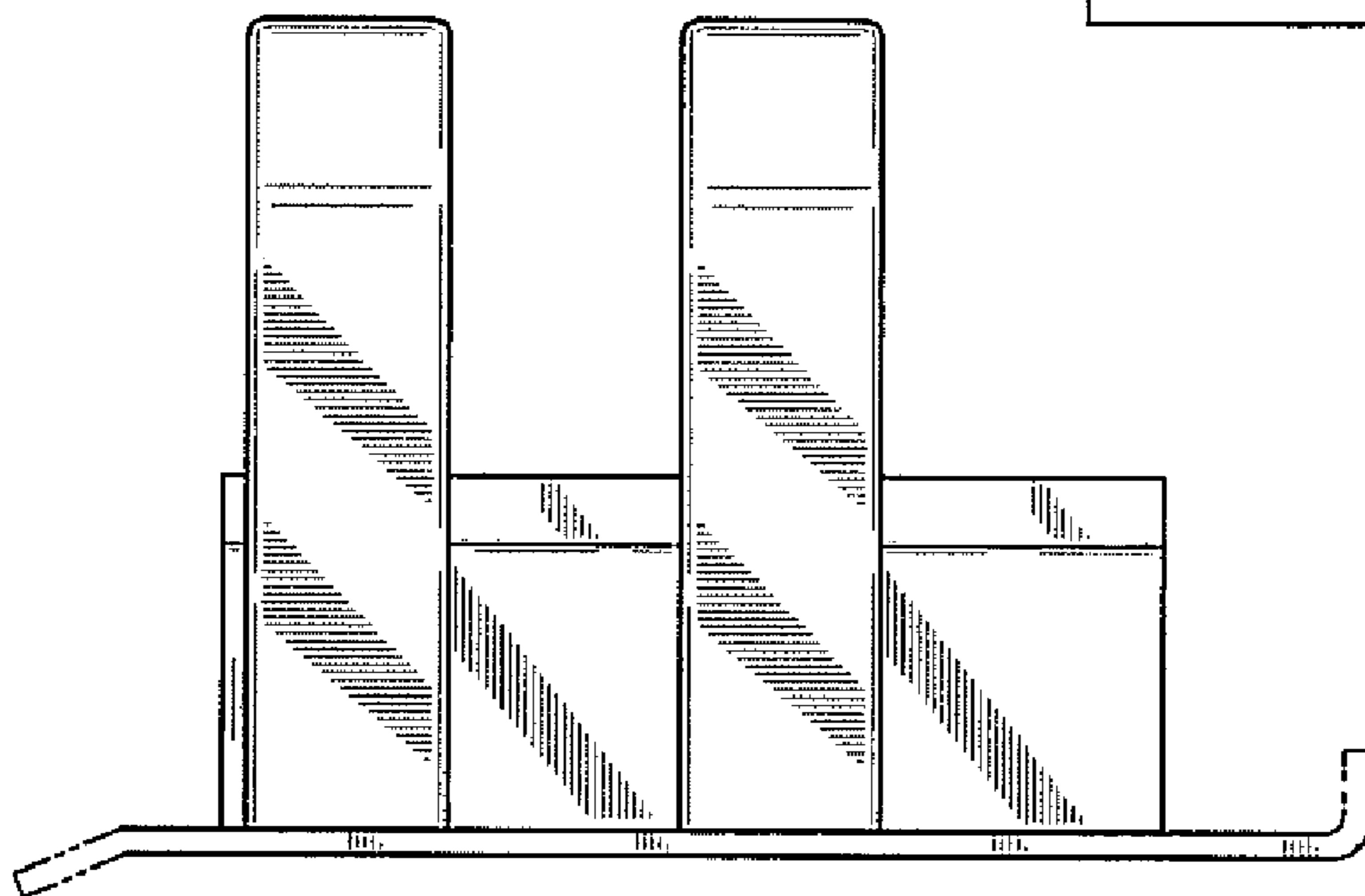

Fig-9

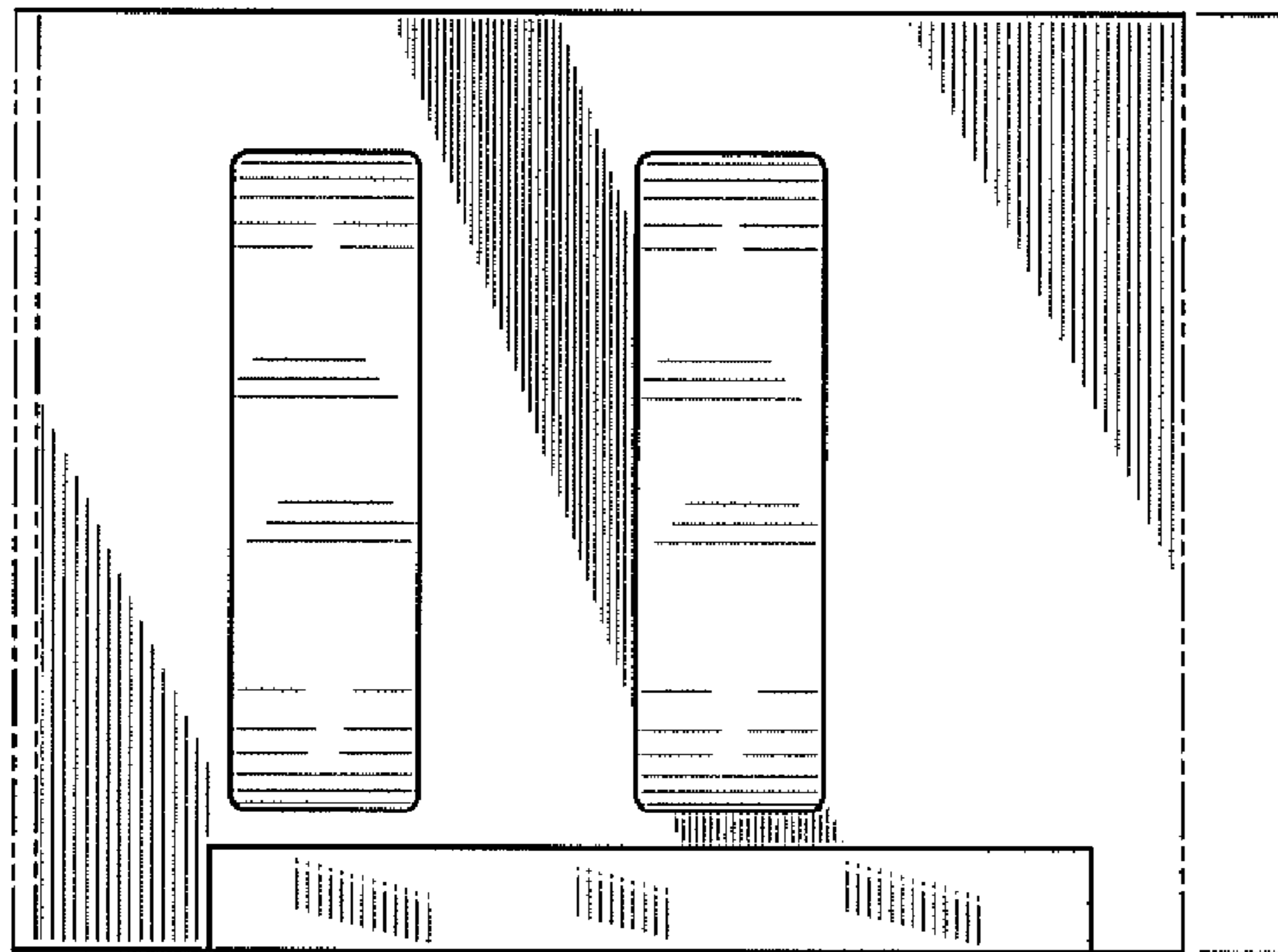

Fig-10

Fig-11

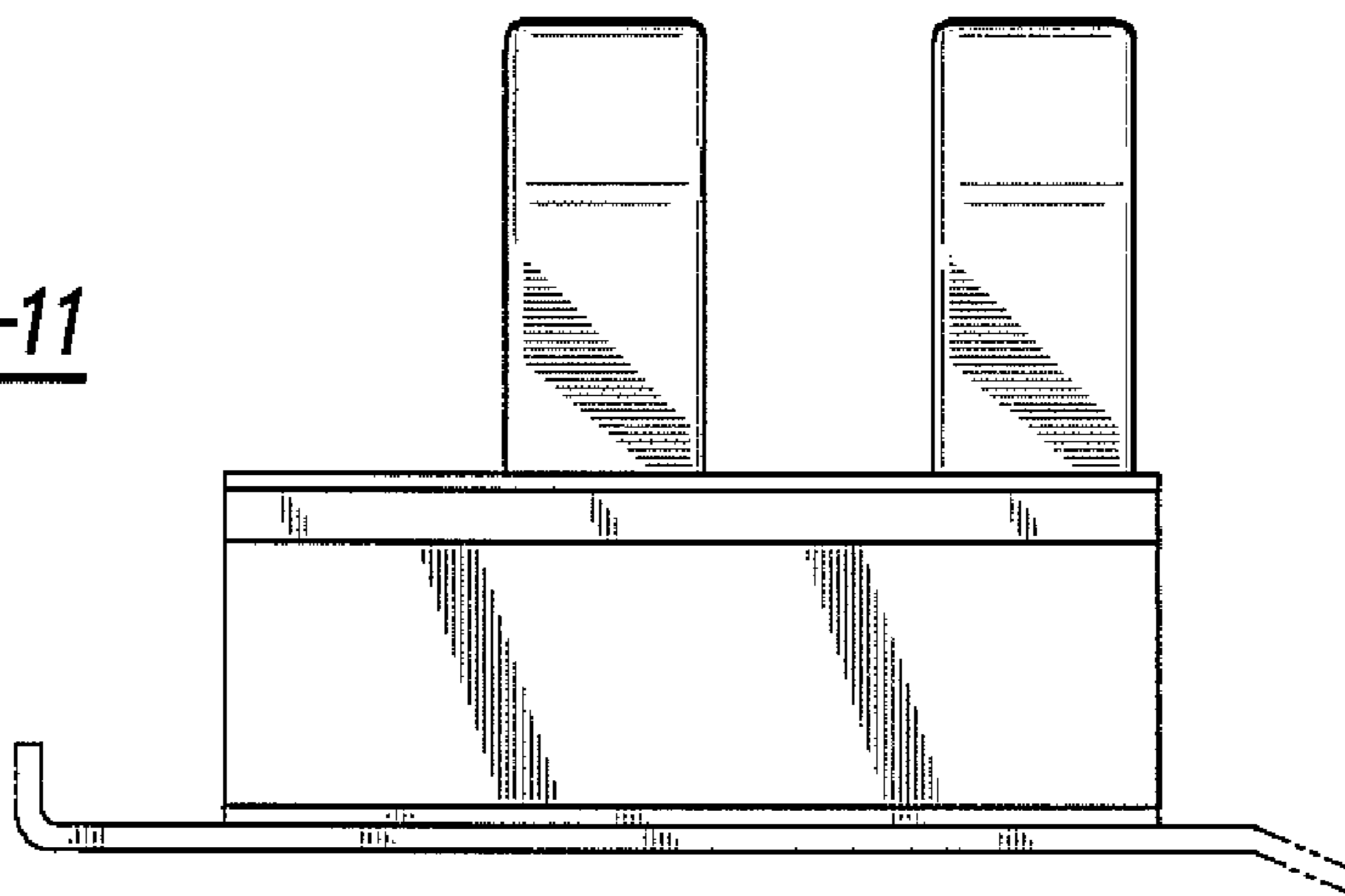

Fig-12

