



US00D603492S

(12) **United States Design Patent**  
**Lopez et al.**

(10) **Patent No.:** **US D603,492 S**  
(45) **Date of Patent:** **\*\* Nov. 3, 2009**

(54) **WATER HEATER**

(75) Inventors: **Moises Alejandro Avina Lopez**, Cd. Nezahualcoyotl (MX); **Alejandro Sanchez Gonzalez**, Cd. Nezahualcoyotl (MX)

(73) Assignee: **Calentadores de America S. de R.L. de C.V.**, Mexico City, C.P. (MX)

(\*\*) Term: **14 Years**

(21) Appl. No.: **29/305,264**

(22) Filed: **Mar. 17, 2008**

(30) **Foreign Application Priority Data**

Sep. 18, 2007 (MX) ..... MX/F/2007/001969

(51) **LOC (9) Cl.** ..... **23-03**

(52) **U.S. Cl.** ..... **D23/318**

(58) **Field of Classification Search** ..... D23/318,  
D23/322, 319, 320, 321, 334; 126/361, 35 R;  
122/13.2, 14, 15, 19.2; 392/449, 451, 454  
See application file for complete search history.

(56) **References Cited**

**U.S. PATENT DOCUMENTS**

- D108,706 S \* 3/1938 Sands ..... D23/318
- D127,517 S 5/1941 Fowler
- D131,955 S 4/1942 Stangle
- D145,078 S 6/1946 Green
- D145,106 S 6/1946 Schladermundt
- 2,617,391 A 11/1952 Raymond
- 3,767,894 A \* 10/1973 Berger ..... 219/472
- D262,992 S 2/1982 Owen
- D300,352 S \* 3/1989 Ronvik ..... D23/318

- D310,260 S \* 8/1990 Gauer et al. .... D23/321
- D347,274 S 5/1994 Prevost
- D351,900 S 10/1994 Prevot
- D361,073 S 8/1995 Walters et al.
- D388,868 S \* 1/1998 Vago et al. .... D23/318
- D400,971 S \* 11/1998 Vago et al. .... D23/318
- D485,893 S 1/2004 Du et al.
- D486,897 S 2/2004 Rolph et al.
- D532,497 S 11/2006 Engel et al.
- D550,825 S 9/2007 McNeely et al.
- D553,728 S 10/2007 McNeely et al.
- 2001/0031137 A1 10/2001 Jones-Lawlor et al.

\* cited by examiner

*Primary Examiner*—T. Chase Nelson

*Assistant Examiner*—Ania K Dworzecka

(74) *Attorney, Agent, or Firm*—Dority & Manning, P.A.

(57) **CLAIM**

The ornamental design for a water heater, as shown and described.

**DESCRIPTION**

FIG. 1 is a perspective view of a water heater showing our new design;

FIG. 2 is a front elevational view thereof;

FIG. 3 is a rear elevational view thereof;

FIG. 4 is a left side view thereof;

FIG. 5 is a right side view thereof;

FIG. 6 is a bottom plan view thereof; and,

FIG. 7 is a top plan view.

The portions of the water heater shown in dashed lines do not form a part of the claimed design.

**1 Claim, 6 Drawing Sheets**

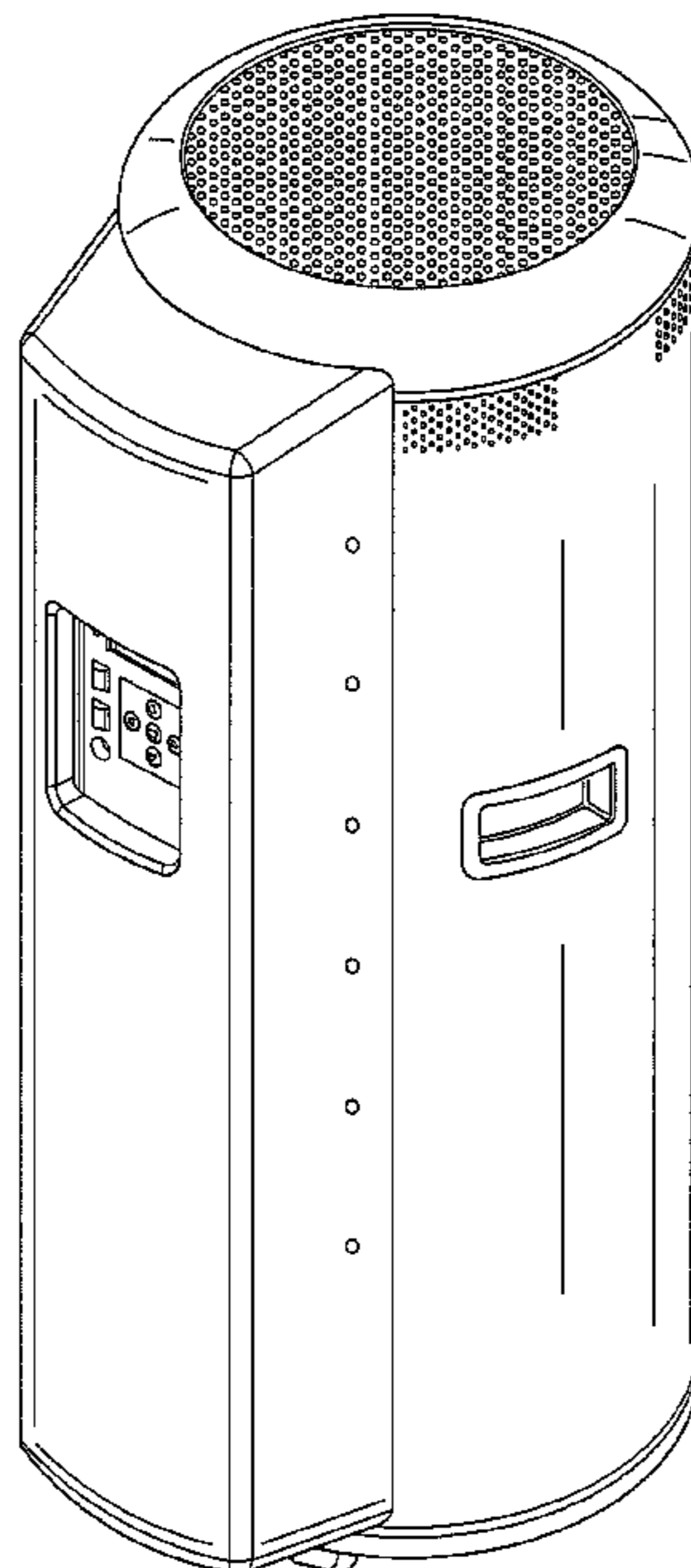

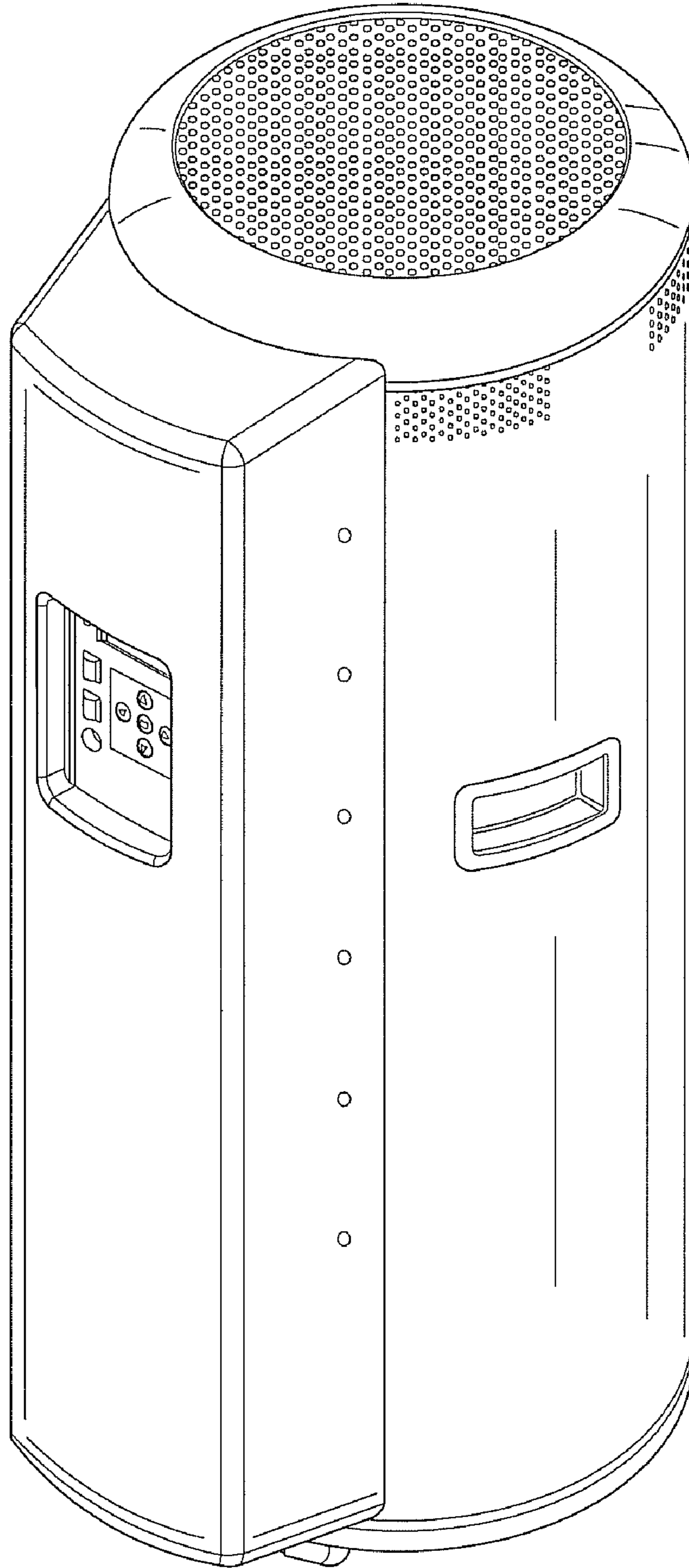

FIG. 1

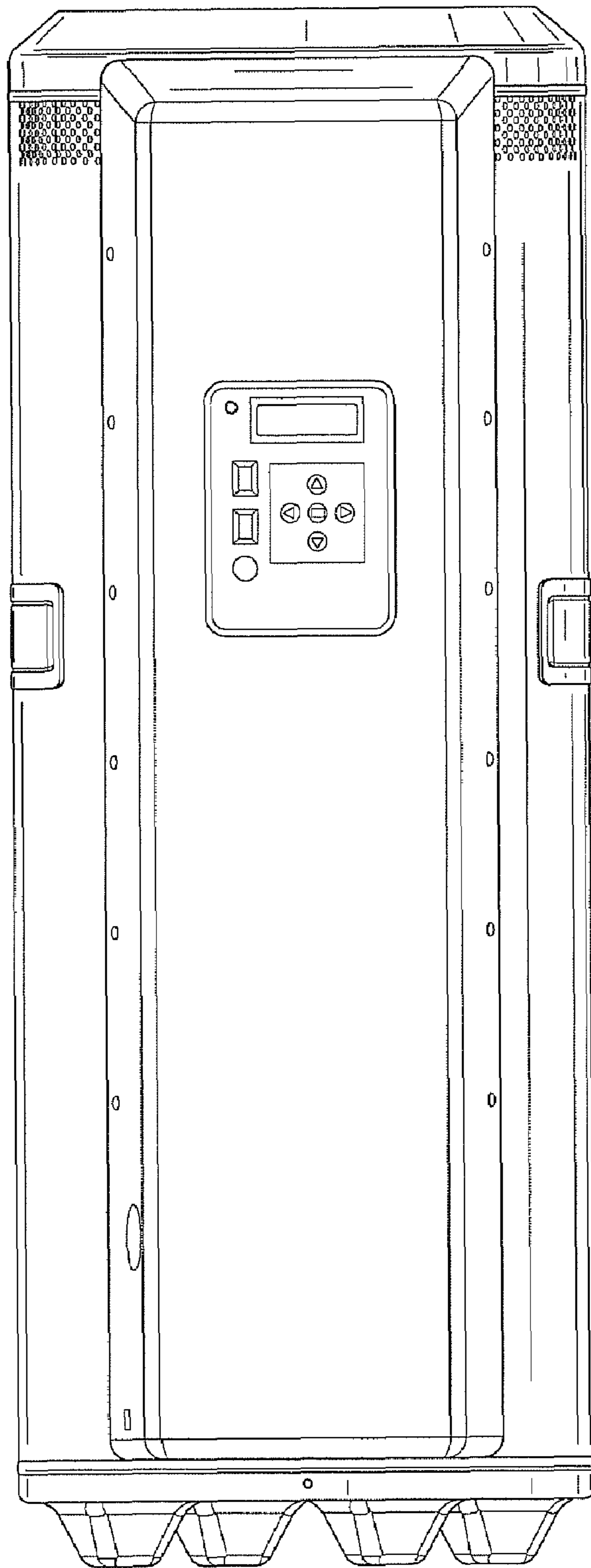

FIG. 2

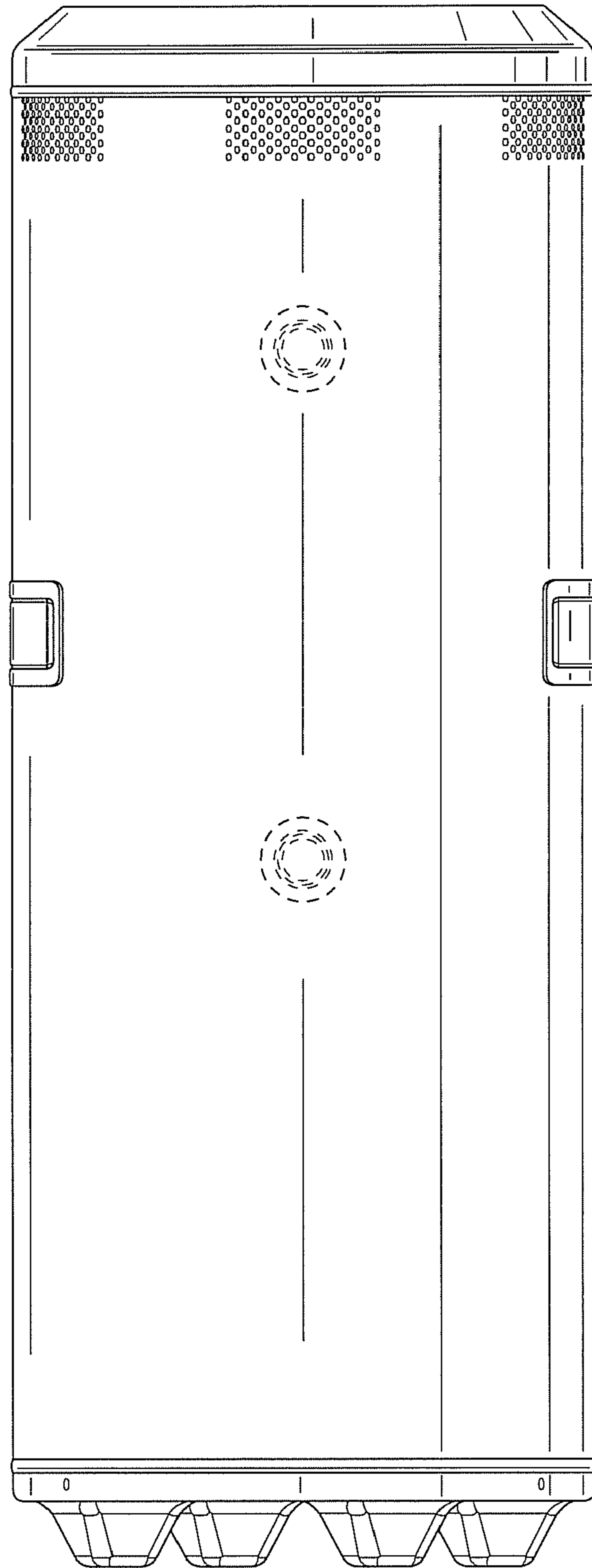

FIG. 3

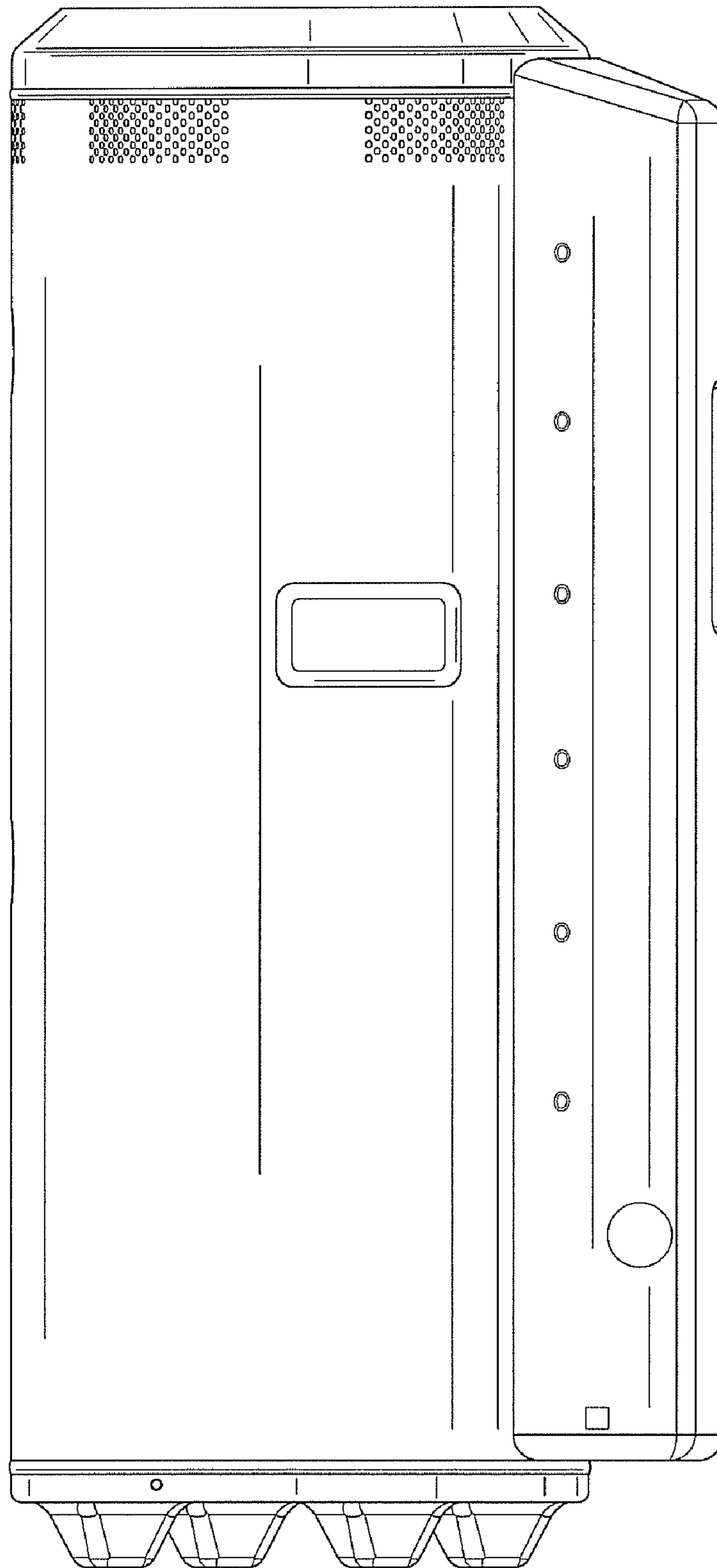

FIG. 4

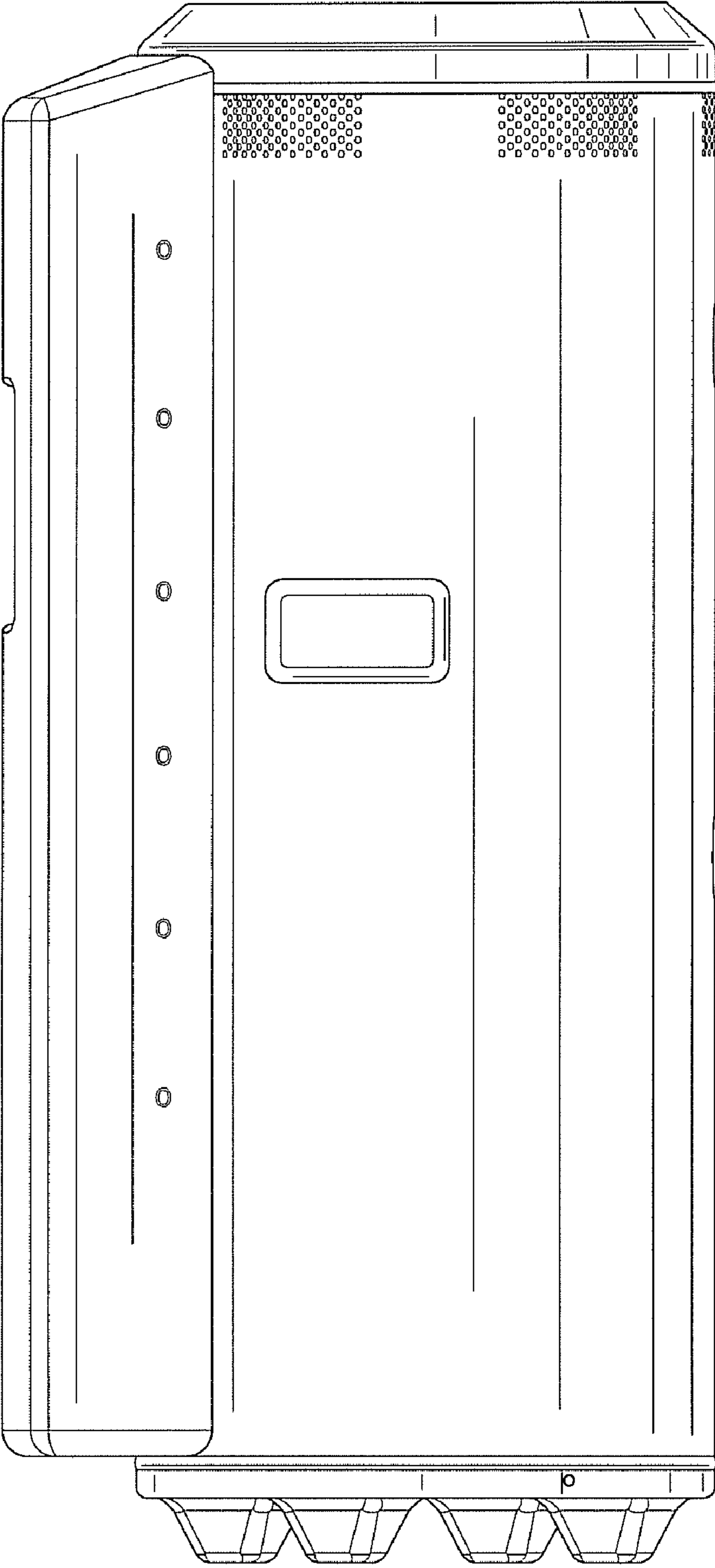
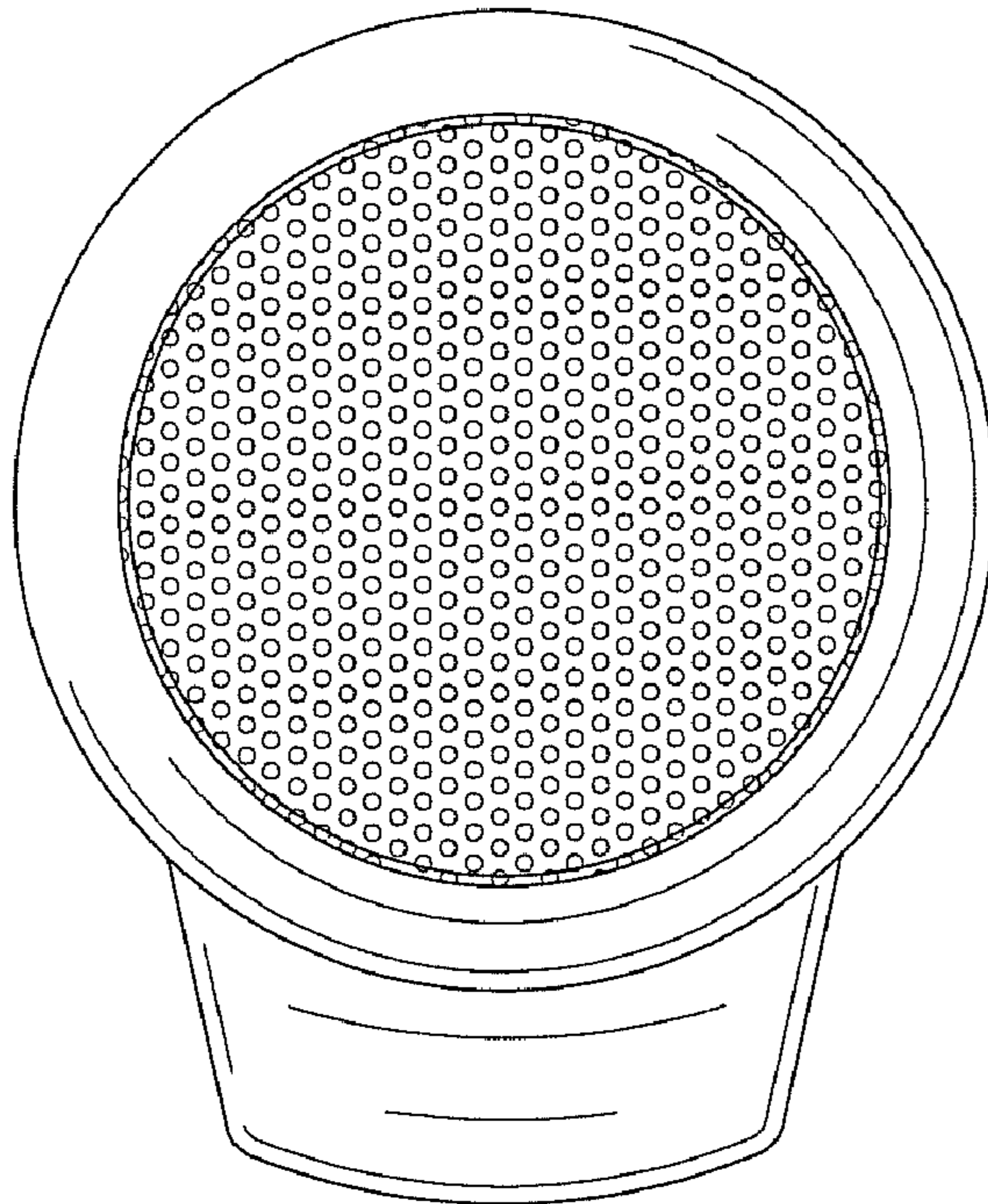
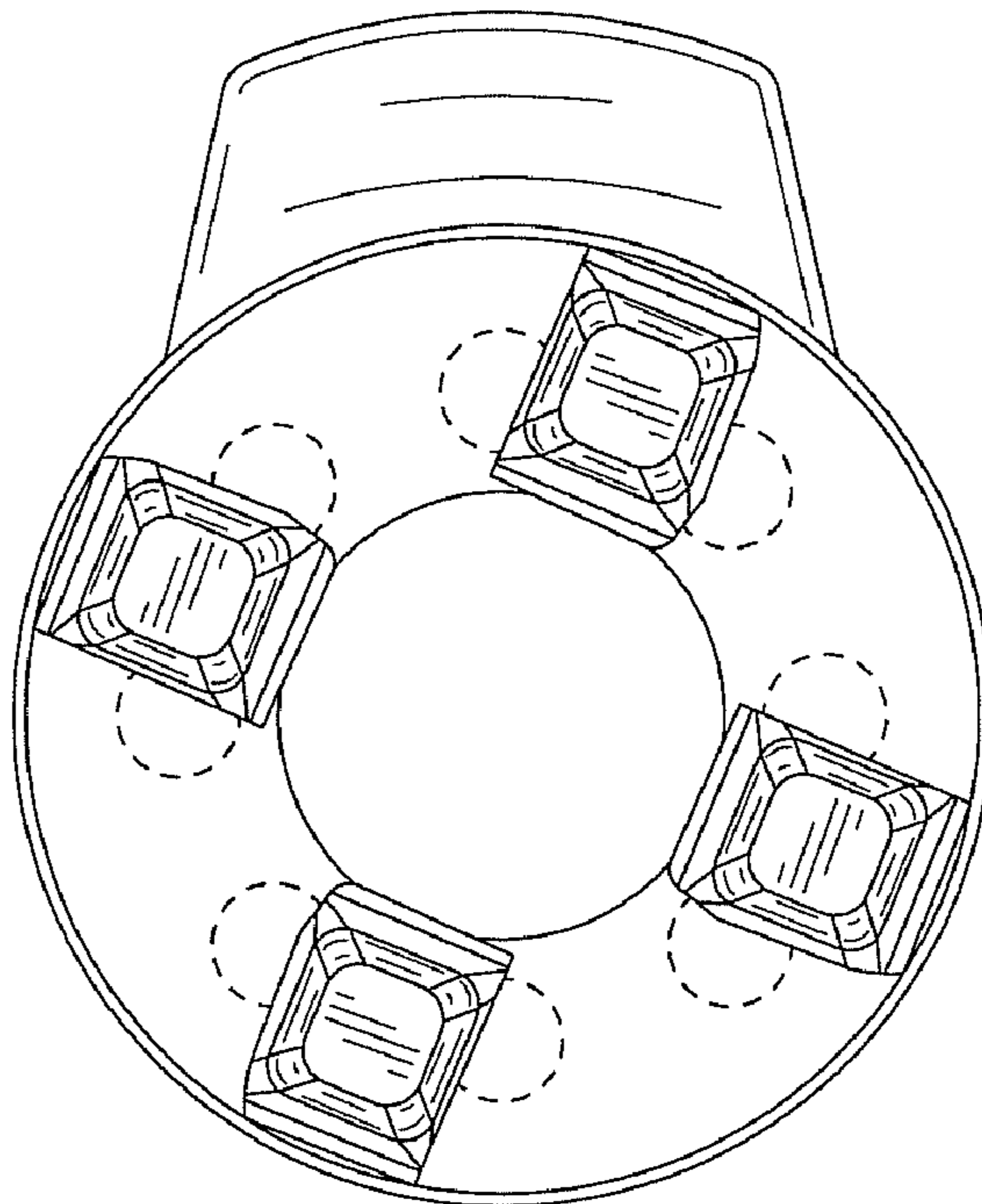

FIG. 5



**FIG. 6**



**FIG. 7**