



US00D603314S

(12) **United States Design Patent**
Schmitz et al.

(10) **Patent No.:** **US D603,314 S**

(45) **Date of Patent:** **** Nov. 3, 2009**

(54) **INNER PORTION OF A BRAKE ROTOR**

(75) Inventors: **Johann Schmitz**, Wurmelingen (DE);
Ingo Hoffmann, Tuttlingen (DE)

(73) Assignee: **Schwabische Huttenwerke Automotive GmbH & Co. KG** (DE)

(**) Term: **14 Years**

(21) Appl. No.: **29/319,669**

(22) Filed: **Jun. 12, 2008**

(30) **Foreign Application Priority Data**

Dec. 12, 2007 (DE) 407 06 127

(51) **LOC (9) Cl.** **12-16**

(52) **U.S. Cl.** **D12/180**

(58) **Field of Classification Search** D12/179-180;
188/218 XL, 264 R, 26, 73, 1, 24.22, 73.31-73.43
See application file for complete search history.

(56) **References Cited**

U.S. PATENT DOCUMENTS

D458,882 S *	6/2002	Oberti	D12/180
D465,179 S *	11/2002	Ballinger	D12/180
D482,643 S *	11/2003	Gavin	D12/180
D484,836 S *	1/2004	Gavin	D12/180
7,159,698 B2 *	1/2007	Banks et al.	188/218 XL
D565,487 S	4/2008	Zhang		

2006/0086579 A1 *	4/2006	Gerber	188/218 XL
2006/0124410 A1 *	6/2006	Drage	188/218 XL
2007/0199778 A1 *	8/2007	Lee	188/218 XL
2008/0135359 A1 *	6/2008	Basirico et al.	188/218 XL
2009/0000884 A1 *	1/2009	Layton et al.	188/218 XL
2009/0020379 A1 *	1/2009	Hanna et al.	188/218 XL

* cited by examiner

Primary Examiner—Antoine D Davis

(74) *Attorney, Agent, or Firm*—GrayRobinson, P.A.

(57) **CLAIM**

The ornamental design of an inner portion of a brake rotor, as shown and described.

DESCRIPTION

FIG. 1 is a front elevational view of a first embodiment thereof;

FIG. 2 is a partial perspective view of the embodiment of FIG. 1;

FIG. 3 is a front elevational view of a second embodiment thereof;

FIG. 4 is a partial perspective view of the embodiment of FIG. 3;

FIG. 5 is a front elevational view of a third embodiment thereof; and,

FIG. 6 is a perspective view of the embodiment of FIG. 5.

1 Claim, 3 Drawing Sheets

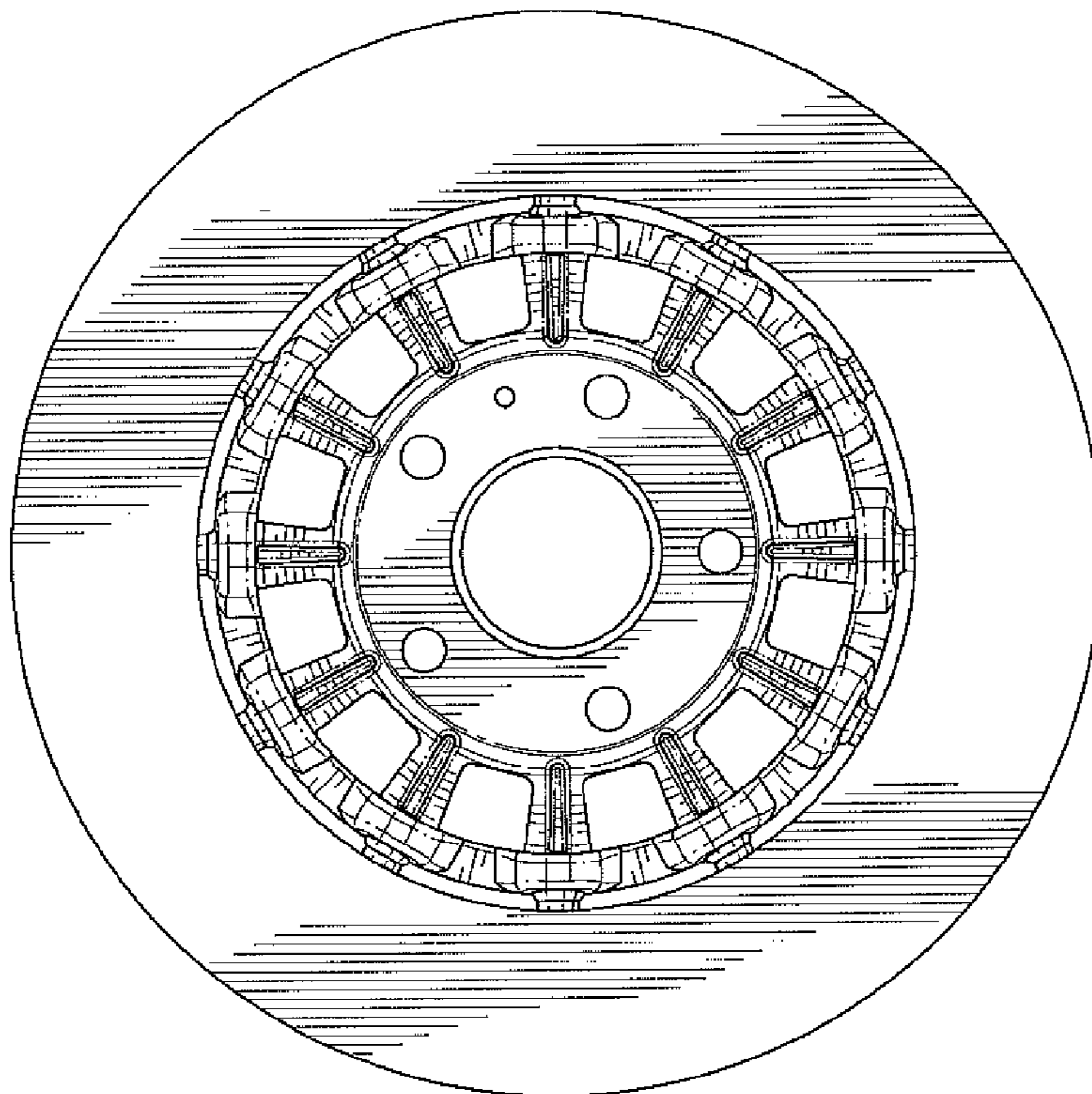

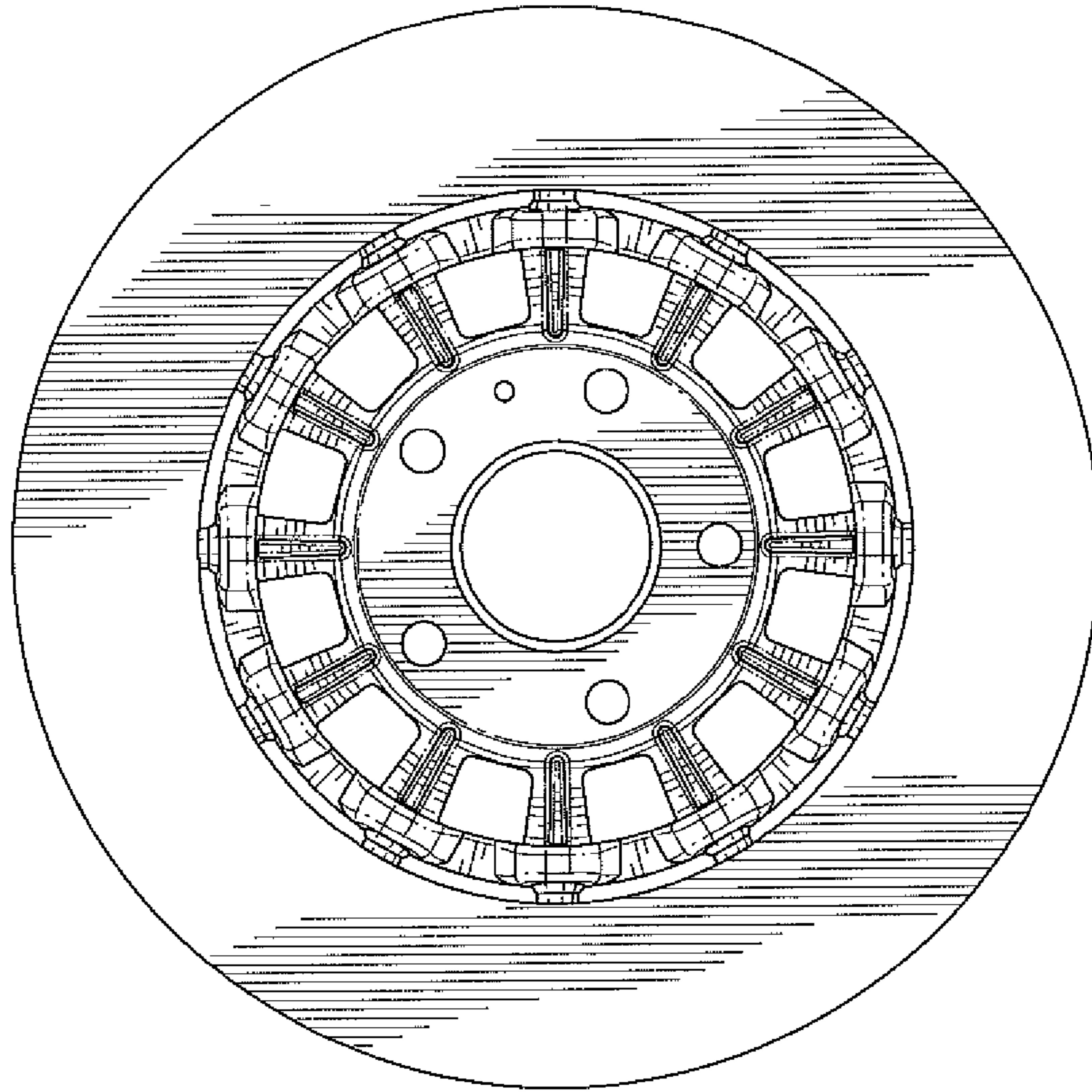

FIG. 1

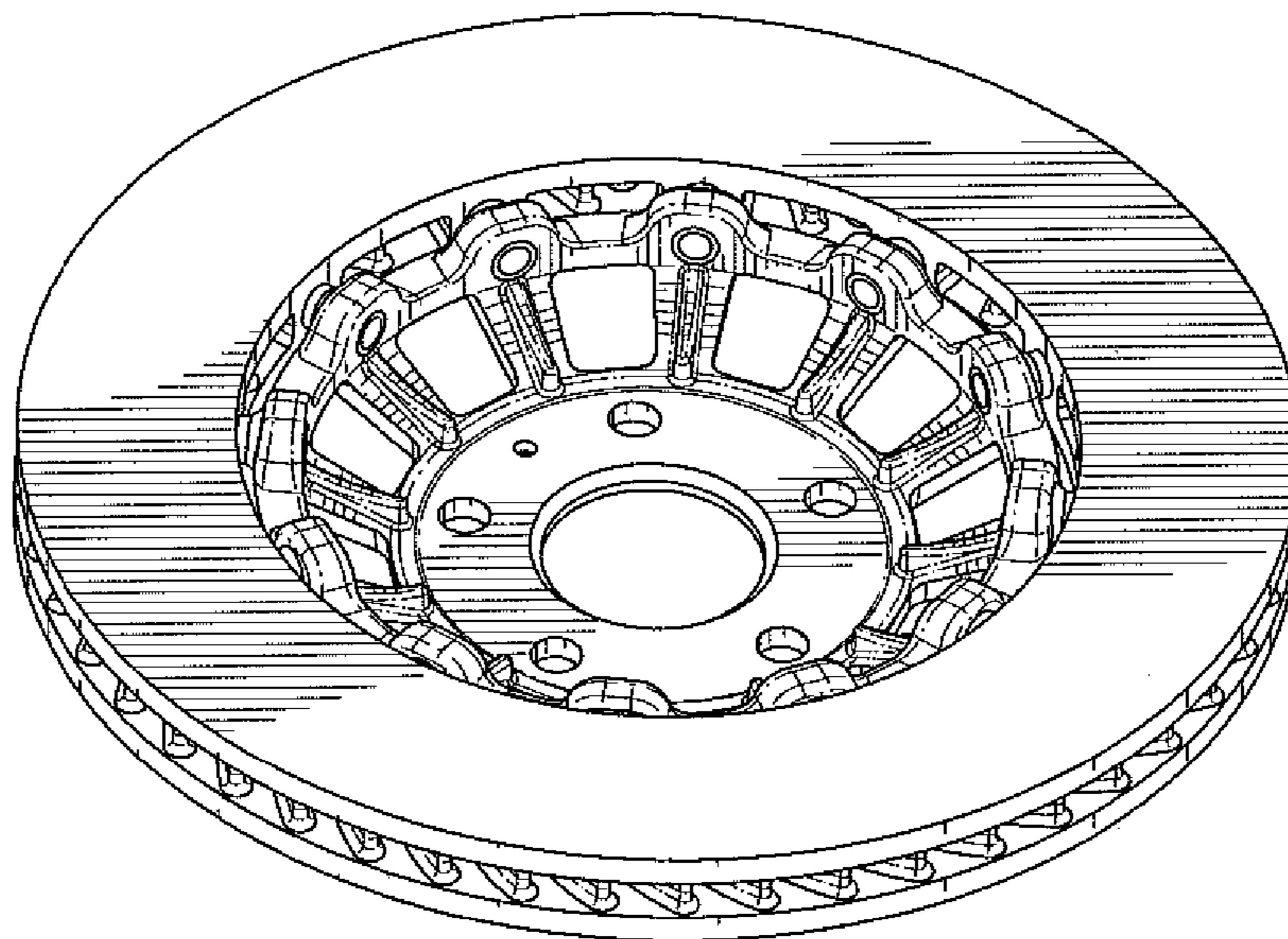

FIG. 2

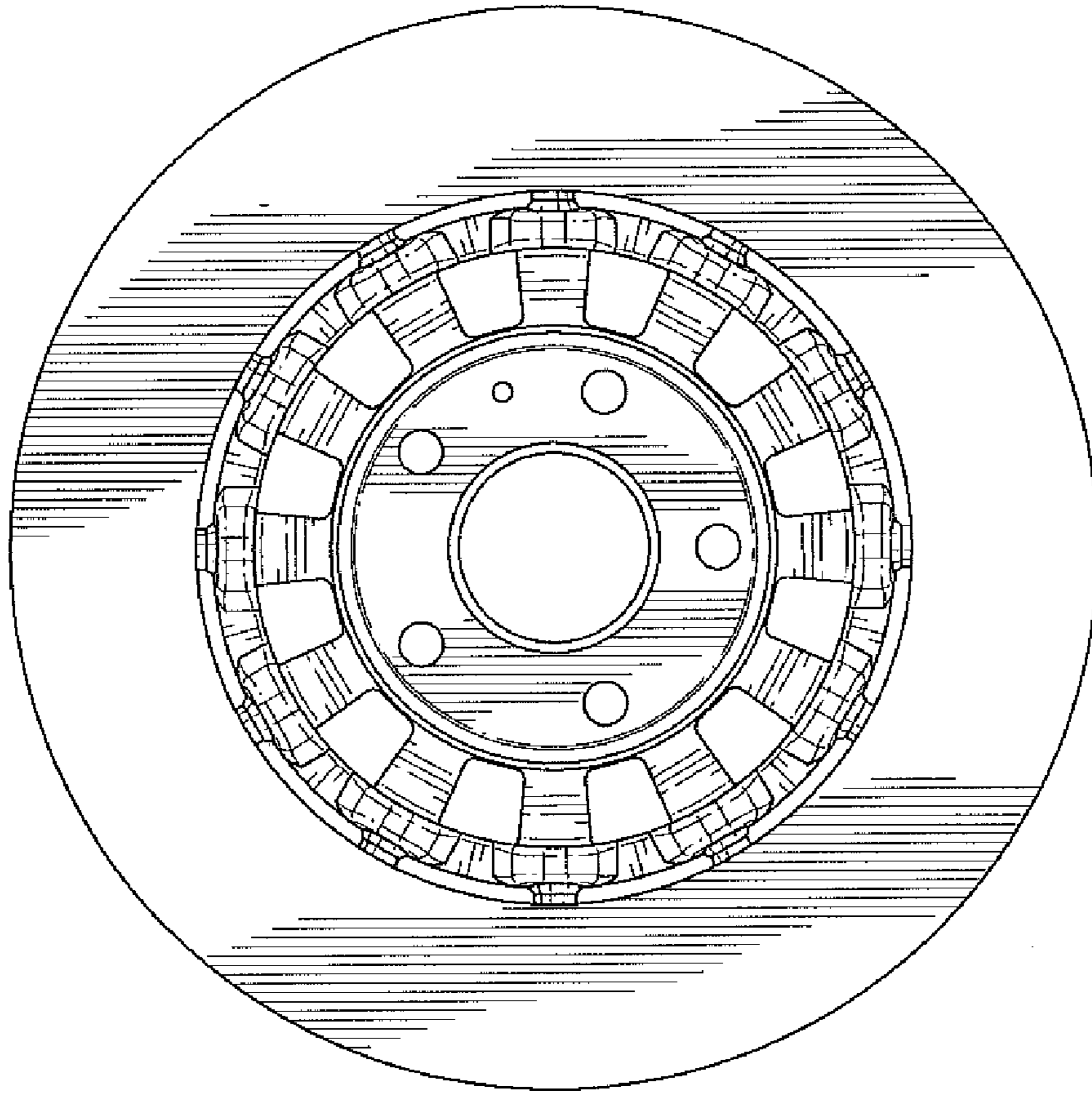

FIG. 3

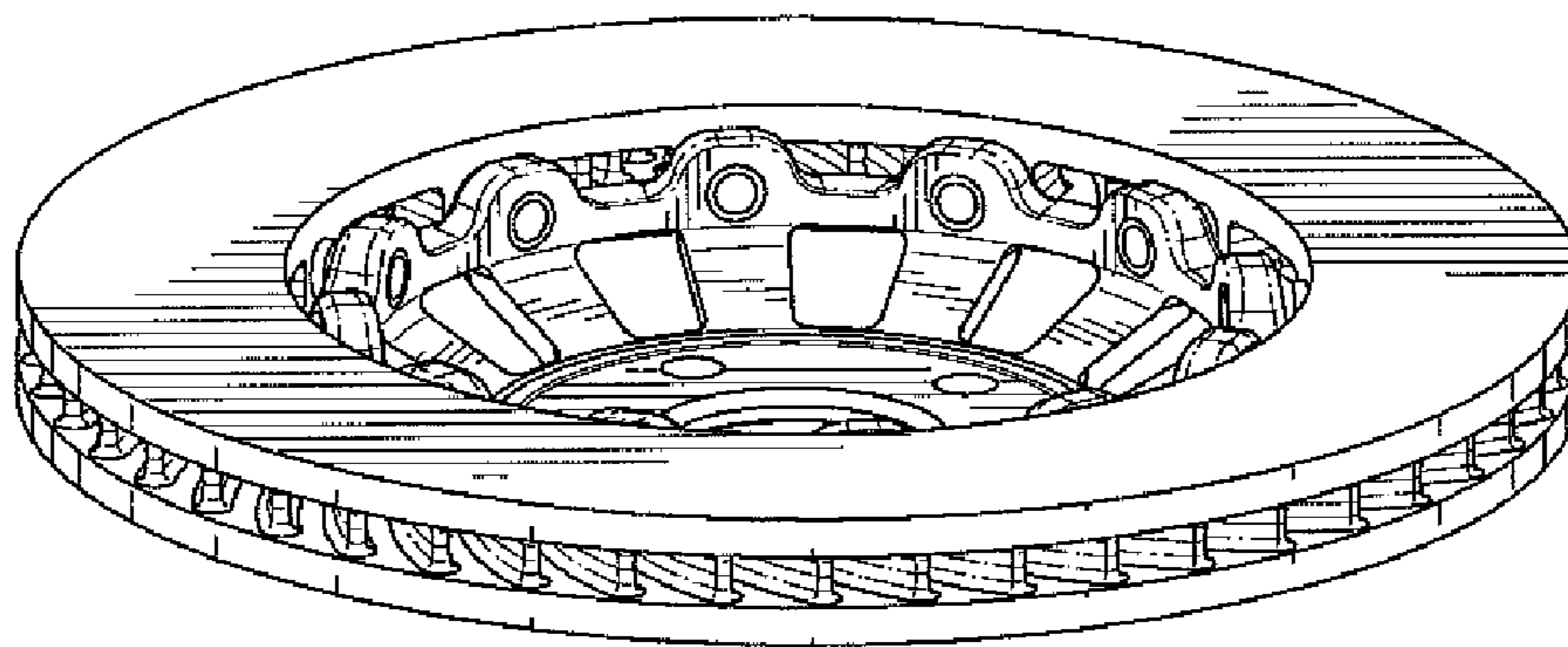

FIG. 4

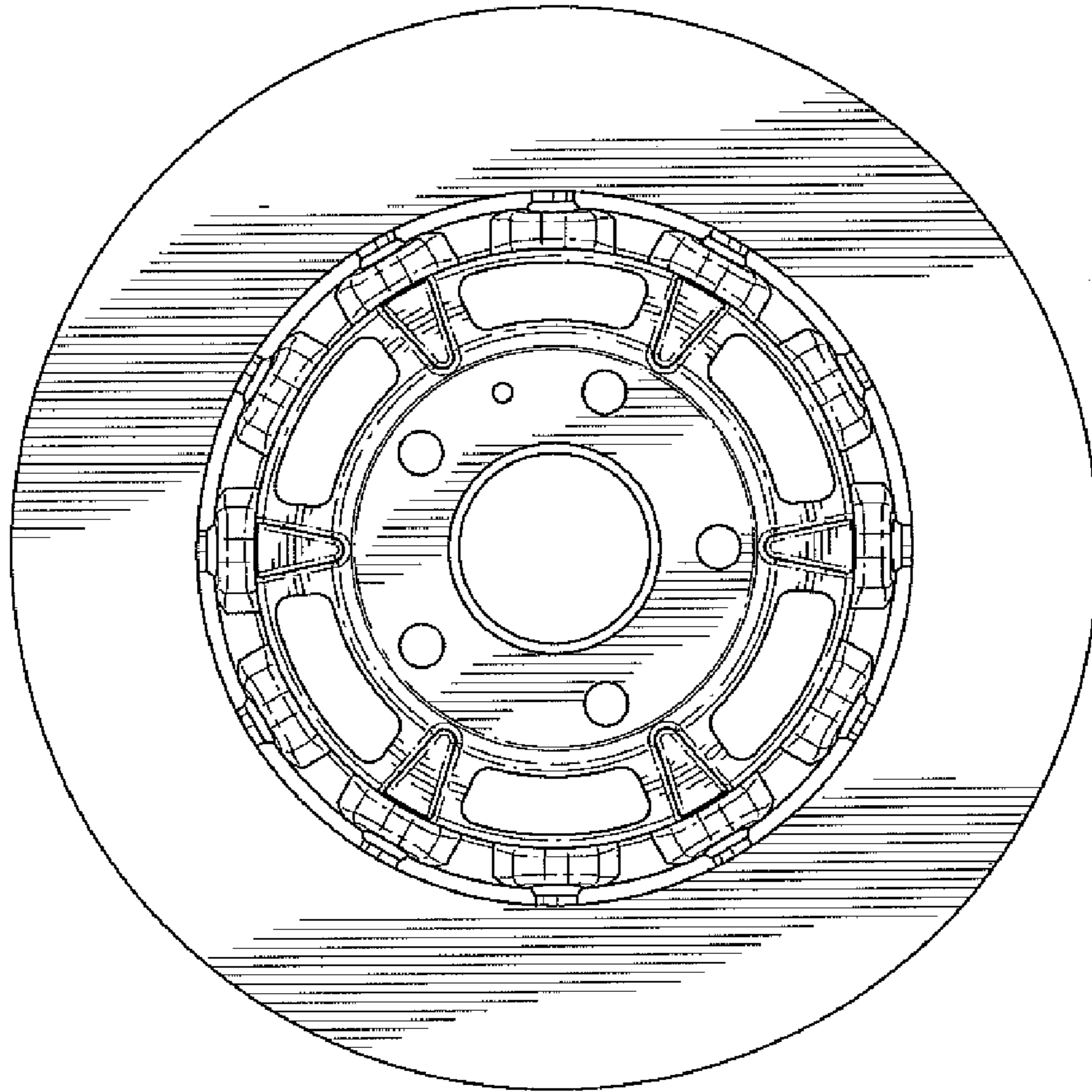

FIG. 5

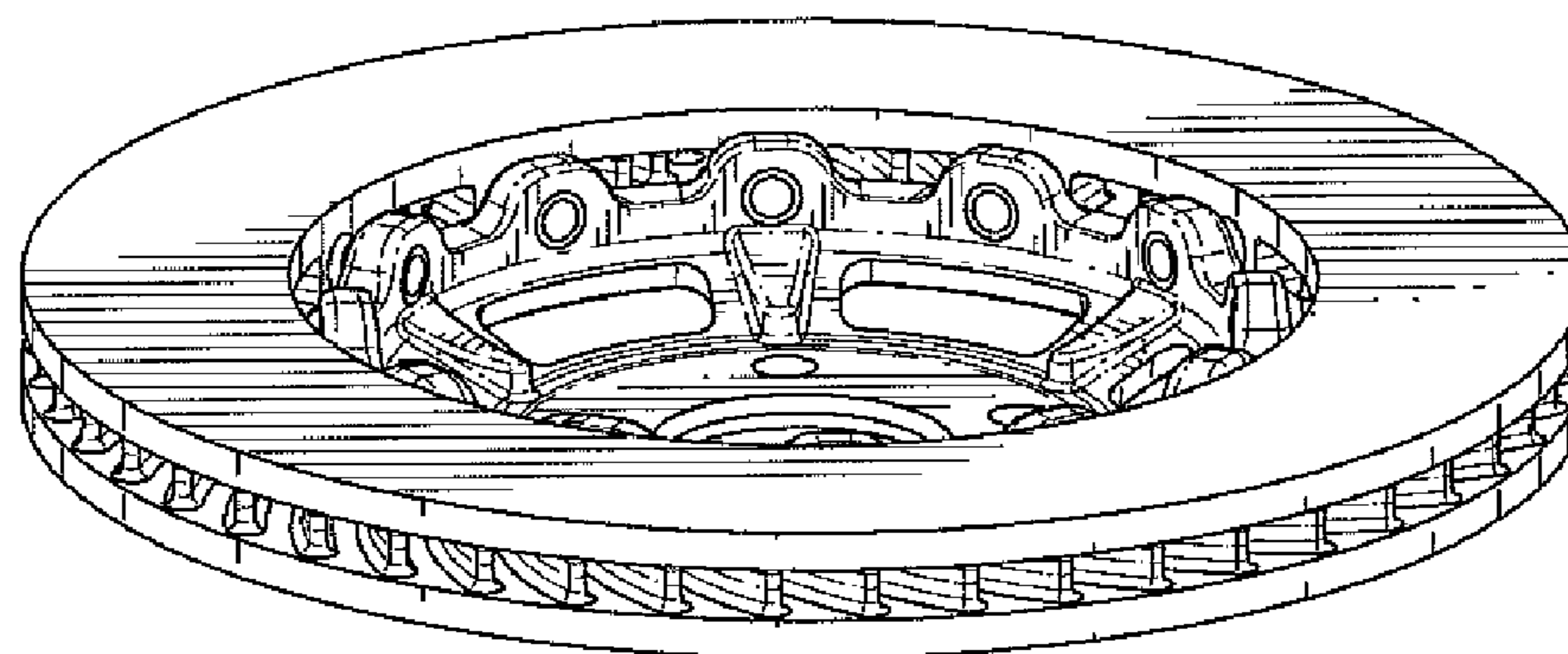

FIG. 6

UNITED STATES PATENT AND TRADEMARK OFFICE
CERTIFICATE OF CORRECTION

PATENT NO. : Des. 603,314 S
APPLICATION NO. : 29/319669
DATED : November 3, 2009
INVENTOR(S) : Johann Schmitz and Ingo Hoffmann

Page 1 of 1

It is certified that error appears in the above-identified patent and that said Letters Patent is hereby corrected as shown below:

Title page, item [73] Assignee, delete "Schwabische Huttenwerke Automotive GmbH & Co. KG" to read as follows: --Schwäbische Hüttenwerke Automotive GmbH & Co. KG--

Signed and Sealed this

Twenty-fifth Day of May, 2010

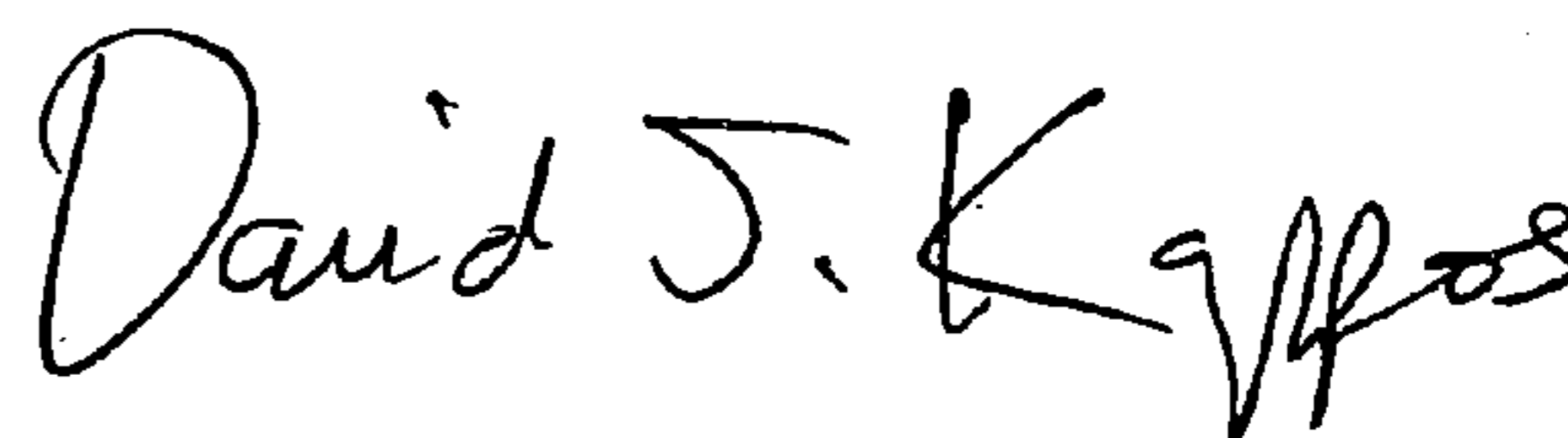
A handwritten signature in black ink that reads "David J. Kappos". The signature is written in a cursive, flowing style.

David J. Kappos
Director of the United States Patent and Trademark Office