

US00D602956S

(12) **United States Design Patent**
Herzer

(10) **Patent No.:** **US D602,956 S**

(45) **Date of Patent:** **** Oct. 27, 2009**

(54) **GAS POWERED INTERNAL COMBUSTION ENGINE FOR USE IN A LEAF BLOWER**

2005/0133354 A1* 6/2005 Watanabe et al. 200/334

* cited by examiner

(76) Inventor: **Bernardo J. Herzer**, 3863 Westwood Blvd., Culver City, CA (US) 90232

Primary Examiner—Ian Simmons

Assistant Examiner—Wan Laymon

(74) *Attorney, Agent, or Firm*—Don Finkelstein

(**) Term: **14 Years**

(57) **CLAIM**

(21) Appl. No.: **29/286,827**

What is claimed is the ornamental design for a gas powered internal combustion engine for use in a leaf blower, as shown and described.

(22) Filed: **May 21, 2007**

(51) **LOC (9) Cl.** **15-01**

(52) **U.S. Cl.** **D15/1**

(58) **Field of Classification Search** D15/1-5,
D15/14, 17; 123/192.1, 27 GE, 525, 557,
123/527, 195 R, 198 E

See application file for complete search history.

DESCRIPTION

FIG. 1 is a perspective view of my gas powered internal combustion engine for use in a leaf blower;

FIG. 2 is a right side elevational view of my gas powered internal combustion engine for use in a leaf blower;

FIG. 3 is a left side elevational view of my gas powered internal combustion engine for use in a leaf blower;

FIG. 4 is a top plan view of my gas powered internal combustion engine for use in a leaf blower;

FIG. 5 is a bottom plan view of my gas powered internal combustion engine for use in a leaf blower;

FIG. 6 is a front elevational view of my gas powered internal combustion engine for use in a leaf blower; and,

FIG. 7 is a rear elevational view of my gas powered internal combustion engine for use in a leaf blower.

The broken lines in the Figures are included for the purpose of illustrating a portion of the gas powered internal combustion engine for use in a leaf blower that forms no part of the claimed design.

(56) **References Cited**

U.S. PATENT DOCUMENTS

3,086,698	A *	4/1963	Goldstein	417/411
3,110,997	A *	11/1963	McClain	56/12.8
4,391,041	A *	7/1983	Porter-Bennett	30/296.1
4,815,430	A *	3/1989	Ueno et al.	123/195 R
D324,051	S *	2/1992	Tuggle et al.	D15/1
5,211,144	A *	5/1993	Collins et al.	123/198 E
D344,088	S *	2/1994	Tuggle et al.	D15/1
D355,198	S *	2/1995	Kikuchi	D15/1
D358,308	S *	5/1995	Griffin	D8/8
5,865,155	A *	2/1999	Nagashima	123/398
6,065,214	A *	5/2000	Nagashima	30/276
6,182,524	B1 *	2/2001	Nagashima	74/501.6
6,409,097	B1 *	6/2002	McCauley	239/289
6,837,447	B1 *	1/2005	Clark	239/318
6,857,413	B2 *	2/2005	Yamamoto	123/198 E
6,945,215	B2 *	9/2005	Kawamoto et al.	123/196 W

1 Claim, 7 Drawing Sheets

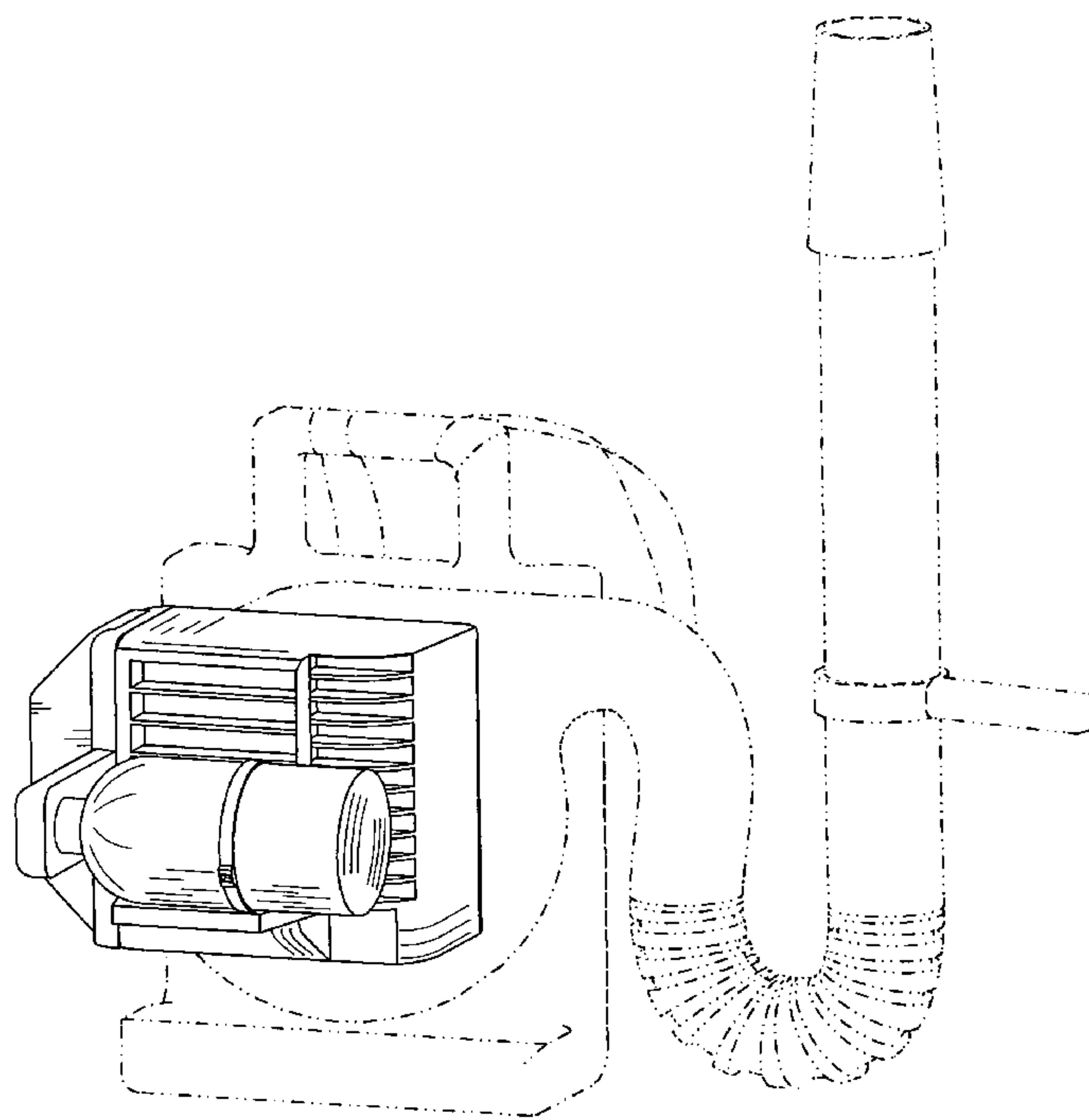

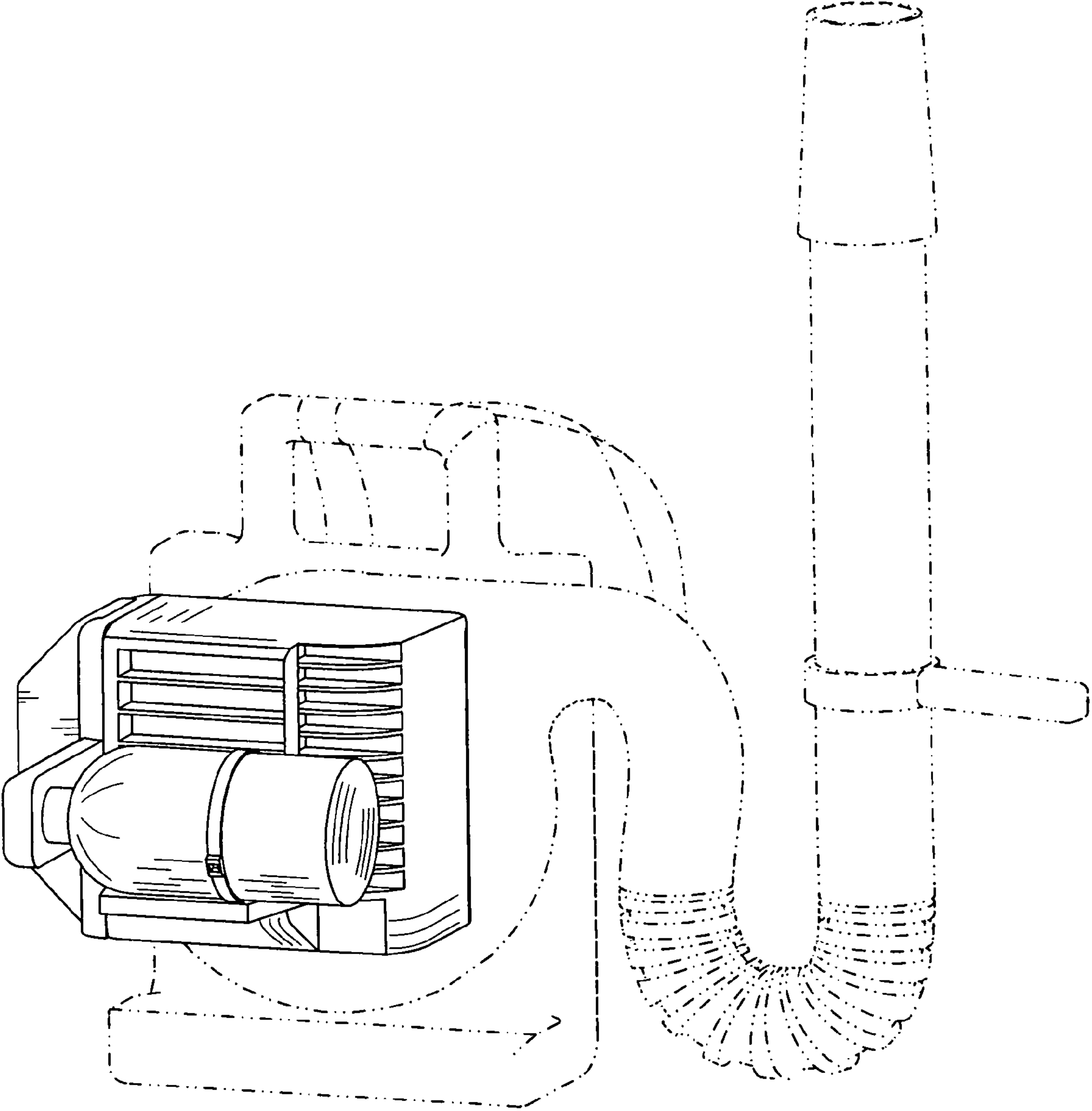

FIG.1

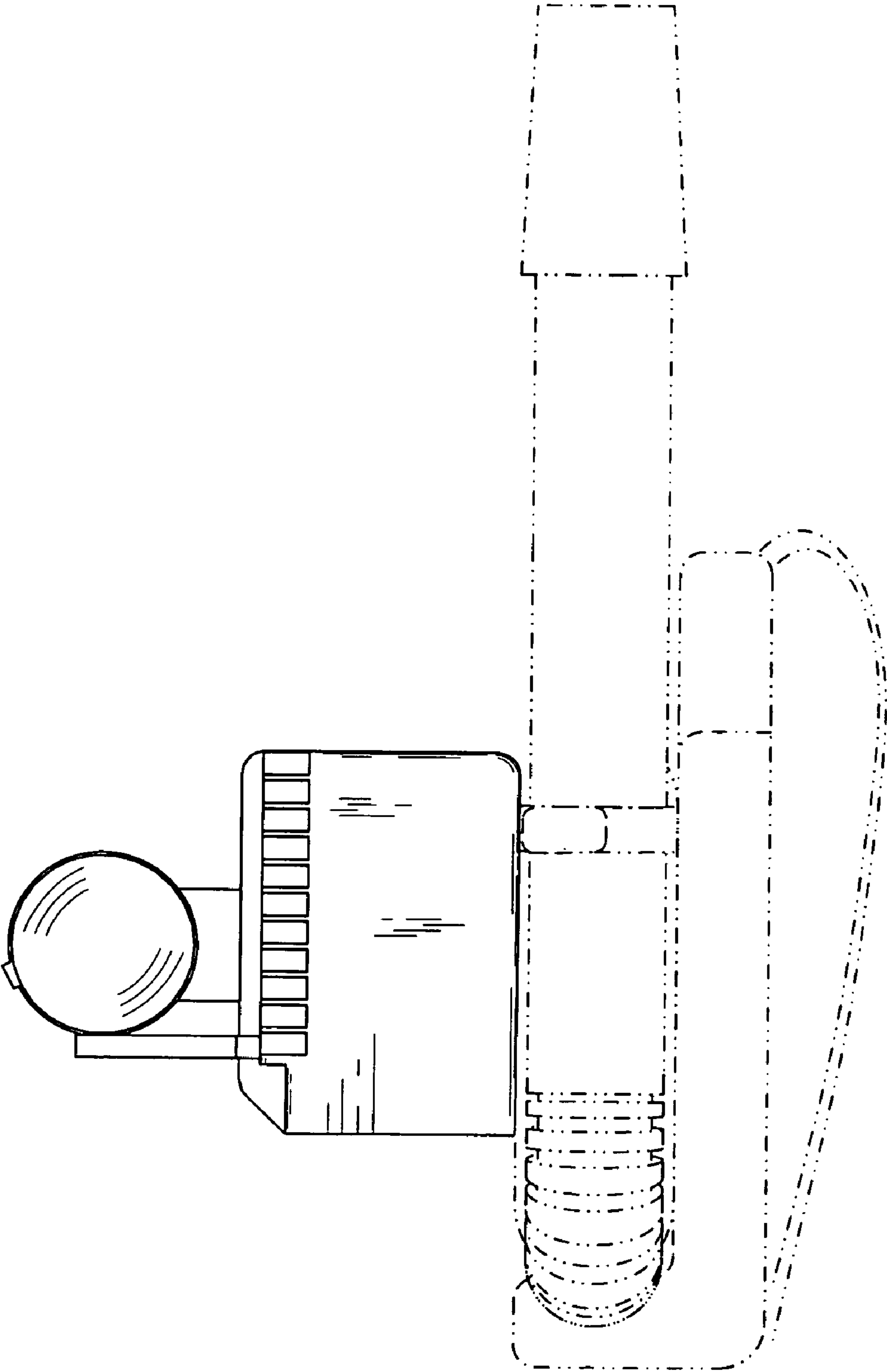

FIG.2

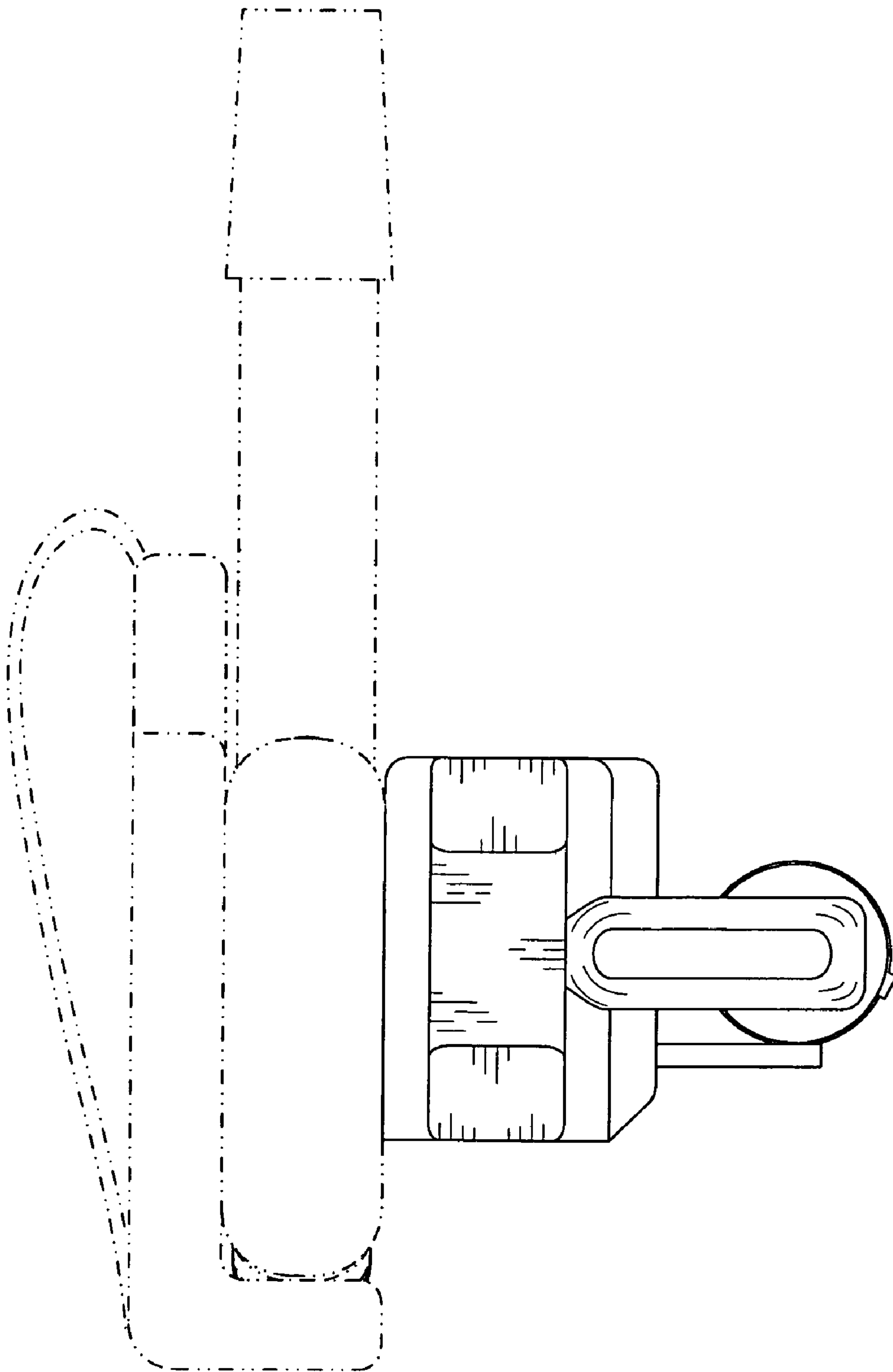

FIG.3

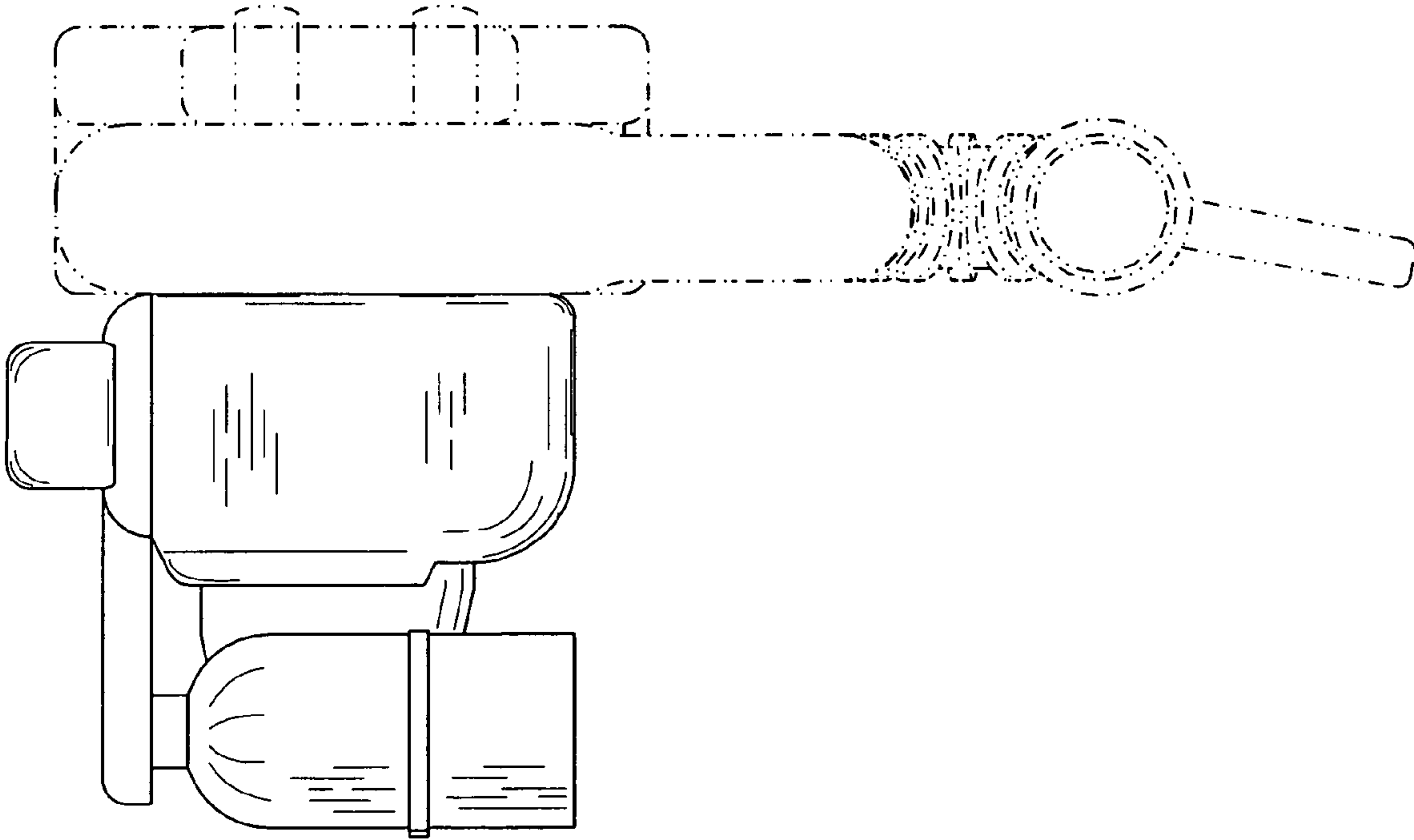

FIG.4

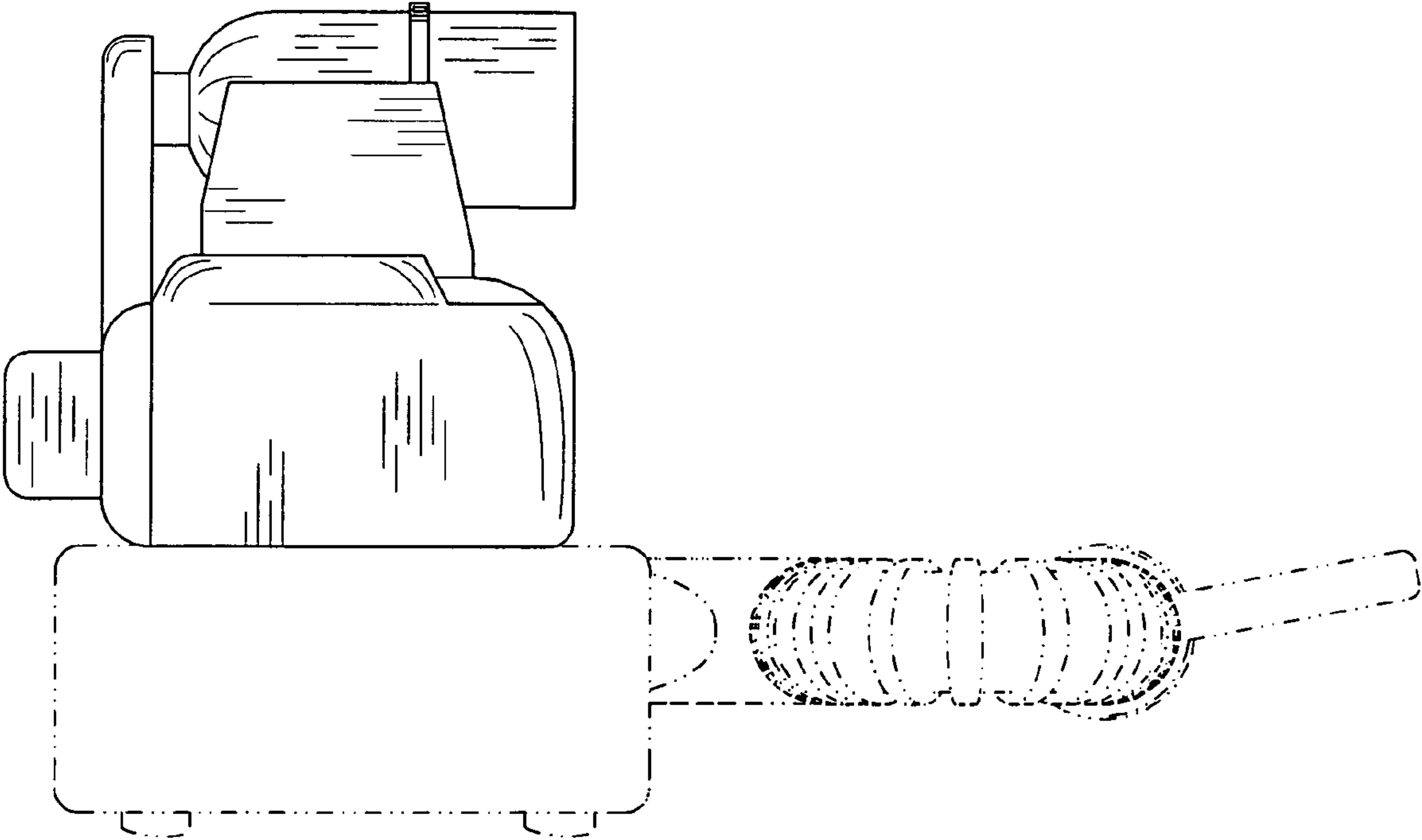

FIG.5

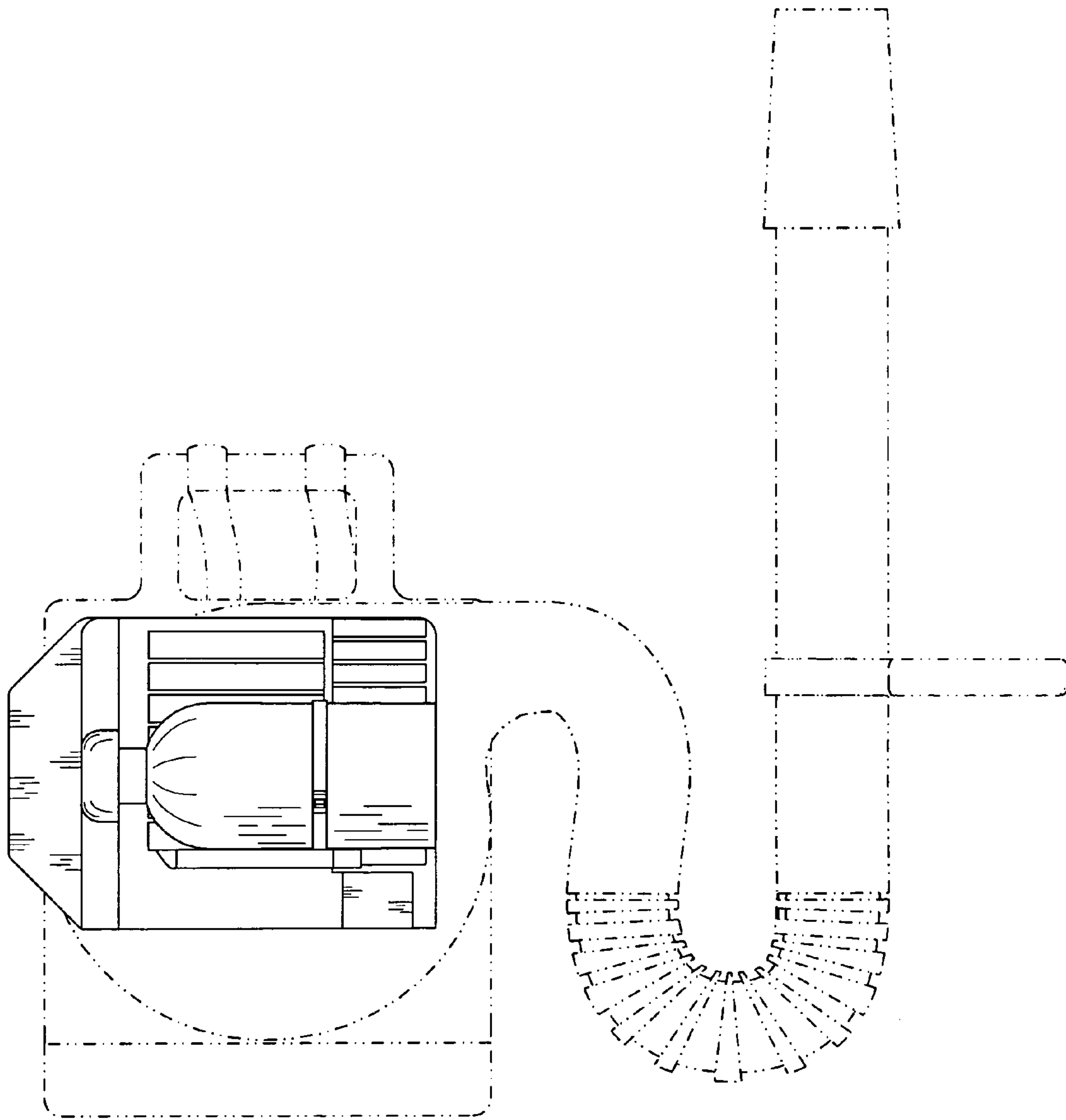

FIG.6

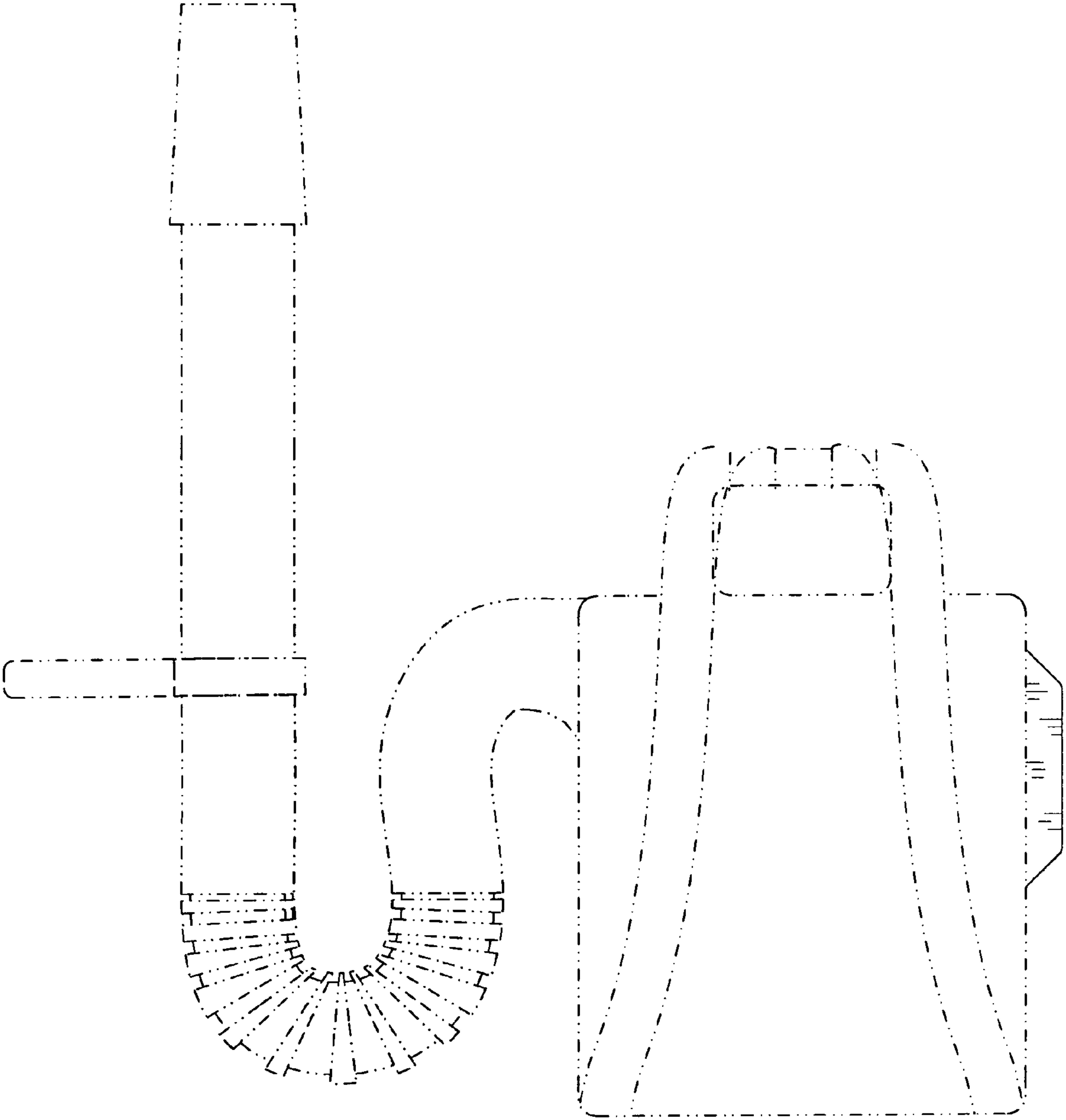

FIG. 7