



US00D602795S

(12) **United States Design Patent**
Oshima

(10) **Patent No.:** **US D602,795 S**

(45) **Date of Patent:** **** Oct. 27, 2009**

(54) **FLOW SENSOR**

(75) Inventor: **Yuta Oshima**, Tsukubamirai (JP)

(73) Assignee: **SMC Corporation**, Chiyoda-ku, Tokyo (JP)

(**) Term: **14 Years**

(21) Appl. No.: **29/335,961**

(22) Filed: **Apr. 24, 2009**

(30) **Foreign Application Priority Data**

Nov. 28, 2008 (JP) 2008-030514

(51) **LOC (9) Cl.** **10-04**

(52) **U.S. Cl.** **D10/96**

(58) **Field of Classification Search** D10/96;
73/201, 273, 204.21, 861.63, 861.64, 861.351-861.357
See application file for complete search history.

(56) **References Cited**

U.S. PATENT DOCUMENTS

D440,896 S * 4/2001 Asai et al. D10/96

D447,072 S * 8/2001 Asai et al. D10/96

* cited by examiner

Primary Examiner—Antoine D Davis

(74) *Attorney, Agent, or Firm*—Yokoi & Co., U.S.A., Inc.; Peter Ganjian

(57) **CLAIM**

The ornamental design for a flow sensor, as shown and described.

DESCRIPTION

FIG. 1 shows a front view of a flow sensor showing my new design;

FIG. 2 shows a rear view thereof;

FIG. 3 shows a right side view thereof;

FIG. 4 shows a left side view thereof;

FIG. 5 shows a top view thereof;

FIG. 6 shows a bottom view thereof;

FIG. 7 shows a top, front and left side perspective view thereof; and,

FIG. 8 shows a partial cross-sectional view thereof, taken along line 8—8 in FIG. 5.

1 Claim, 4 Drawing Sheets

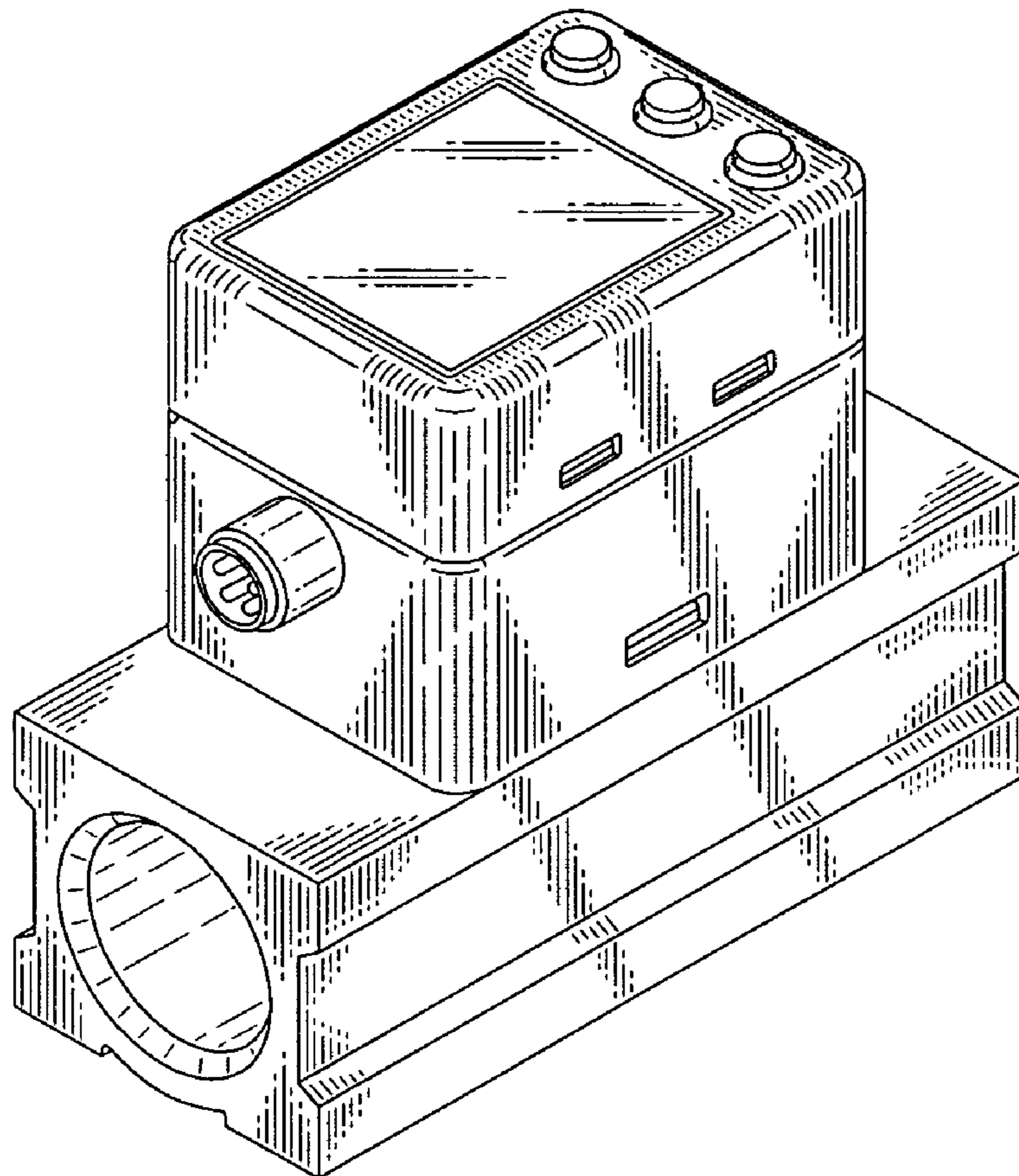

FIG. 1

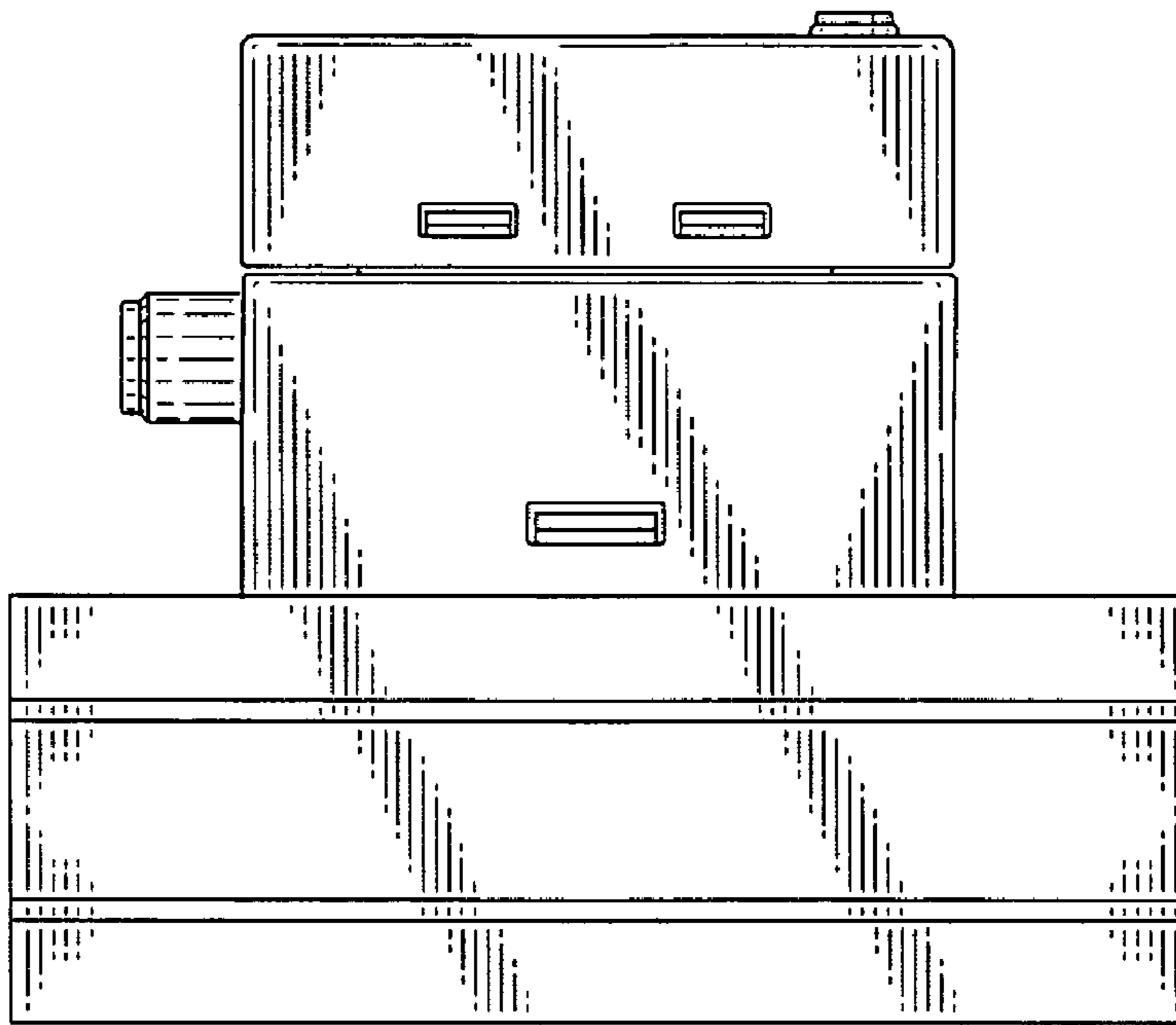

FIG. 2

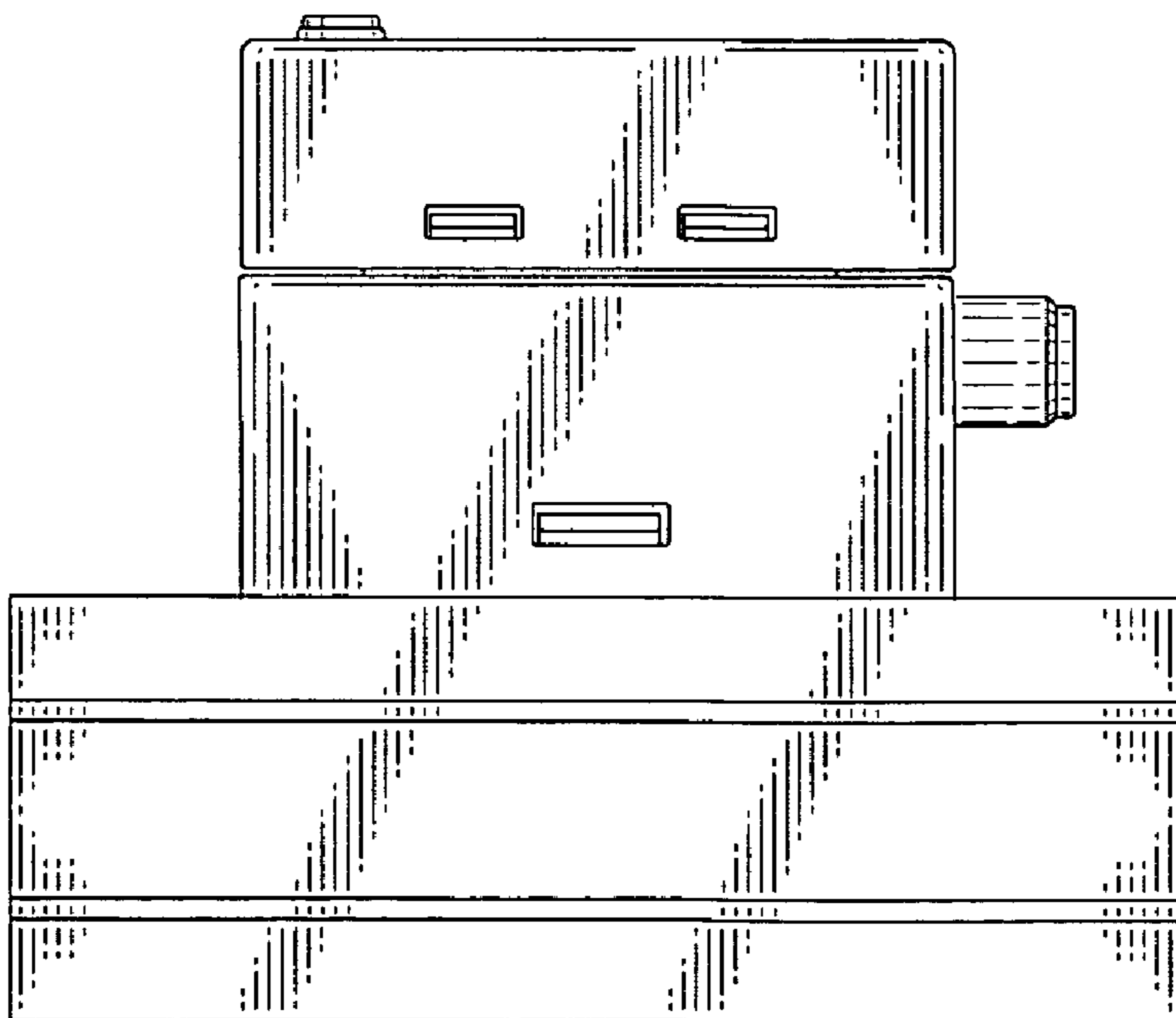

FIG. 3

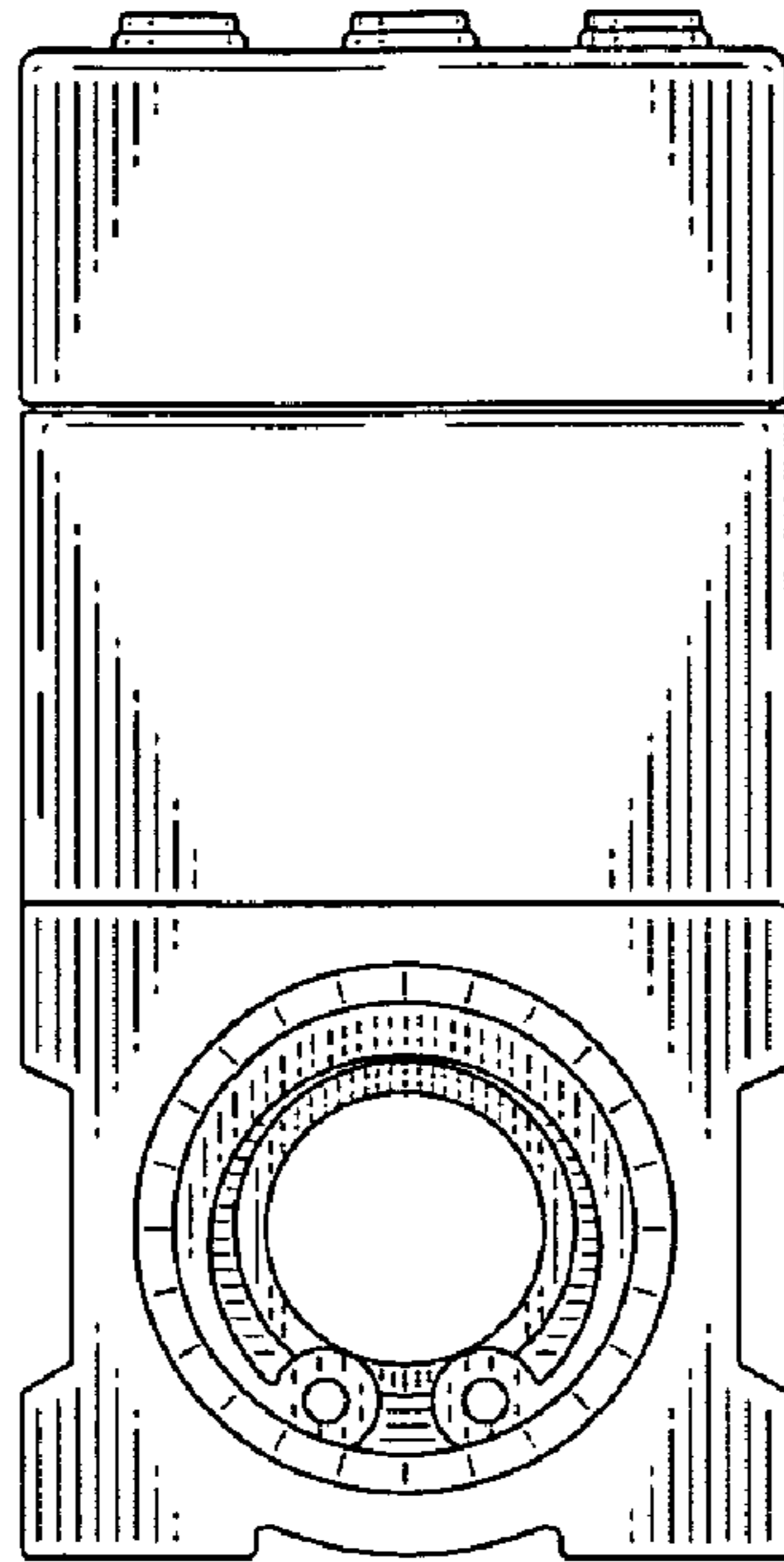

FIG. 4

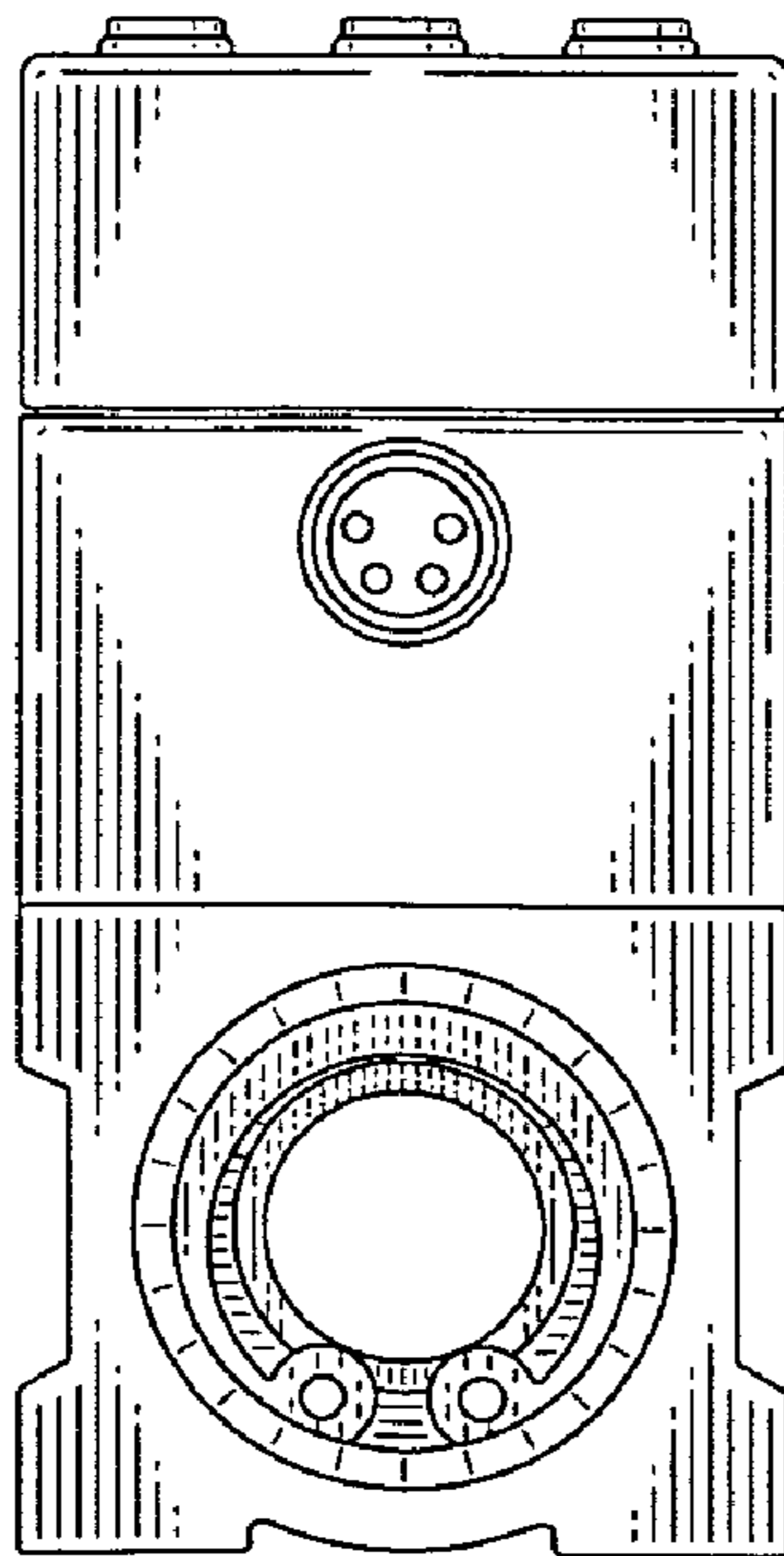

FIG. 5

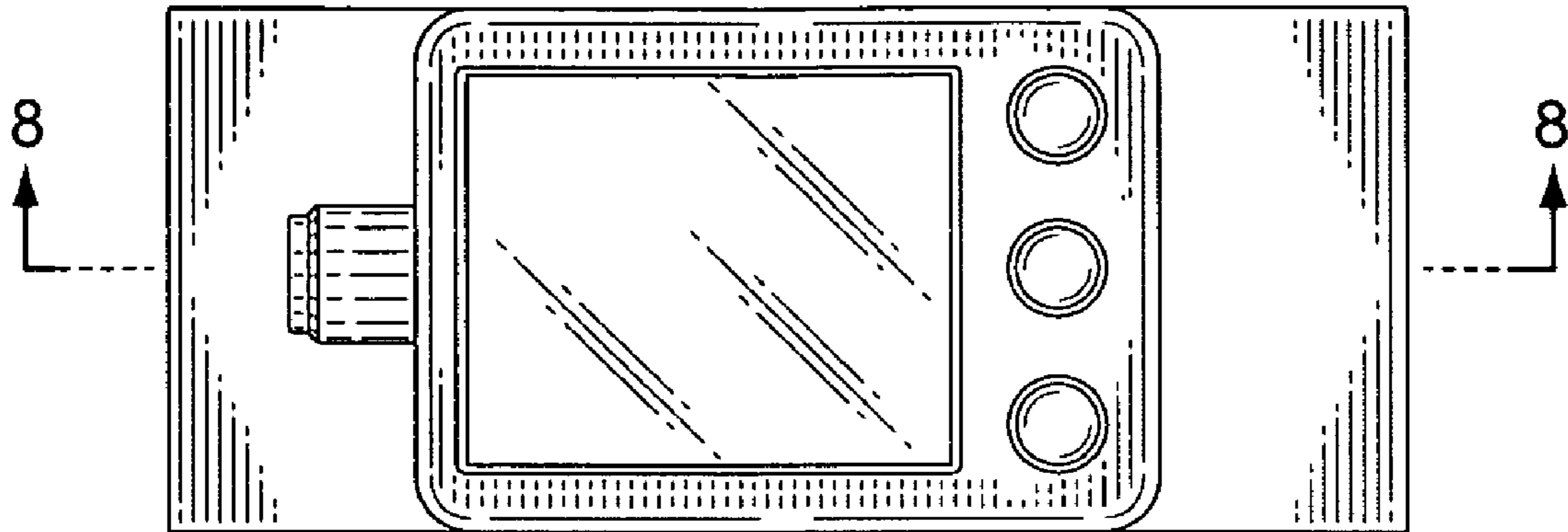

FIG. 6

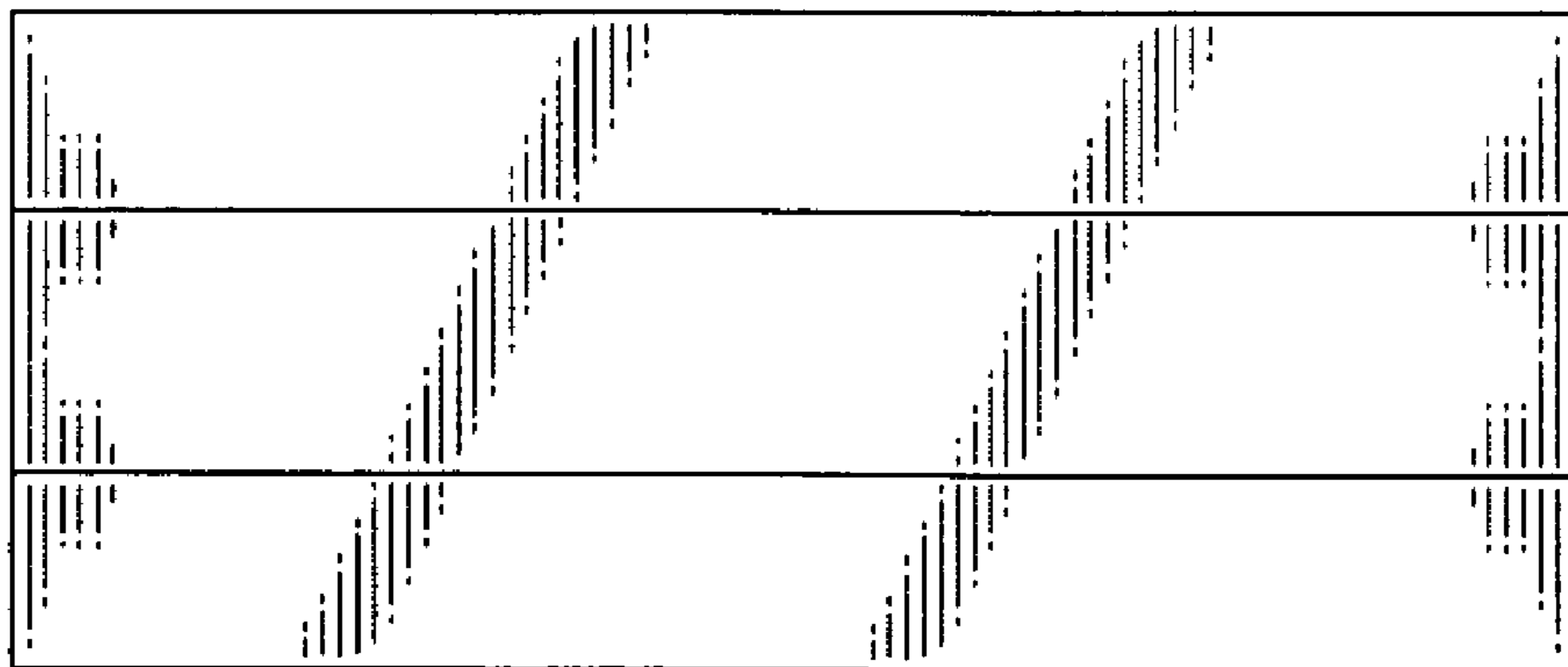

FIG. 7

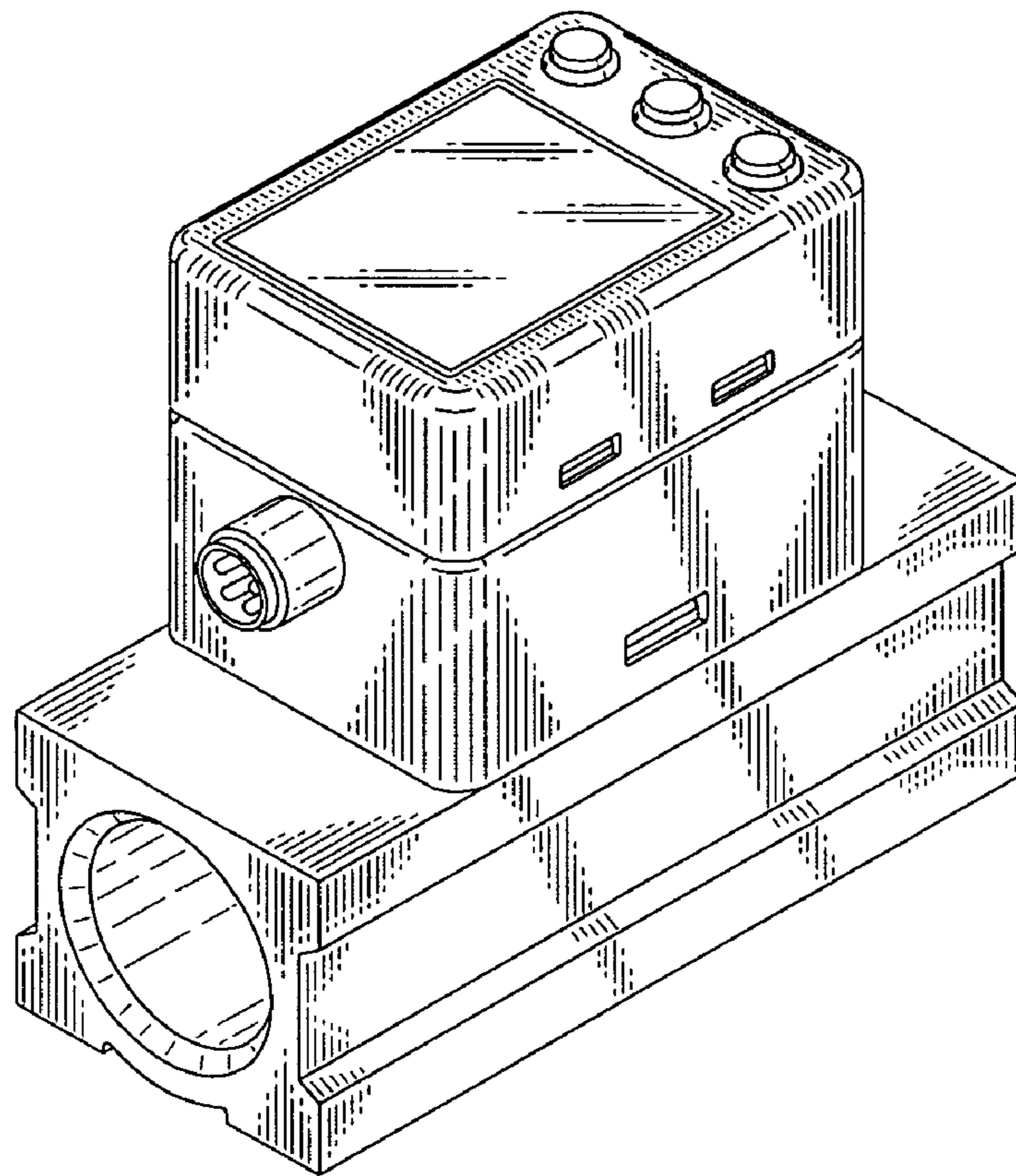

FIG. 8

