



US00D602702S

(12) **United States Design Patent**
Saint-Jalmes et al.

(10) **Patent No.:** **US D602,702 S**
(45) **Date of Patent:** **** Oct. 27, 2009**

(54) **AIRCRAFT SEAT**

(75) Inventors: **Bruno Saint-Jalmes**, Toulouse (FR);
Jason Zaneboni, Blagnac (FR);
Bernard Rumeau, Cornebarrieu (FR)

(73) Assignee: **Airbus SAS**, Blagnac Cedex (FR)

(**) Term: **14 Years**

(21) Appl. No.: **29/281,145**

(22) Filed: **Jun. 15, 2007**

(51) **LOC (9) Cl.** **06-01**

(52) **U.S. Cl.** **D6/356**

(58) **Field of Classification Search** D6/356,
D6/334-336, 367-368, 374-375, 500-502;
297/232, 391, 452.21, 452.24, 452.25, 354.1
See application file for complete search history.

(56) **References Cited**

U.S. PATENT DOCUMENTS

D354,629 S *	1/1995	Chapman	D6/356
D384,212 S *	9/1997	Infanti	D6/360
D420,818 S *	2/2000	Lieberman et al.	D6/358
D439,425 S *	3/2001	Park et al.	D6/356
D504,579 S *	5/2005	Beermann et al.	D6/356
D506,084 S *	6/2005	Beermann et al.	D6/356
D507,122 S *	7/2005	Beermann	D6/356
D508,337 S *	8/2005	Stalmate et al.	D6/356
D509,077 S *	9/2005	Beermann et al.	D6/356
D516,328 S *	3/2006	Stalmate et al.	D6/356
D534,005 S *	12/2006	Beermann	D6/356
D535,485 S *	1/2007	Moburg	D6/356
D536,185 S *	2/2007	Ritzel	D6/356
D536,887 S *	2/2007	Goebert et al.	D6/356
D574,619 S *	8/2008	Maezono	D6/356

OTHER PUBLICATIONS

U.S. Appl. No. 29/281,139. Title: Aircraft Lighting Effect, filed Jun. 15, 2007.

U.S. Appl. No. 29/281,143. Title: Aircraft Ceiling, filed Jun. 15, 2007.

U.S. Appl. No. 29/281,157. Title: Aircraft Furniture, filed Jun. 15, 2007.

U.S. Appl. No. 29/281,141. Title: Aircraft Module, filed Jun. 15, 2007.

* cited by examiner

Primary Examiner—Elizabeth A Albert

Assistant Examiner—Kelley A Donnelly

(74) *Attorney, Agent, or Firm*—Olser, Hoskin & Harcourt LLP

(57) **CLAIM**

The ornamental design for an aircraft seat, as shown and described.

DESCRIPTION

FIG. 1 is a perspective view showing an aircraft seat according to our design, taken from a rear, right side;

FIG. 2 is a rear elevational view thereof;

FIG. 3 is a front elevational view thereof;

FIG. 4 is a left side elevational view thereof;

FIG. 5 is a right side elevational view thereof;

FIG. 6 is a top plan view thereof; and,

FIG. 7 is an additional perspective view thereof, taken from a rear, right side, showing the seat in an aircraft.

Throughout the Figures, the dashed broken lines represent environmental matter and/or unclaimed portions of the aircraft seat and form no part of the claimed design. The dash-dot broken lines represent the boundary between claimed and unclaimed areas and form no part of the claimed design.

1 Claim, 7 Drawing Sheets

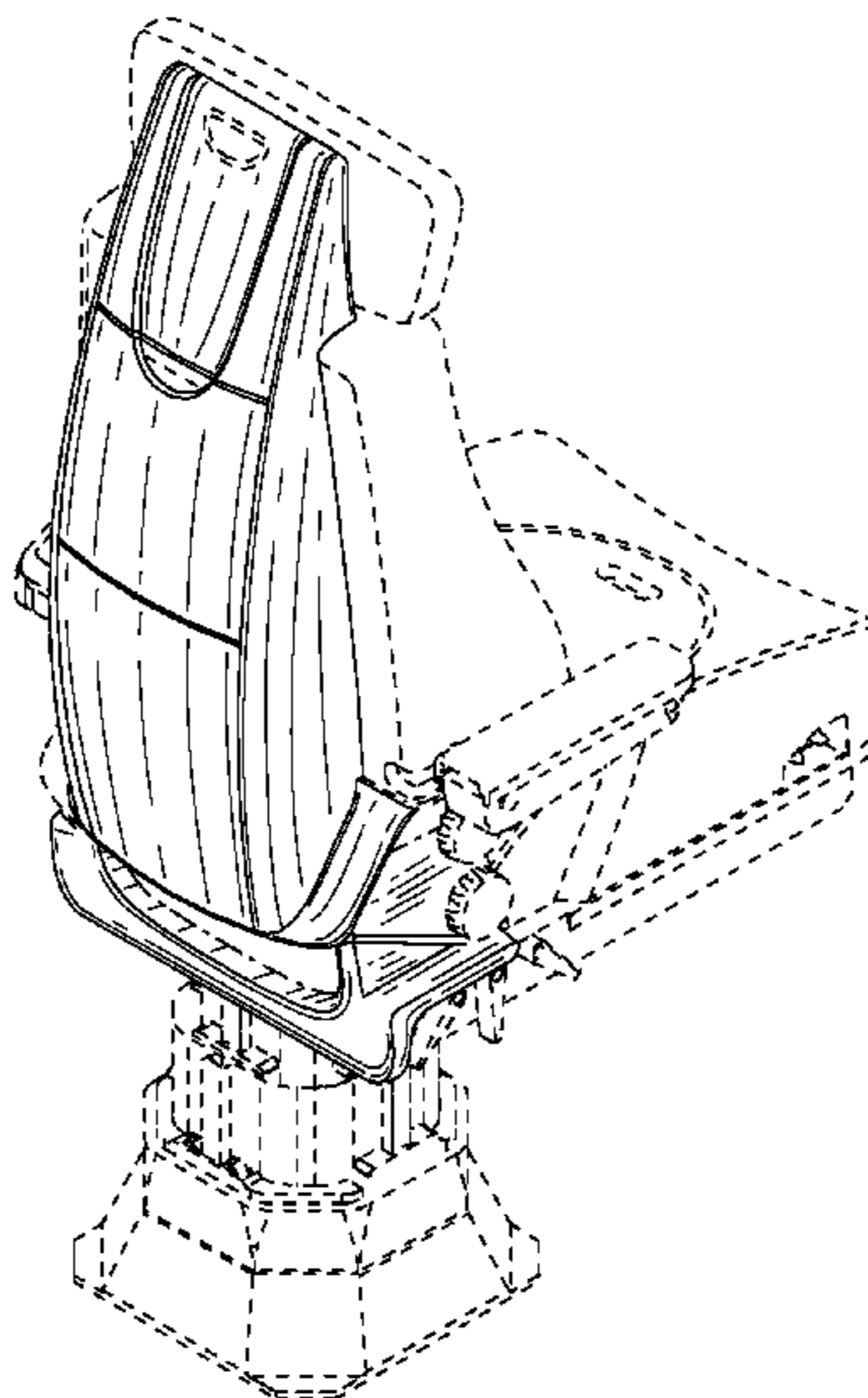

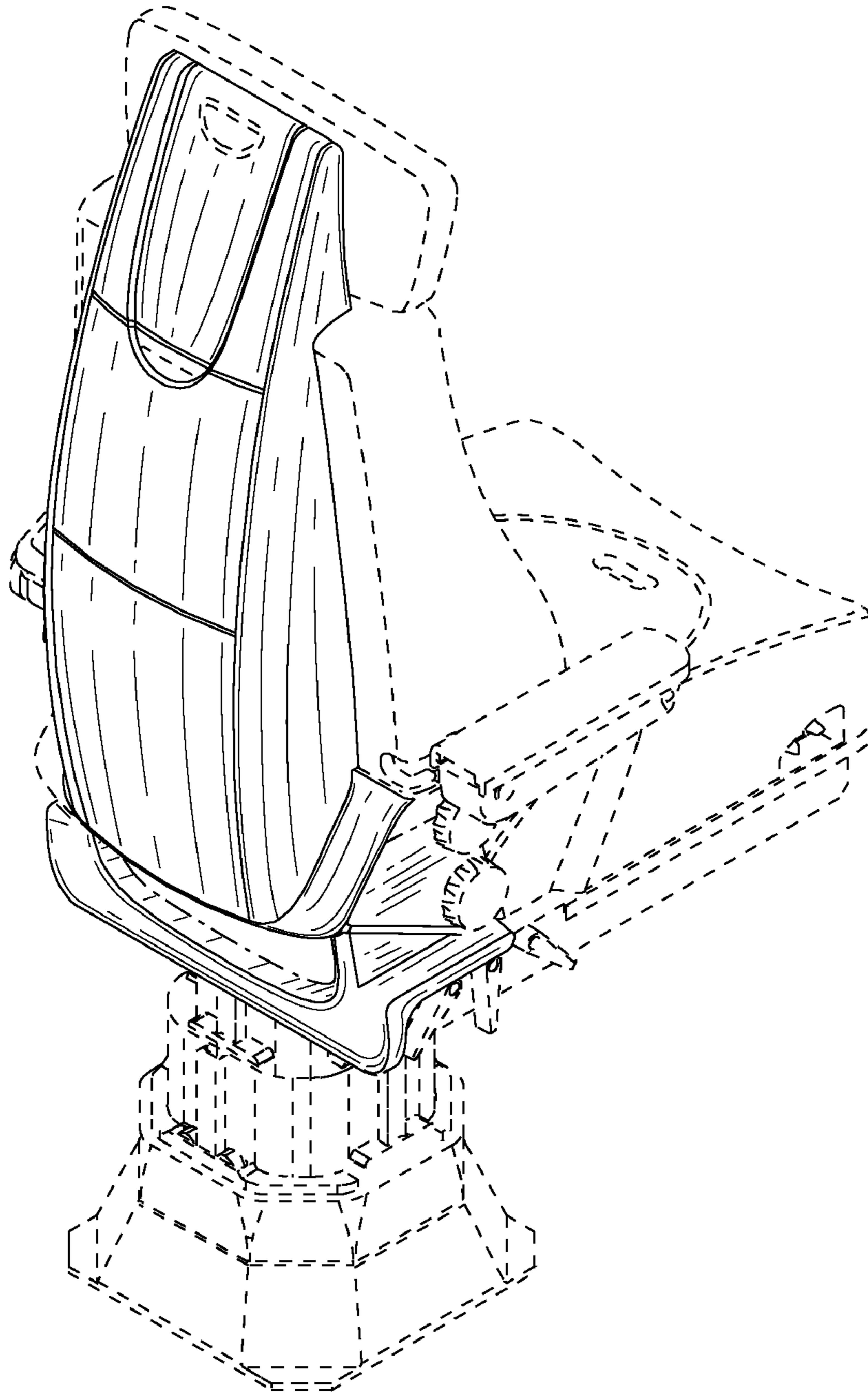

FIG. 1

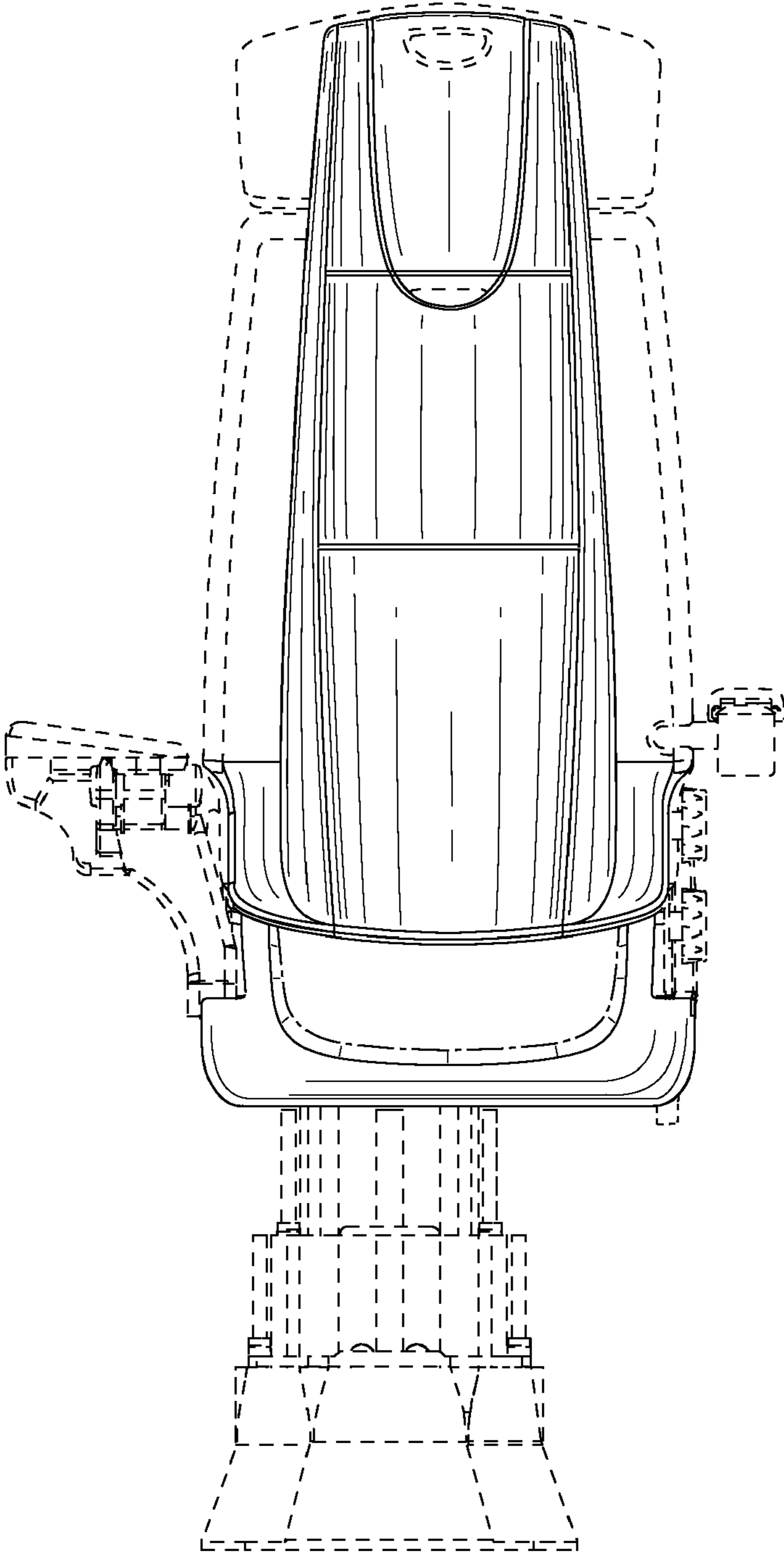

FIG. 2

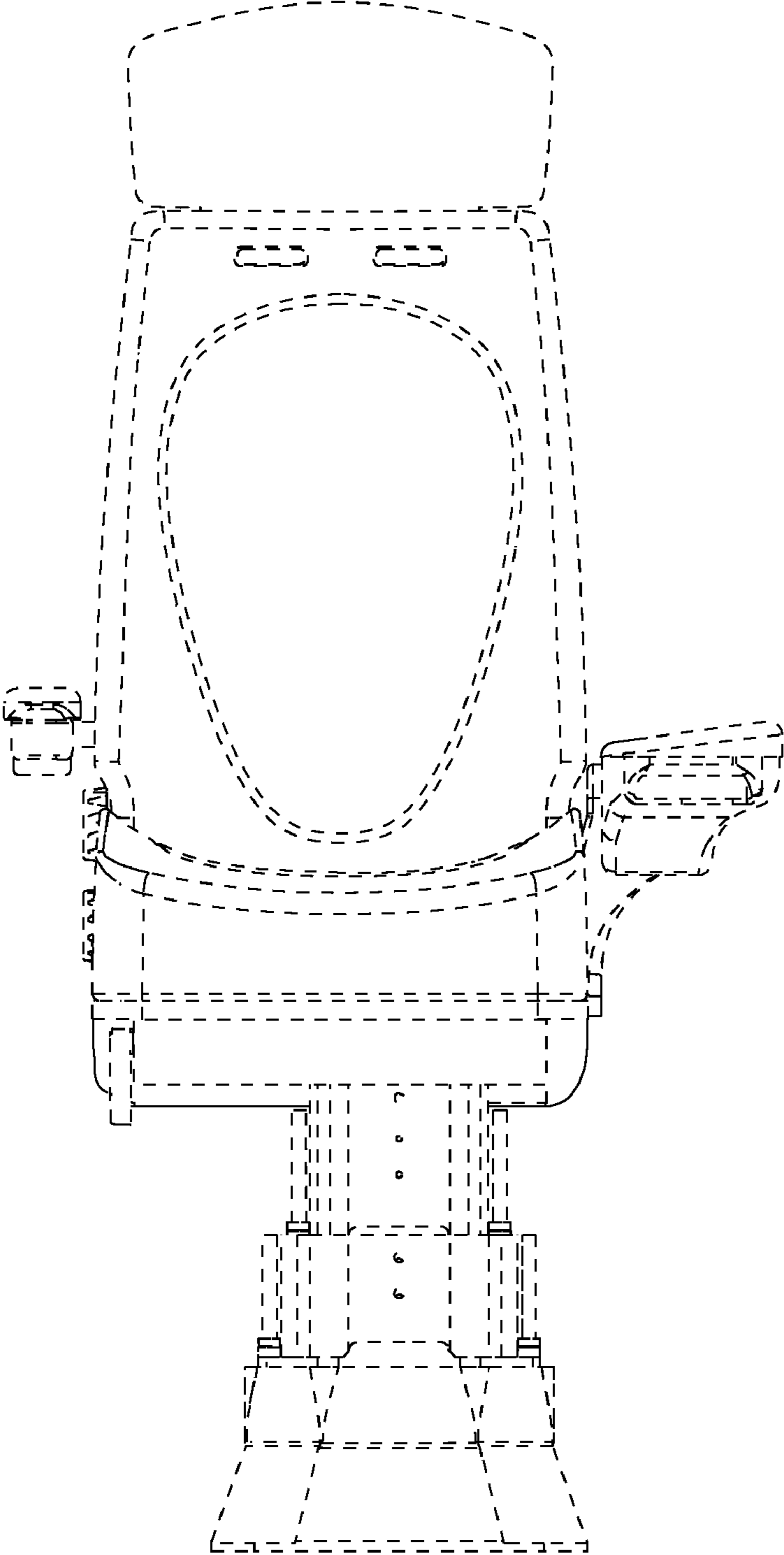

FIG. 3

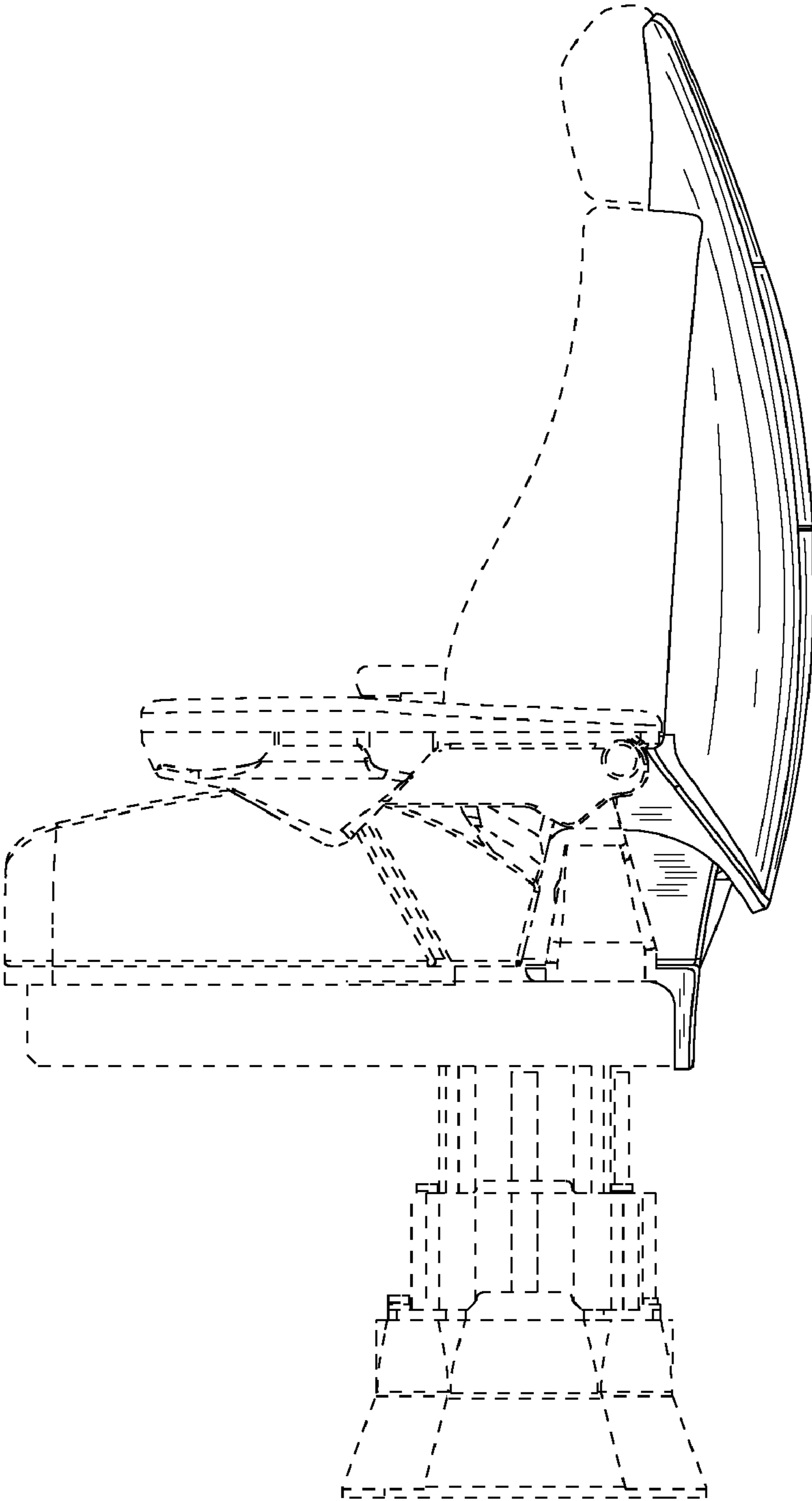

FIG. 4

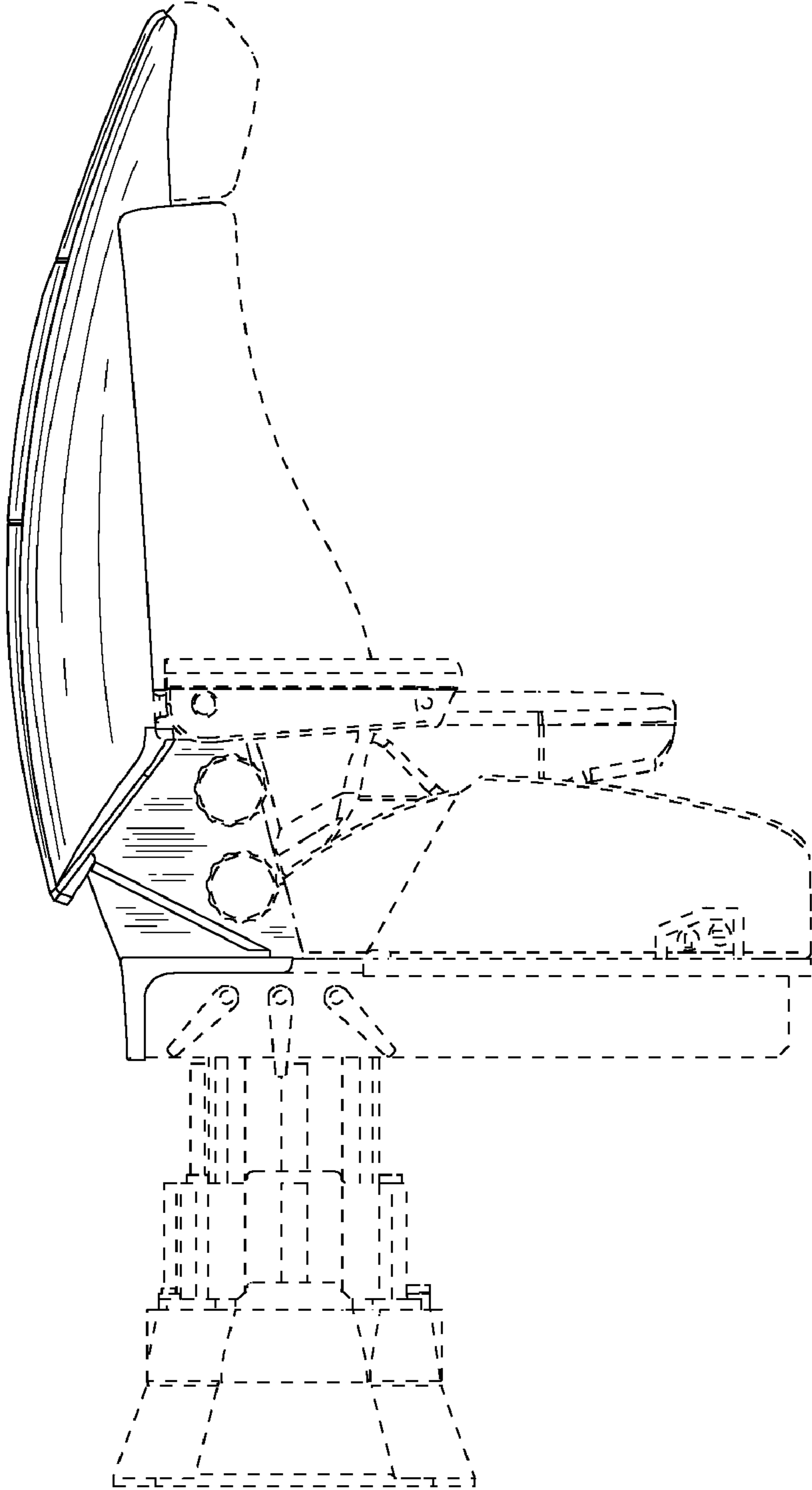

FIG. 5

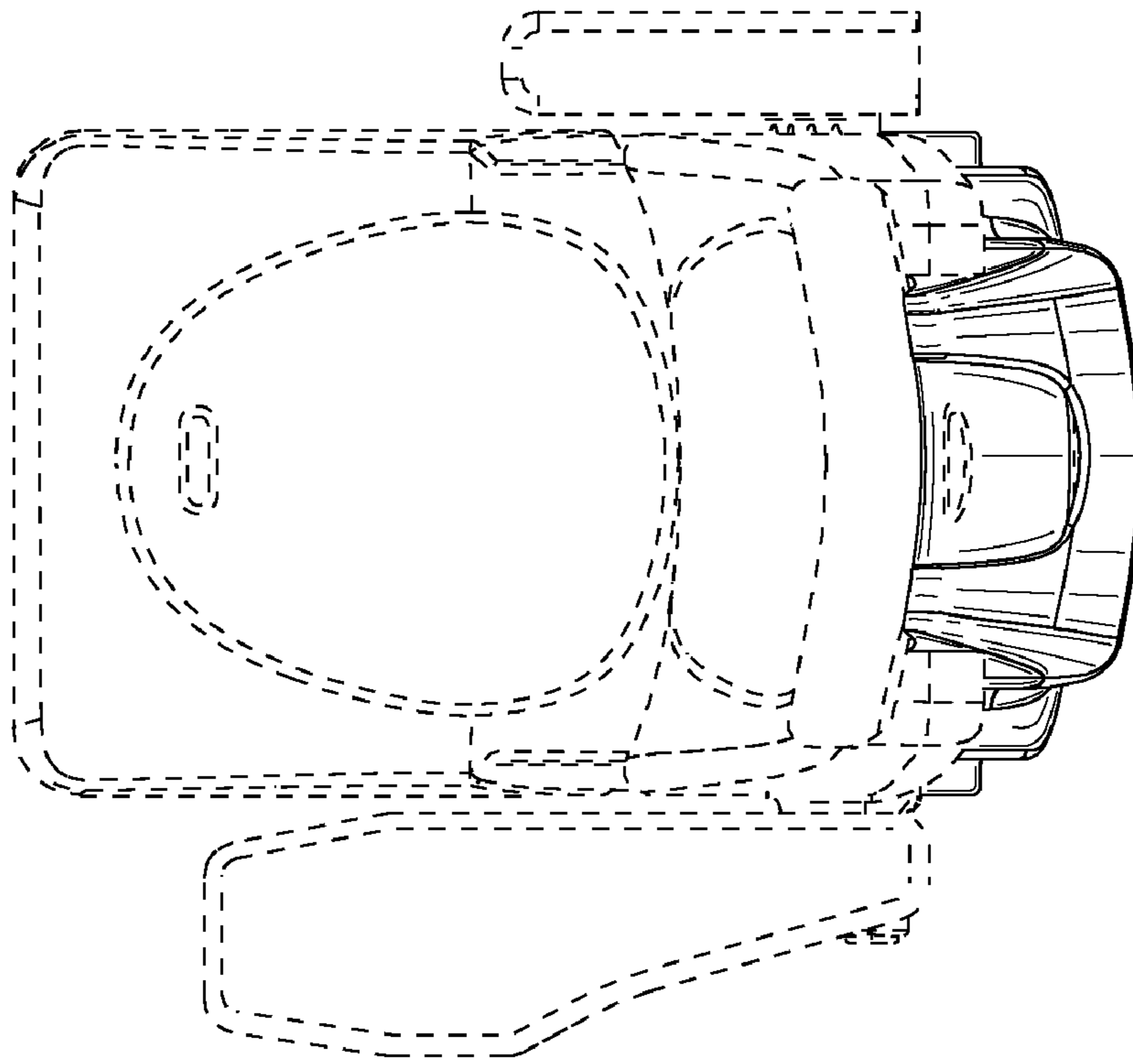

FIG. 6

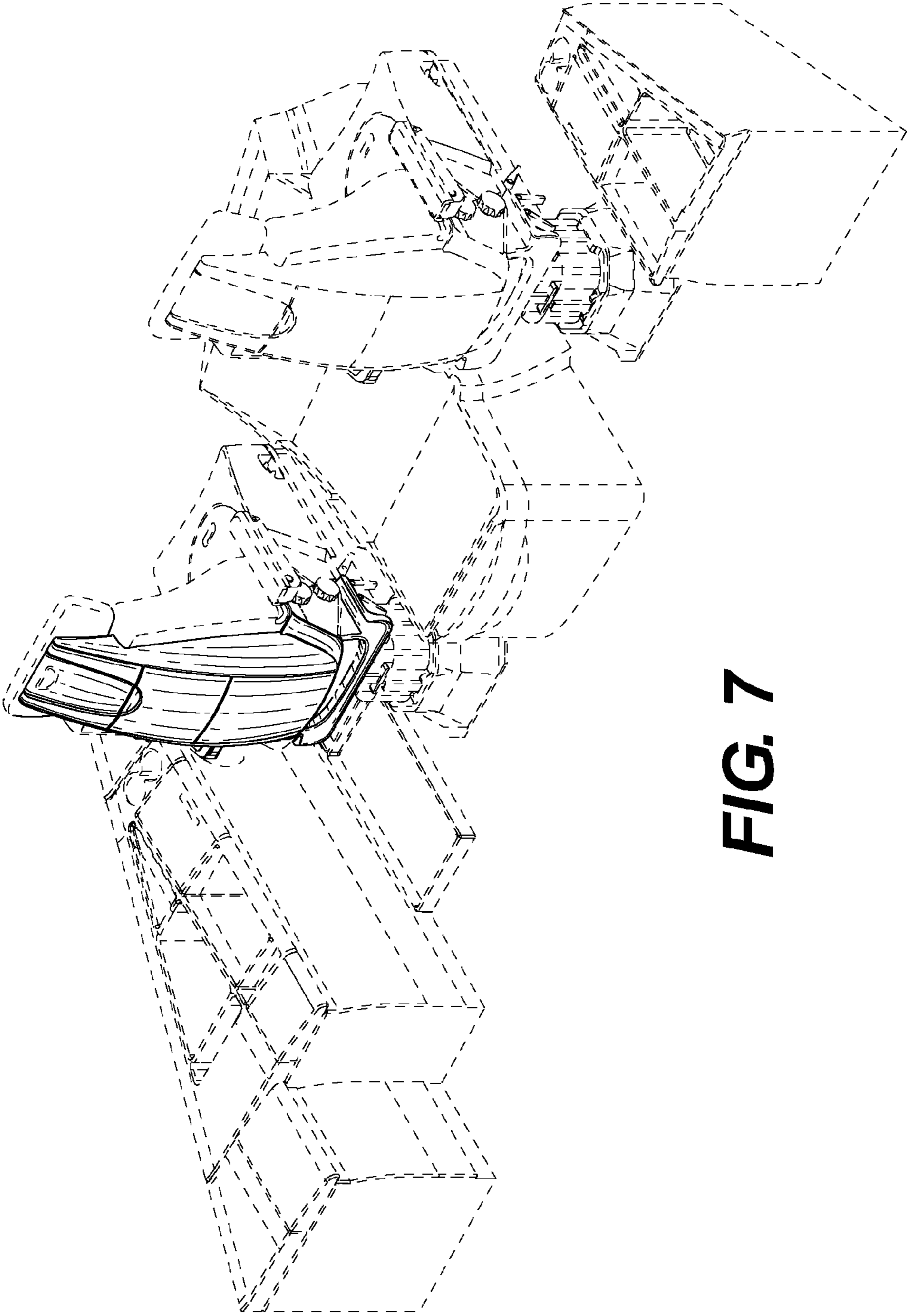

FIG. 7