



US00D602553S

(12) **United States Design Patent**  
**Wright**

(10) **Patent No.:** **US D602,553 S**  
(45) **Date of Patent:** **\*\* Oct. 20, 2009**

(54) **BASEBALL TRAINING DEVICE**

(76) Inventor: **Terry Joseph Wright**, 819 Coolwater Ct., Fort Mill, SC (US) 29715

(\*\*) Term: **14 Years**

(21) Appl. No.: **29/326,603**

(22) Filed: **Oct. 21, 2008**

(51) **LOC (9) Cl.** ..... **21-02**

(52) **U.S. Cl.** ..... **D21/780**

(58) **Field of Classification Search** ..... D21/698,  
D21/706, 780; 473/415-504; 434/247, 252  
See application file for complete search history.

(56) **References Cited**

U.S. PATENT DOCUMENTS

3,372,930	A *	3/1968	Sertich	.....	473/452
4,194,735	A *	3/1980	Wilson	.....	473/452
4,225,133	A *	9/1980	Kiray	.....	473/457
4,516,772	A	5/1985	Stratton		
4,998,720	A *	3/1991	Kim	.....	482/130
5,037,094	A	8/1991	Johnson		
5,076,580	A	12/1991	Lang		
5,385,343	A *	1/1995	Davis, Sr.	.....	473/452
5,613,677	A	3/1997	Walker, Jr.		
5,810,673	A	9/1998	Castleberry		
D399,280	S	10/1998	Griffin		

5,976,026	A	11/1999	Erb		
6,926,625	B1	8/2005	Fruechting		
7,125,350	B1	10/2006	Reason-Kerkhoff		
D533,247	S *	12/2006	Weeks	.....	D21/780
7,335,117	B2	2/2008	Reason-Kerkhoff		
2006/0142099	A1 *	6/2006	Trucks	.....	473/452

\* cited by examiner

*Primary Examiner*—Catherine Tuttle

(74) *Attorney, Agent, or Firm*—Hammer & Associates, P.C.

(57) **CLAIM**

The ornamental design for a baseball training device, as shown and described.

**DESCRIPTION**

FIG. 1 is a perspective view of baseball training device showing my new design;

FIG. 2 is a side elevational view thereof;

FIG. 3 is a top plan view thereof;

FIG. 4 is a bottom plan view thereof;

FIG. 5 is an end elevational view thereof

FIG. 6 is an elevational view of the end opposite to FIG. 5; and,

FIG. 7 is an exploded perspective view thereof.

**1 Claim, 4 Drawing Sheets**

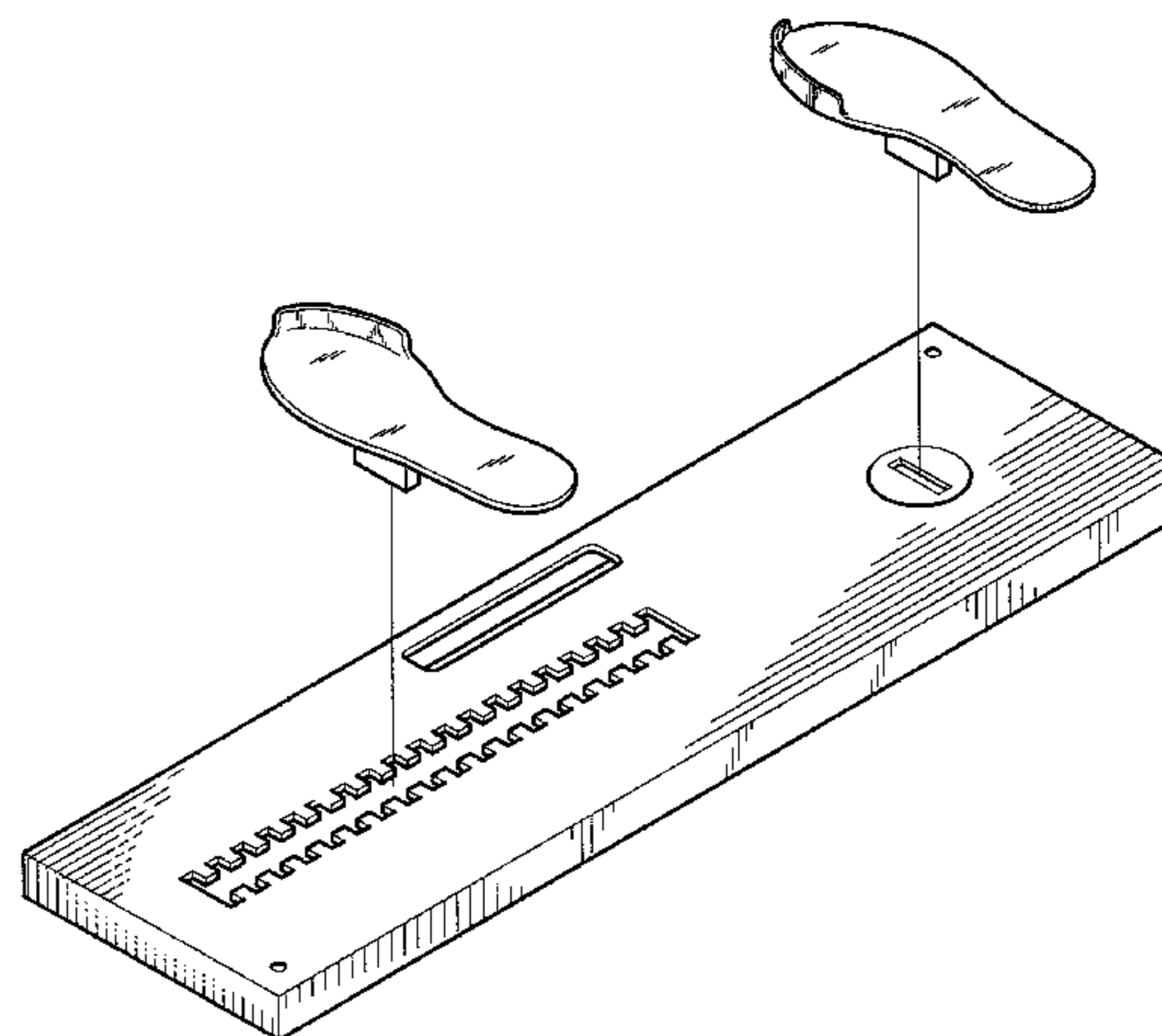
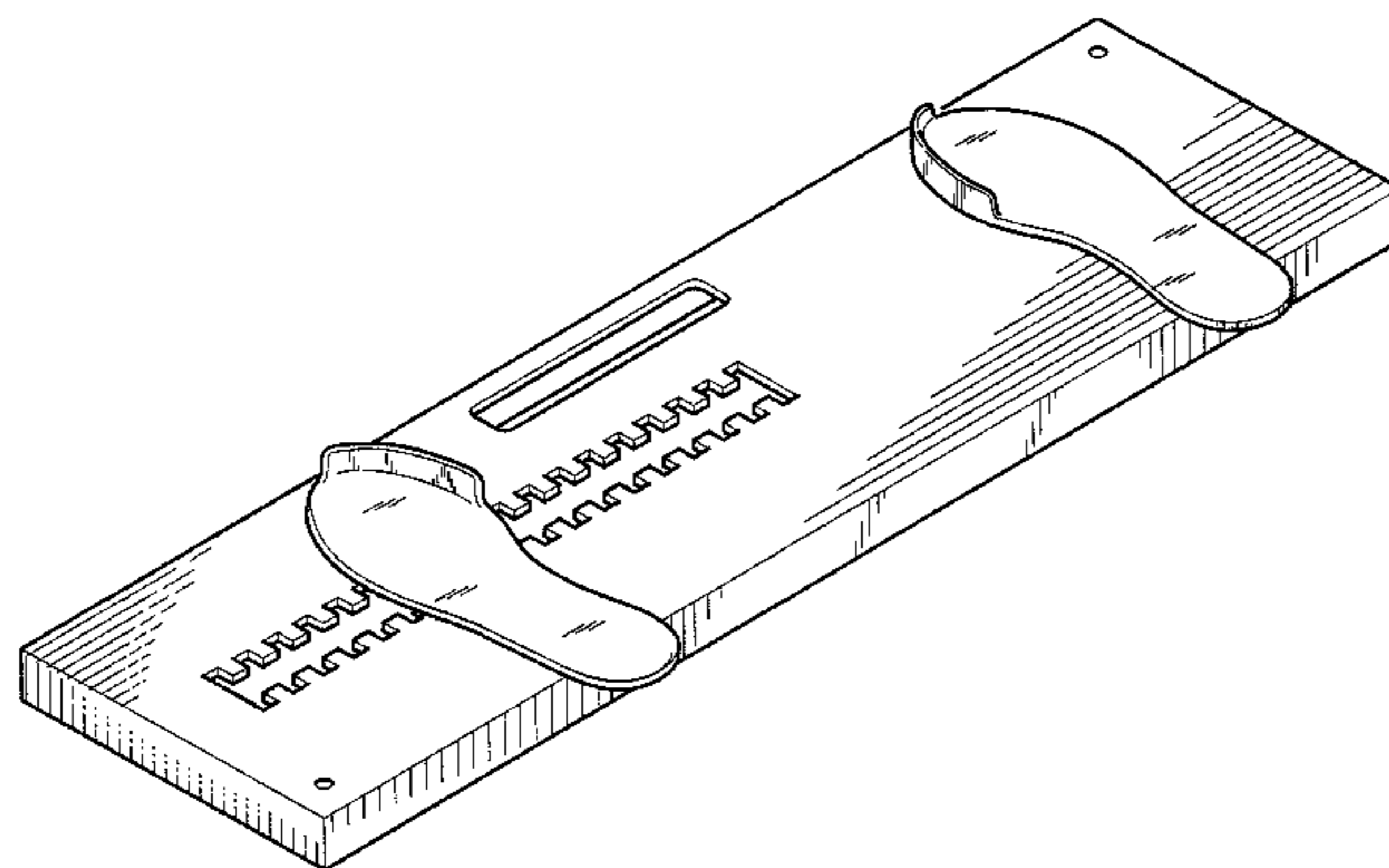

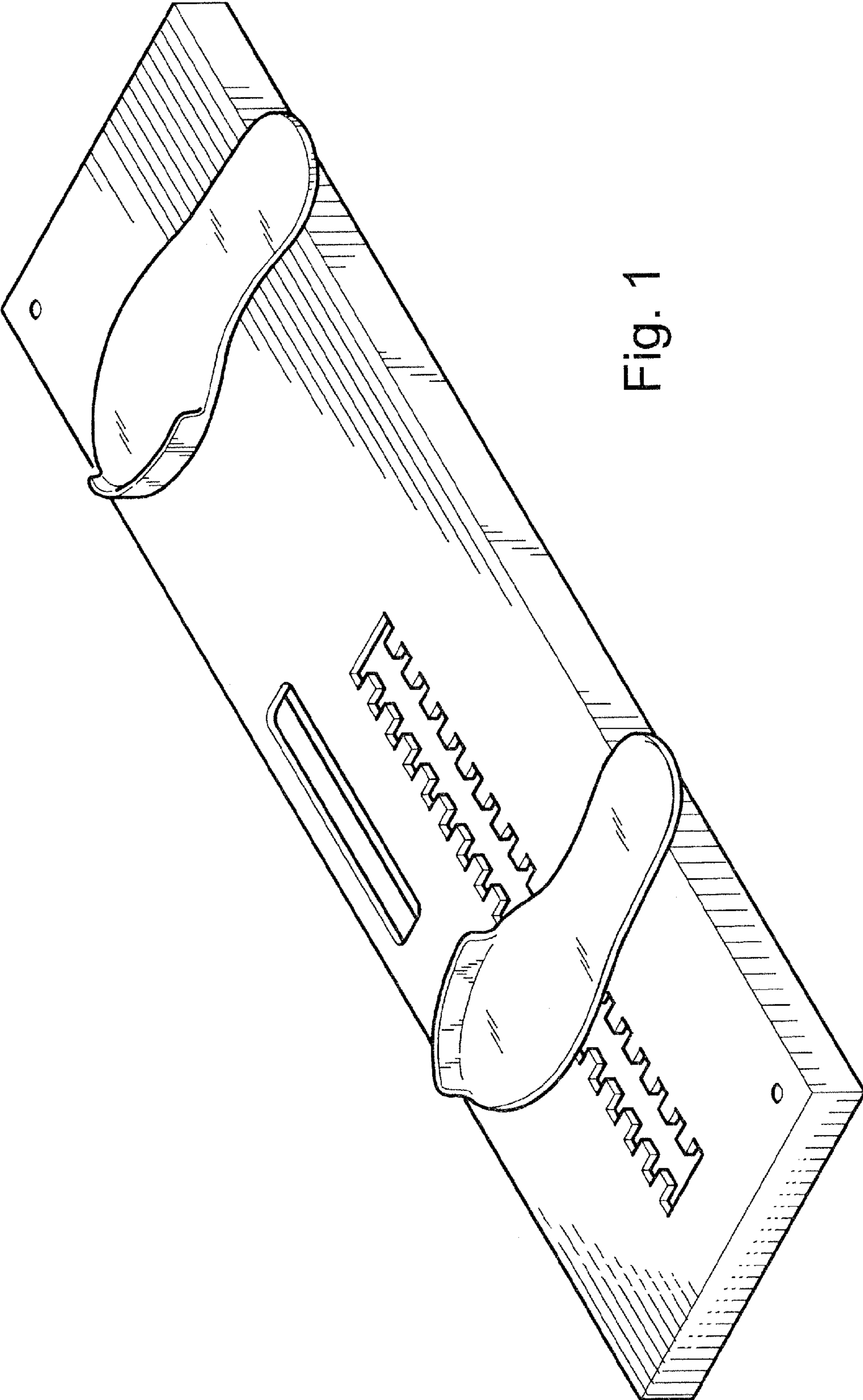
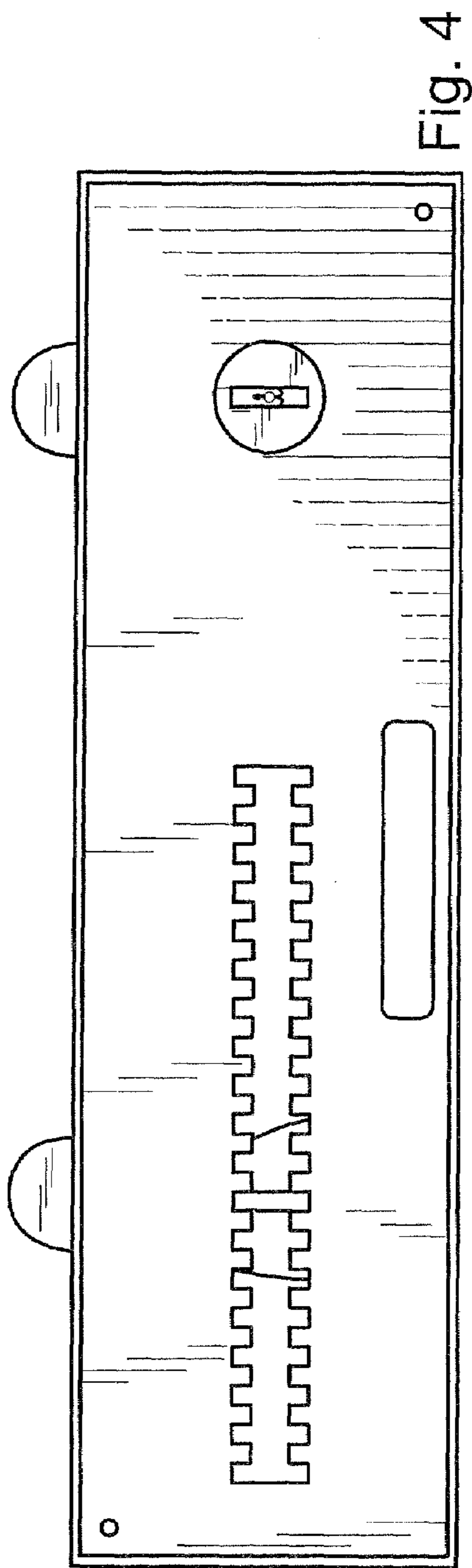
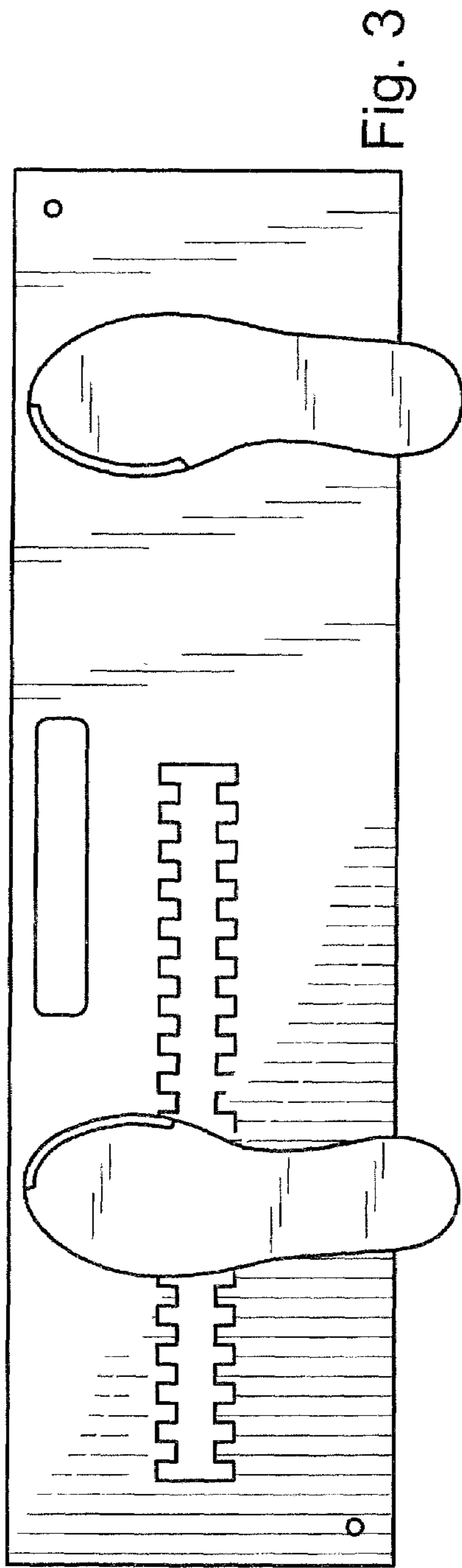
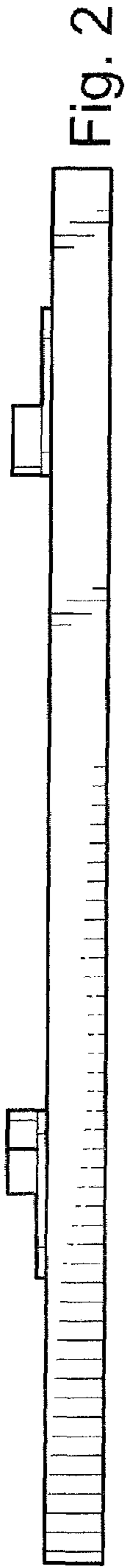

Fig. 1



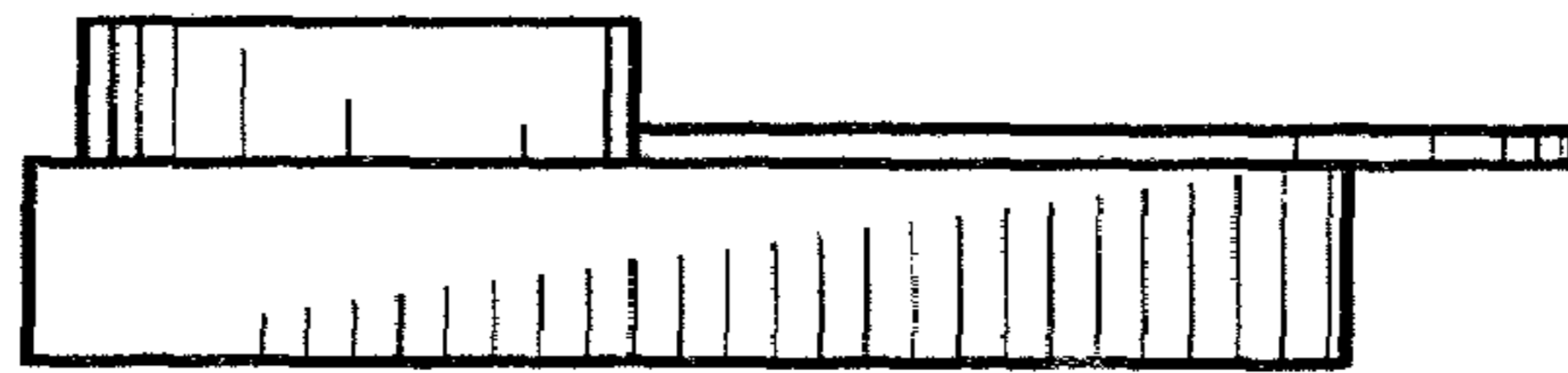

Fig. 5

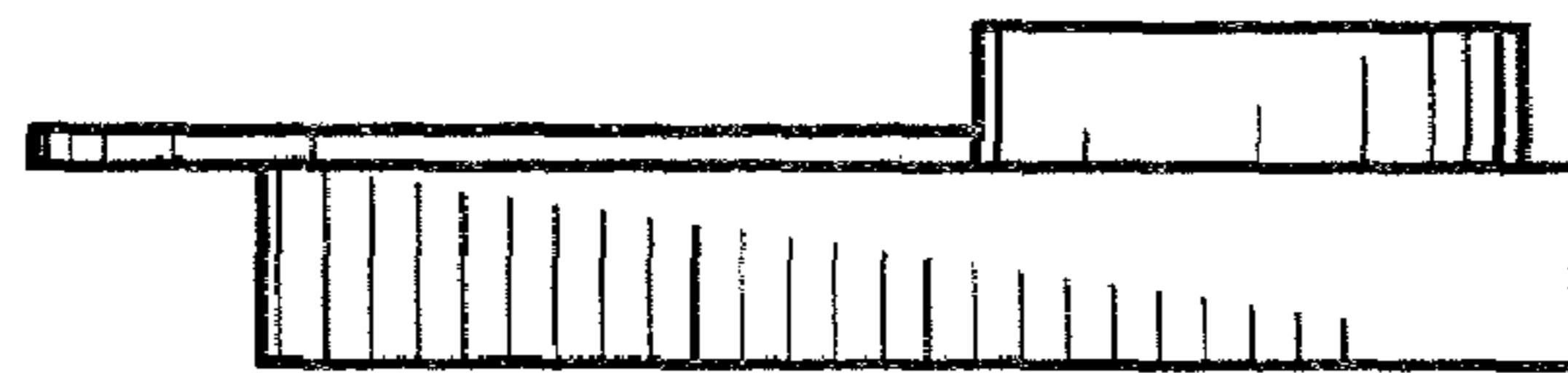

Fig. 6

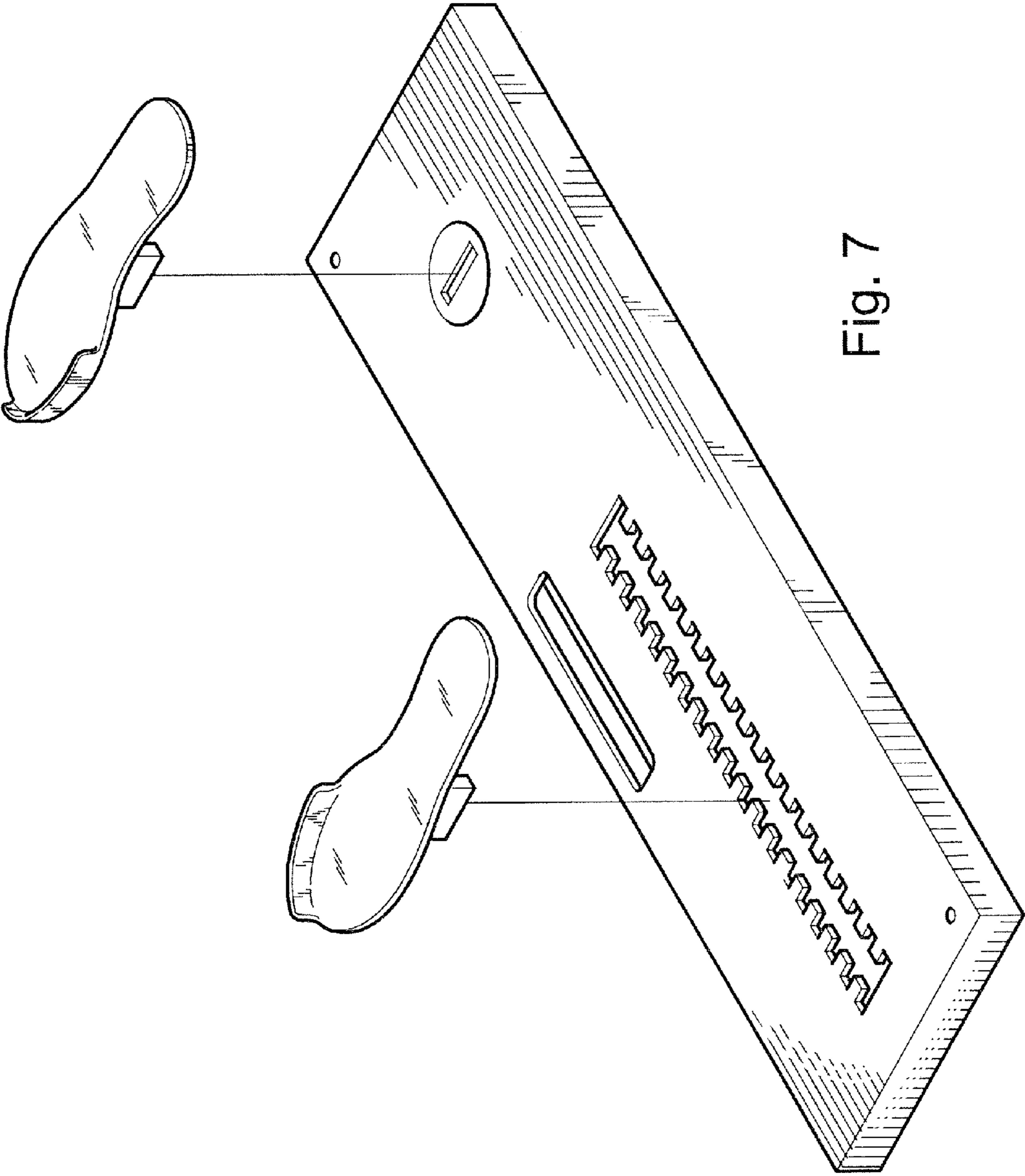

Fig. 7