



US00D602551S

(12) **United States Design Patent**  
**Oldknow**

(10) **Patent No.:** **US D602,551 S**

(45) **Date of Patent:** **\*\* Oct. 20, 2009**

(54) **GOLF CLUB HEAD**

(75) Inventor: **Andrew G. V. Oldknow**, Portland, OR  
(US)

(73) Assignee: **NIKE, Inc.**, Beaverton, OR (US)

(\*\*) Term: **14 Years**

(21) Appl. No.: **29/338,902**

(22) Filed: **Jun. 19, 2009**

(51) **LOC (9) Cl.** ..... **21-02**

(52) **U.S. Cl.** ..... **D21/759**

(58) **Field of Classification Search** ..... D21/733,  
D21/752, 759; 473/324-331, 343-346

See application file for complete search history.

(56) **References Cited**

U.S. PATENT DOCUMENTS

D354,325 S *	1/1995	Henwood	.....	D21/752
D414,234 S *	9/1999	Darrah	.....	D21/759
D461,862 S	8/2002	Madore et al.		
D499,158 S *	11/2004	Imamoto	.....	D21/752
D507,615 S *	7/2005	Imamoto	.....	D21/752
D508,544 S	8/2005	Madore		
D514,184 S	1/2006	Kawami		
D520,582 S	5/2006	Zelnicek		
D521,584 S	5/2006	Imamoto		
D532,469 S	11/2006	Oldknow		
D532,470 S	11/2006	Oldknow		
D532,471 S	11/2006	Oldknow		
D532,853 S	11/2006	Oldknow		
D532,854 S	11/2006	Oldknow		
D532,855 S	11/2006	Madore et al.		
D543,253 S	5/2007	Oldknow		
D543,600 S	5/2007	Oldknow		
D544,058 S	6/2007	Oldknow		
D544,557 S	6/2007	Oldknow		
D544,558 S	6/2007	Oldknow		
D544,559 S	6/2007	Oldknow		
D544,560 S	6/2007	Oldknow		
D544,561 S	6/2007	Oldknow		
D550,318 S	9/2007	Oldknow		
D550,799 S	9/2007	Lin		

D553,210 S *	10/2007	Harvell et al.	.....	D21/752
D553,211 S *	10/2007	Harvell et al.	.....	D21/752
D553,216 S *	10/2007	Harvell et al.	.....	D21/759
D553,217 S *	10/2007	Harvell et al.	.....	D21/759
D553,701 S	10/2007	Lin		

(Continued)

OTHER PUBLICATIONS

Edwin Watts Golf, Holiday 2004, p. 12, V-Steele Fairway Woods.  
Edwin Watts Golf, Summer 2003, p. 36, A0 Trimetal II Drivers & Fairway Woods.  
Austad's Golf, Spring 2008, pp. 6 and 8, B) King Cobra Speed LD 460 and Nike SQ Sumo 5900 Ti Drivers.  
Edwin Watts Golf, internet, Cleveland Launcher Fairway Woods 2009.

*Primary Examiner*—Mitchell I Siegel

(74) *Attorney, Agent, or Firm*—Banner & Witcoff, Ltd.

(57) **CLAIM**

The ornamental design for a golf club head, as shown and described.

**DESCRIPTION**

FIG. 1 is a perspective view of a golf club head showing my new design;

FIG. 2 is a bottom view thereof;

FIG. 3 is a rear view thereof;

FIG. 4 is a heel end view thereof;

FIG. 5 is a toe end view thereof;

FIG. 6 is a front view thereof; and,

FIG. 7 is a top view thereof.

The broken line segments at the distal inner-front corners of the shaded region forms an unclaimed boundary of the design. The broken line showing of the remainder of the golf club head is for environmental purposes only and forms no part of the claimed design.

**1 Claim, 4 Drawing Sheets**

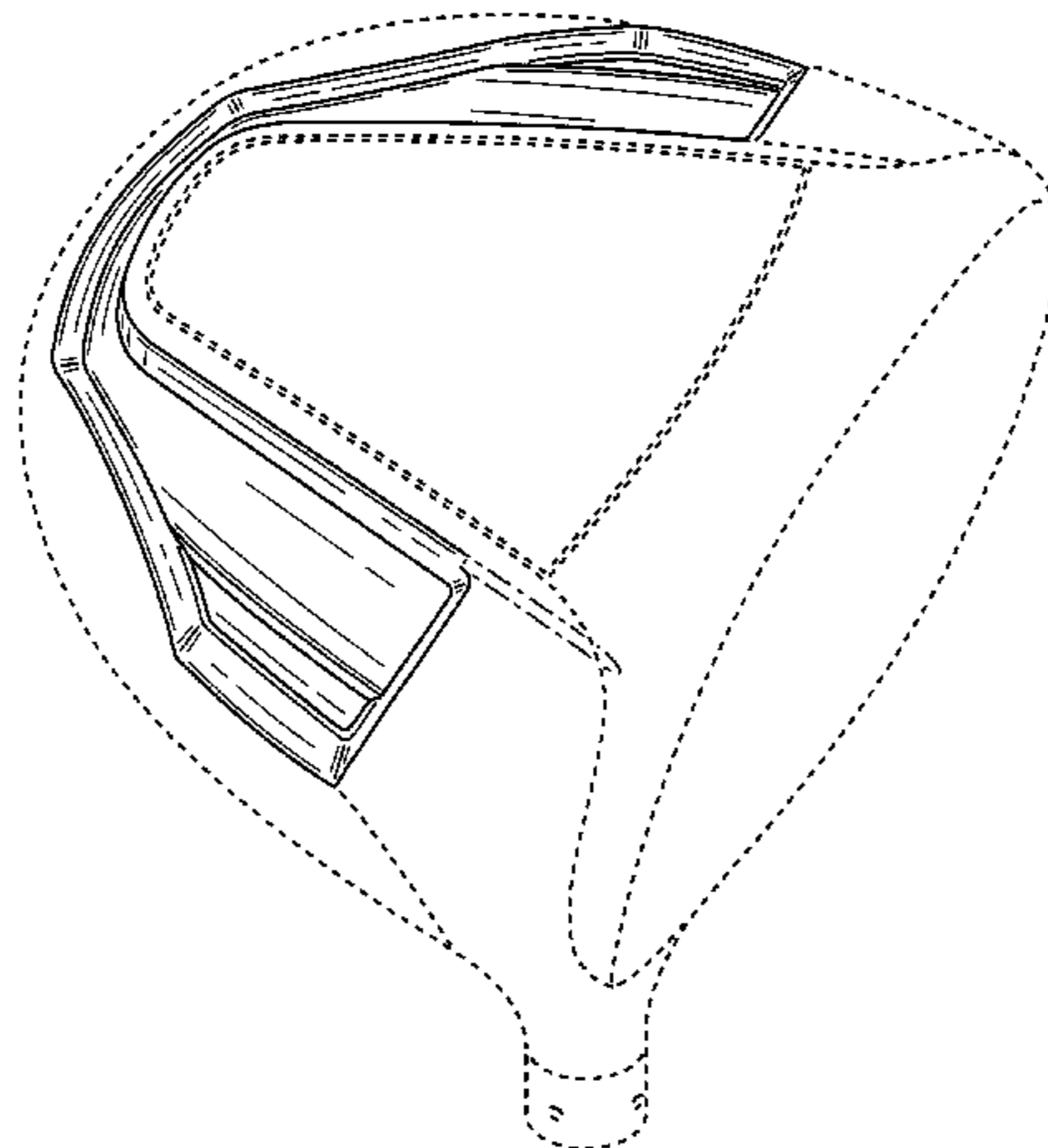

# US D602,551 S

Page 2

---

## U.S. PATENT DOCUMENTS

D577,400 S	*	9/2008	Oldknow et al. ....	D21/759	D577,785 S		9/2008	Oldknow et al.	
D577,401 S	*	9/2008	Oldknow et al. ....	D21/759	D577,786 S	*	9/2008	Oldknow et al. ....	D21/759
D577,402 S	*	9/2008	Oldknow et al. ....	D21/759	D577,787 S		9/2008	Oldknow et al.	
D577,403 S	*	9/2008	Oldknow et al. ....	D21/759	D577,788 S		9/2008	Oldknow et al.	
D577,404 S	*	9/2008	Oldknow et al. ....	D21/759	D585,101 S	*	1/2009	Glod .....	D21/752
D577,405 S		9/2008	Oldknow et al.		D588,223 S	*	3/2009	Kuan .....	D21/759
D577,406 S	*	9/2008	Oldknow et al. ....	D21/759	D591,812 S		5/2009	Breier et al.	
D577,784 S	*	9/2008	Oldknow et al. ....	D21/759	2009/0098948	A1	4/2009	Adams	

\* cited by examiner

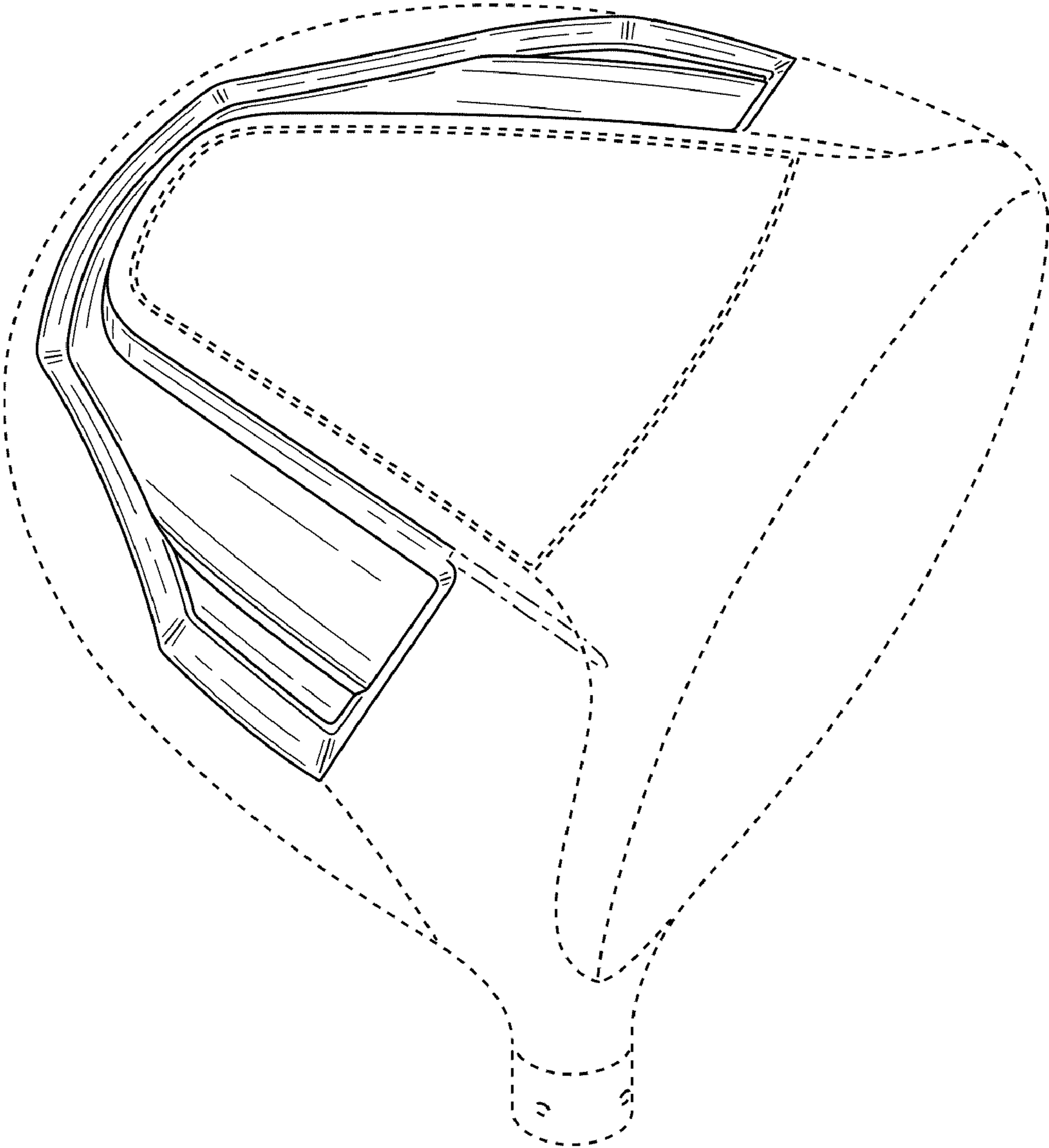

FIG. 1

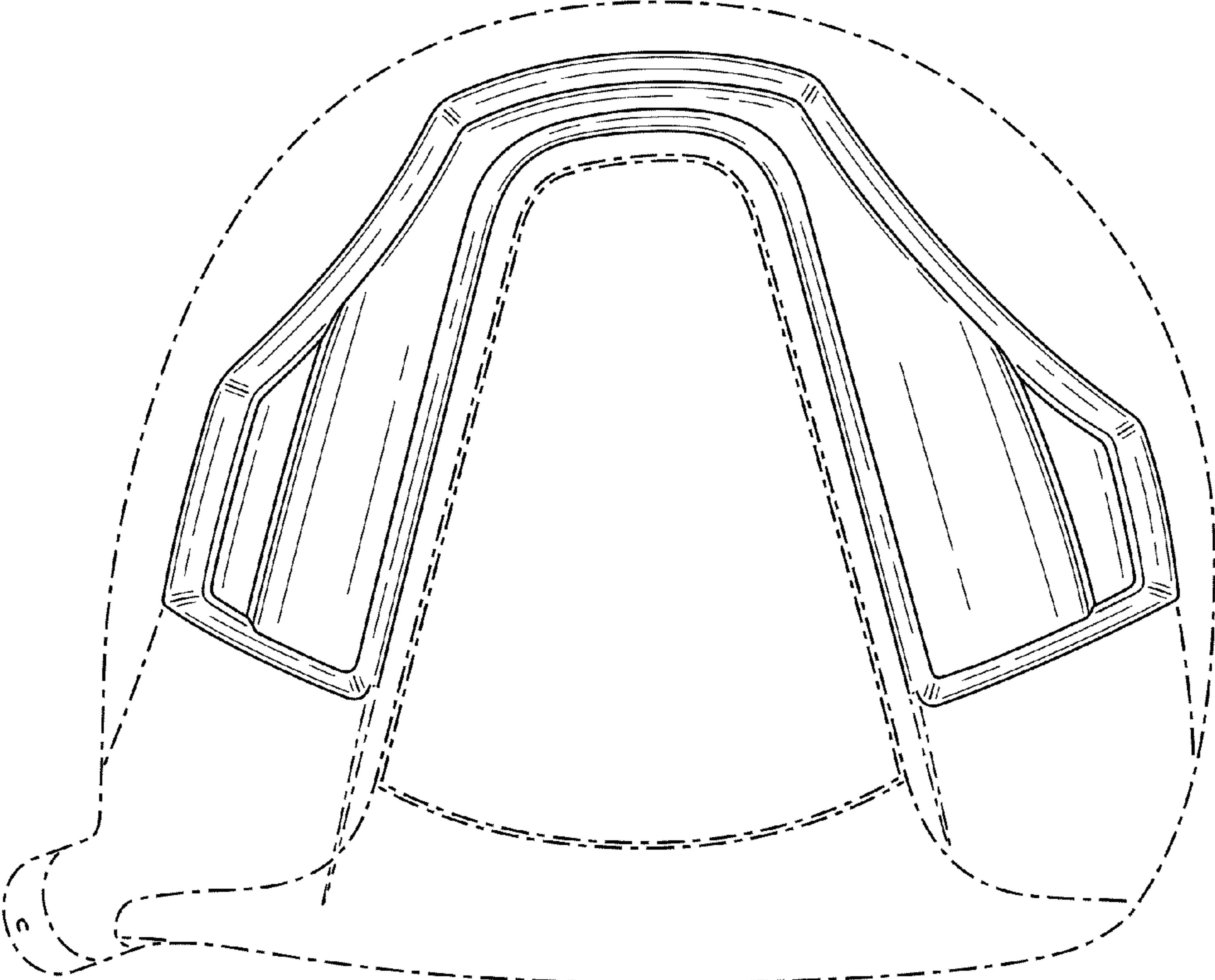

FIG. 2

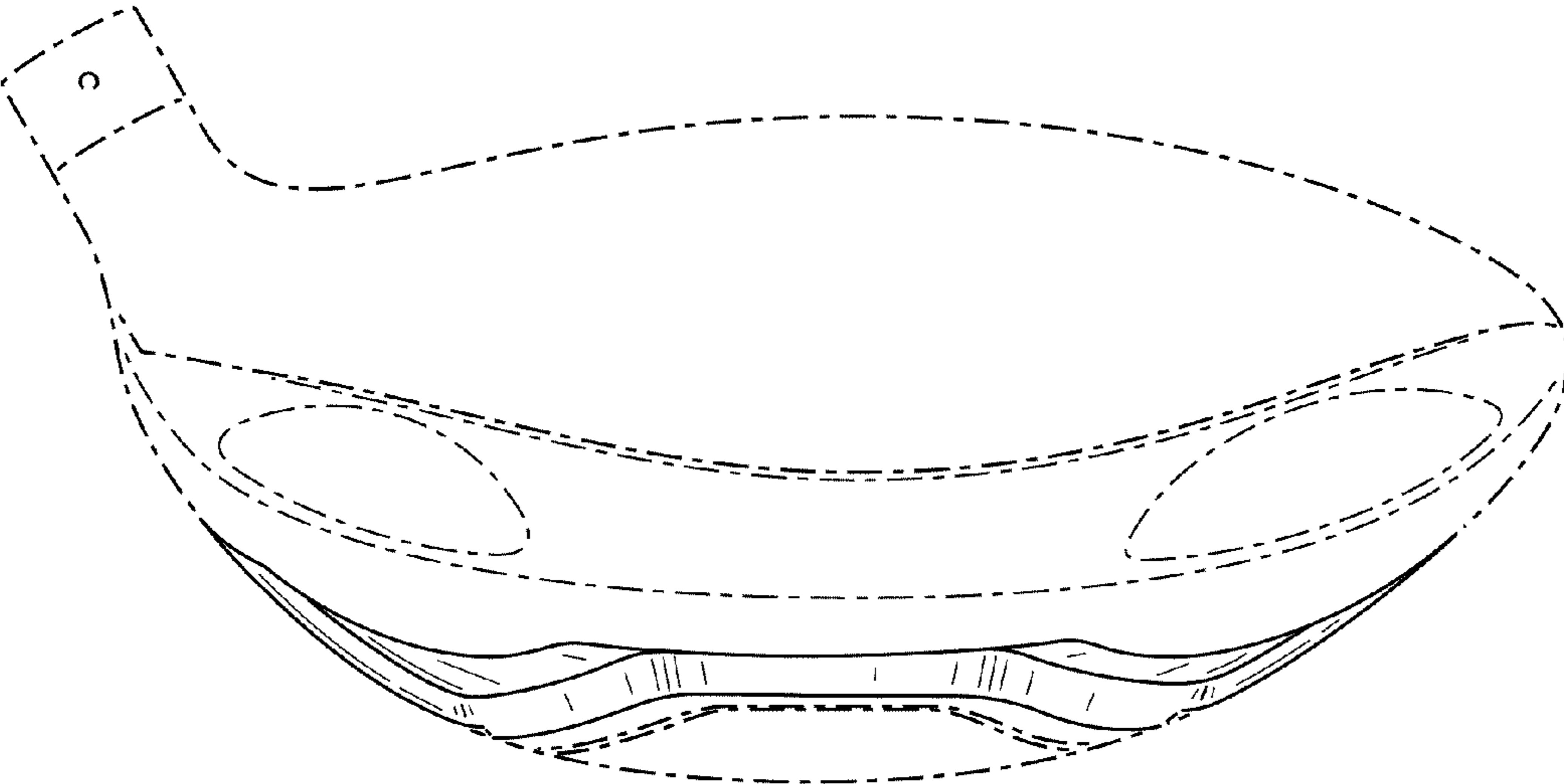

FIG. 3



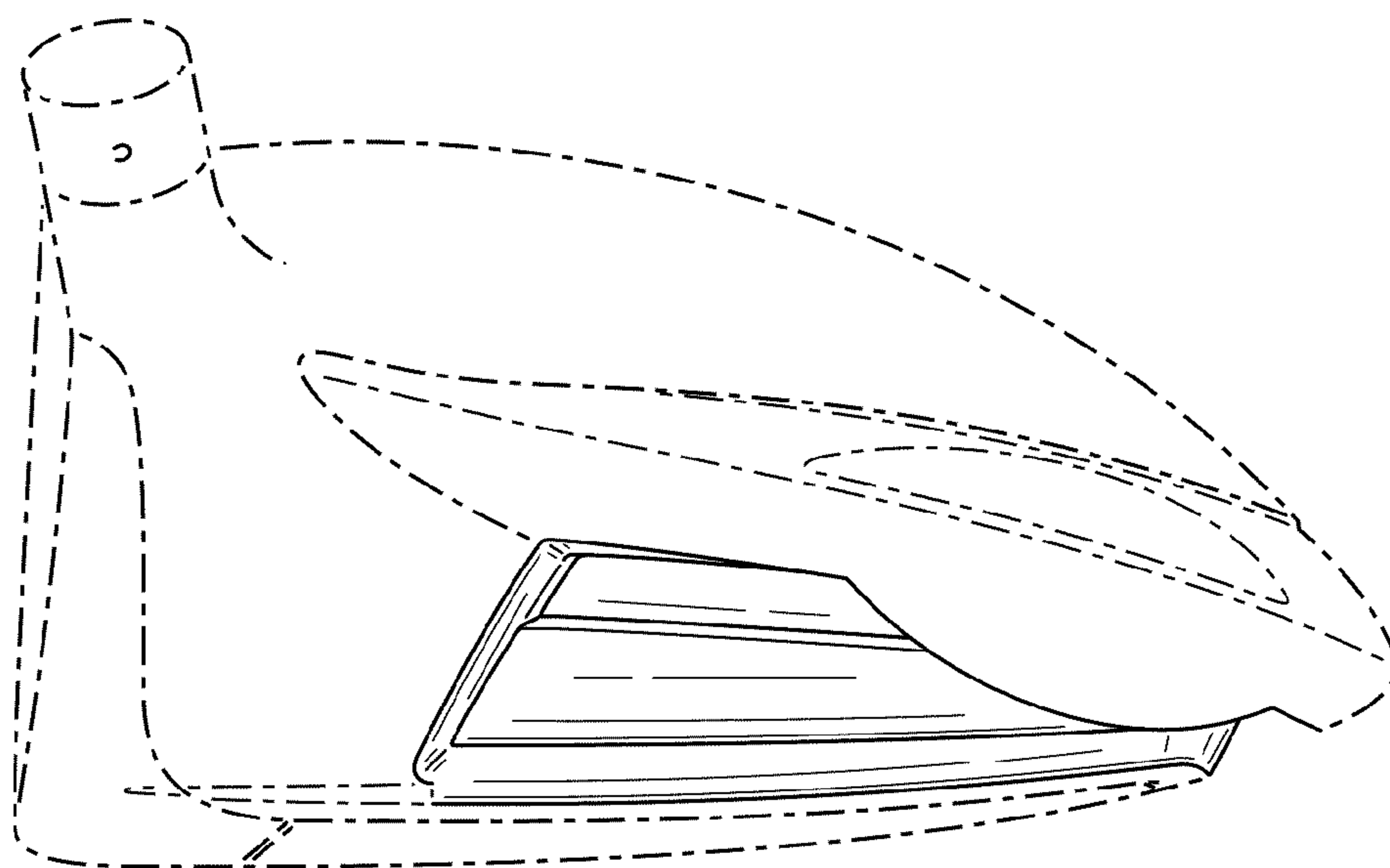

FIG. 4

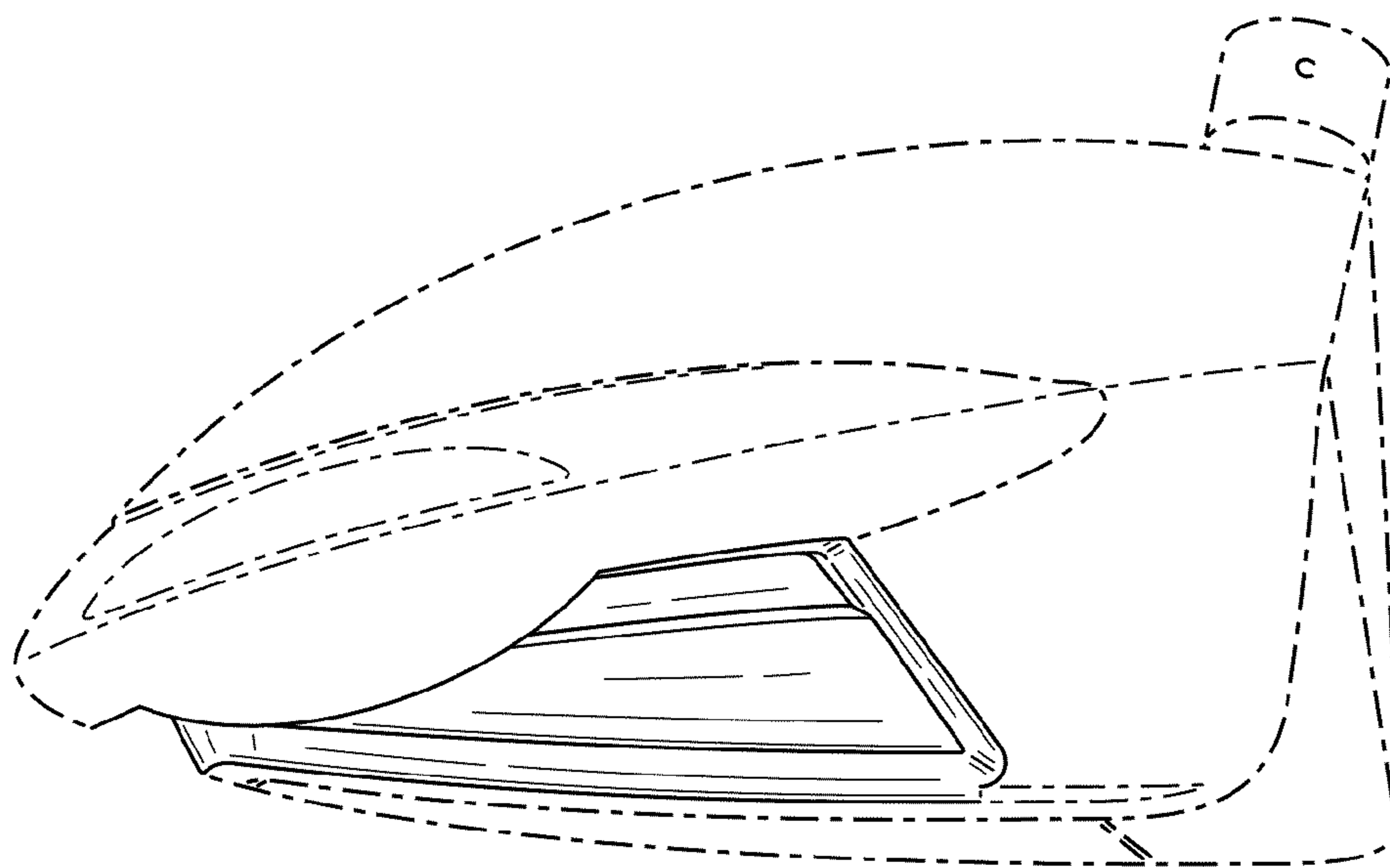

FIG. 5

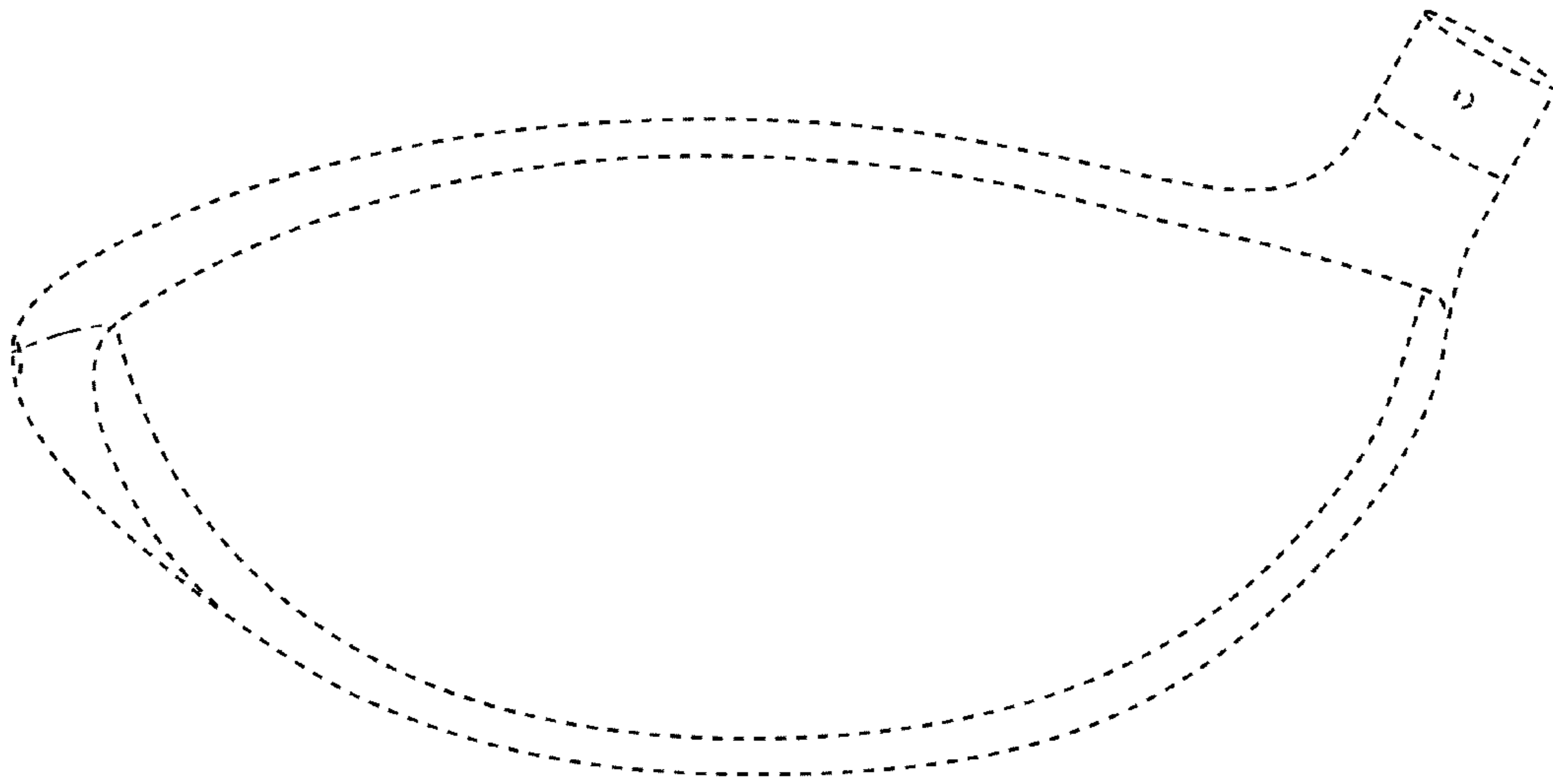

FIG. 6

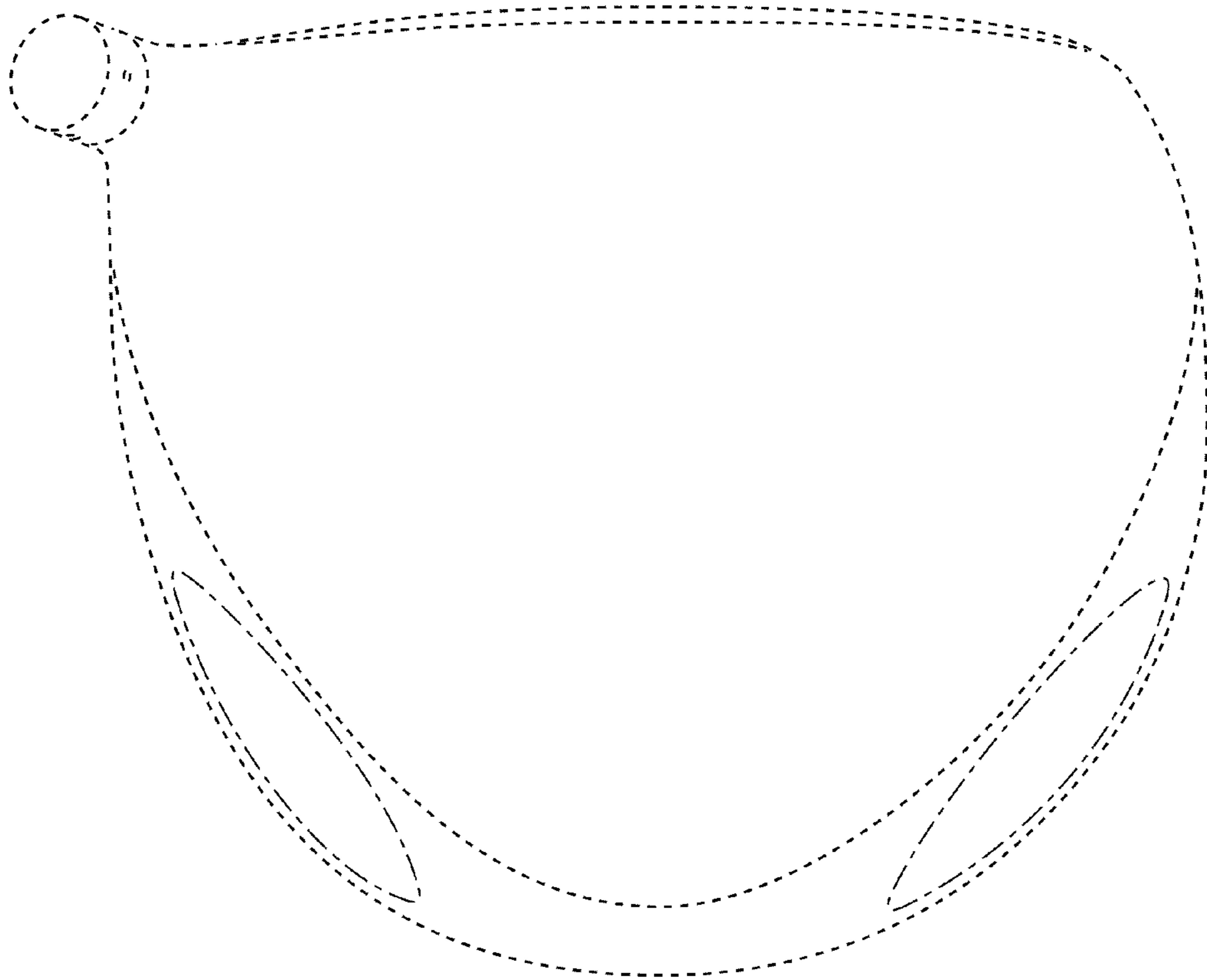

FIG. 7