



US00D602504S

(12) **United States Design Patent**  
**Lees**

(10) **Patent No.:** **US D602,504 S**  
(45) **Date of Patent:** **\*\* Oct. 20, 2009**

(54) **GANG MOWER**

**DESCRIPTION**

(76) **Inventor:** **Earl K. Lees**, 111Valley View Rd. Ext.,  
Harrisville, PA (US) 16038

(\*\*) **Term:** **14 Years**

(21) **Appl. No.:** **29/301,445**

(22) **Filed:** **Feb. 29, 2008**

(51) **LOC (9) Cl.** ..... **15-03**

(52) **U.S. Cl.** ..... **D15/28; D15/16**

(58) **Field of Classification Search** ..... **D15/10,**  
**D15/16, 17, 27, 28; 56/6, 7, 13.7, 15.9, 13.6**  
See application file for complete search history.

(56) **References Cited**

**U.S. PATENT DOCUMENTS**

1,818,487	A *	8/1931	Lontz	.....	56/7
2,153,876	A *	4/1939	Roseman	.....	56/7
3,832,835	A *	9/1974	Hall et al.	.....	56/7
4,161,858	A *	7/1979	Gerrits	.....	56/7
4,306,402	A *	12/1981	Whimp	.....	56/7
4,330,981	A *	5/1982	Hall et al.	.....	56/7
4,478,026	A *	10/1984	Mullet et al.	.....	56/7

(Continued)

*Primary Examiner*—Stella M Reid

*Assistant Examiner*—Mark A Goodwin

(74) *Attorney, Agent, or Firm*—Harry I. Leon; Vivian L. Steadman

(57) **CLAIM**

The ornamental design for a gang mower, as shown and described.

FIG. 1 is a left side perspective view of a gang mower showing my new design;

FIG. 2 is a right side perspective view thereof;

FIG. 3 is a front view thereof;

FIG. 4 is an enlarged front perspective view of a fragmentary portion thereof taken left of center along line 4—4 of FIG. 3;

FIG. 5 is an enlarged front perspective view of a fragmentary portion thereof taken on the left end along line 5—5 of FIG. 3;

FIG. 6 is an enlarged front perspective view of a fragmentary portion thereof taken right of center along line 6—6 of FIG. 3;

FIG. 7 is an enlarged right rear perspective view of a fragmentary portion thereof, the arrow on the right side of line 10—10 lying in approximately the same imaginary vertical plane as does the arrow on the left side of line 6—6 shown in FIG. 3., a control box and its electrical connections being shown in broken lines which form no part of the claimed design;

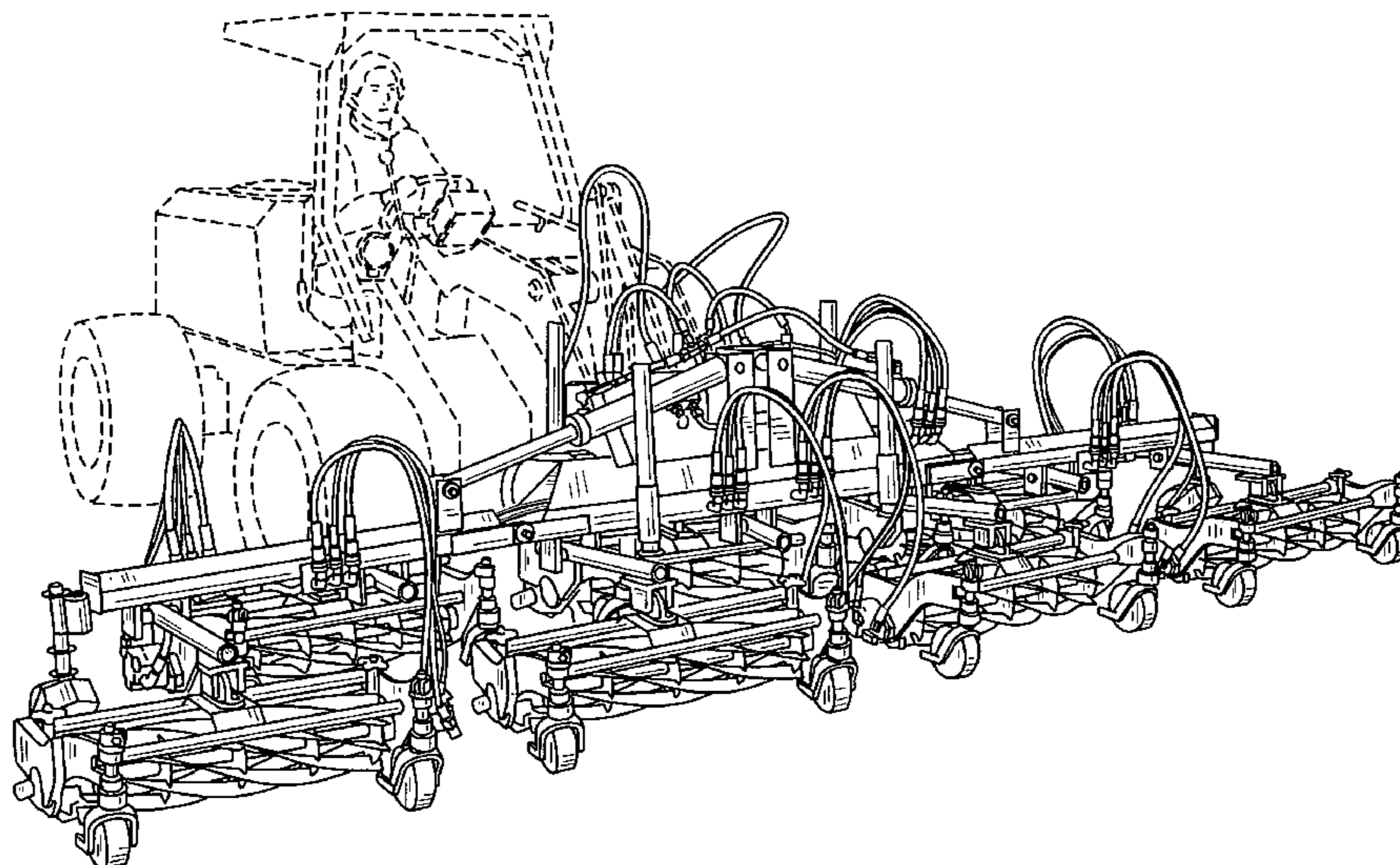
FIG. 8 is a right side perspective view thereof, when the gang mower is disposed in its folded position;

FIG. 9 is a front view thereof, when the gang mower is disposed in its folded position; and,

FIG. 10 is an enlarged right side rear perspective view of a fragmentary portion thereof taken left of center along line 10—10 of FIG. 7, the control box being shown in broken lines and forming no part of the invention.

The broken line showing of the tractor and portions of the tractor in FIGS. 1—4, and 8—10, and the control box in FIGS. 7 and 10 is included for the purpose of illustrating environmental structure and forms no part of the claimed design.

**1 Claim, 10 Drawing Sheets**



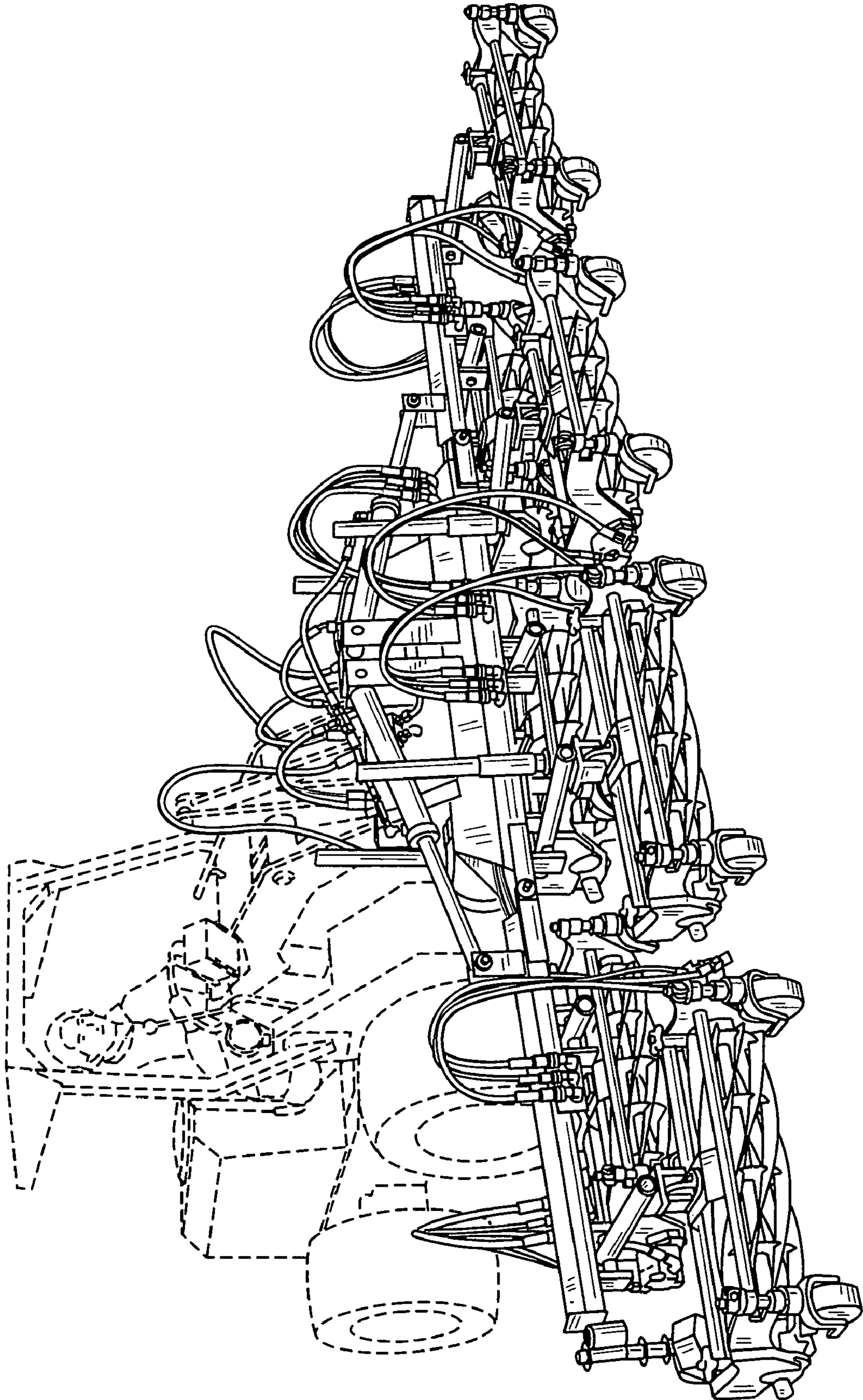
# US D602,504 S

Page 2

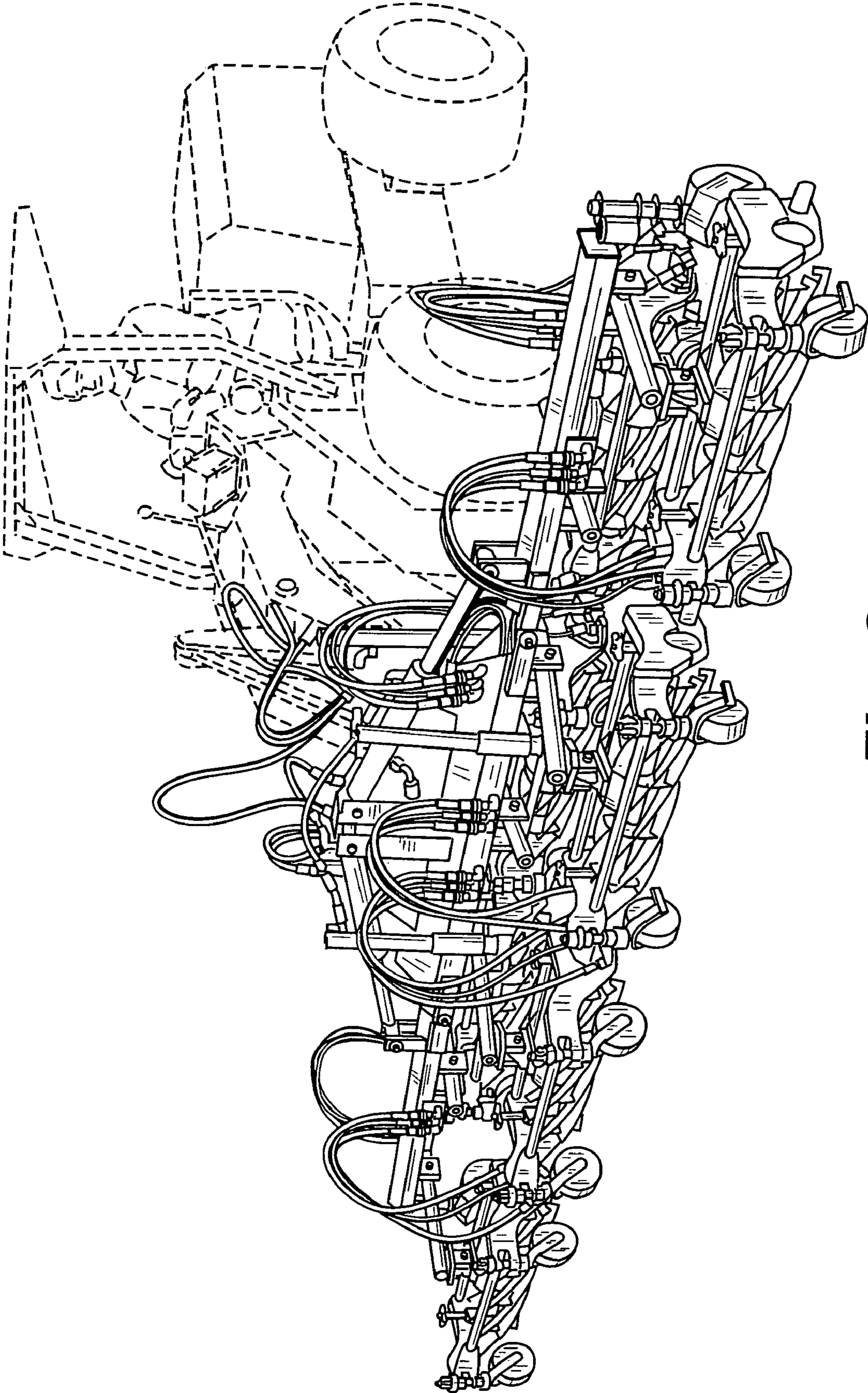
## U.S. PATENT DOCUMENTS

4,570,425	A *	2/1986	Carr	56/7	6,412,258	B1 *	7/2002	Doerflinger	56/7
5,042,236	A *	8/1991	Lamusga et al.	56/7	6,481,191	B1 *	11/2002	Short	56/7
5,069,022	A *	12/1991	Vandermark	56/6	6,530,198	B2 *	3/2003	Bergsten et al.	56/10.4
5,261,213	A *	11/1993	Humphrey	56/2	D477,330	S *	7/2003	Klein et al.	D15/13
5,497,603	A *	3/1996	Short	56/7	6,698,171	B2 *	3/2004	Doerflinger	56/7
5,497,604	A *	3/1996	Lonn	56/10.2 H	2002/0184865	A1 *	12/2002	Short	56/7
5,623,817	A *	4/1997	Bricko et al.	56/7	2002/0184866	A1 *	12/2002	Doerflinger	56/7
D395,900	S *	7/1998	Shannon et al.	D15/28	2004/0055266	A1 *	3/2004	Reimers et al.	56/7
5,865,017	A *	2/1999	Short	56/7	2004/0148917	A1 *	8/2004	Eastwood	56/6
6,058,687	A *	5/2000	Short	56/7	2005/0188665	A1 *	9/2005	Reimers et al.	56/14.7
6,131,378	A *	10/2000	Lees	56/7	2006/0201124	A1 *	9/2006	Hall et al.	56/16.7
6,351,929	B1 *	3/2002	Gust et al.	56/7	2007/0204581	A1 *	9/2007	Reimers et al.	56/7

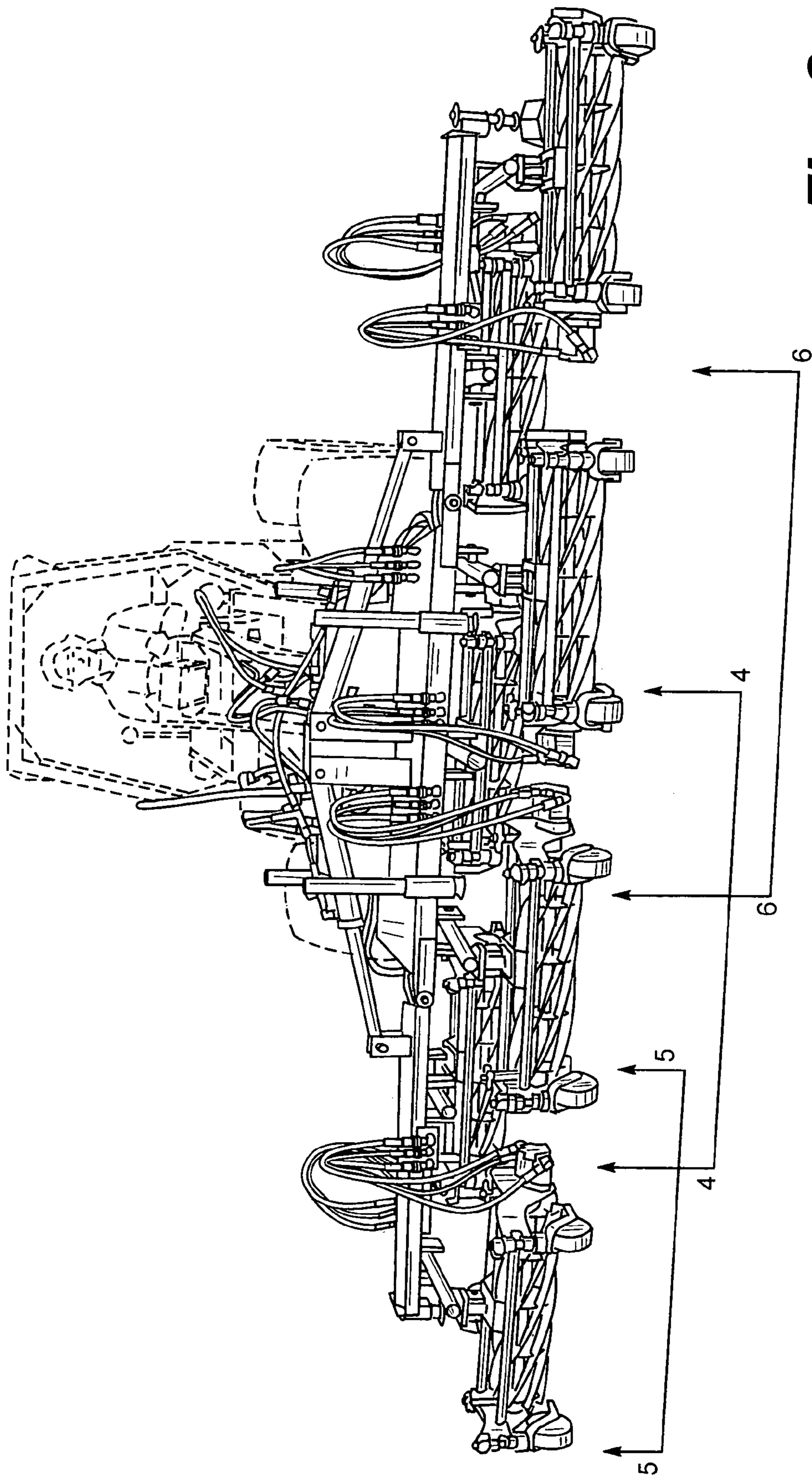
\* cited by examiner



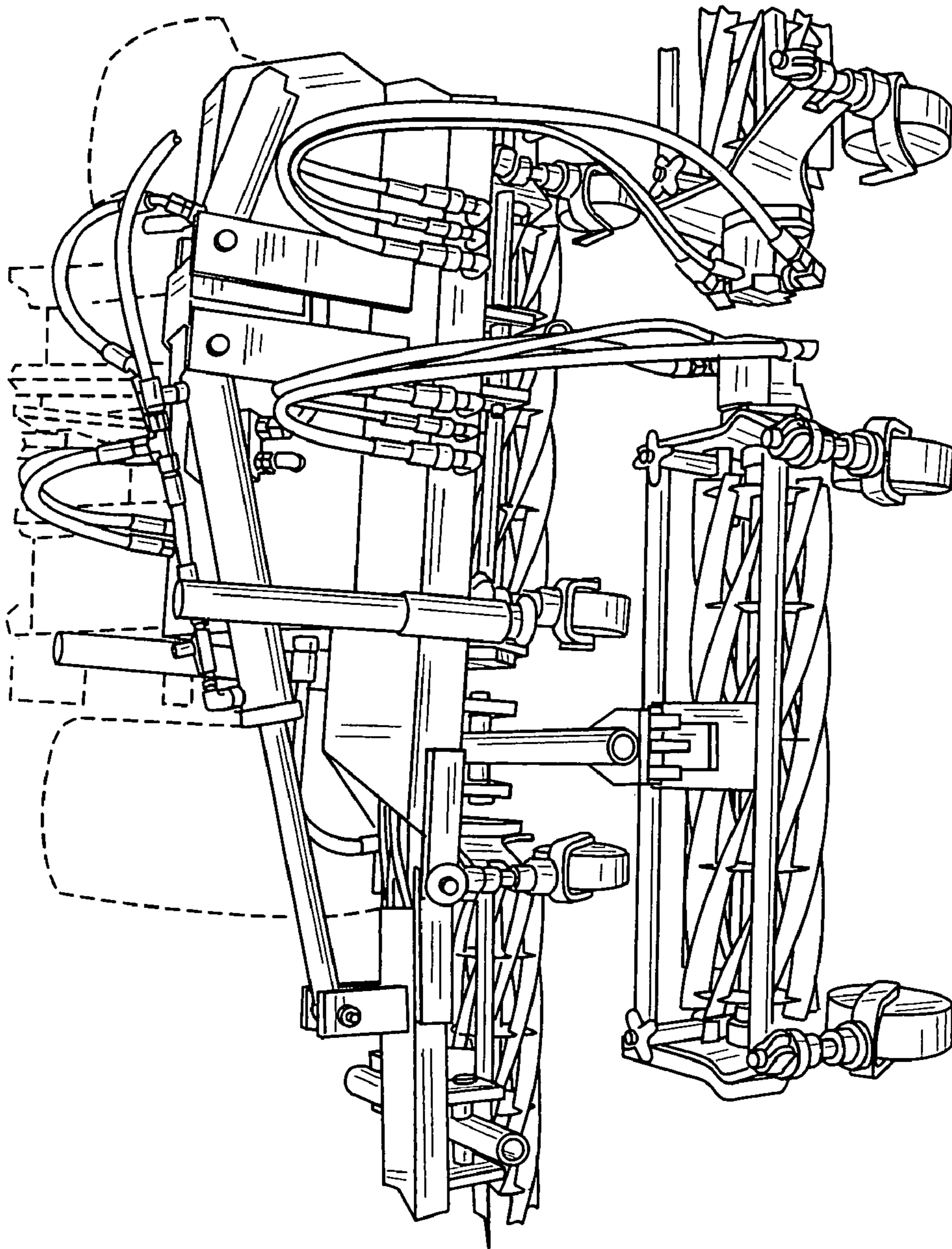
**Fig. 1**



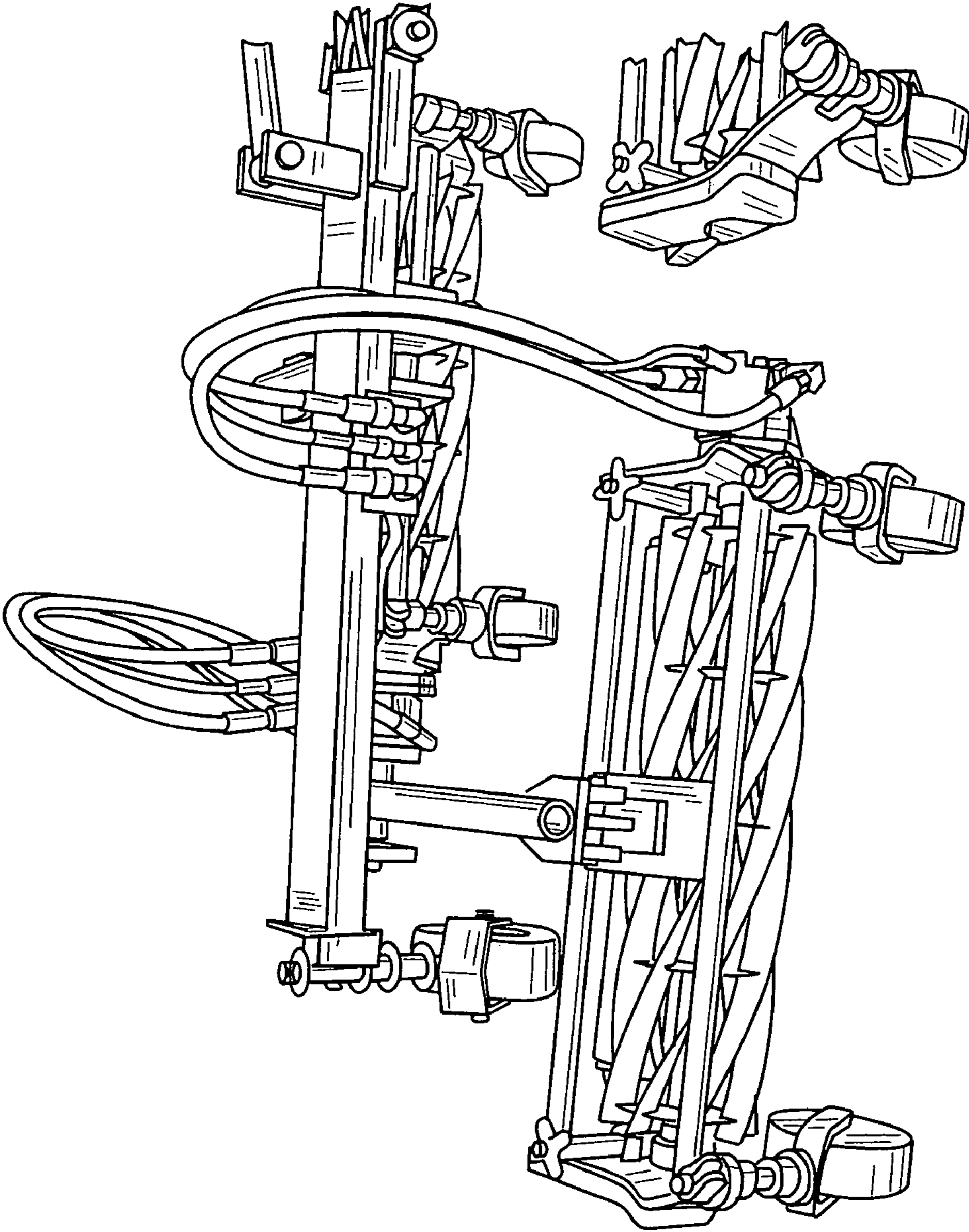
**Fig. 2**



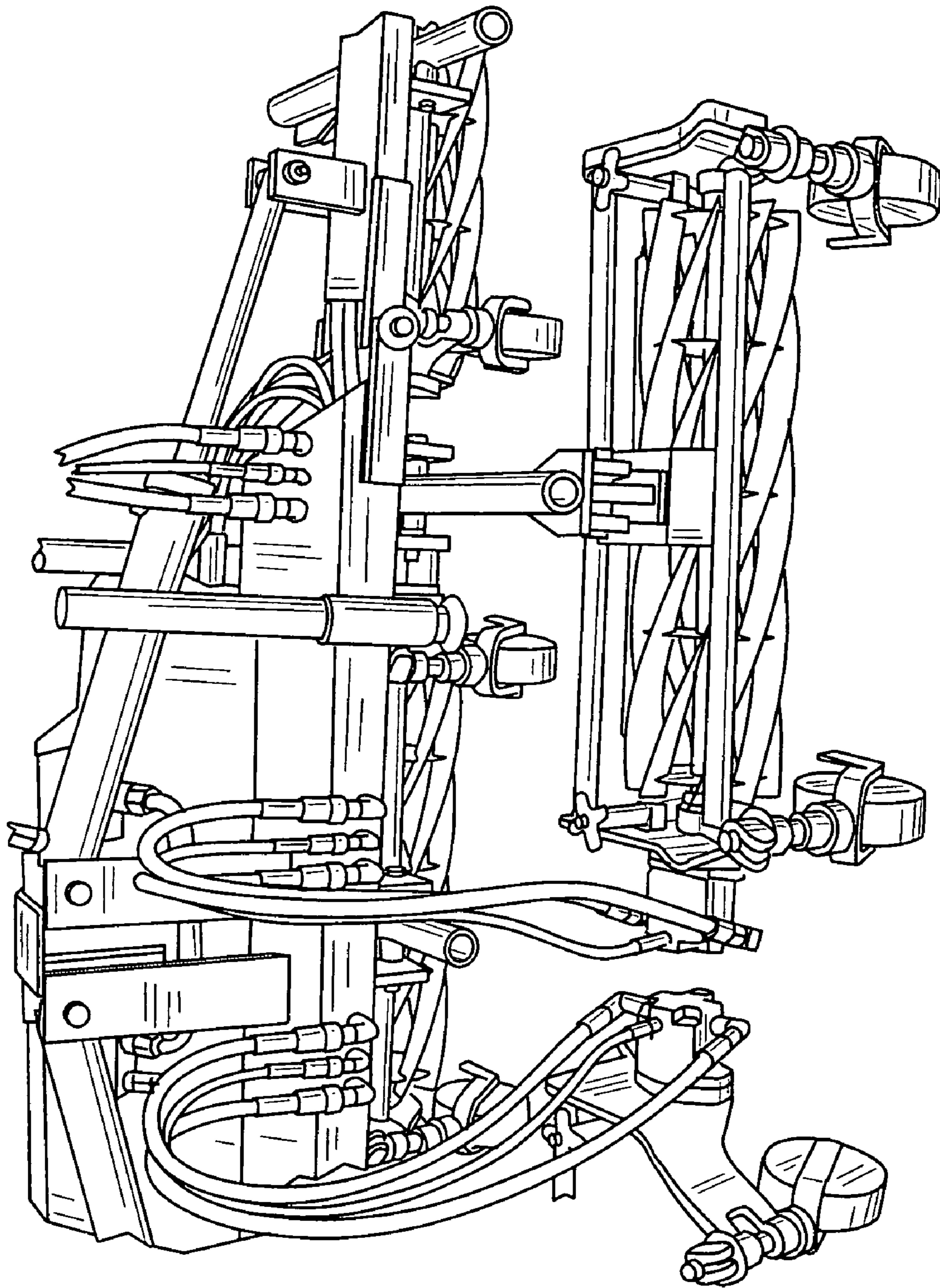
**Fig. 3**



**Fig. 4**

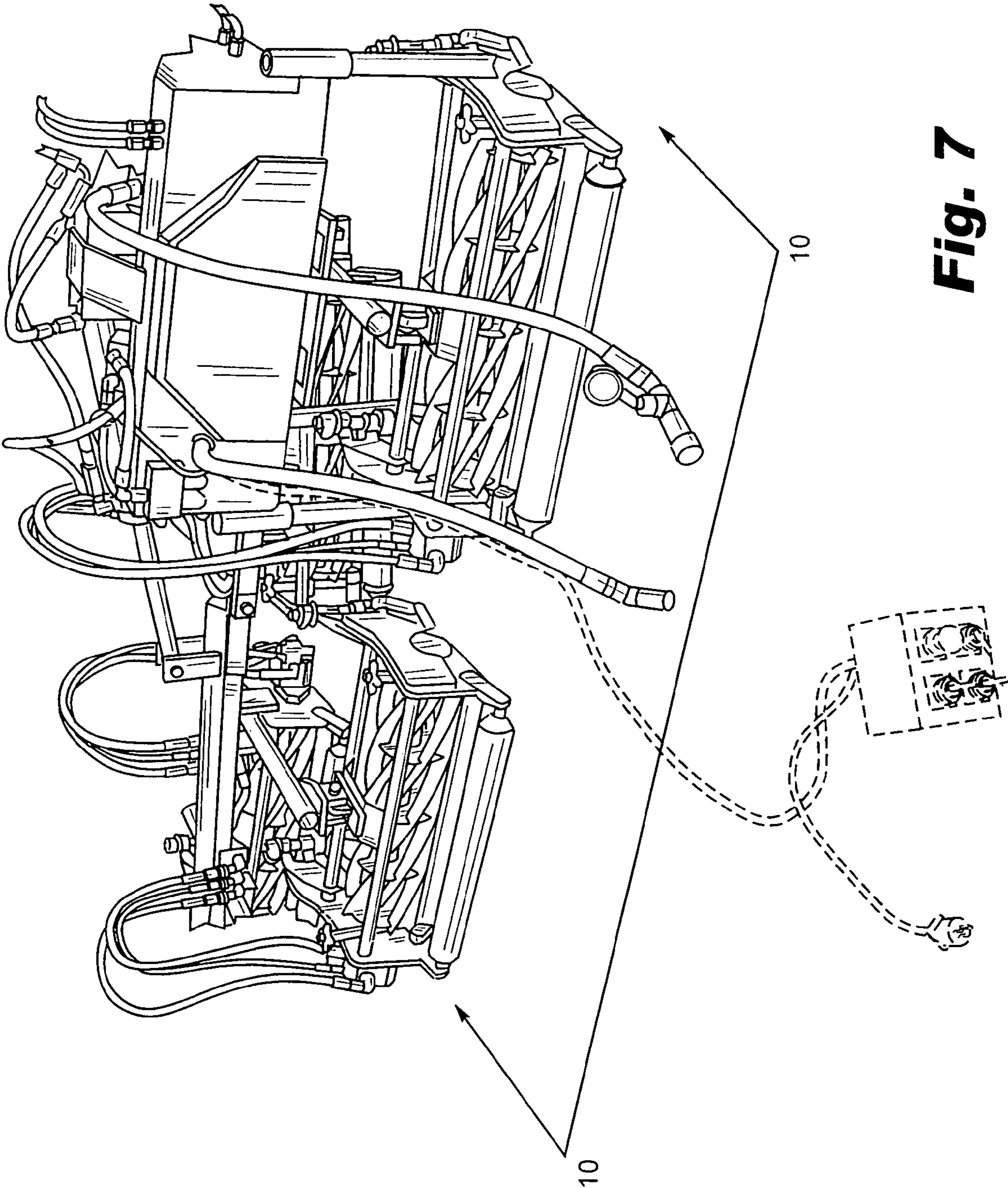


**Fig. 5**



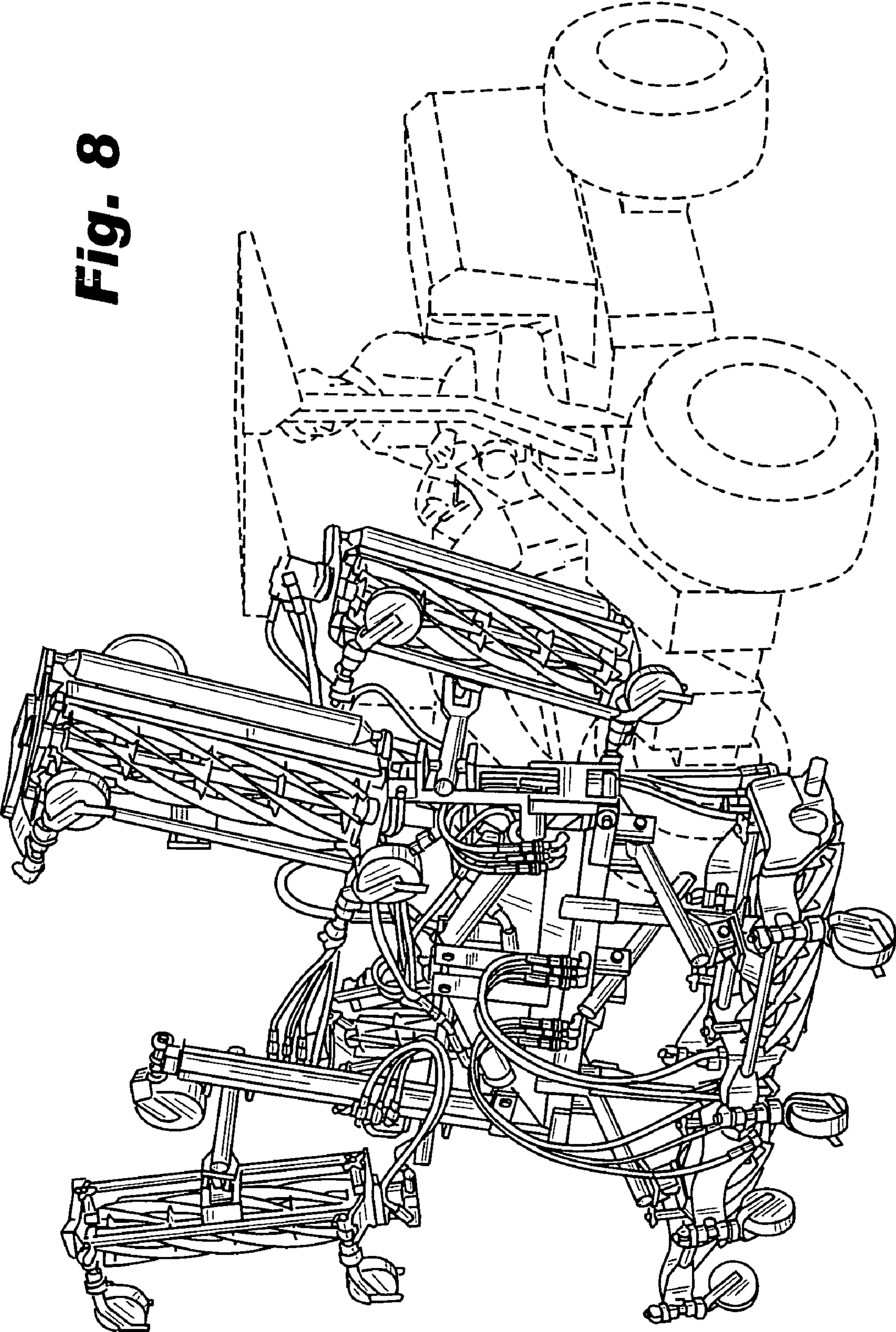
**Fig. 6**

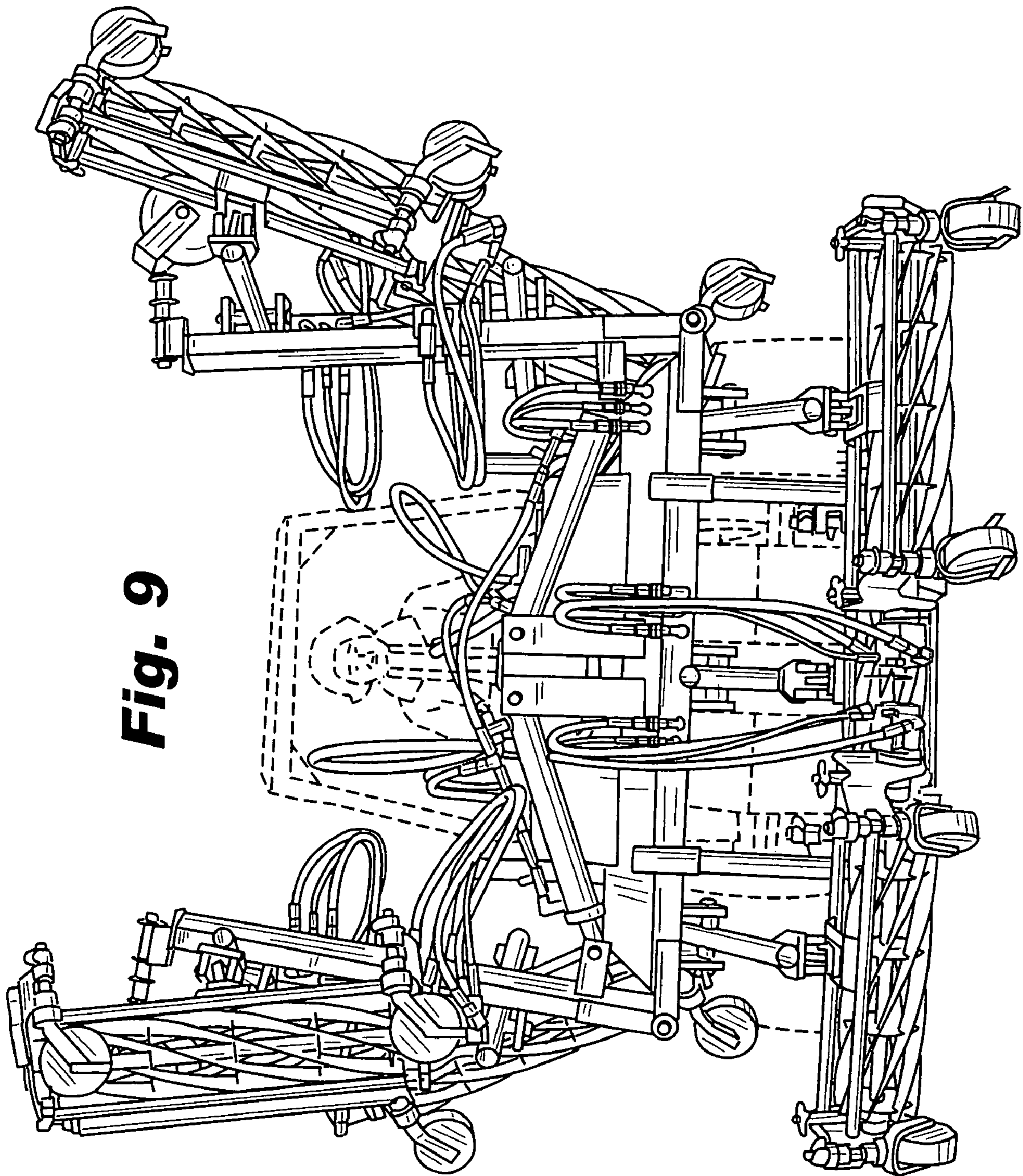




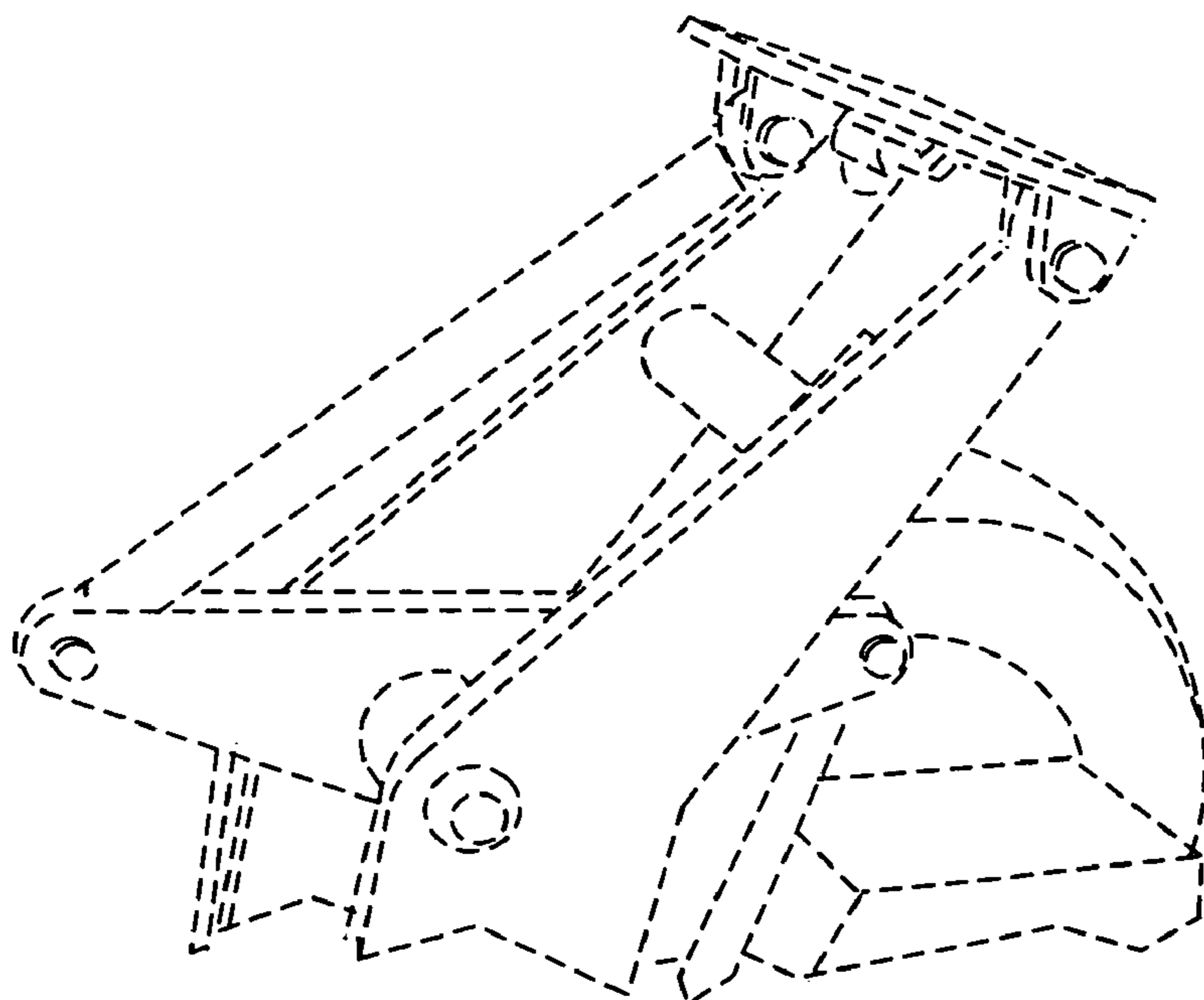
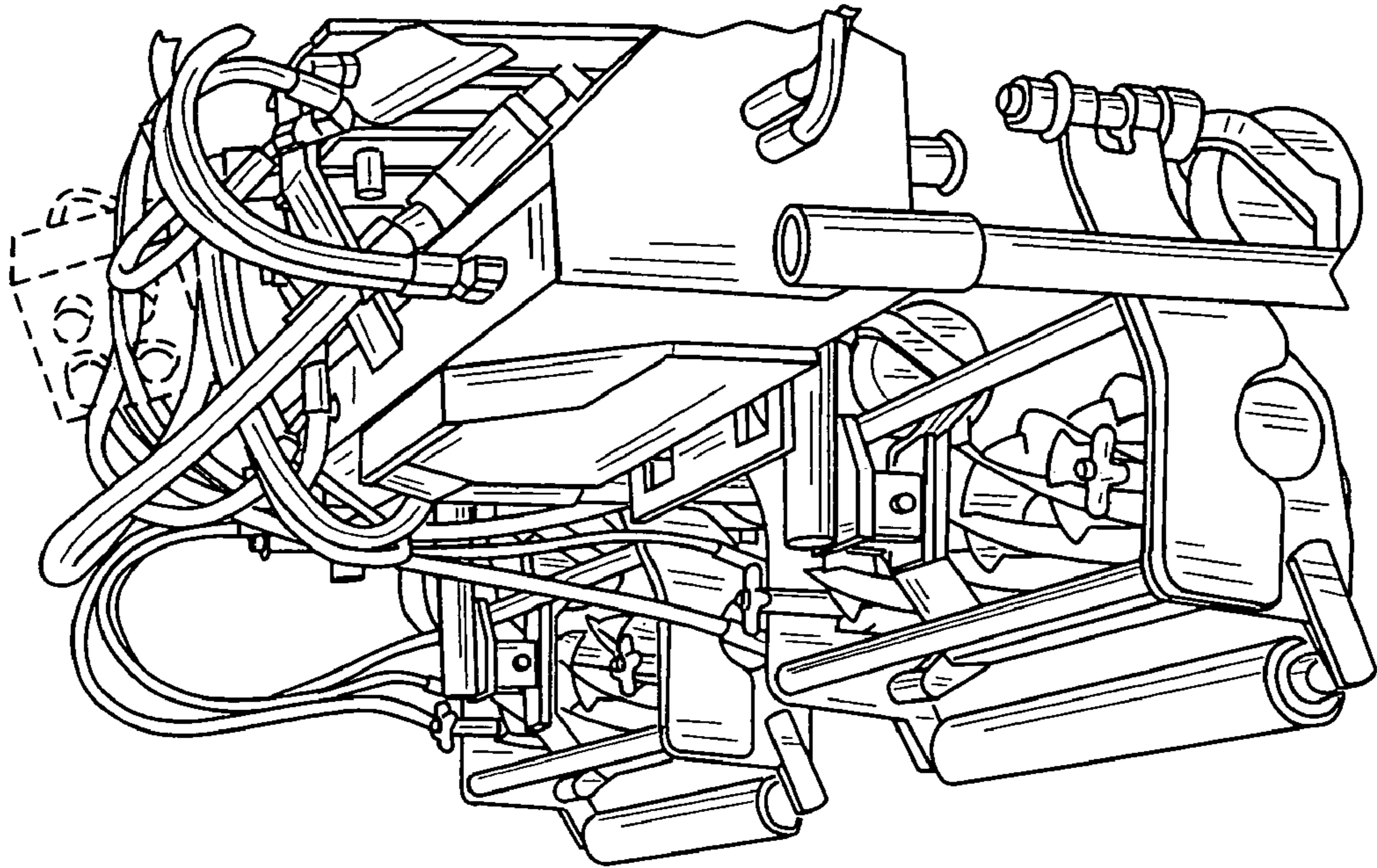
**Fig. 7**

**Fig. 8**





**Fig. 9**



**Fig. 10**