



(12) **United States Design Patent**
Killo et al.

(10) **Patent No.:** **US D602,388 S**
(45) **Date of Patent:** **** Oct. 20, 2009**

(54) **WIRELESS SENSOR**
(75) Inventors: **Jason C. Killo**, Emmaus, PA (US);
Nikhil Vithal Bhate, East Norriton, PA
(US); **Greg Edward Sloan**, Allentown,
PA (US); **Gregory Altonen**, Easton, PA
(US); **Elliot G. Jacoby**, Glenside, PA
(US)
(73) Assignee: **Lutron Electronics Co., Inc.**,
Coopersburg, PA (US)
(**) Term: **14 Years**
(21) Appl. No.: **29/336,292**
(22) Filed: **Apr. 30, 2009**
(51) **LOC (9) Cl.** **10-05**
(52) **U.S. Cl.** **D10/106; D10/46; D10/104**
(58) **Field of Classification Search** **D10/46,**
D10/81, 104-106; 307/112, 116, 117, 125,
307/139, 140, 32; 340/825.3, 825.31, 825.32,
340/825.34, 825.36, 506, 508, 517, 539,
340/541, 565, 587, 521, 522, 567; 700/11,
700/14, 22, 28, 275; 315/119, 149-159,
315/360, 362, 120, 291, 224, 307, 142, 292;
362/1, 4, 5

See application file for complete search history.
(56) **References Cited**

U.S. PATENT DOCUMENTS
D308,647 S 6/1990 Mayo
(Continued)
OTHER PUBLICATIONS
Lutron Electronics Co., Inc., MW-PS-WH microPS Daylight Sensor
Specification Submittal Sheet, Apr. 1, 2004, 4 sheets.
(Continued)
Primary Examiner—Antoine D Davis
(74) *Attorney, Agent, or Firm*—Mark E. Rose; Philip N.
Smith; Bridget L. McDonough

(57) **CLAIM**
We claim the ornamental design for a wireless sensor, as
shown and described.

DESCRIPTION

FIG. 1 is a perspective view of a wireless sensor according to
a first embodiment of our new design.
FIG. 2 is a front view thereof.
FIG. 3 is a left side view thereof.

FIG. 4 is a right side view thereof.
FIG. 5 is a top view thereof.
FIG. 6 is a bottom view thereof.
FIG. 7 is a perspective view of a wireless sensor according to
a second embodiment of our new design.
FIG. 8 is a front view thereof, the left side, right side, top, and
bottom views, respectively, of the second embodiment being
identical to the left side, right side, top, and bottom views of
the first embodiment.
FIG. 9 is a perspective view of a wireless sensor according to
a third embodiment of our new design.
FIG. 10 is a front view thereof.
FIG. 11 is a left side view thereof.
FIG. 12 is a right side view thereof.
FIG. 13 is a top view thereof.
FIG. 14 is a bottom view thereof.
FIG. 15 is a perspective view of a wireless sensor according to
a fourth embodiment of our new design.
FIG. 16 is a front view thereof, the left side, right side, top, and
bottom views, respectively, of the fourth embodiment being
identical to the left side, right side, top, and bottom views of
the third embodiment.
FIG. 17 is a perspective view of a wireless sensor according to
a fifth embodiment of our new design.
FIG. 18 is a front view thereof.
FIG. 19 is a left side view thereof.
FIG. 20 is a right side view thereof.
FIG. 21 is a top view thereof.
FIG. 22 is a bottom view thereof.
FIG. 23 is a perspective view of a wireless sensor according to
a sixth embodiment of our new design.
FIG. 24 is a front view thereof.
FIG. 25 is a left side view thereof.
FIG. 26 is a right side view thereof.
FIG. 27 is a top view thereof; and,
FIG. 28 is a bottom view thereof.
The rear views form no part of the design and are omitted.

1 Claim, 14 Drawing Sheets

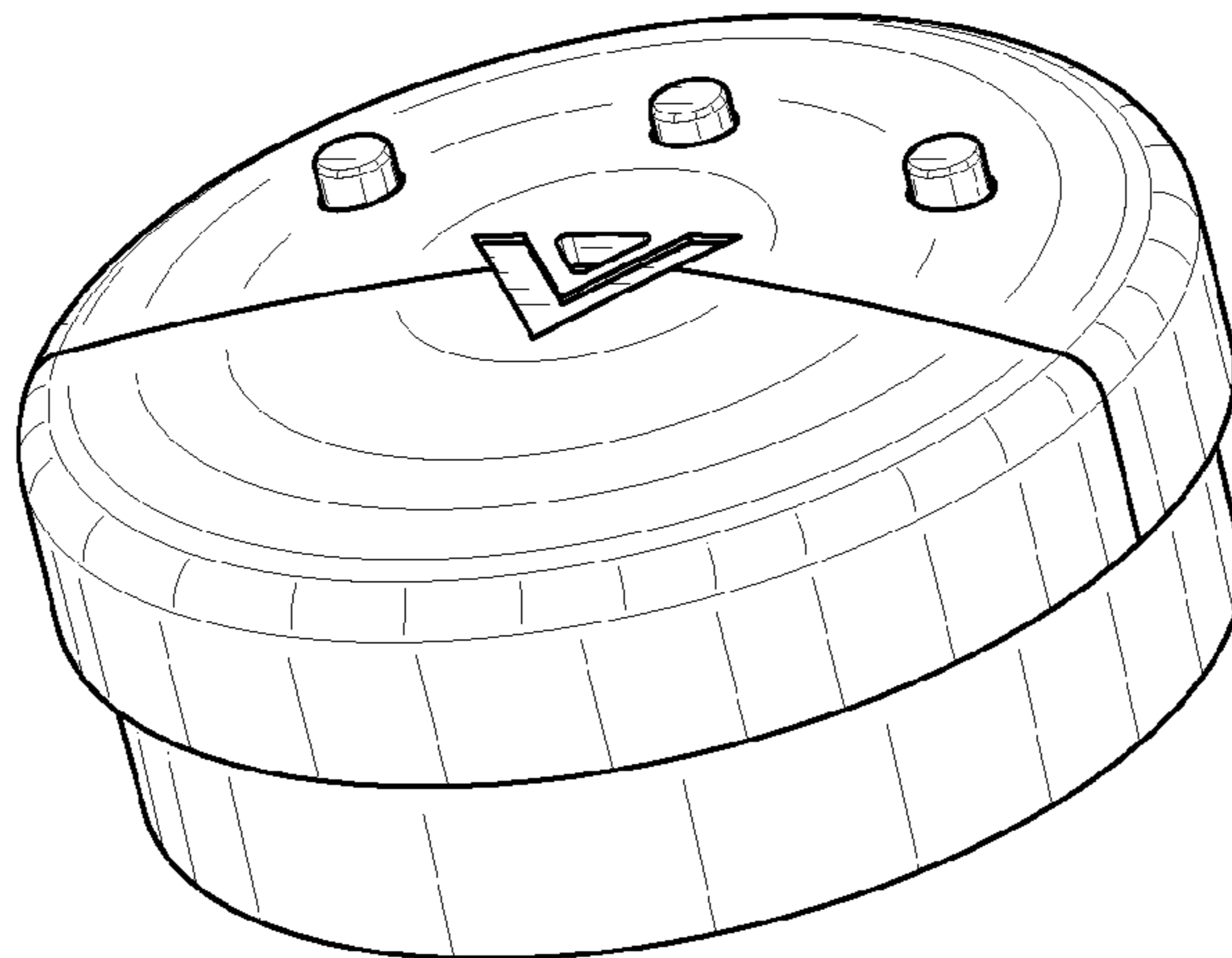

US D602,388 S

Page 2

U.S. PATENT DOCUMENTS

D360,842 S 8/1995 Hu
D369,348 S 4/1996 Hu
D397,233 S * 8/1998 Bassford D10/104
D402,269 S 12/1998 Waters
D451,386 S 12/2001 Rice
D454,337 S 3/2002 Robinson
6,388,399 B1 5/2002 Eckel et al.
D494,235 S 8/2004 Edwards
D516,043 S 2/2006 Jacoby et al.
D597,430 S * 8/2009 Sloan et al. D10/106

OTHER PUBLICATIONS

Lutron Electronics Co., Inc., Ecosystem C-SR-M1-WH Fixture Mountable Daylight Sensor Specification Submittal Sheet, Feb. 19, 2008, 3 sheets.

The Watt Stopper, LS-290C v2 Photocell Installation Instructions, Jul. 2007, 2 sheets.

Leviton Manufacturing Co., Inc., Centura Fluorescent Dimming & Energy Management System Brochure, 2001, 12 pages.

Sensor Switch, Inc., CM-PC On/Off Photocell Sensor Data Sheet, Jul. 10, 2006, 2 sheets.

PLC Multipoint, Inc., MAS Milli-Amp Light Sensor Data Sheet, Feb. 22, 2008, 2 sheets.

U.S. Appl. No. 29/322,082, filed Jul. 29, 2008, Sloan et al.

U.S. Appl. No. 29/332,128, filed Feb. 10, 2009, Sloan et al.

* cited by examiner

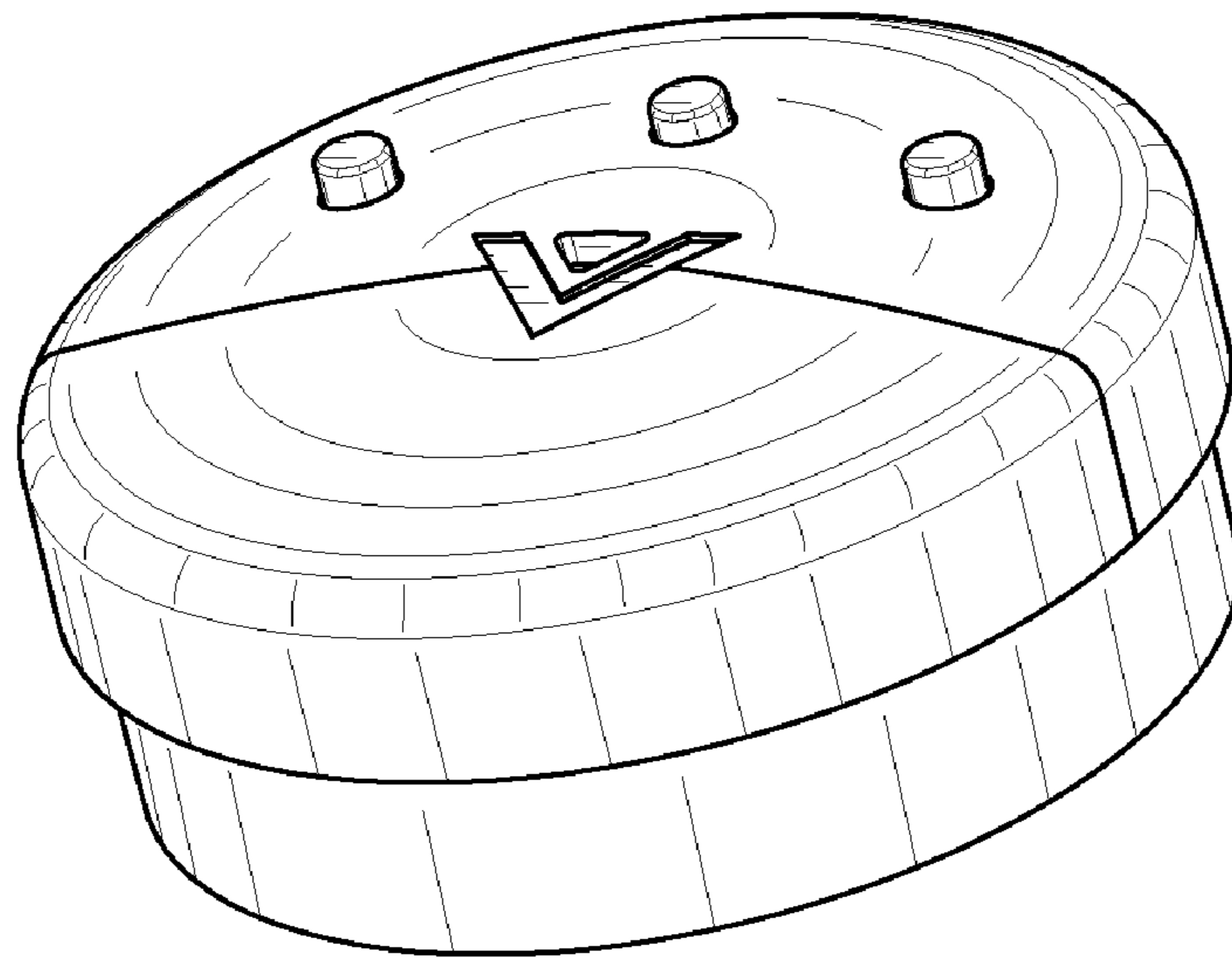

Fig. 1

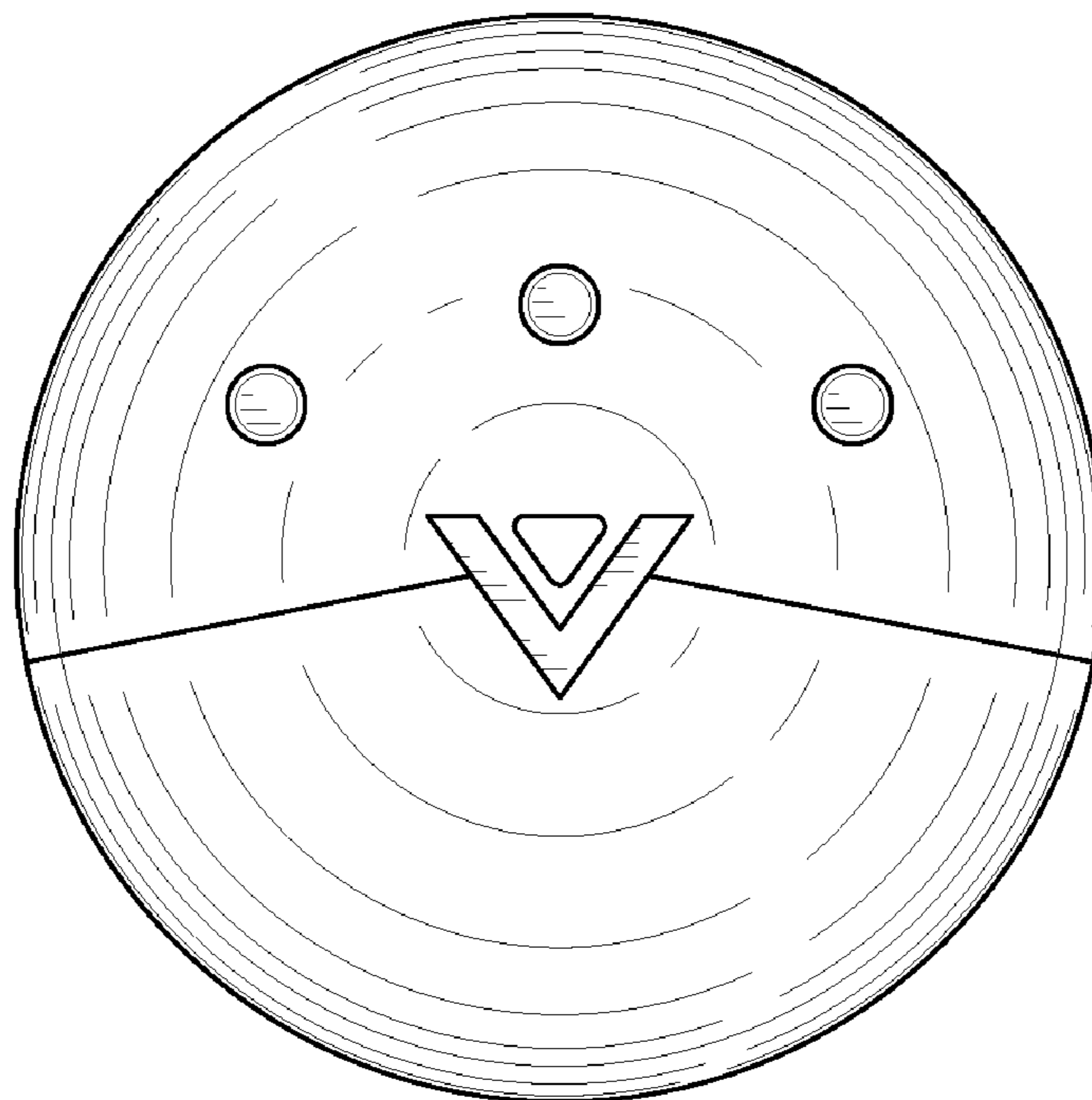

Fig. 2

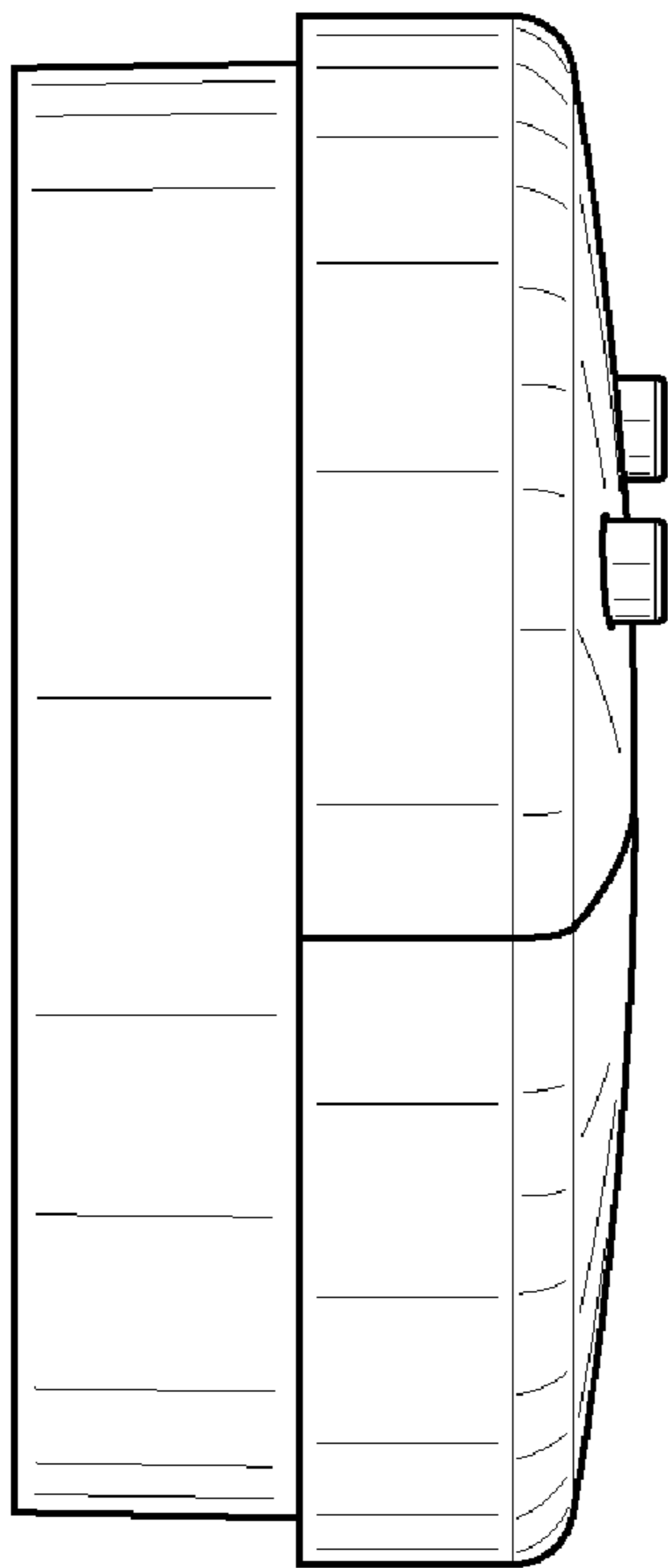

Fig. 3

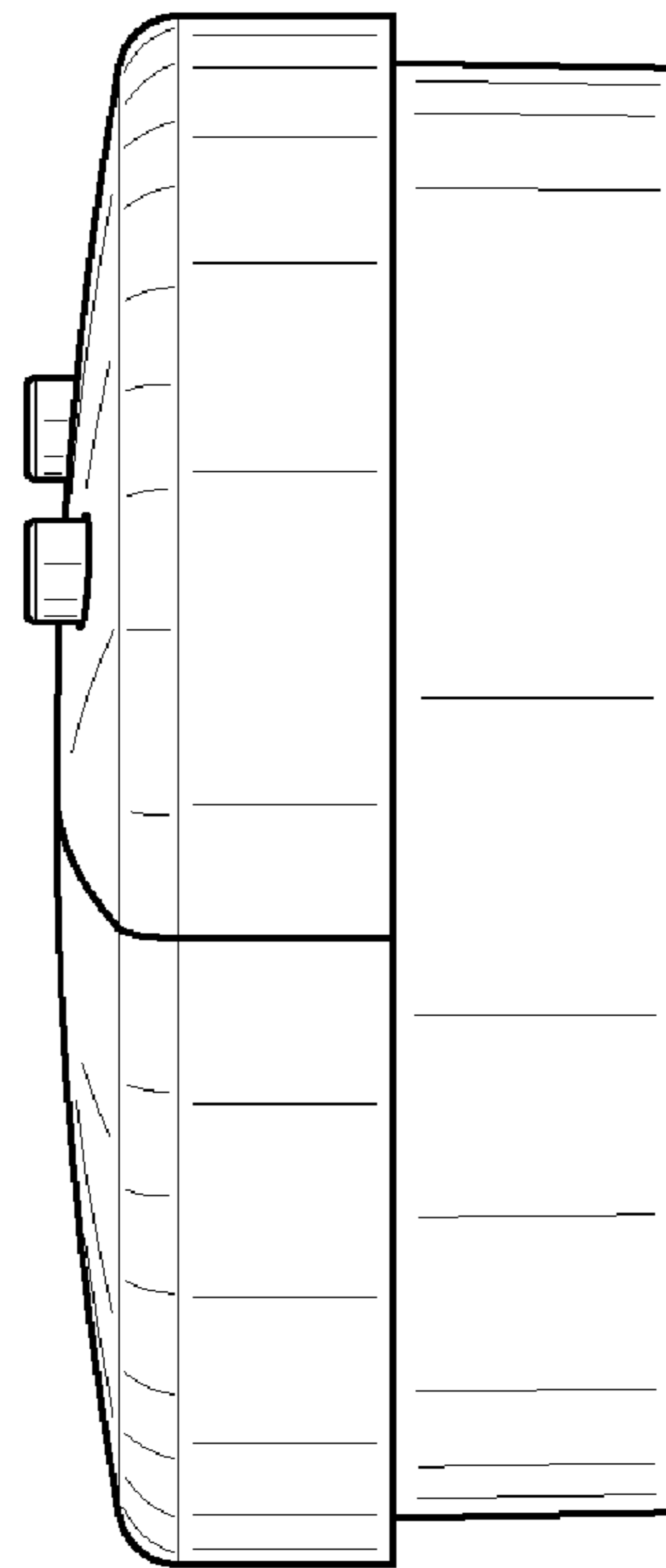

Fig. 4

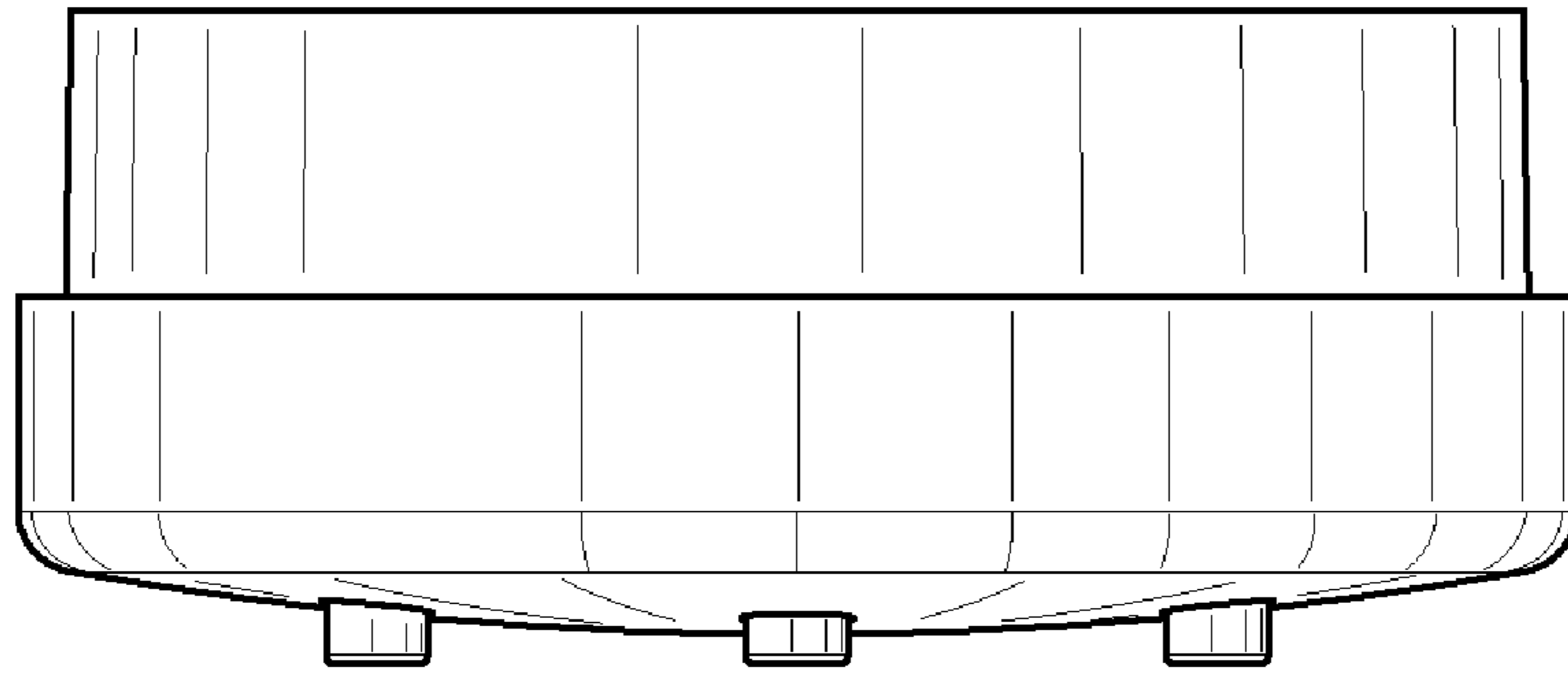

Fig. 5

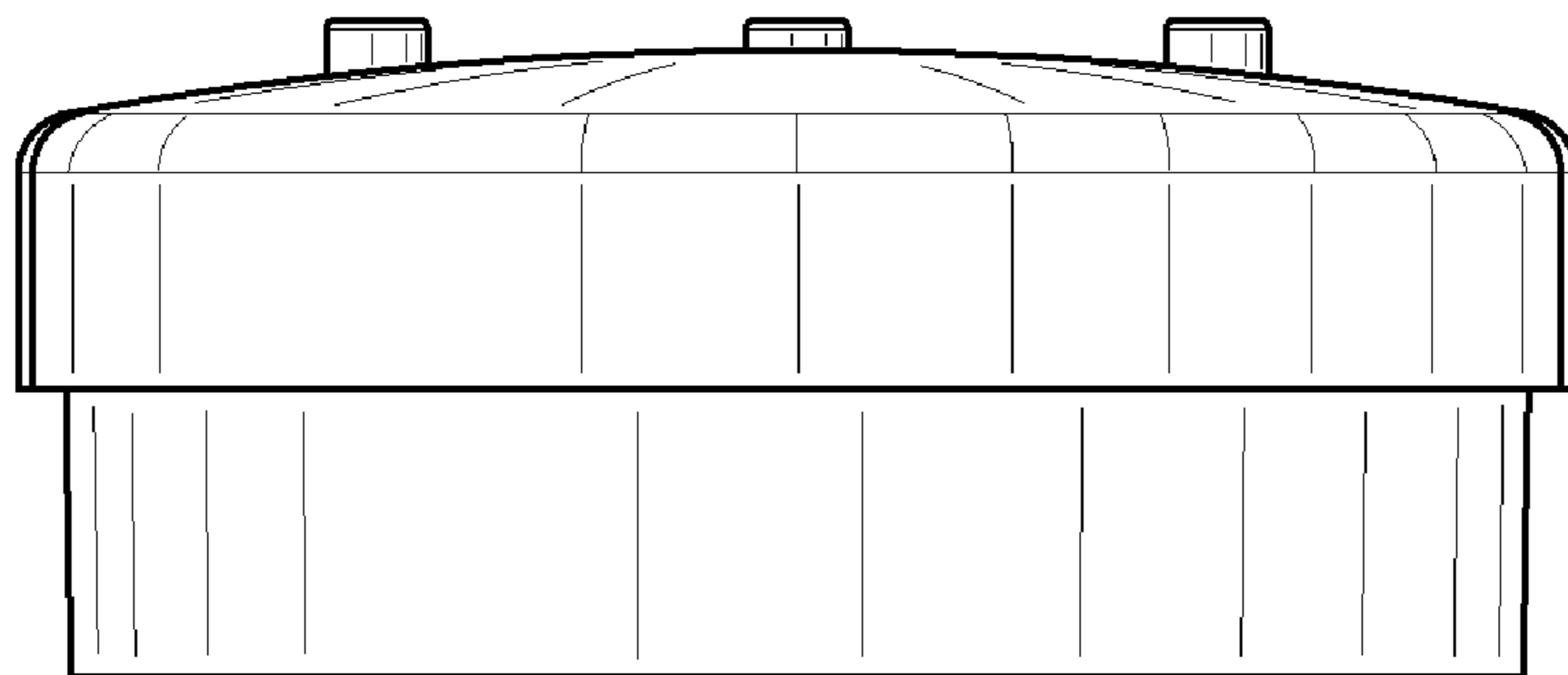

Fig. 6

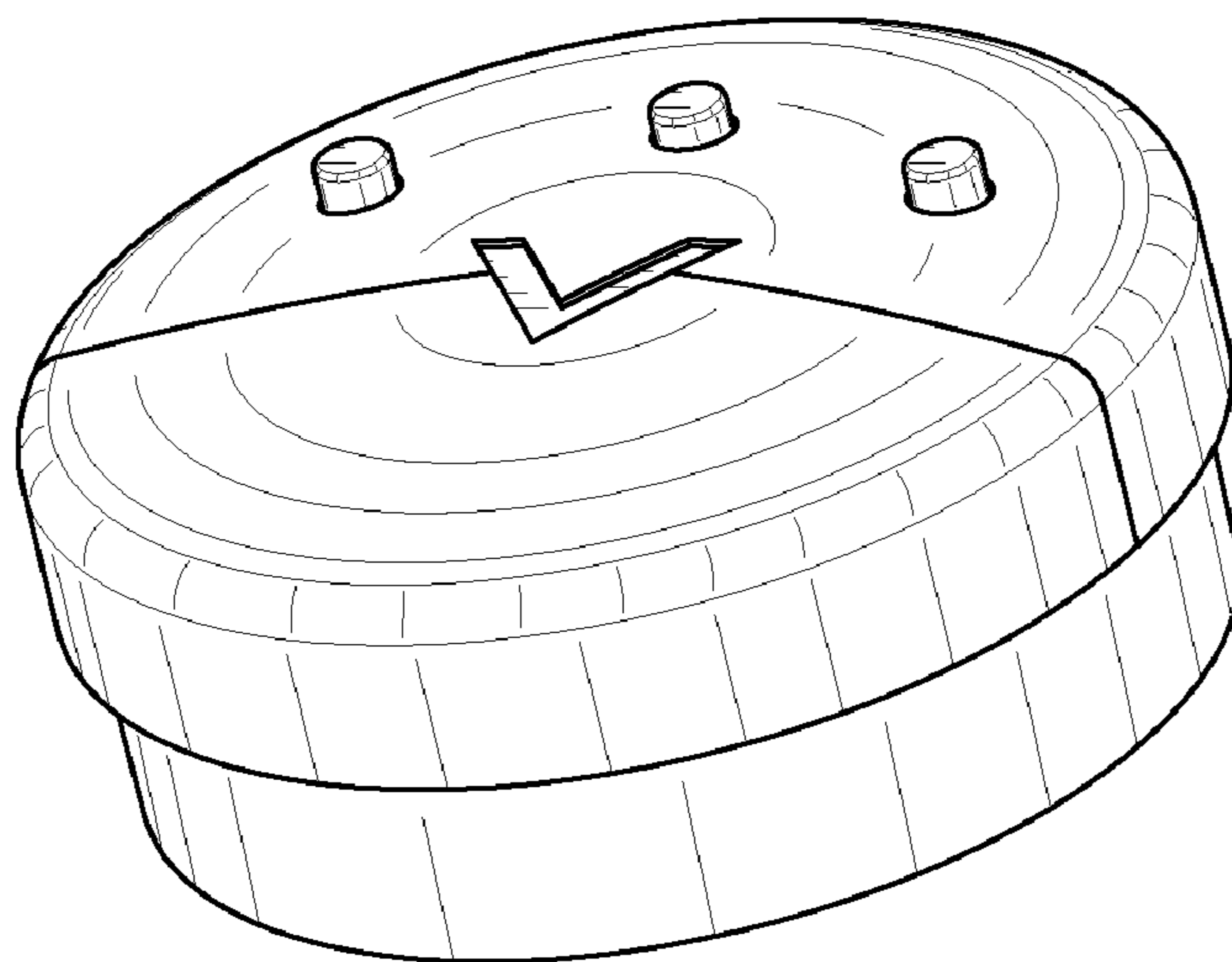

Fig. 7

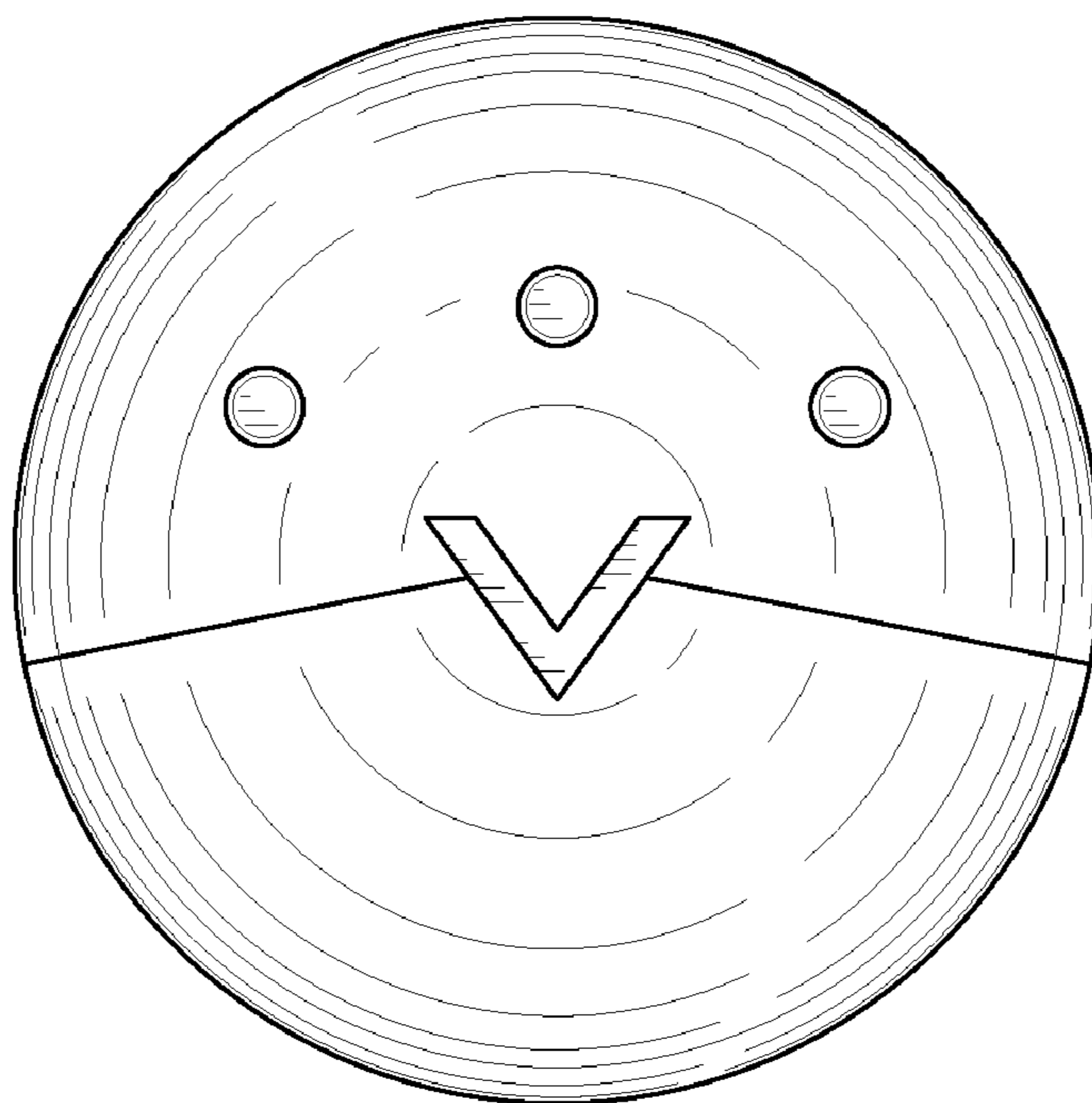

Fig. 8

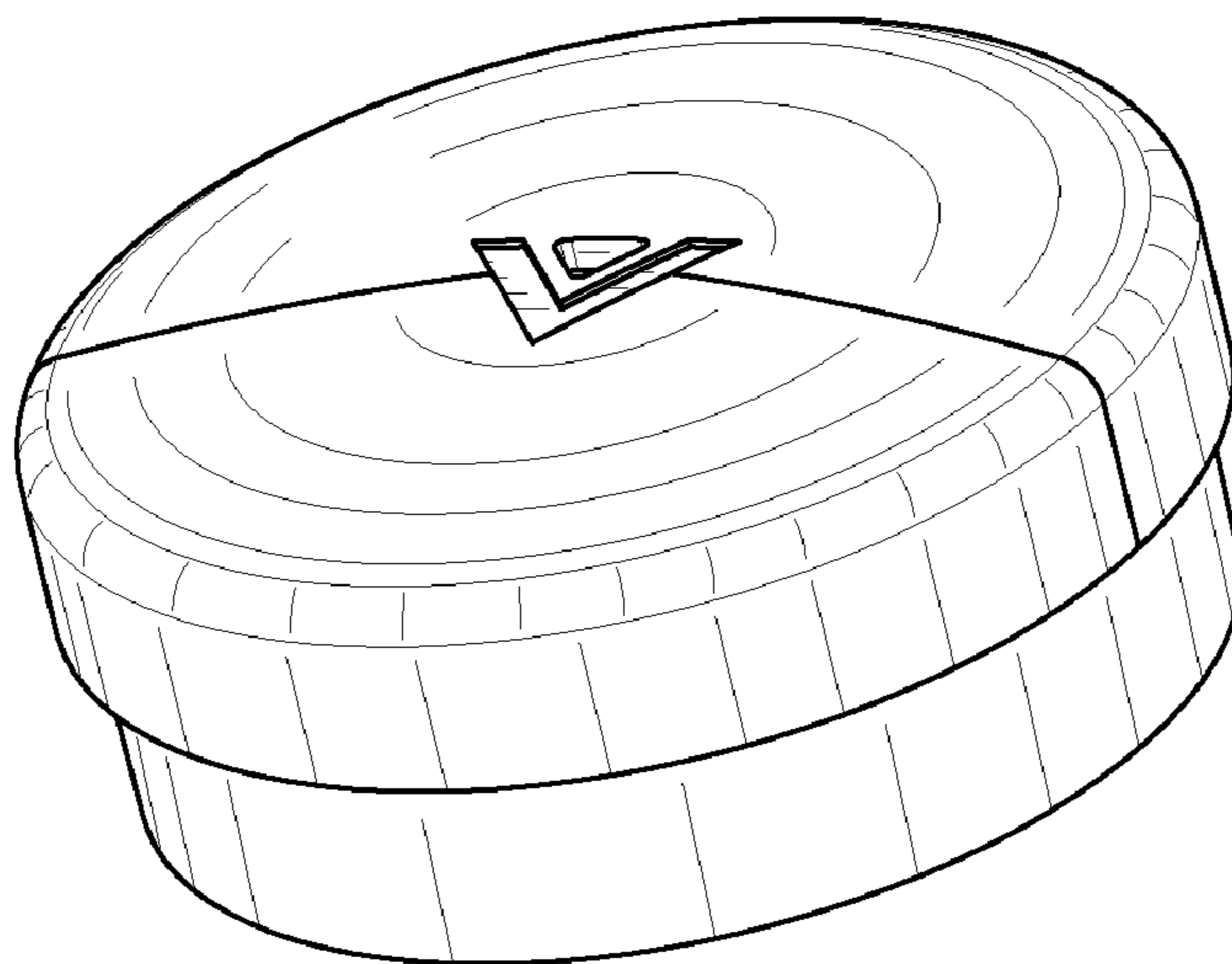

Fig. 9

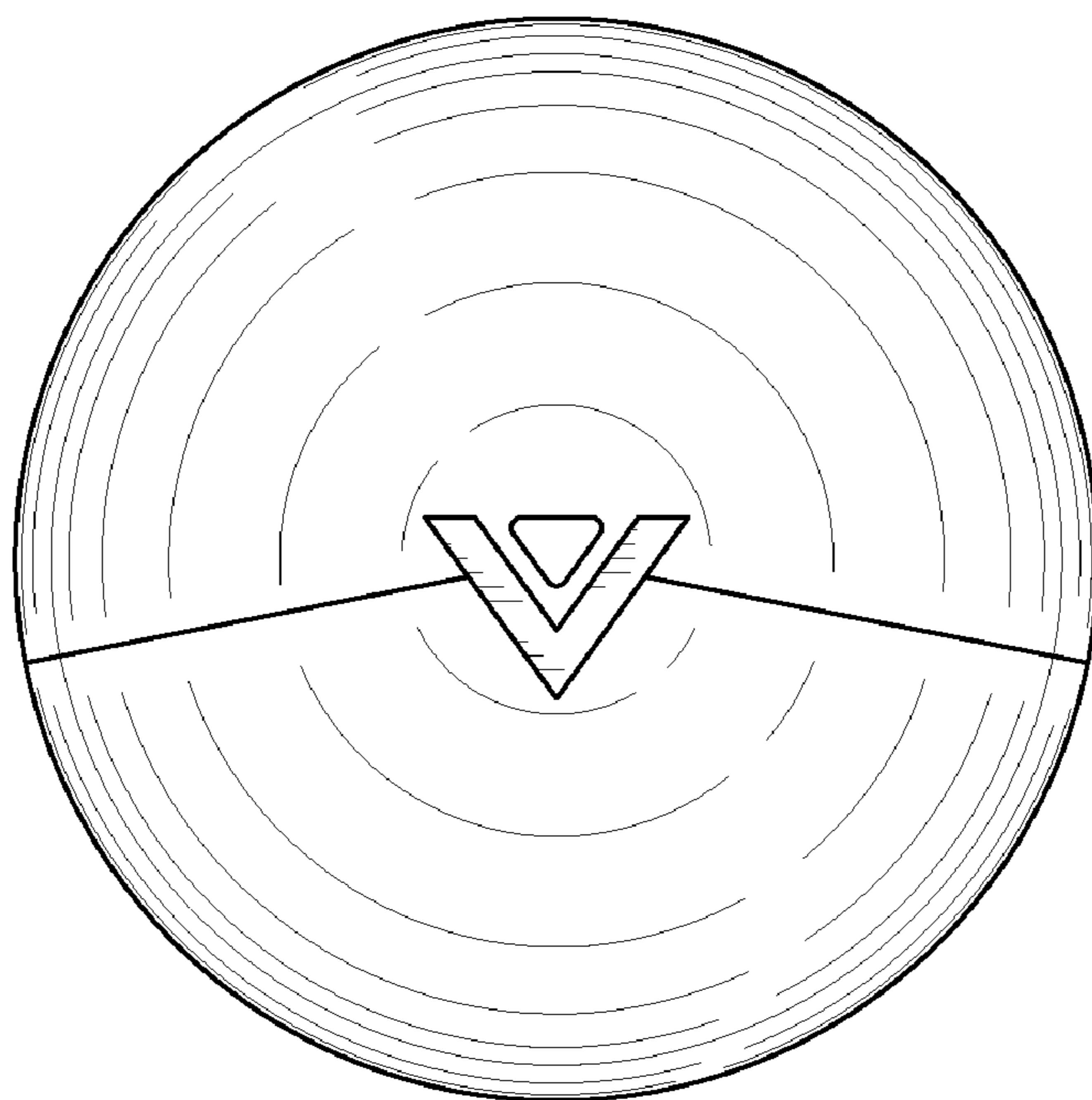

Fig. 10

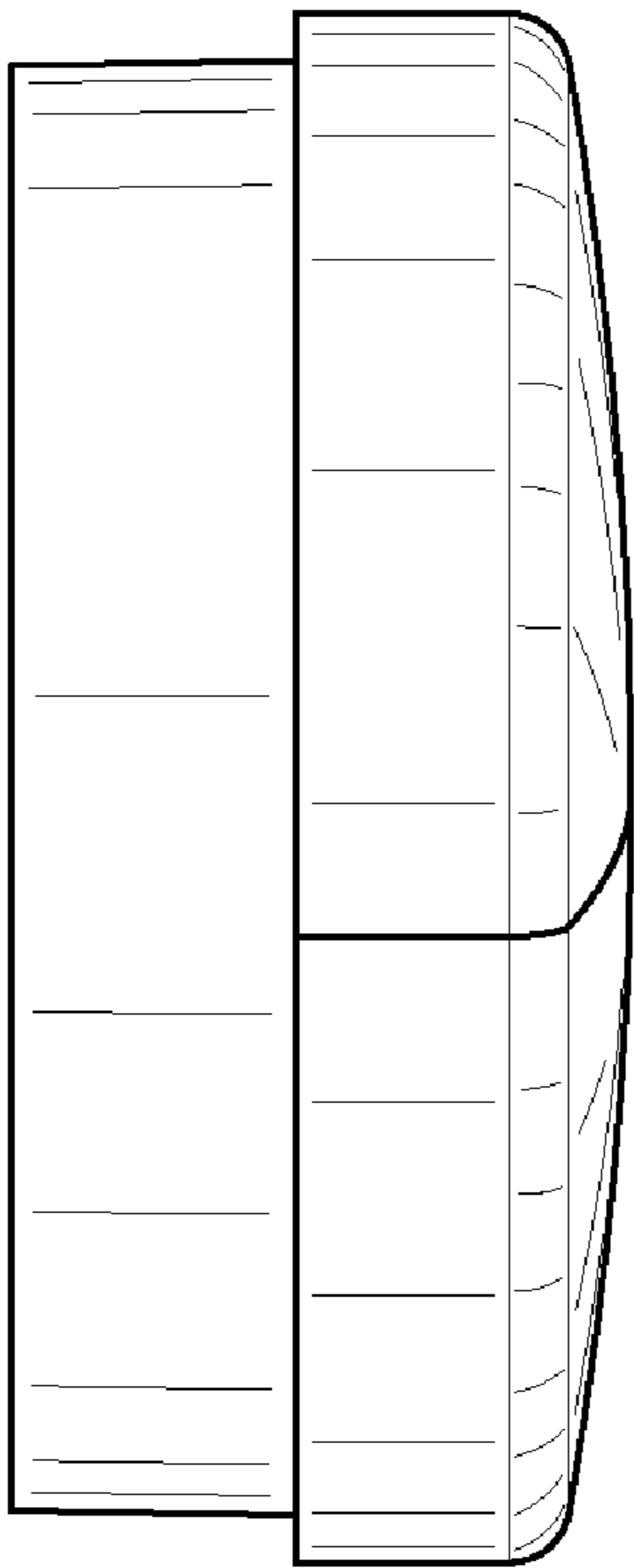

Fig. 11

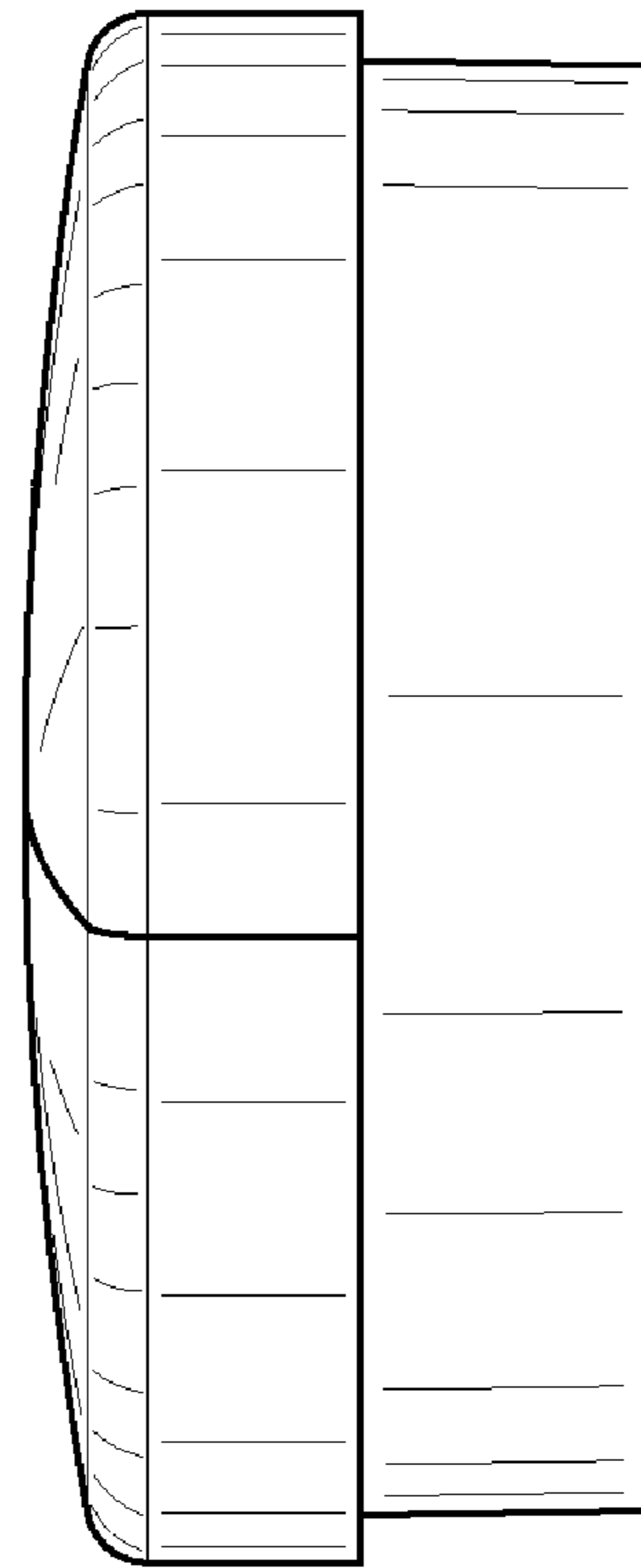

Fig. 12

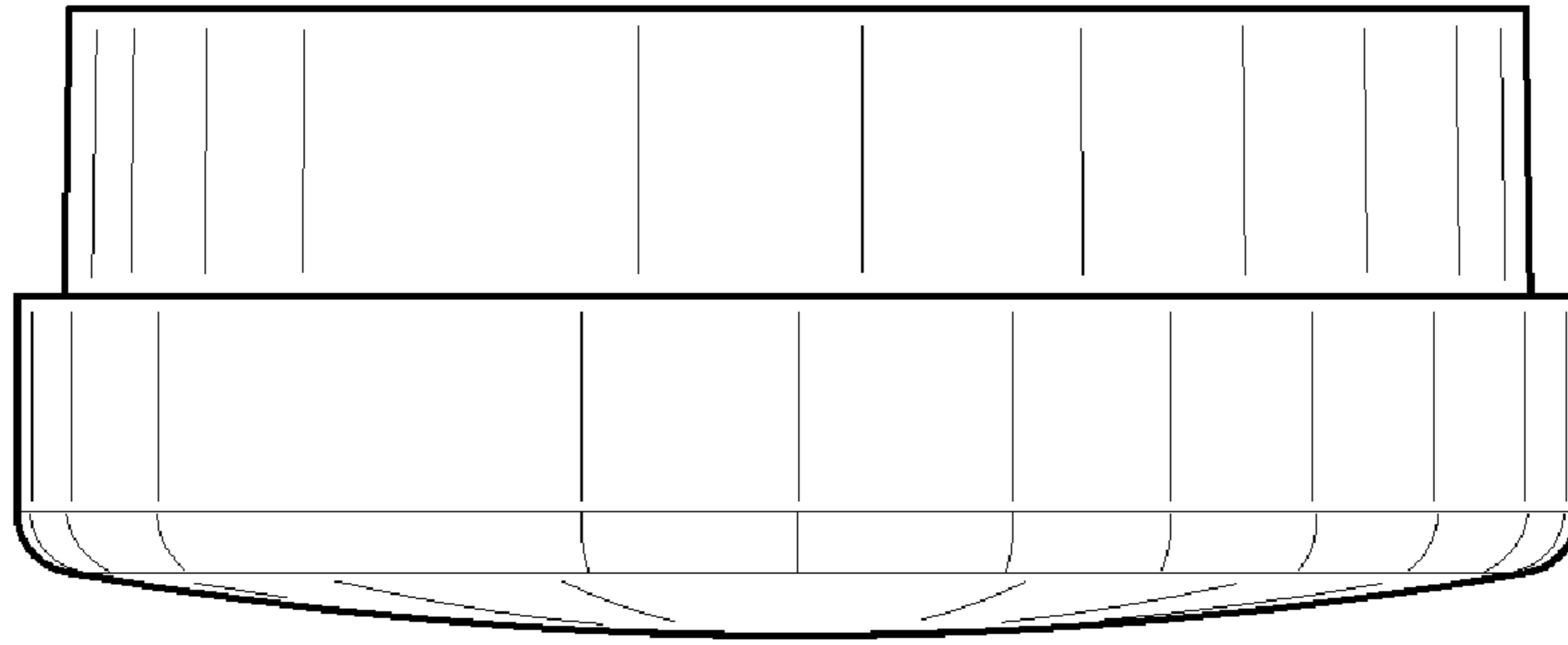

Fig. 13

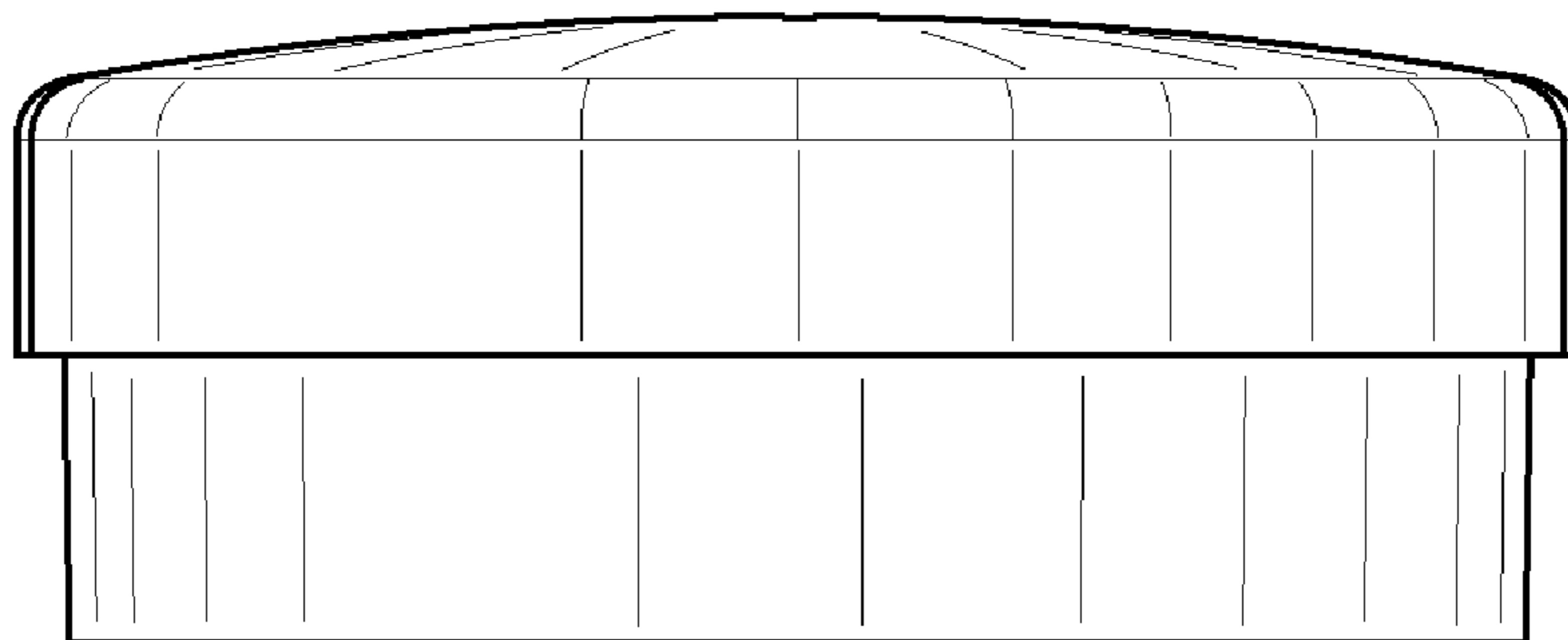

Fig. 14

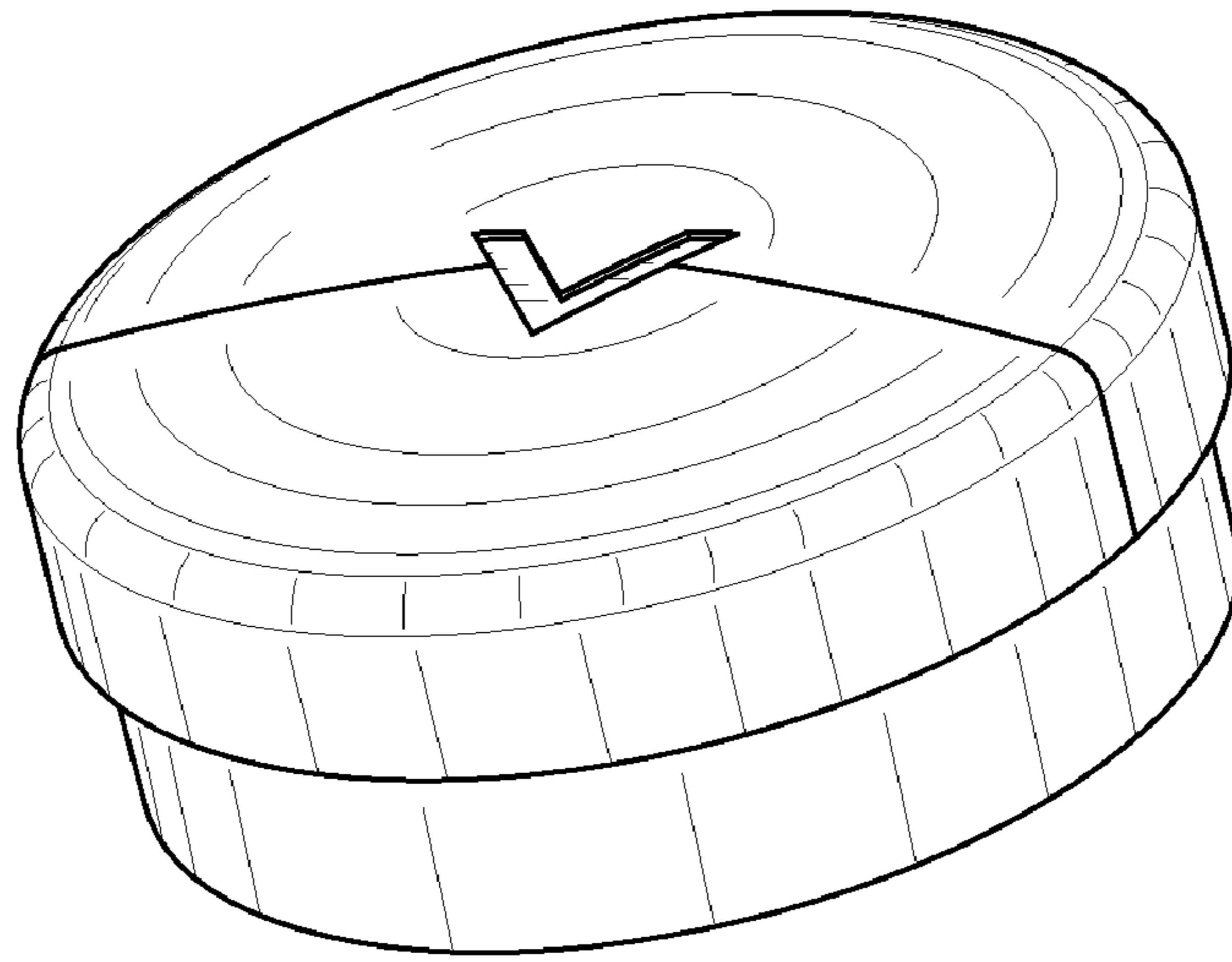

Fig. 15

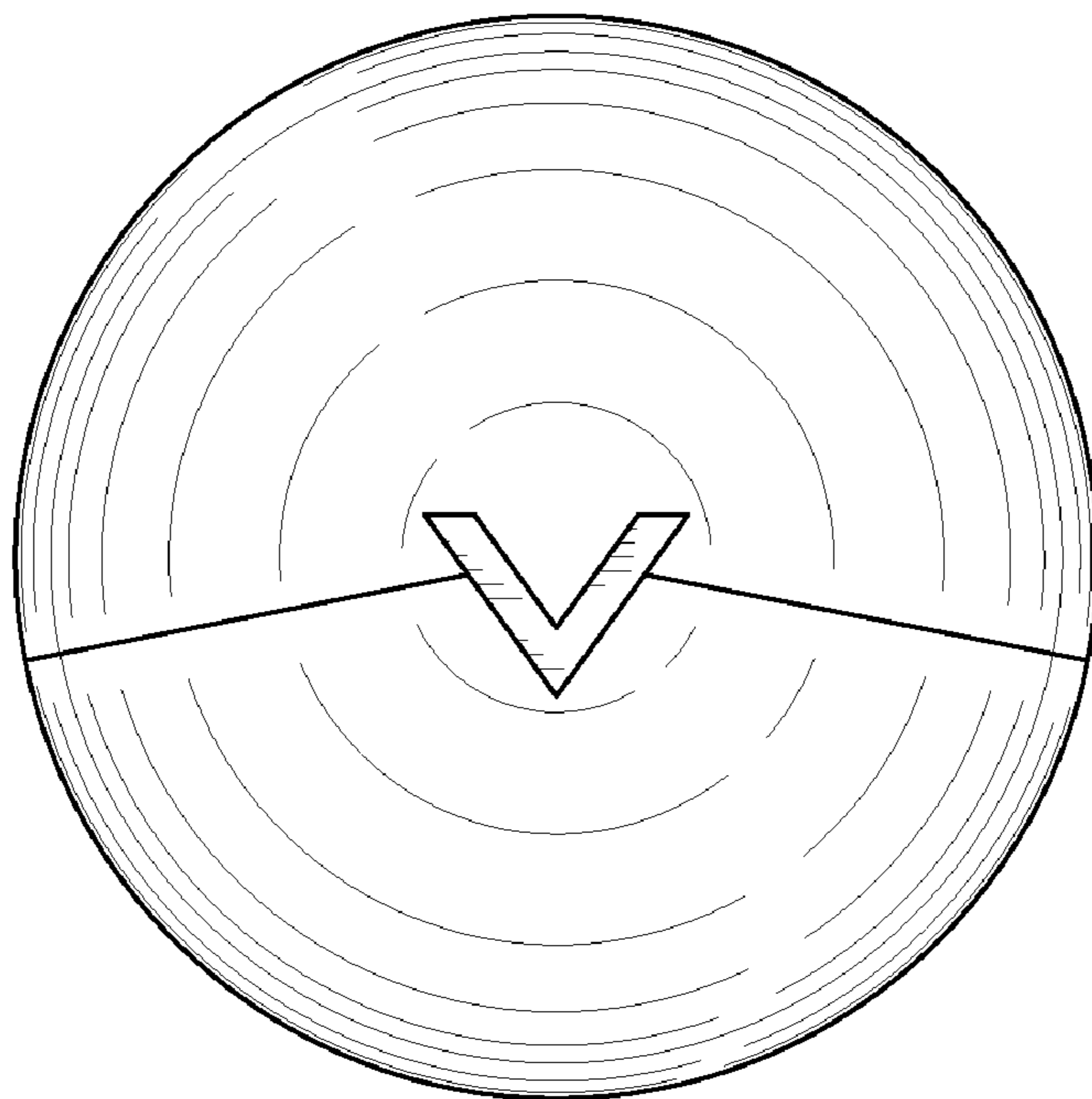

Fig. 16

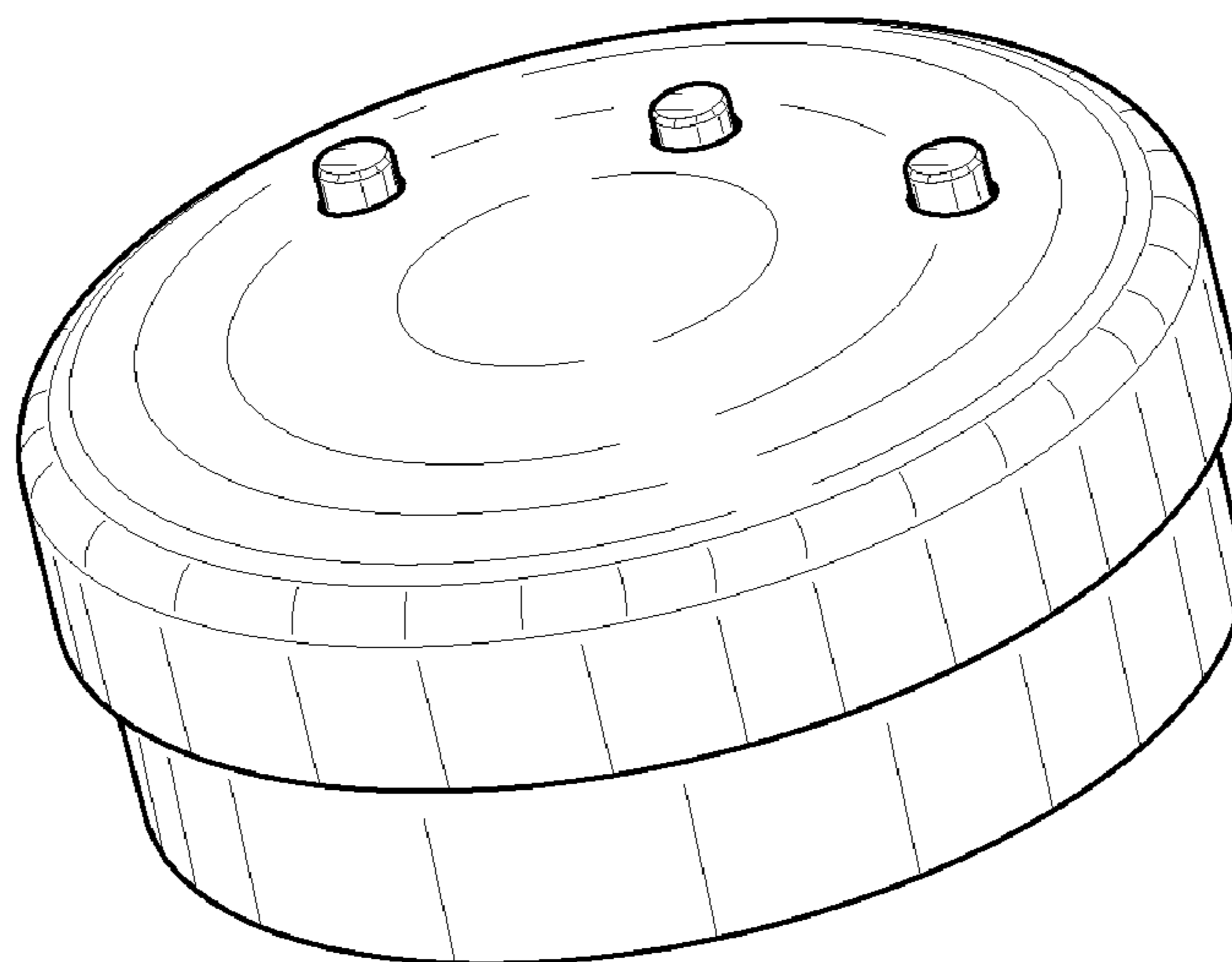

Fig. 17

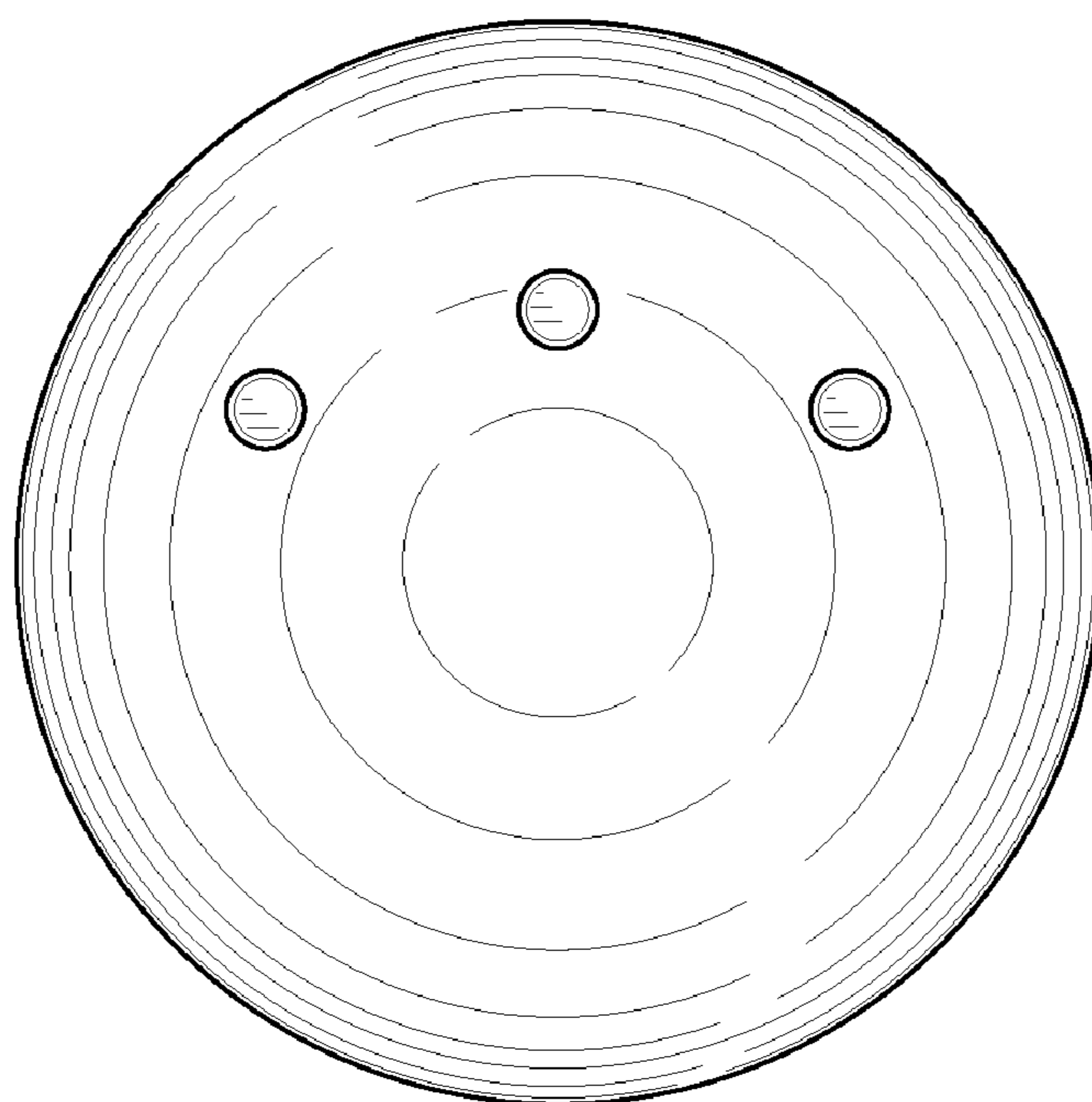

Fig. 18

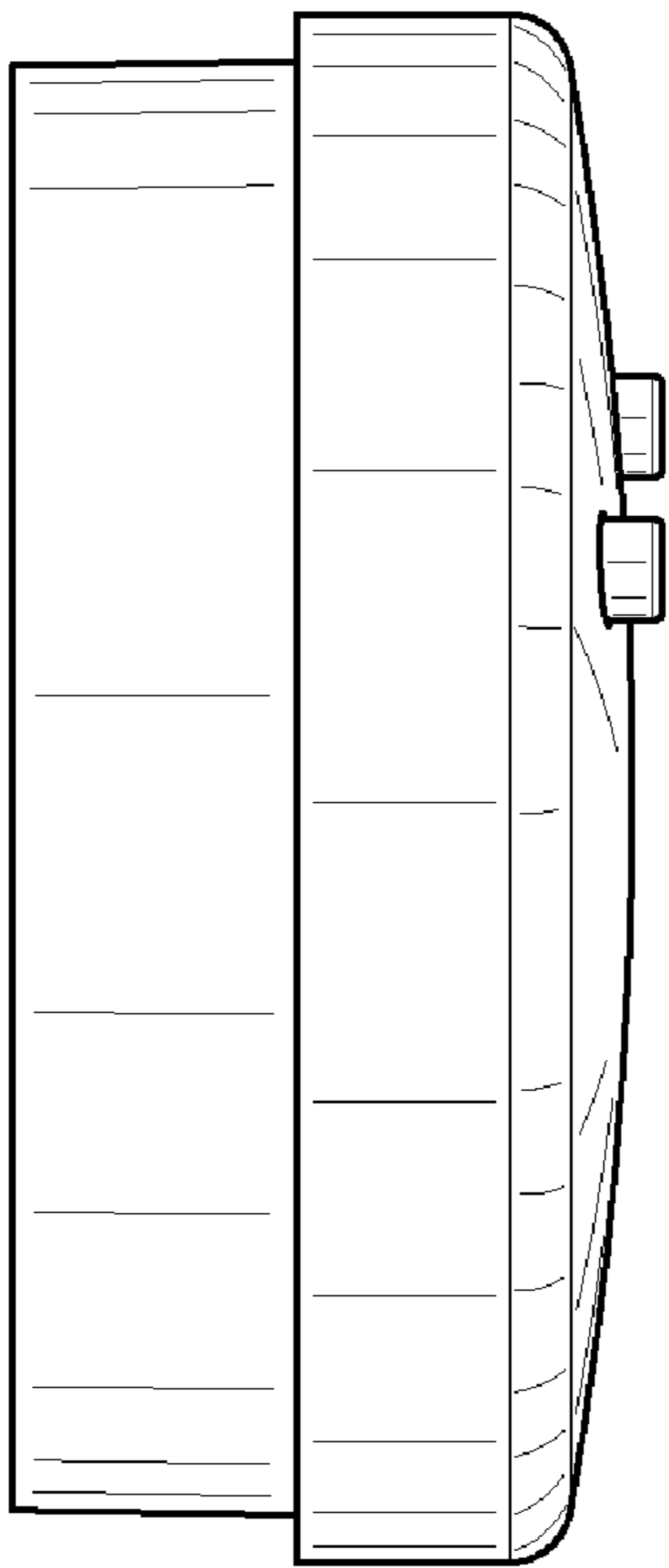

Fig. 19

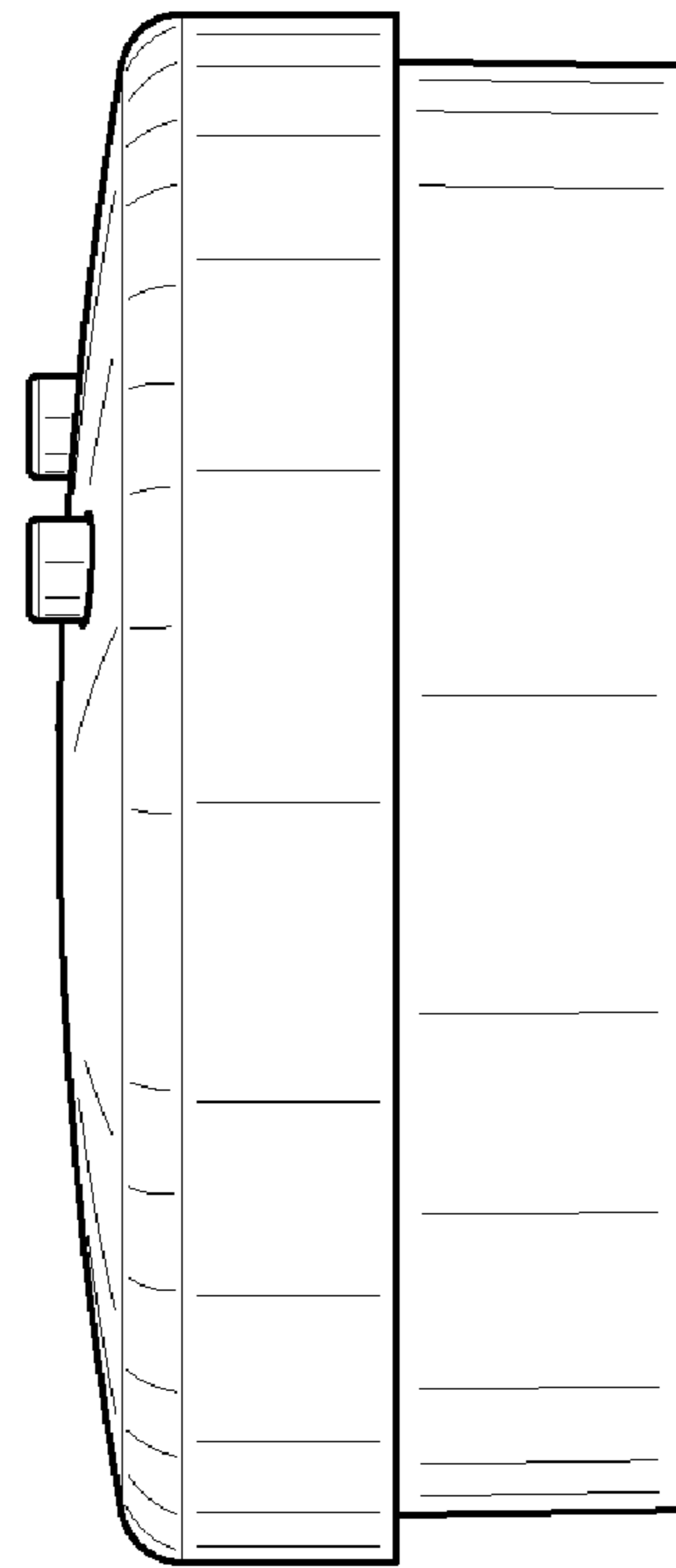

Fig. 20

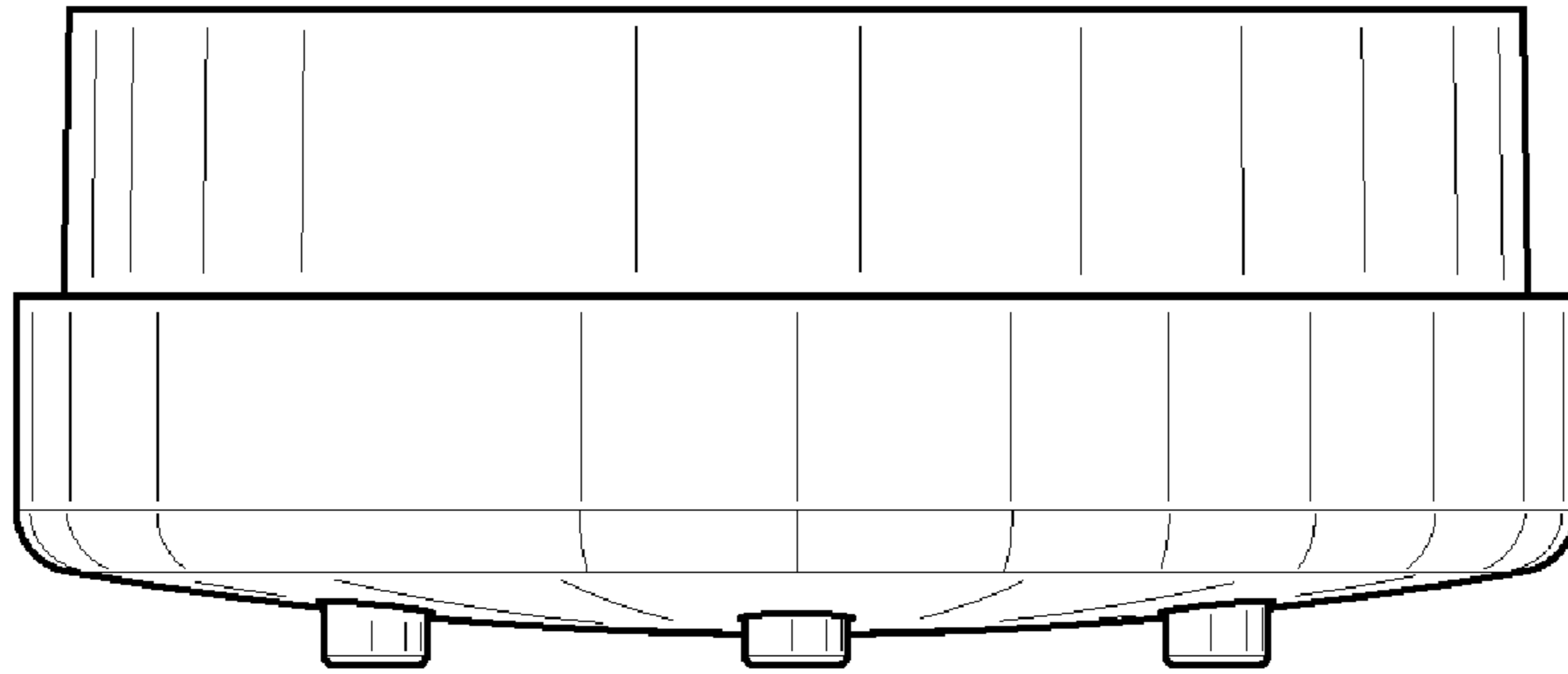

Fig. 21

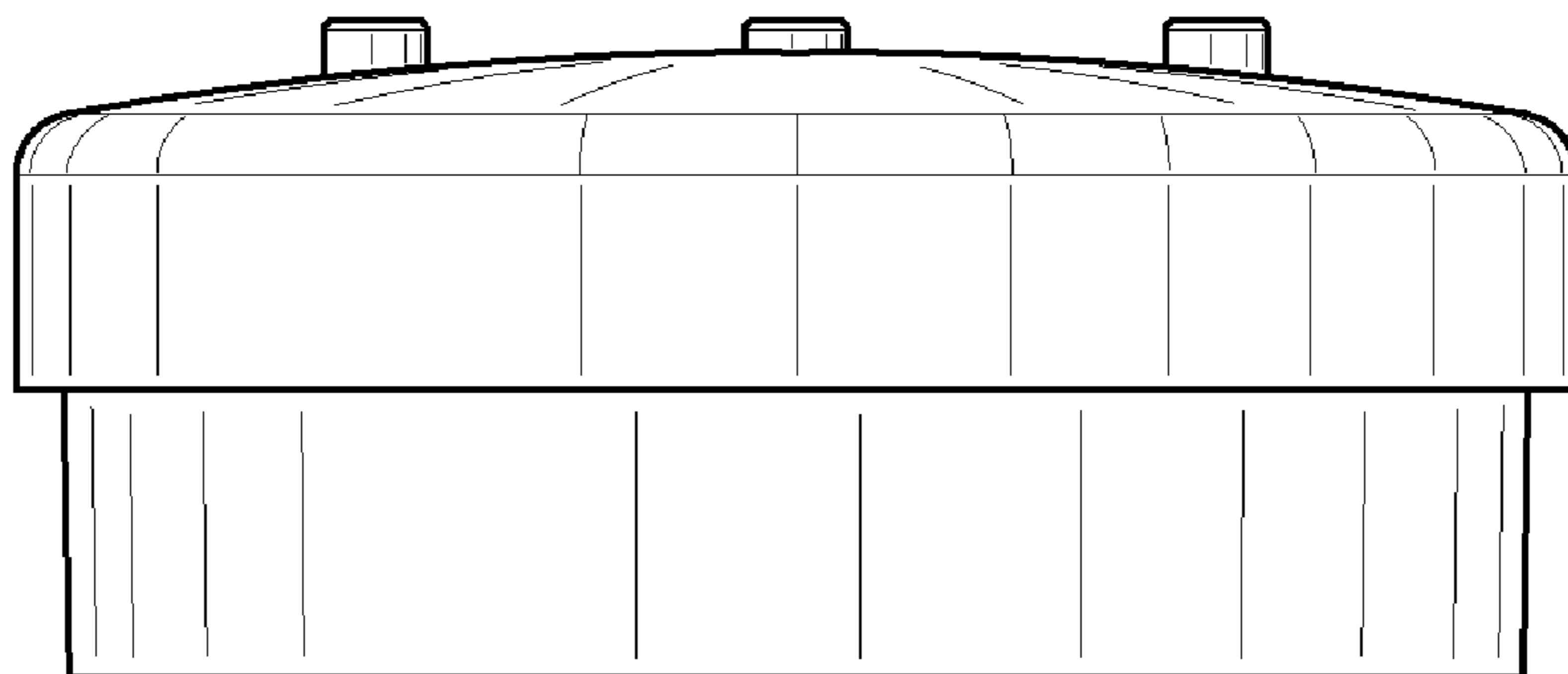

Fig. 22

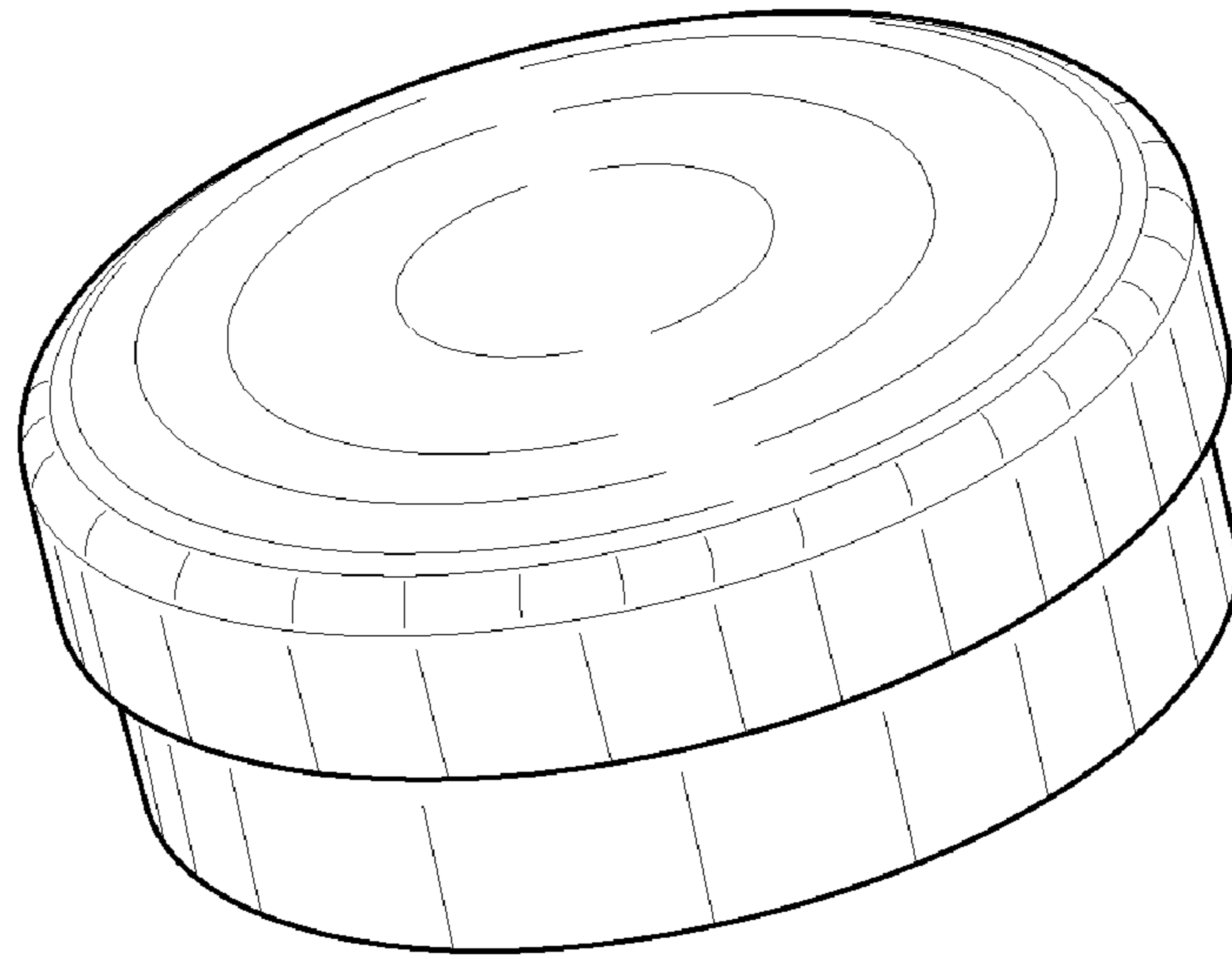

Fig. 23

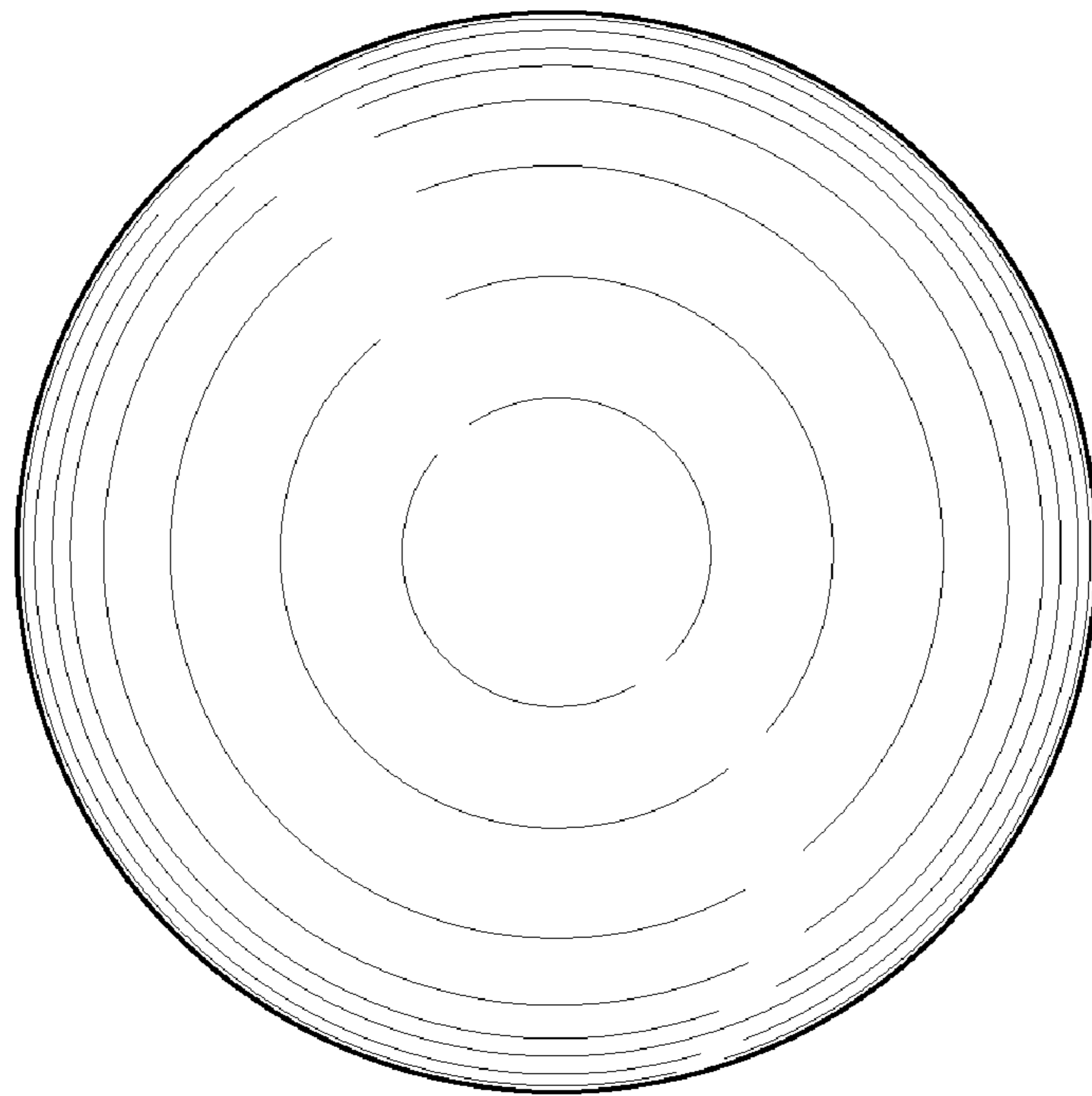

Fig. 24

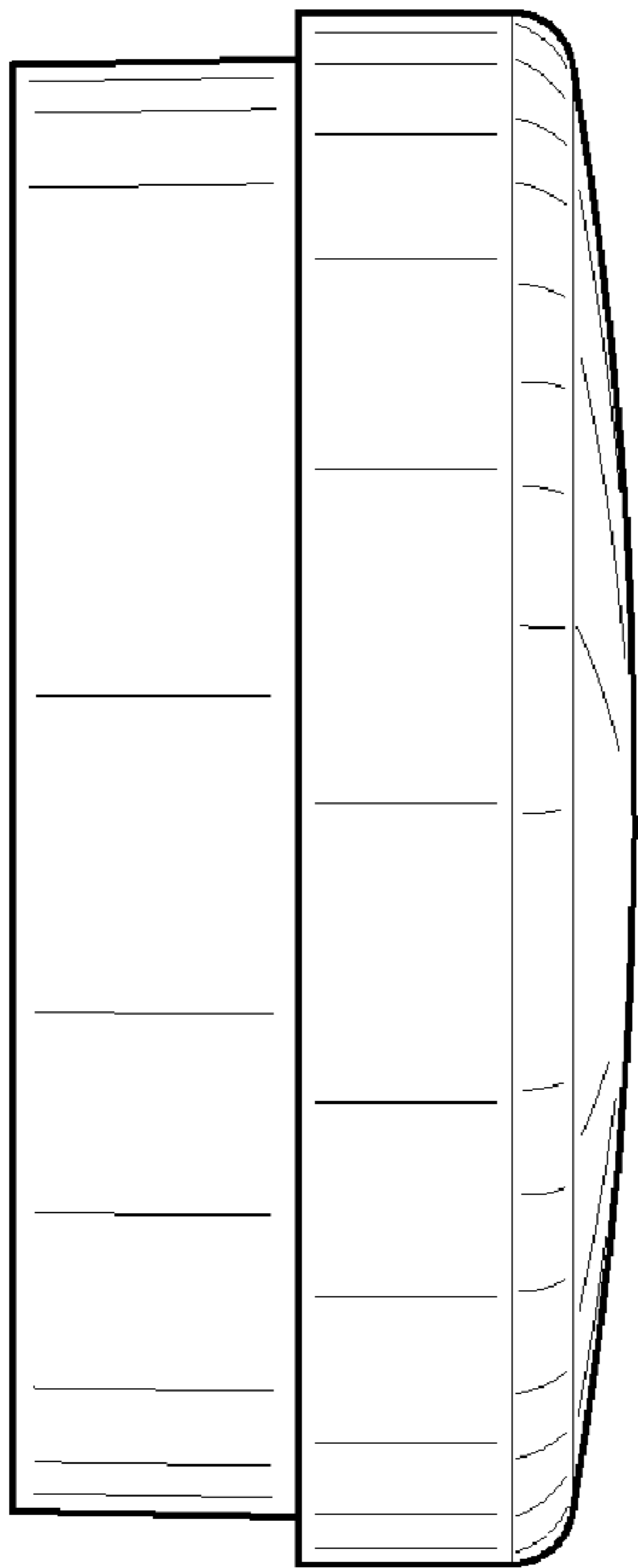

Fig. 25

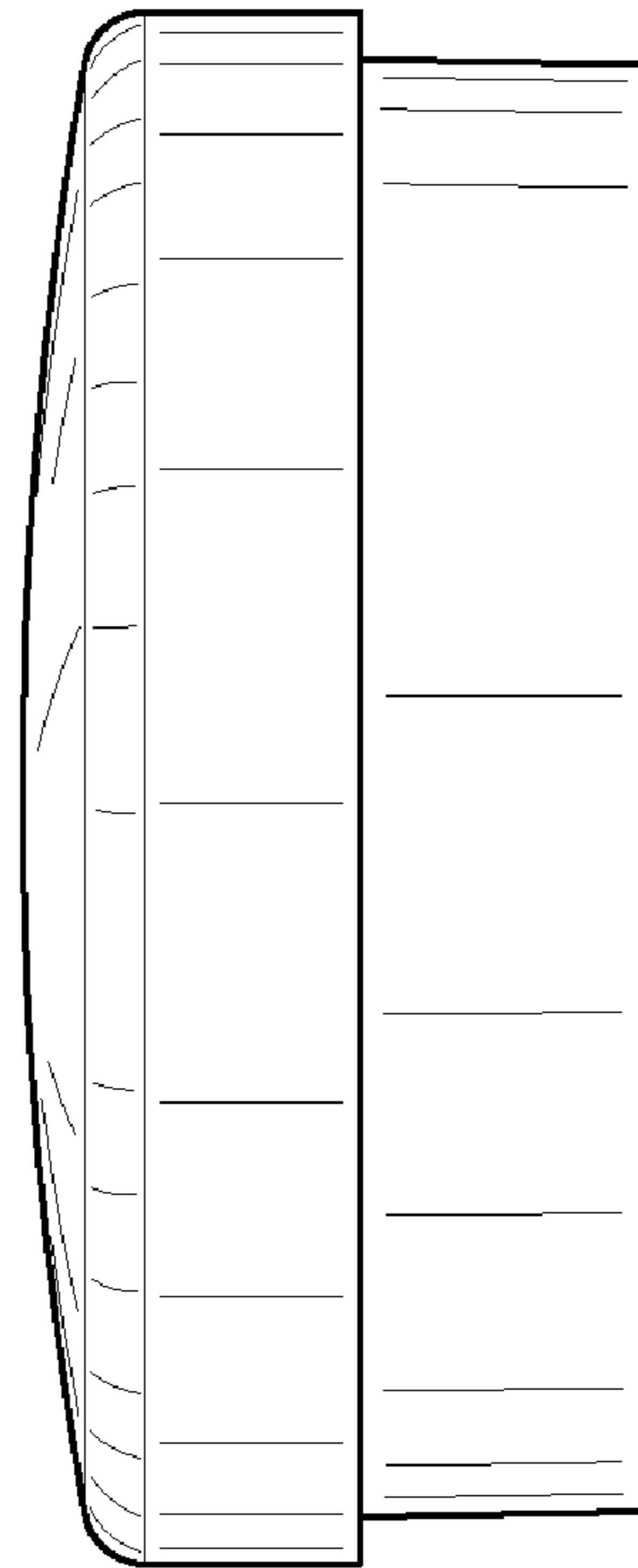

Fig. 26

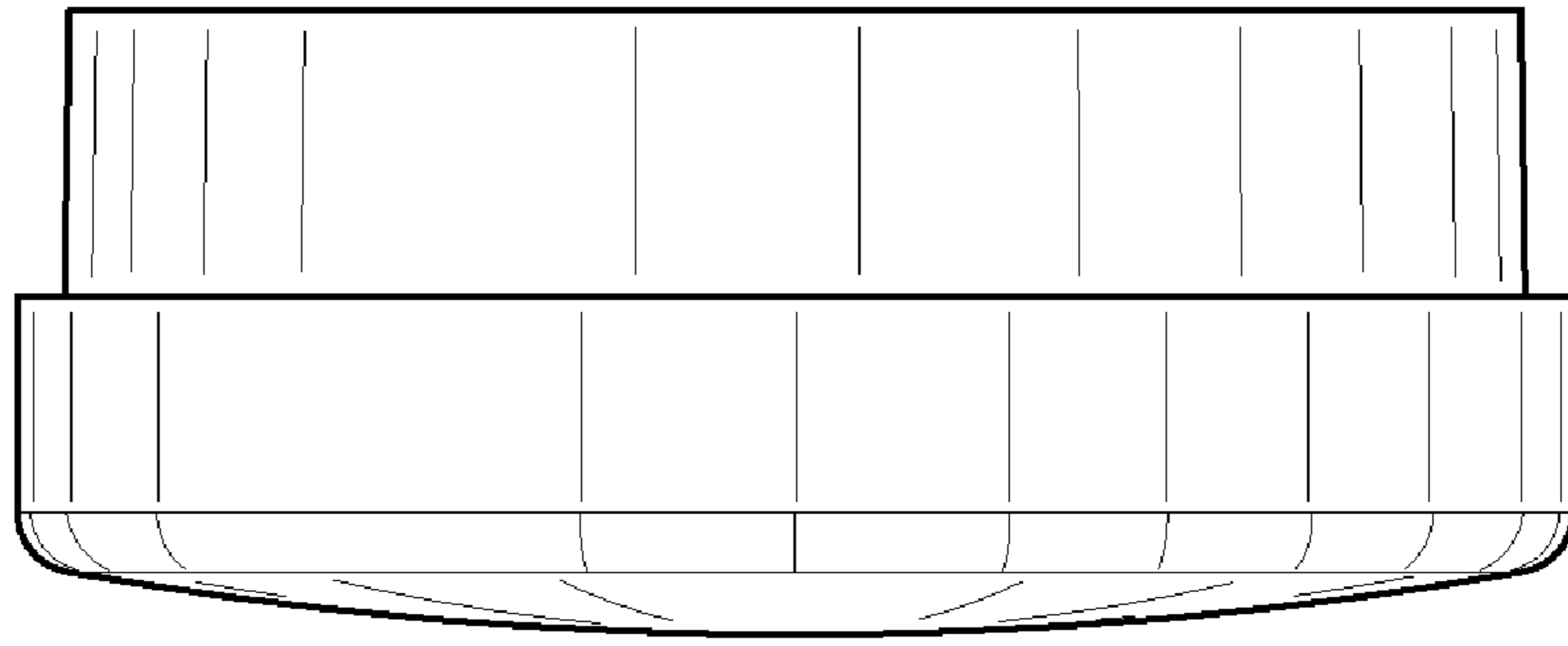

Fig. 27

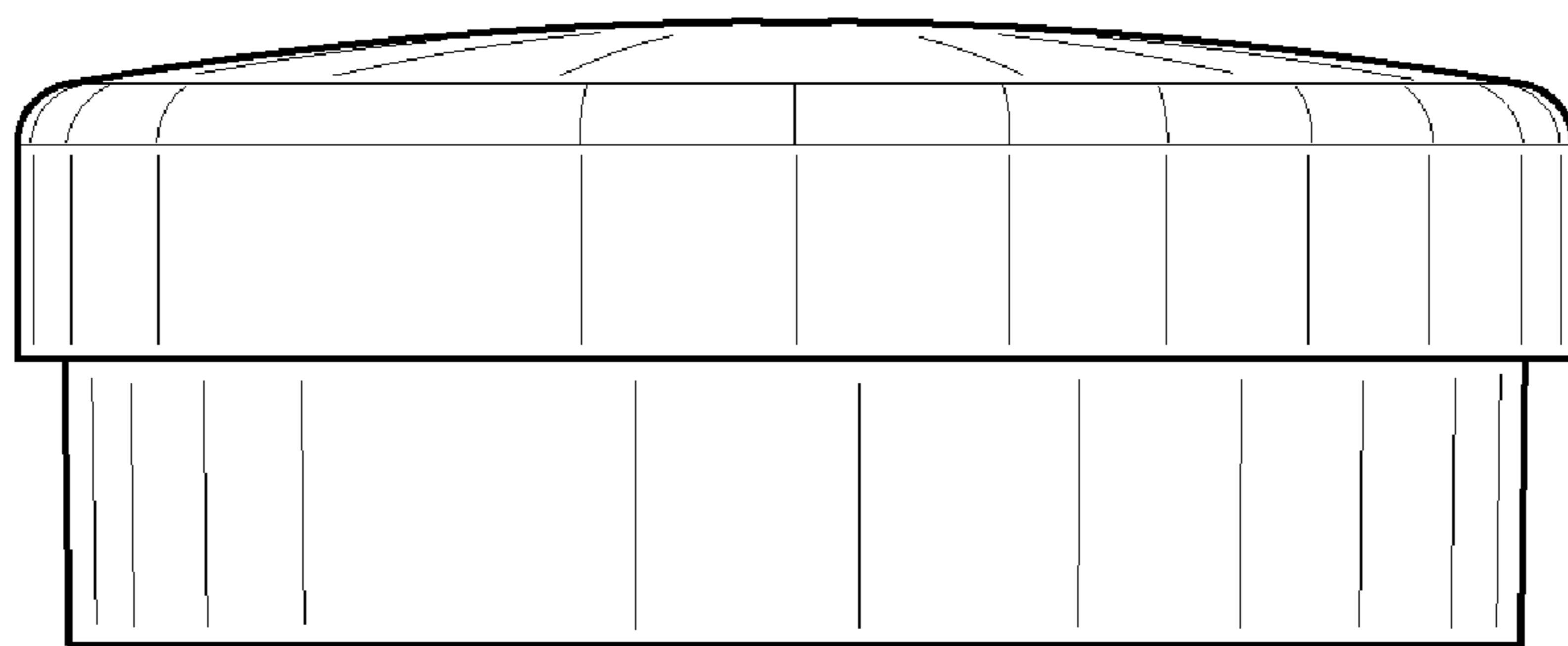

Fig. 28