



US00D602043S

(12) **United States Design Patent**
Linnig

(10) **Patent No.:** **US D602,043 S**
(45) **Date of Patent:** **** Oct. 13, 2009**

(54) **HUB FOR AN ELECTROMAGNETIC COUPLING FOR MOTOR VEHICLES**

(75) Inventor: **Karl Heinz Linnig**, Markdorf (DE)

(73) Assignee: **Kendrion Linnig GmbH** (DE)

(**) Term: **14 Years**

(21) Appl. No.: **29/246,169**

(22) Filed: **Mar. 3, 2006**

(30) **Foreign Application Priority Data**

Sep. 6, 2005 (DE) 405 04 629

(51) **LOC (9) Cl.** **15-01**

(52) **U.S. Cl.** **D15/5**

(58) **Field of Classification Search** D15/1-5,
D15/143; 192/84.1, 84.31, 84.9, 84.961,
192/200, 84.951; 335/296-297, 279, 281-282;
72/340; 29/602.1, 607; D8/387-389; 384/412,
384/428; 248/174, 176.1, 188.4, 354.3

See application file for complete search history.

(56) **References Cited**

U.S. PATENT DOCUMENTS

3,156,125 A * 11/1964 Straub 74/126
3,986,752 A * 10/1976 Bogar et al. 384/422
D245,366 S * 8/1977 Berglund D15/143
D252,703 S * 8/1979 Cupit D23/259
RE30,461 E * 12/1980 Bogar et al. 384/428
D258,828 S * 4/1981 Zrobek D18/58
4,891,619 A * 1/1990 Booth et al. 335/296
4,951,797 A * 8/1990 Booth et al. 192/107 R
5,096,036 A * 3/1992 Booth et al. 192/107 R
5,125,255 A * 6/1992 Brown et al. 72/334
D334,051 S * 3/1993 Fell, Sr. D23/262

5,250,921 A * 10/1993 Van Laningham et al. .. 335/296
5,497,869 A * 3/1996 Muirhead et al. 192/84.96
D371,138 S * 6/1996 Waskiewicz D15/5
D371,139 S * 6/1996 Waskiewicz D15/5
D372,033 S * 7/1996 Kanemitsu D15/5
5,971,618 A * 10/1999 Ledingham 384/438
D425,081 S * 5/2000 Hartmann D15/5
D444,802 S * 7/2001 Dyson et al. D15/143
6,409,004 B1 6/2002 Kawada et al.
D460,770 S * 7/2002 Ochiai D15/143
D497,536 S * 10/2004 Fujiwara D8/354
6,823,974 B2 11/2004 Hayashi

FOREIGN PATENT DOCUMENTS

DE 3504193 A1 8/1985
GB 2155565 A 9/1985

* cited by examiner

Primary Examiner—Ian Simmons

Assistant Examiner—Wan Laymon

(74) *Attorney, Agent, or Firm*—Faegre & Benson LLP

(57) **CLAIM**

The ornamental design of a hub for an electromagnetic coupling for motor vehicles, as shown.

DESCRIPTION

FIG. 1 is a top view of a hub for an electromagnetic coupling for motor vehicles.

FIG. 2 is an enlarged top view of the hub illustrated in FIG. 1; and,

FIG. 3 is a perspective view of the first embodiment illustrated in FIG. 1.

The broken lines in the drawings show the environment of the invention and form no part of the claimed design.

1 Claim, 3 Drawing Sheets

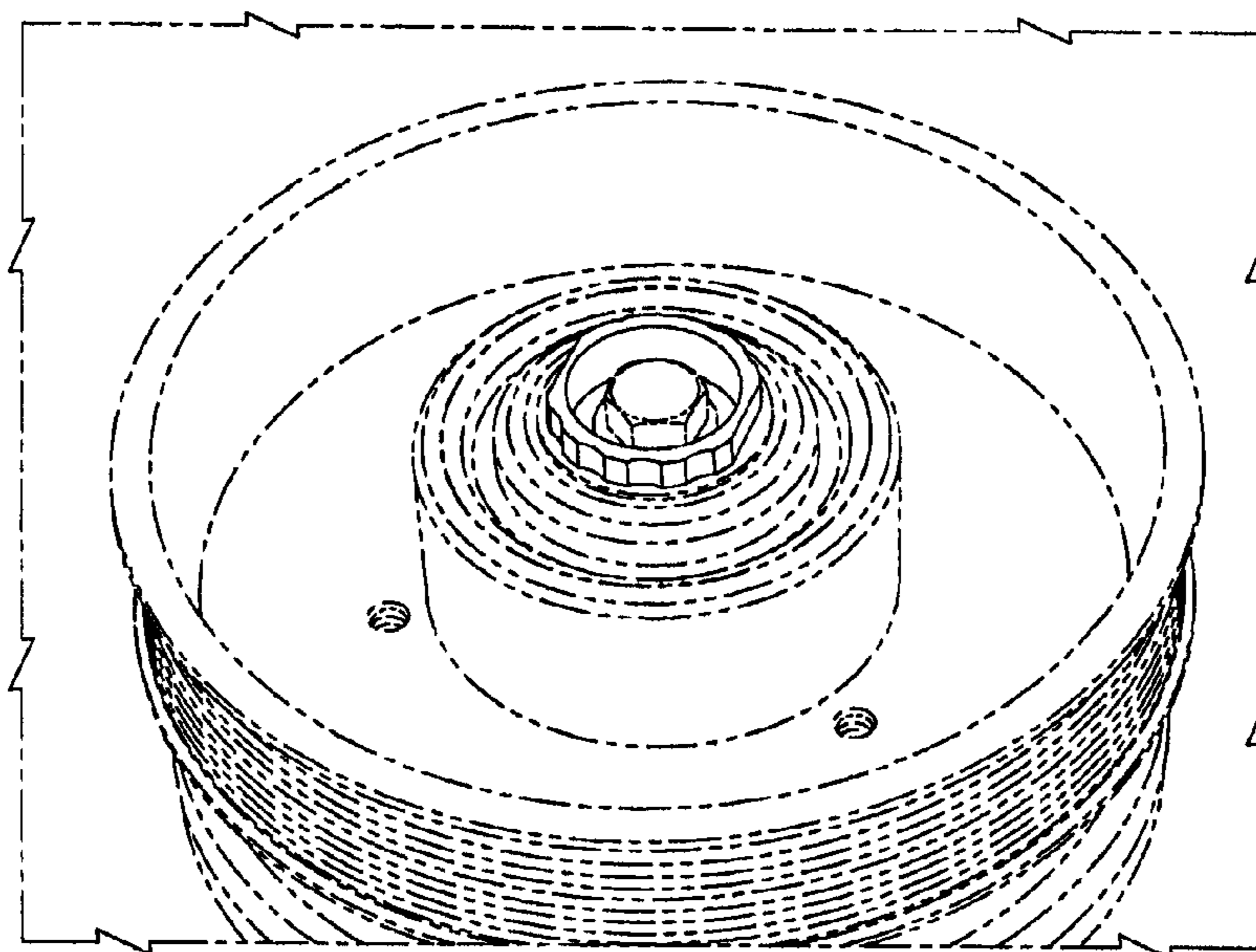

FIG. 1

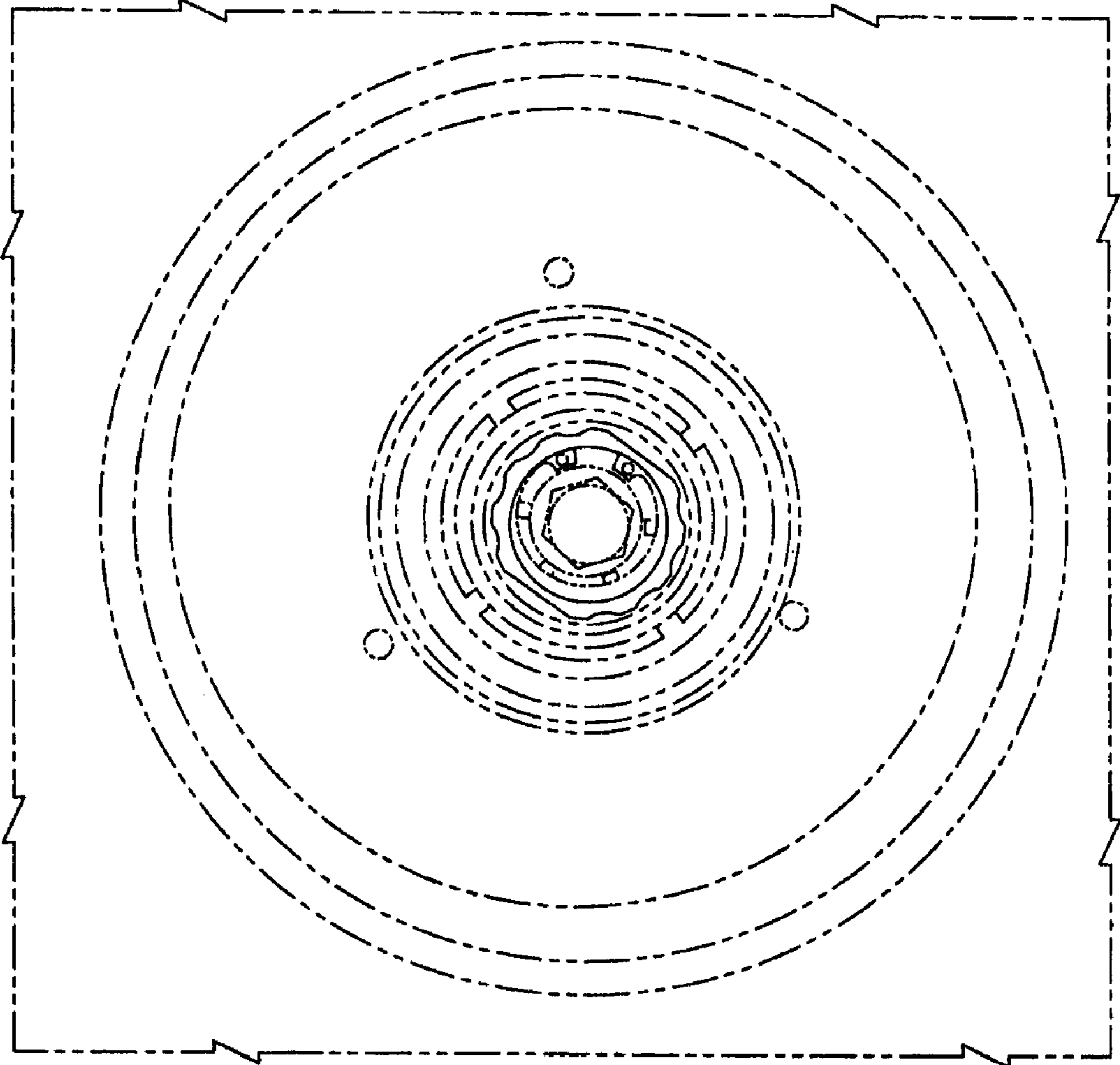

FIG. 2

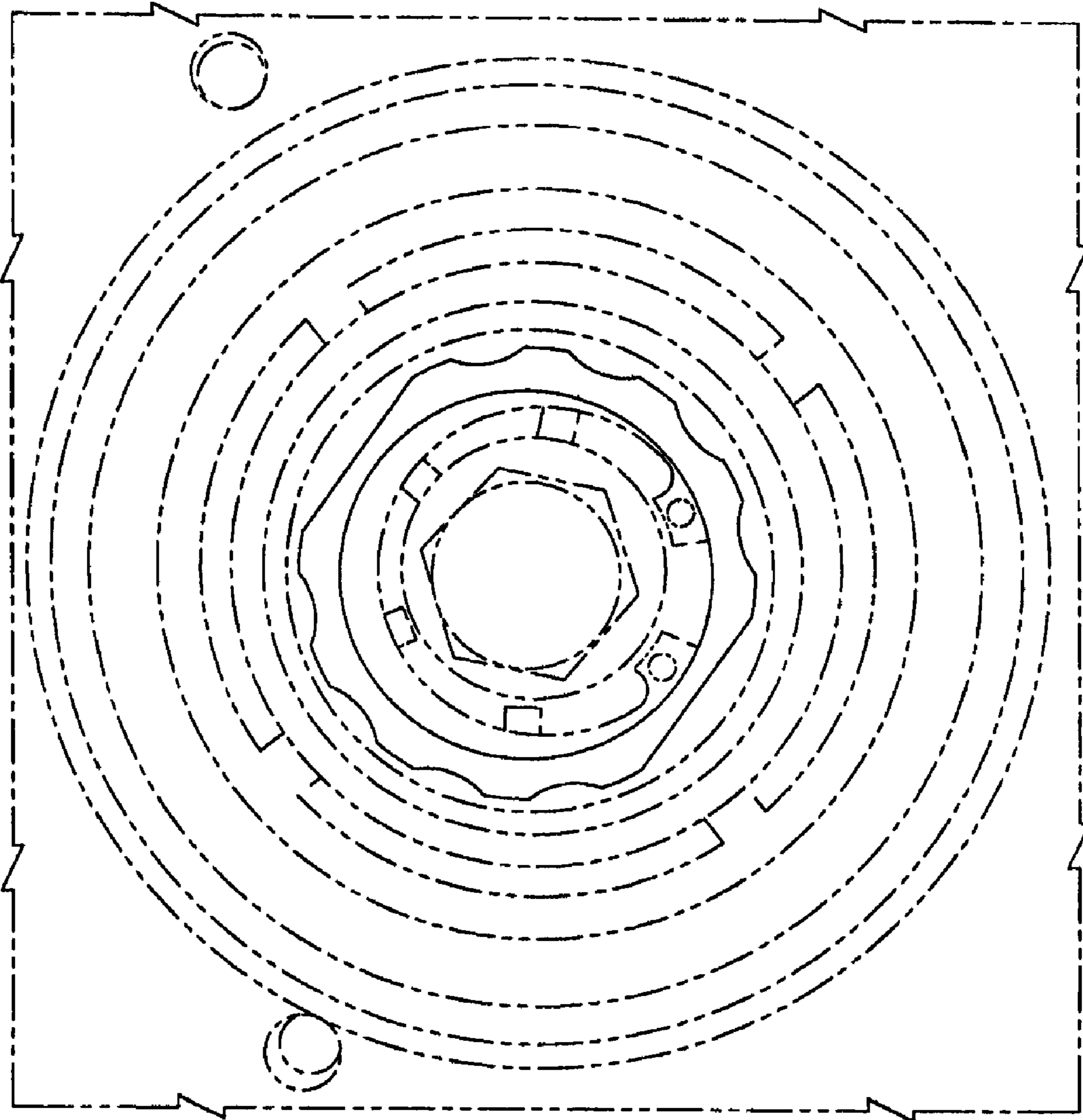

FIG. 3

