



US00D602021S

(12) **United States Design Patent**  
**Noda et al.**

(10) **Patent No.:** **US D602,021 S**  
(45) **Date of Patent:** **\*\* Oct. 13, 2009**

(54) **BIOMETRICS INPUT UNIT**

(75) Inventors: **Hiroyuki Noda**, Kokubunji (JP);  
**Kichiro Kikuchi**, Hitachi (JP); **Hiroto Nakai**, Hitachi (JP); **Hisao Nakayama**, Hitachi (JP)

(73) Assignee: **Hitachi Information & Control Solutions, Ltd.**, Ibaraki-ken (JP)

(\*\*) Term: **14 Years**

(21) Appl. No.: **29/309,977**

(22) Filed: **Nov. 25, 2008**

(30) **Foreign Application Priority Data**

May 27, 2008 (JP) ..... 2008-013227

(51) **LOC (9) Cl.** ..... **14-02**

(52) **U.S. Cl.** ..... **D14/383**

(58) **Field of Classification Search** ..... D14/341-346, D14/383-391; D18/4.4, 4.6, 6, 7; 382/115, 382/116, 119, 124, 126; 356/71; 235/382, 235/382.5; 340/5.52; 713/186; D10/81  
See application file for complete search history.

(56) **References Cited**

**U.S. PATENT DOCUMENTS**

4,857,916 A \* 8/1989 Bellin ..... 340/5.52  
D389,817 S \* 1/1998 Umetsu ..... D14/384  
5,987,155 A \* 11/1999 Dunn et al. .... 382/116

6,041,134 A \* 3/2000 Merjanian ..... 382/126  
D425,881 S \* 5/2000 Borza ..... D14/384  
6,263,090 B1 \* 7/2001 Scott et al. .... 382/124  
D456,408 S \* 4/2002 Common ..... D14/391  
D478,905 S \* 8/2003 Byrne et al. .... D14/384  
D483,762 S \* 12/2003 Berr et al. .... D14/383  
D516,068 S \* 2/2006 Walter ..... D14/383  
D542,291 S \* 5/2007 Kang et al. .... D14/384  
D560,219 S \* 1/2008 Yamakawa et al. .... D14/385  
2002/0174345 A1 \* 11/2002 Patel ..... 713/186

\* cited by examiner

*Primary Examiner*—Freda S Nunn

(74) *Attorney, Agent, or Firm*—Antonelli, Terry, Stout & Kraus, LLP.

(57) **CLAIM**

We claim the ornamental design for biometrics input unit, as shown.

**DESCRIPTION**

FIG. 1 is a front, top and right side perspective view of biometrics input unit showing our new design;

FIG. 2 is a front elevational view thereof;

FIG. 3 is a rear elevational view thereof;

FIG. 4 is a left side elevational view thereof;

FIG. 5 is a right side elevational view thereof;

FIG. 6 is a top plan view thereof; and,

FIG. 7 is a bottom plan view thereof.

**1 Claim, 7 Drawing Sheets**

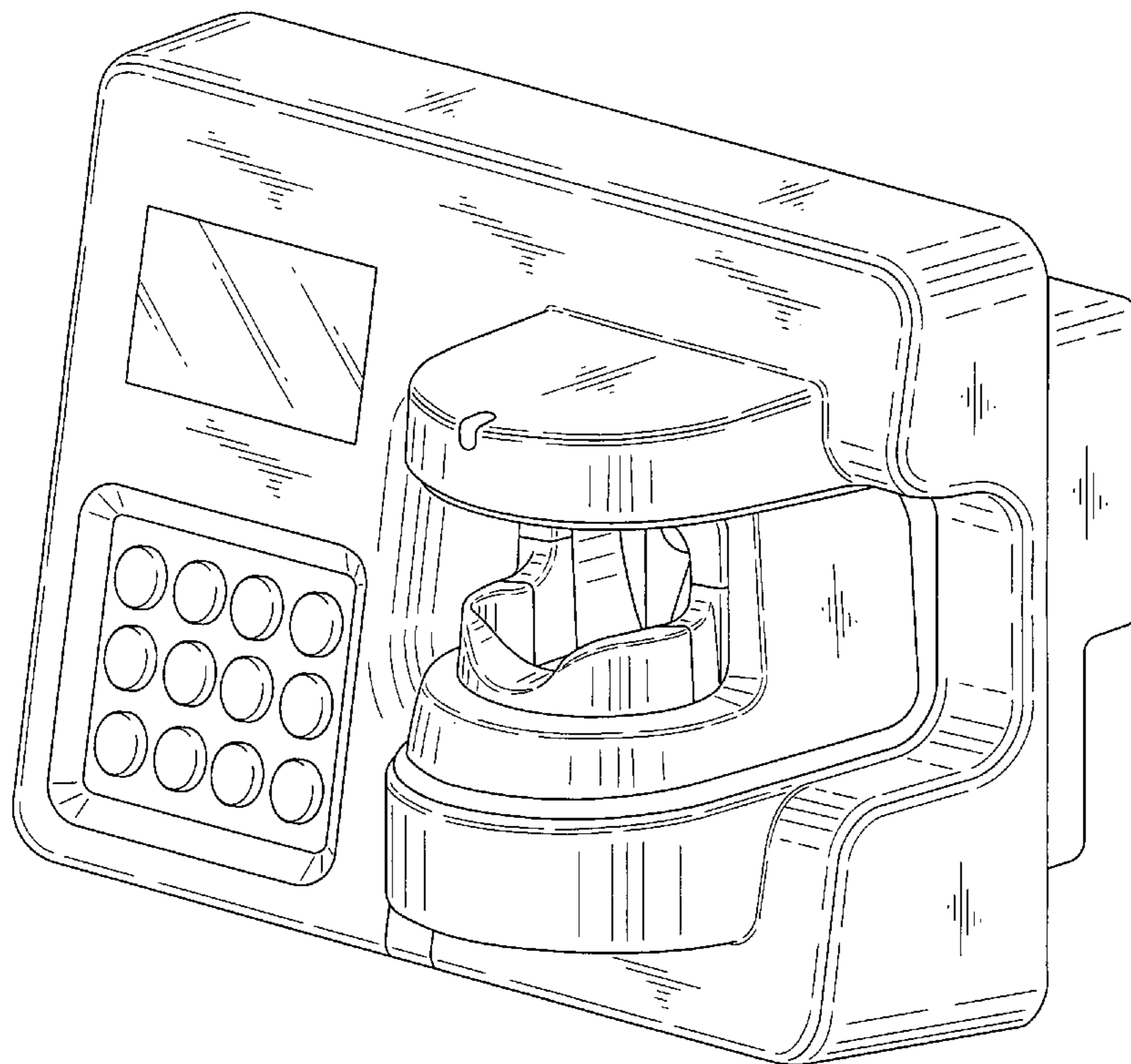

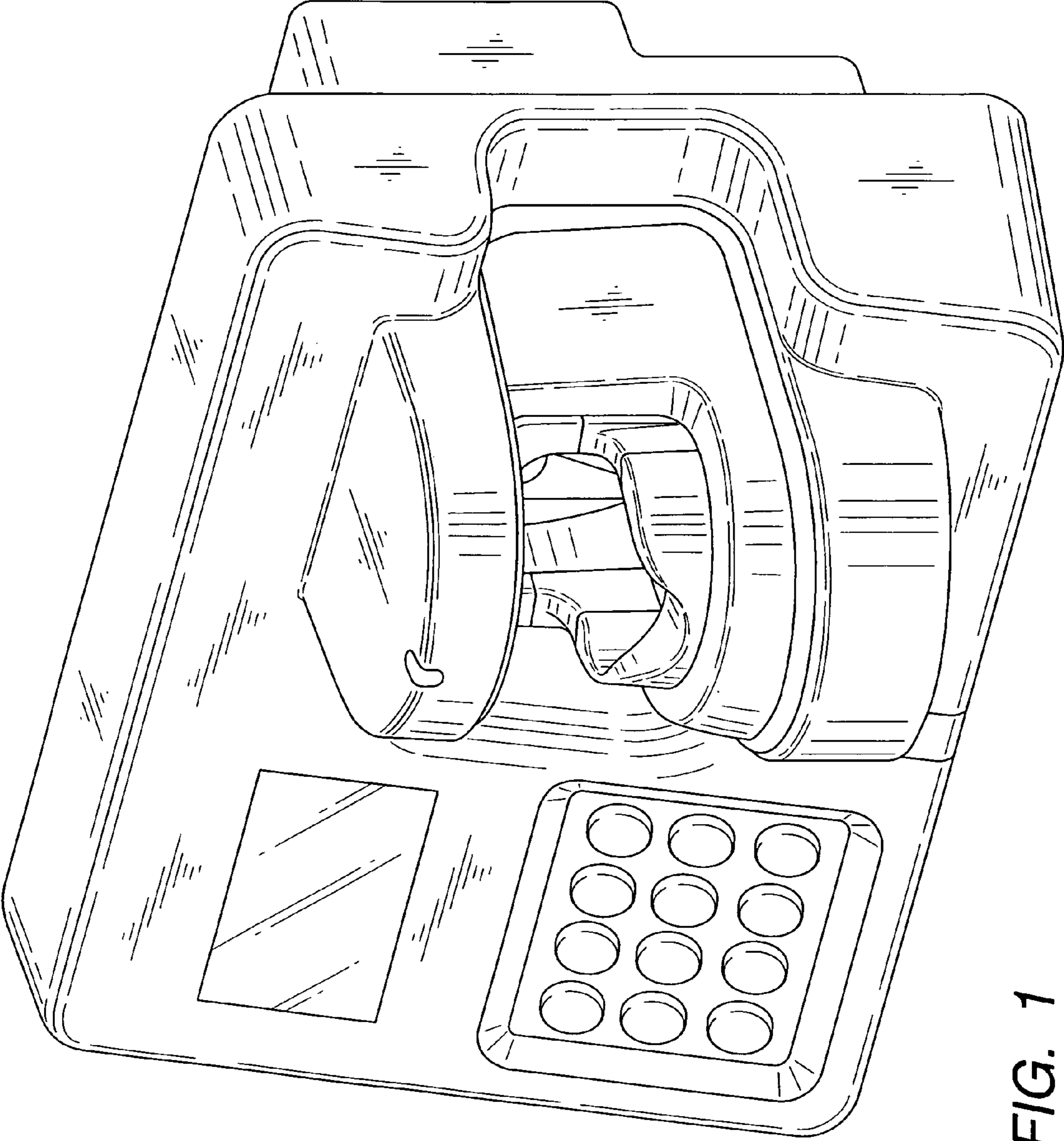

FIG. 1

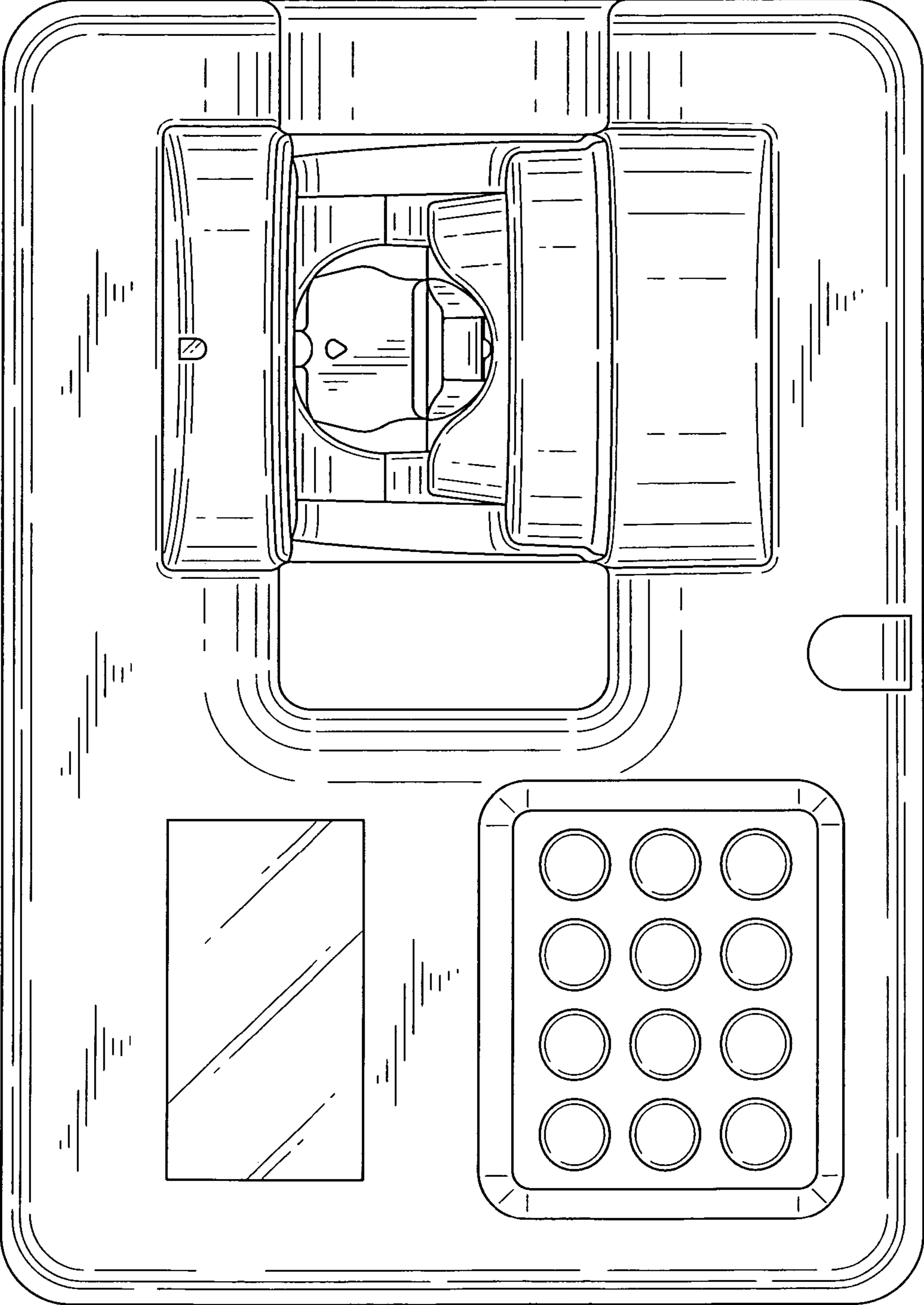

FIG. 2

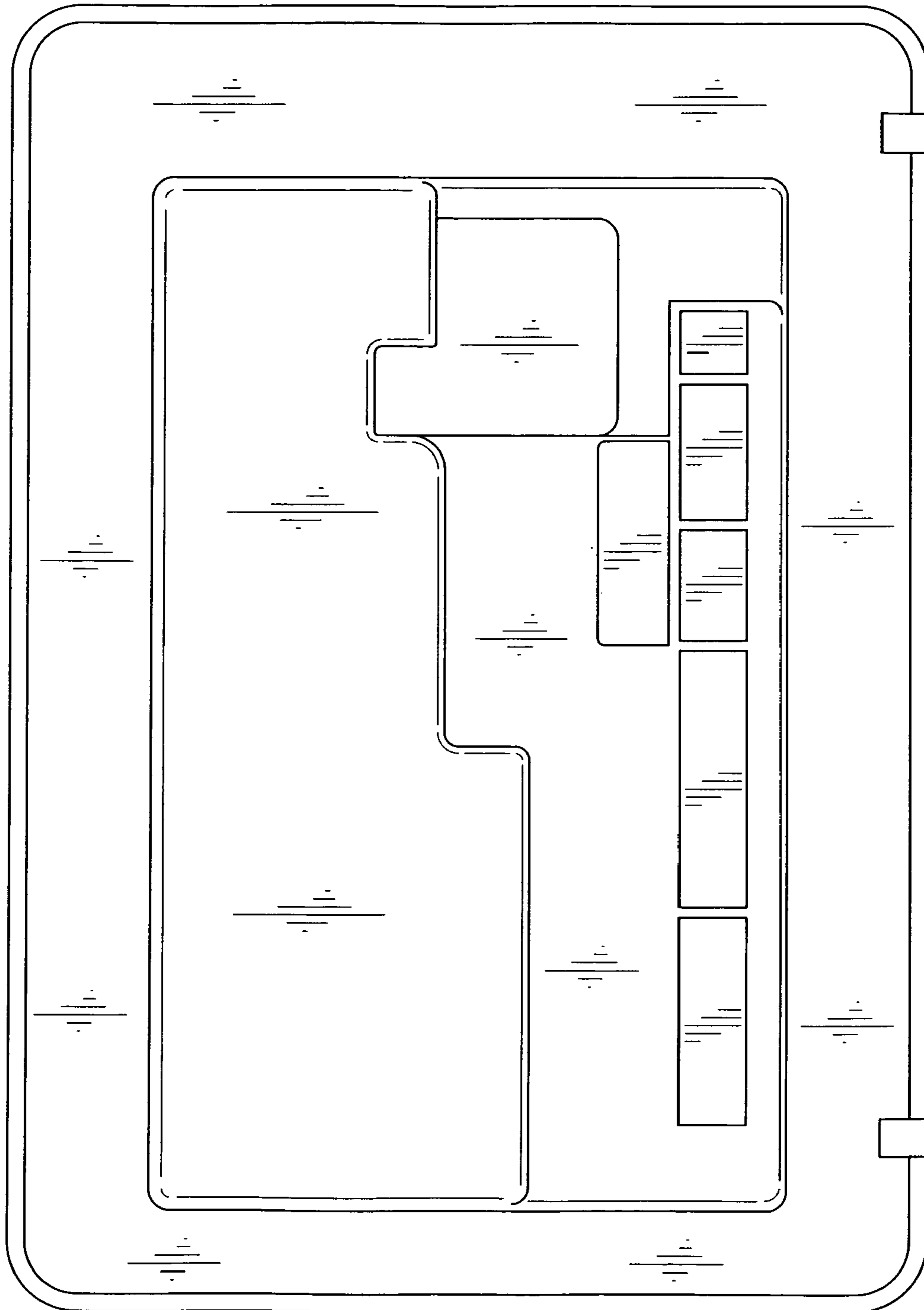
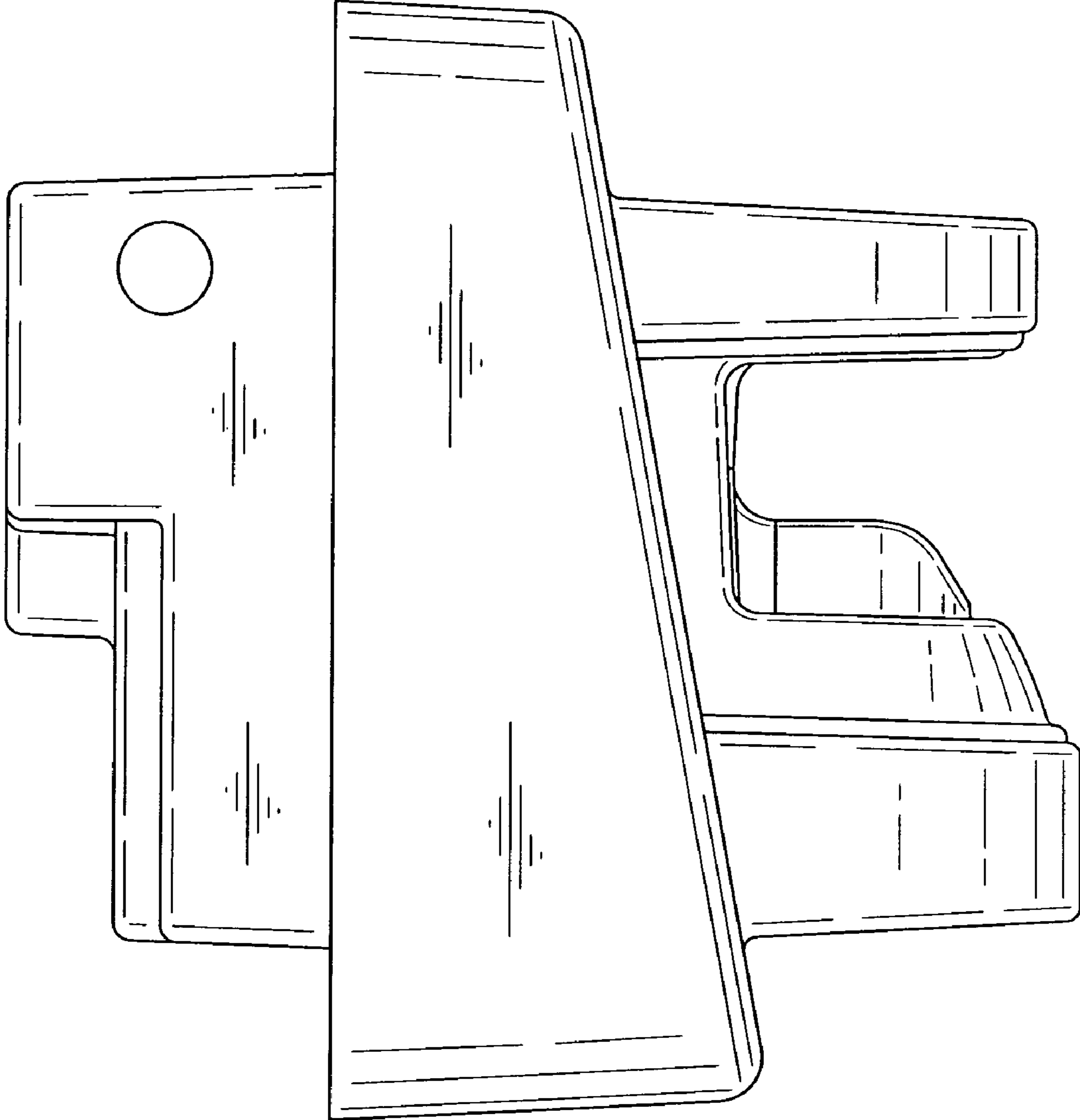
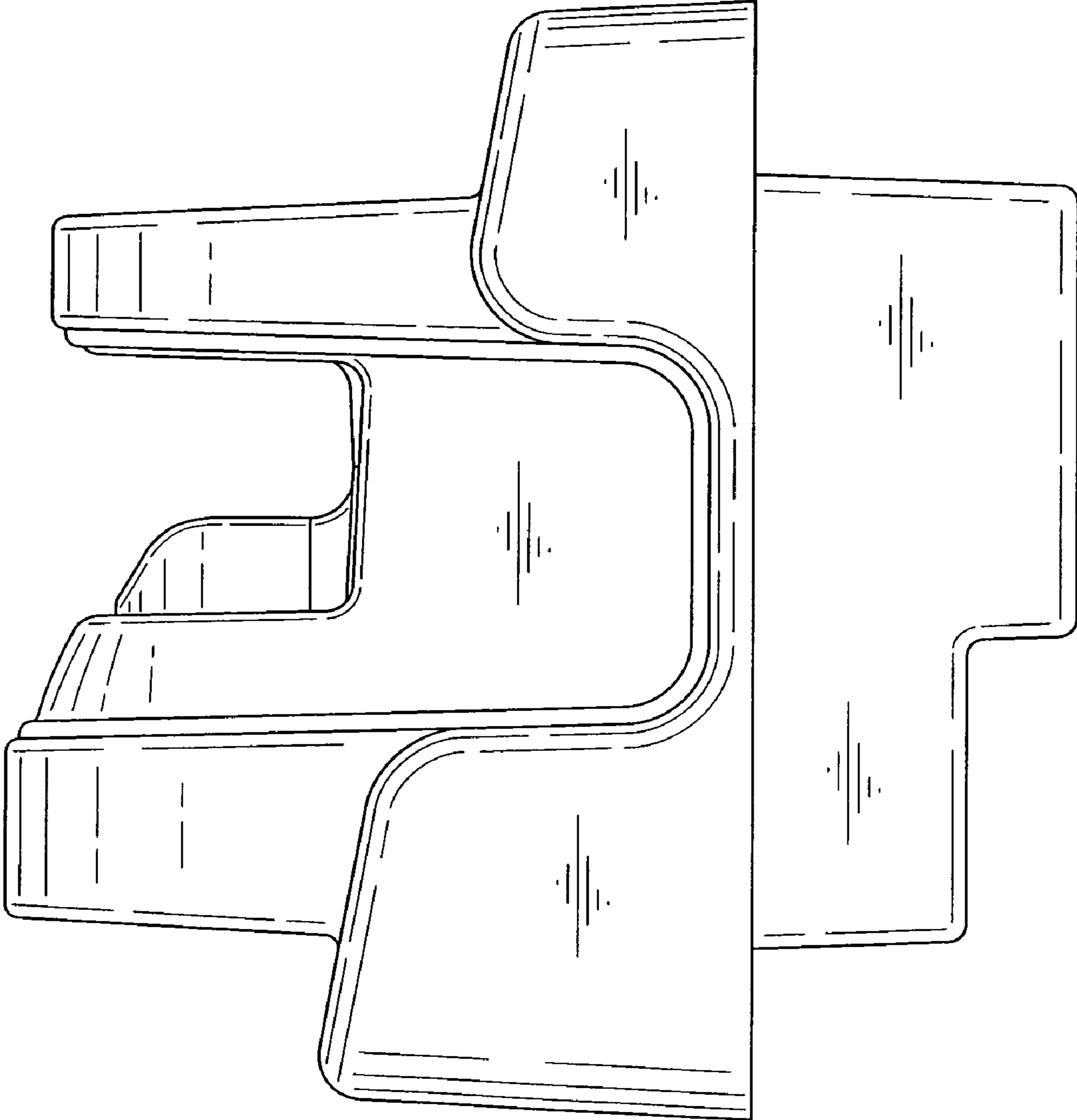

FIG. 3



*FIG. 4*



*FIG. 5*

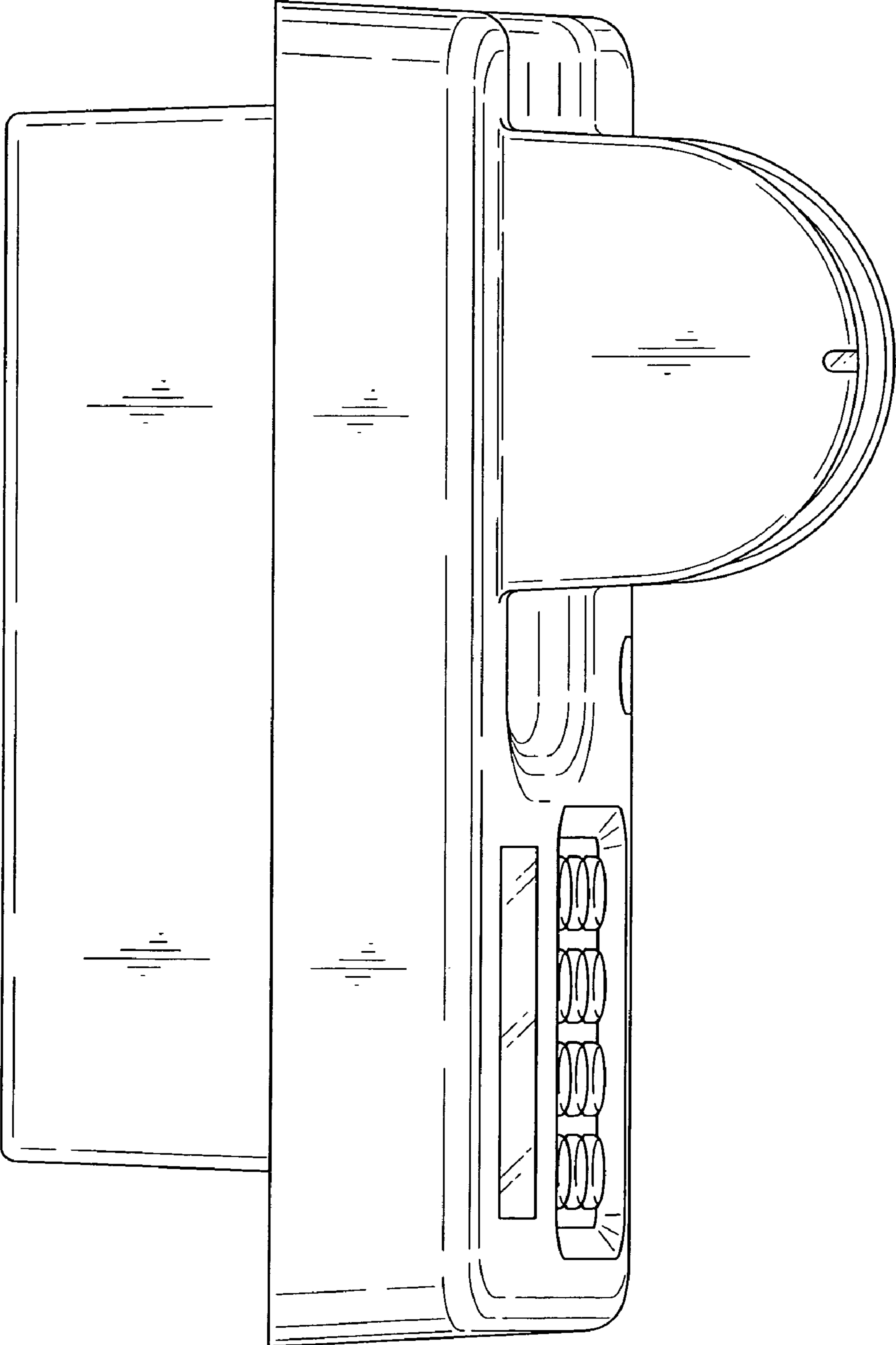

FIG. 6

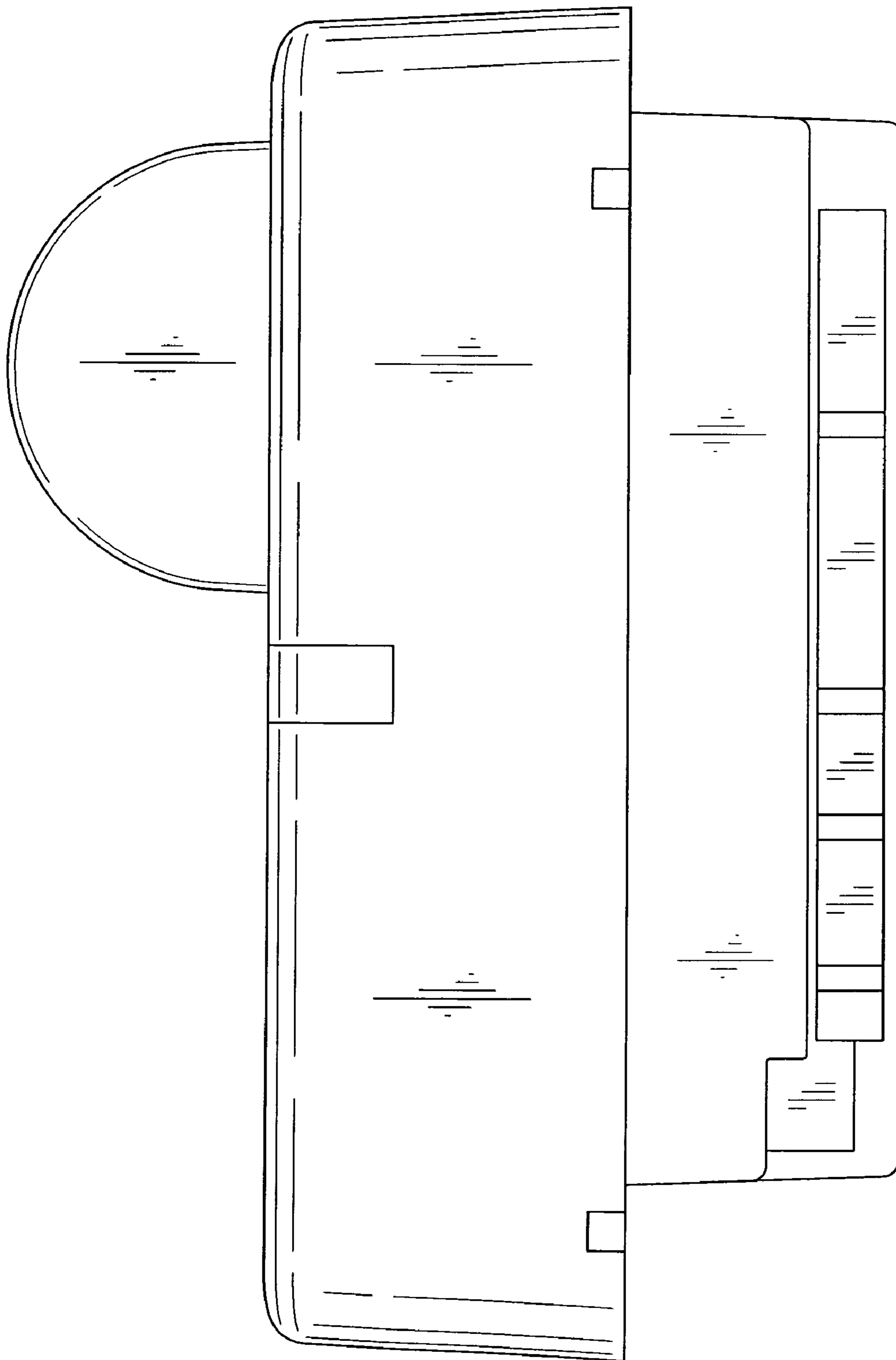

FIG. 7