



US00D601979S

(12) **United States Design Patent**
Sato

(10) **Patent No.:** **US D601,979 S**
(45) **Date of Patent:** **** Oct. 13, 2009**

(54) **PEDESTAL BASE OF A HEAT INSULATING
CYLINDER FOR MANUFACTURING
SEMICONDUCTOR WAFERS**

(75) Inventor: **Izumi Sato**, Oshu (JP)

(73) Assignee: **Tokyo Electron Limited**, Tokyo (JP)

(**) Term: **14 Years**

(21) Appl. No.: **29/309,697**

(22) Filed: **Sep. 26, 2008**

(30) **Foreign Application Priority Data**

Mar. 28, 2008 (JP) 2008-007859

(51) **LOC (9) Cl.** **13-03**

(52) **U.S. Cl.** **D13/182**

(58) **Field of Classification Search** D13/182;
206/454, 711; 118/728, 729; 211/41.18;
432/241, 253, 258

See application file for complete search history.

(56) **References Cited**

U.S. PATENT DOCUMENTS

5,534,074 A * 7/1996 Koons 118/728
D404,375 S * 1/1999 Shimazu D13/182
6,811,040 B2 * 11/2004 Payne et al. 211/41.18
D570,309 S * 6/2008 Sato et al. D13/182

D574,792 S * 8/2008 Sato D13/182
D579,885 S * 11/2008 Sato D13/182
2002/0092815 A1 * 7/2002 Kim et al. 211/41.18
2005/0145584 A1 * 7/2005 Buckley et al. 211/41.18

* cited by examiner

Primary Examiner—Selina Sikder

(74) *Attorney, Agent, or Firm*—Smith, Gambrell & Russell, LLP

(57) **CLAIM**

The ornamental design for a pedestal base of a heat insulating cylinder for manufacturing semiconductor wafers, as shown and described.

DESCRIPTION

FIG. 1 is a perspective view of the design for a pedestal base of a heat insulating cylinder for manufacturing semiconductor wafers in accordance with the invention;

FIG. 2 is a front view thereof;

FIG. 3 is a rear view thereof;

FIG. 4 is a left side view thereof;

FIG. 5 is a right side view thereof;

FIG. 6 is a plan view thereof;

FIG. 7 is a bottom view thereof; and,

FIG. 8 is a sectional view along line 8—8 of FIG. 6.

1 Claim, 8 Drawing Sheets

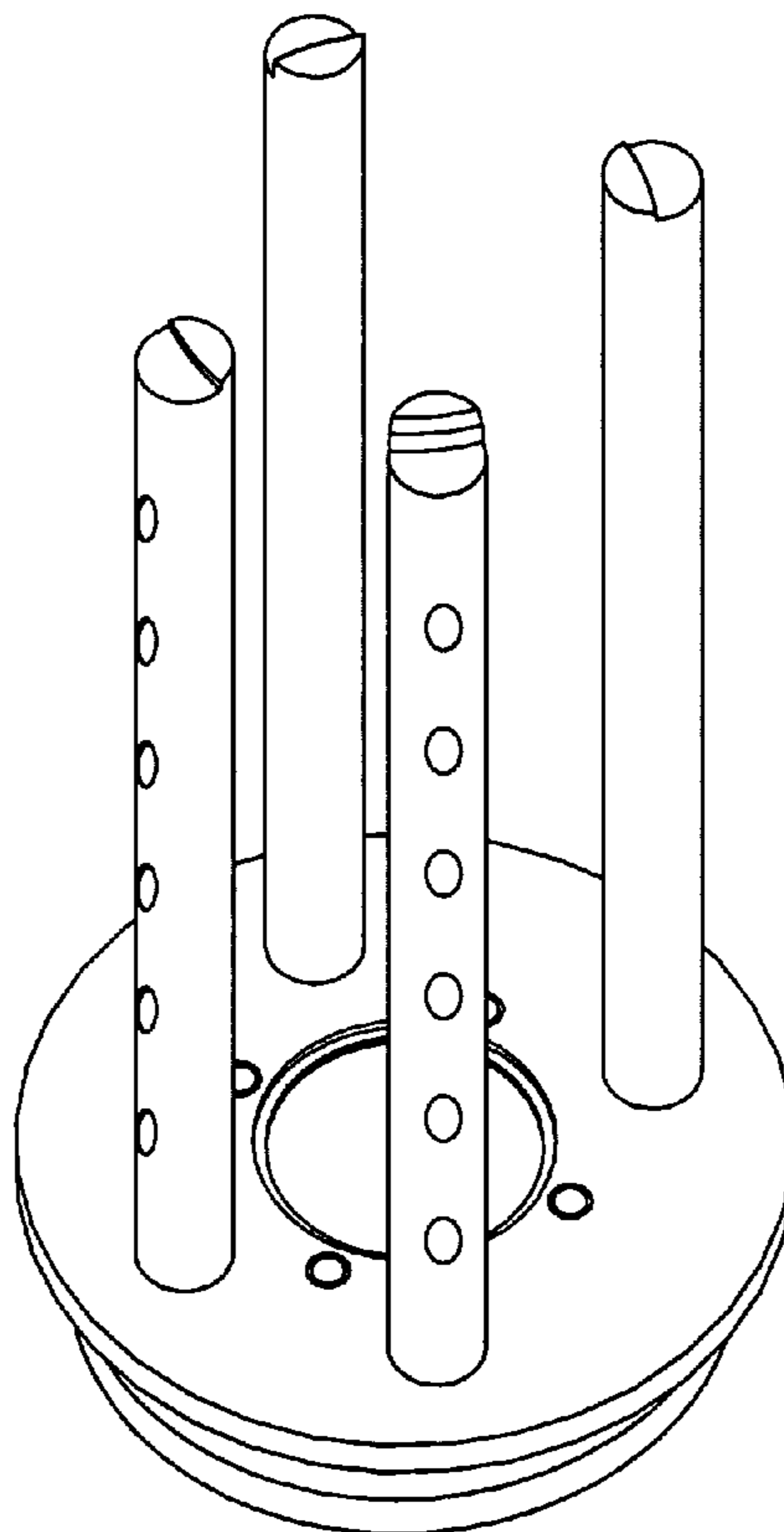

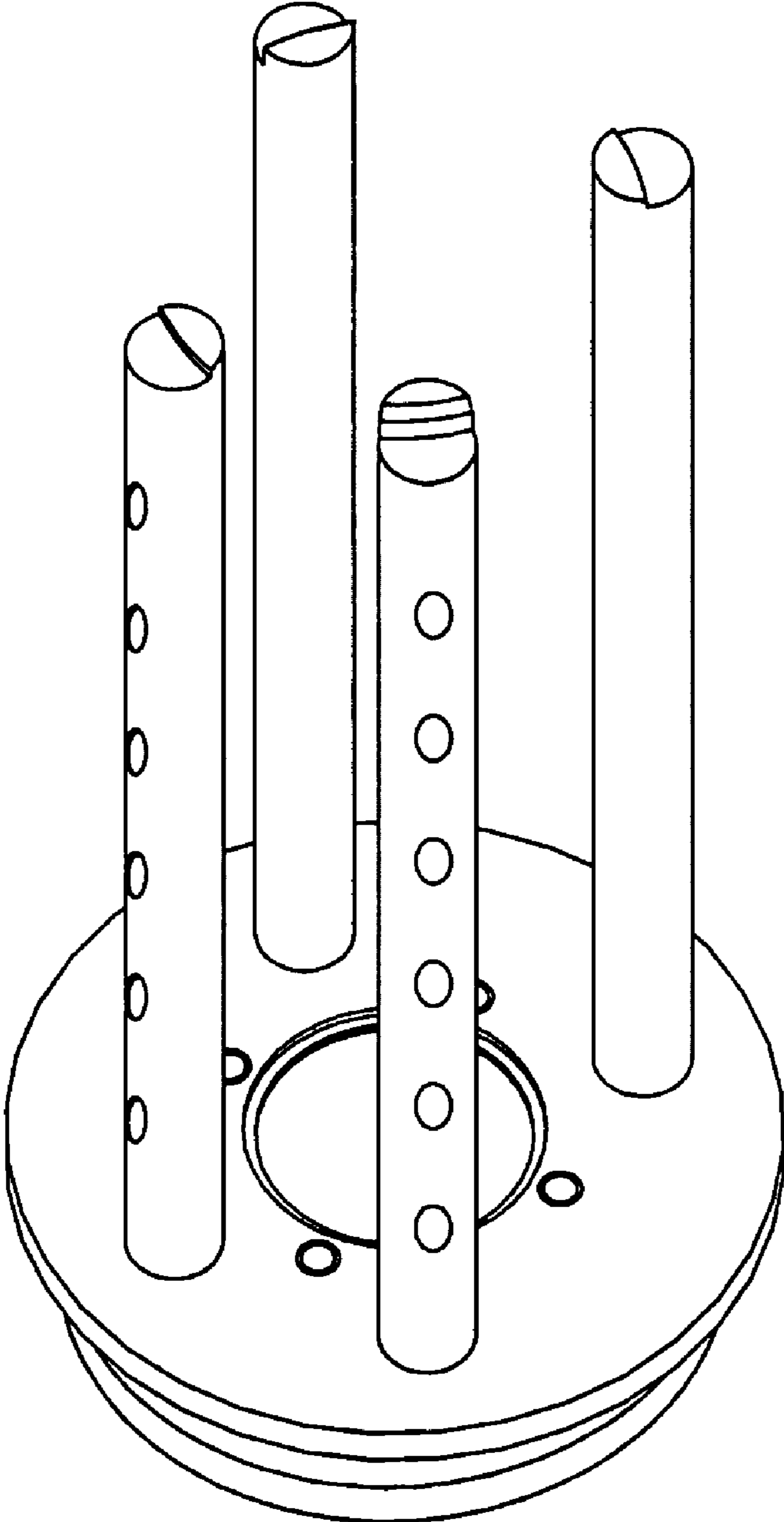

FIG. 1



FIG. 2

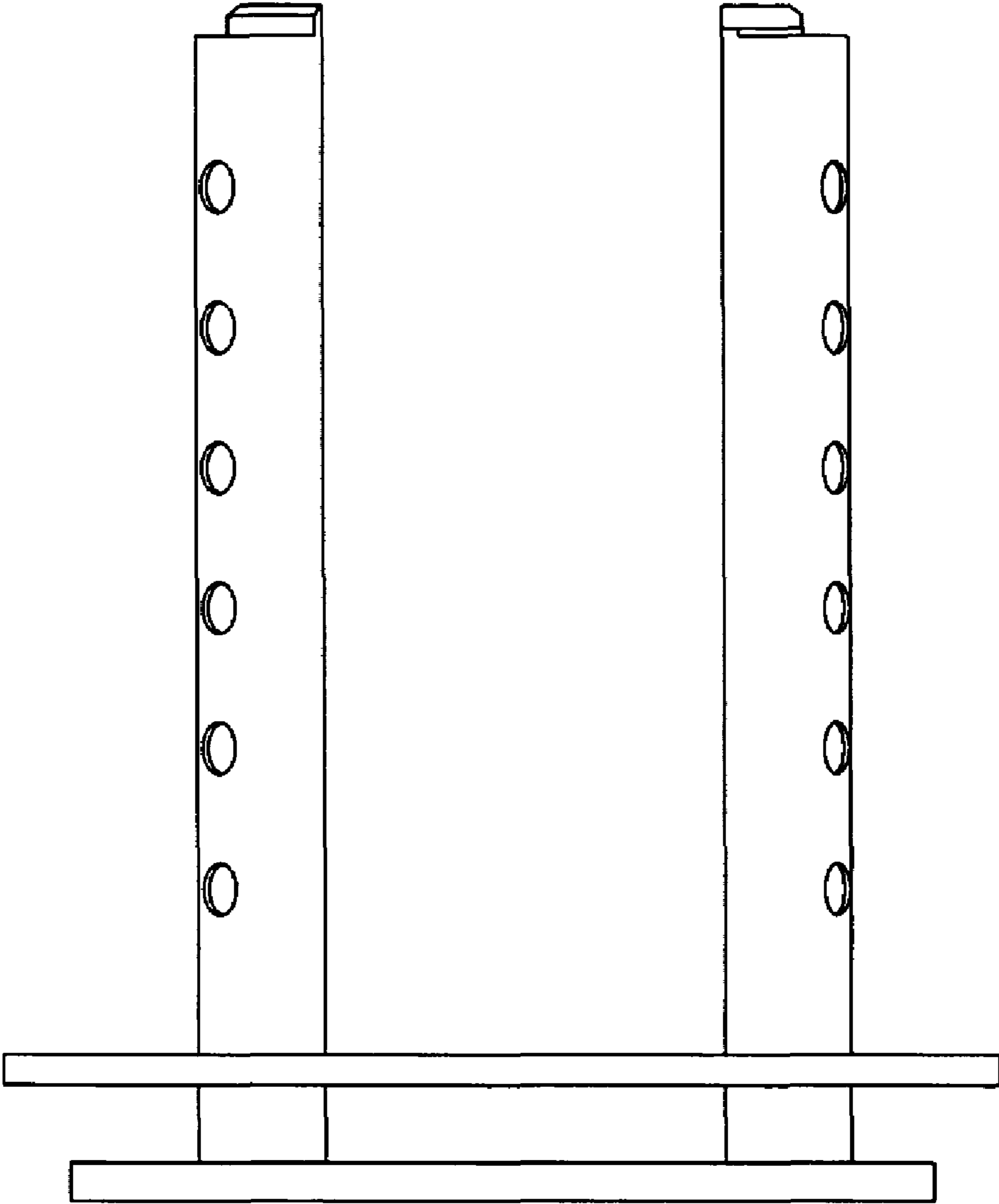

FIG. 3

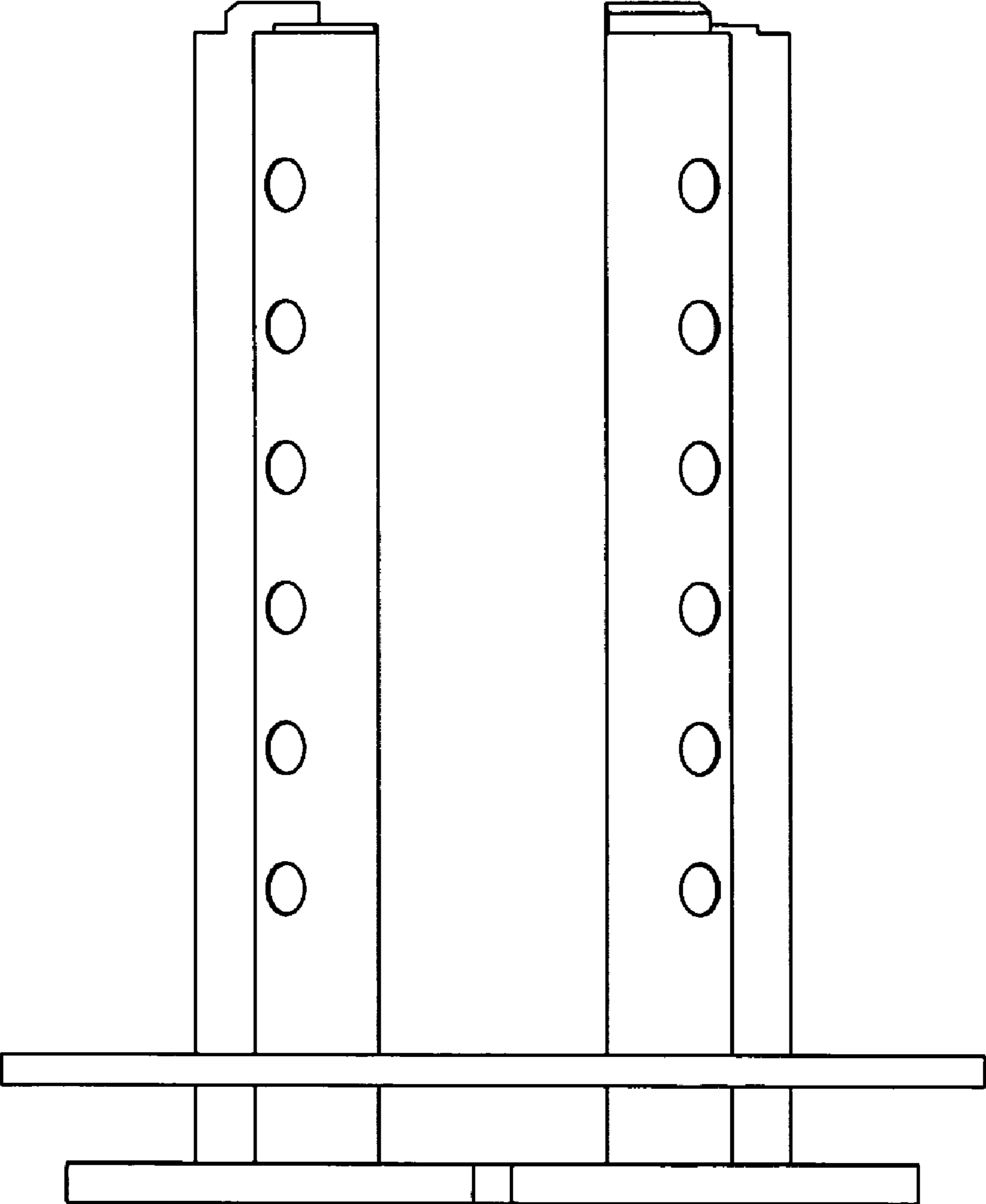

FIG. 4

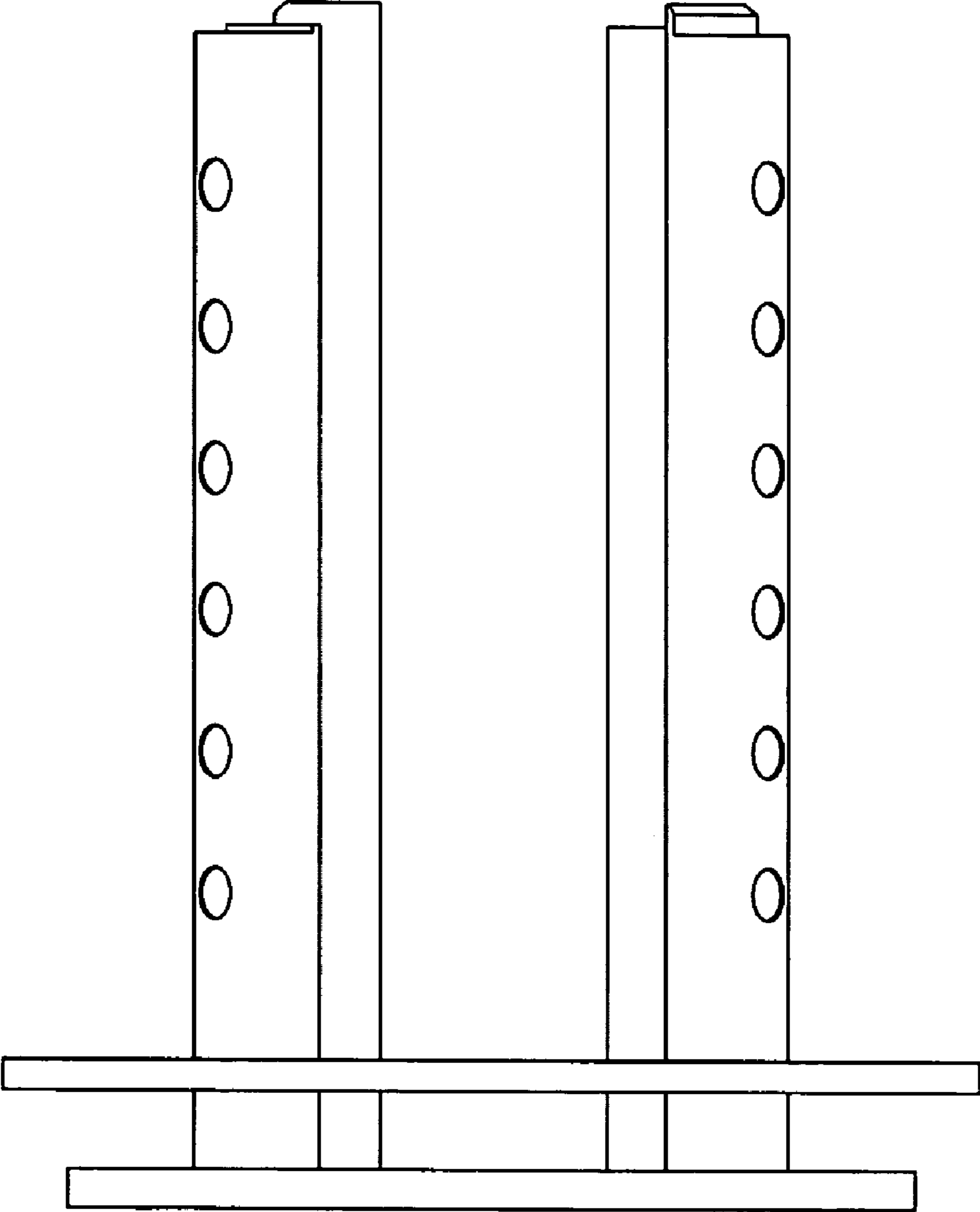

FIG. 5

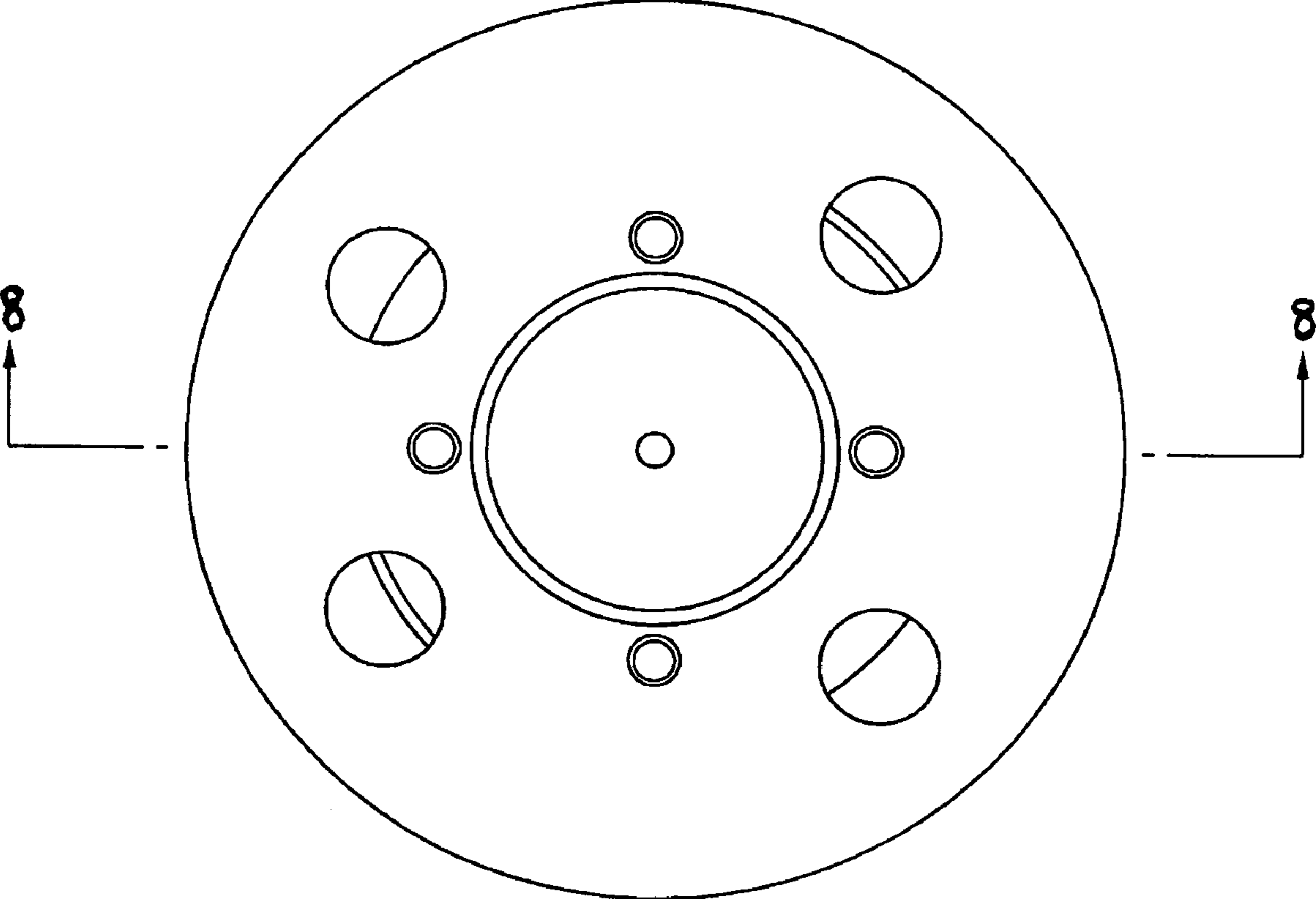

FIG. 6

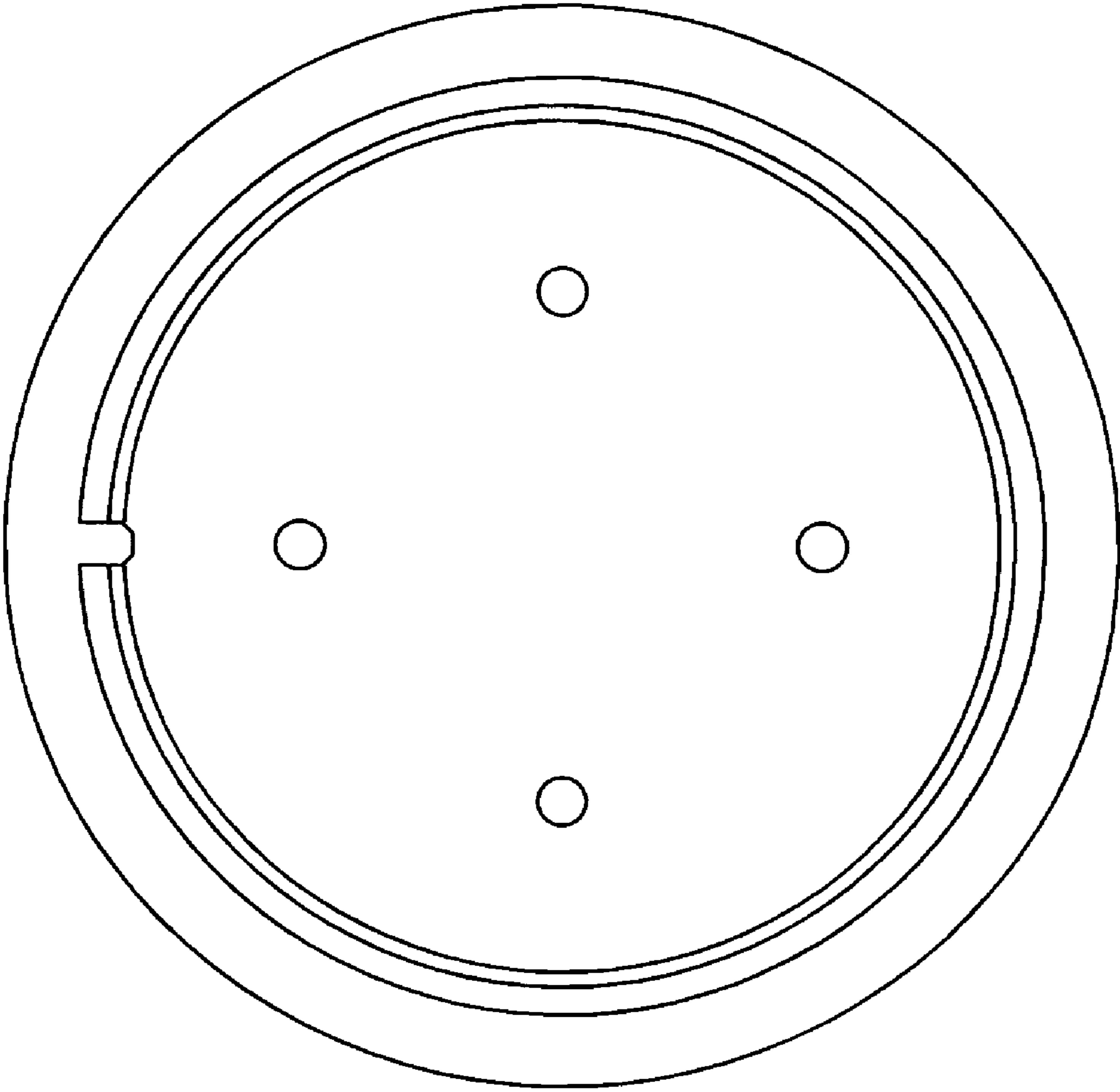

FIG. 7

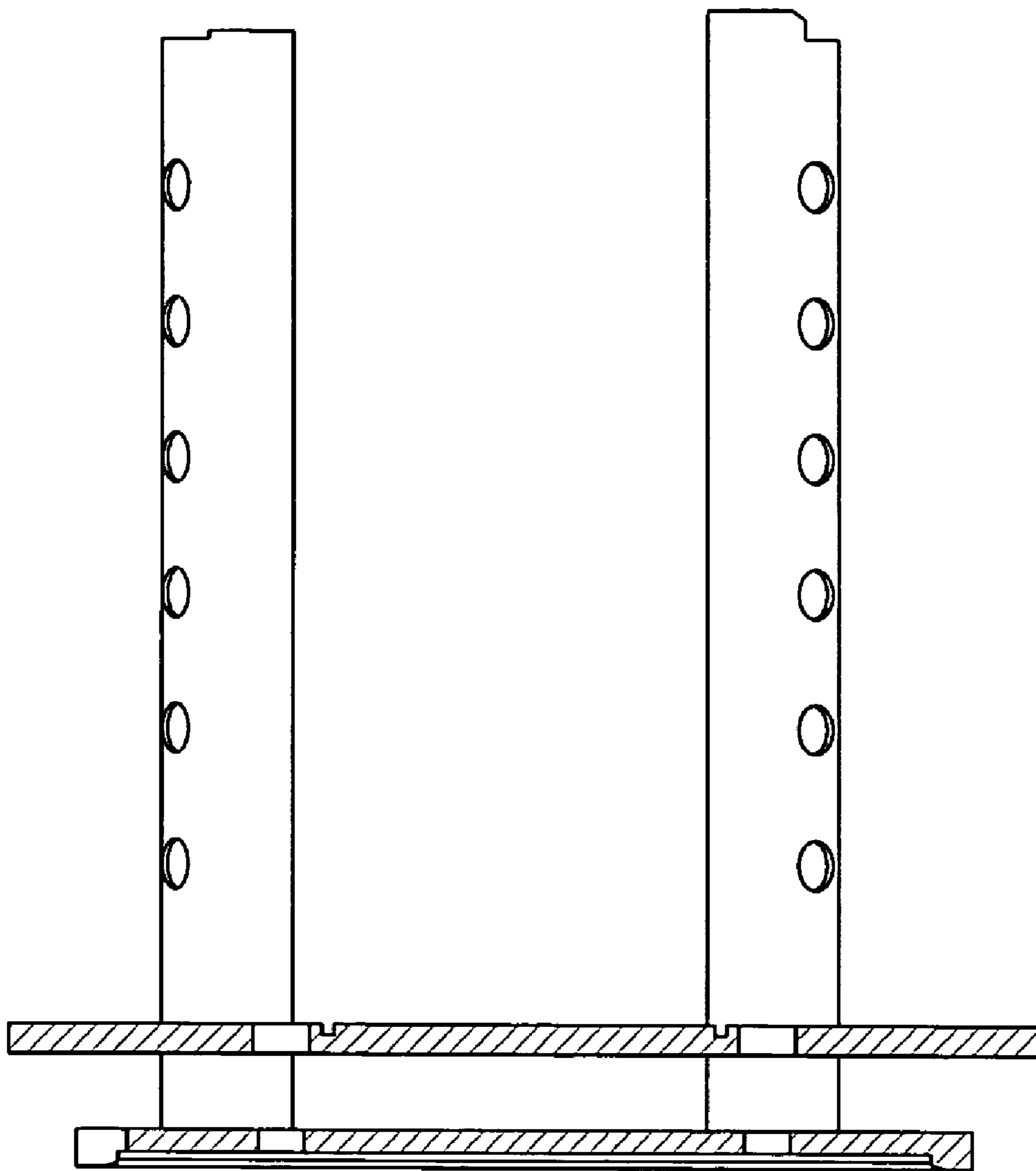

FIG. 8