



US00D601932S

(12) **United States Design Patent**
Rosen et al.

(10) **Patent No.:** **US D601,932 S**
(45) **Date of Patent:** **** Oct. 13, 2009**

(54) **DECORATIVE CROWN FOR A TRUCK**

(75) Inventors: **David B. Rosen**, Flower Mound, TX (US); **Troy R. McCuller**, Corinth, TX (US); **Louis D. Heilaneh**, Lewisville, TX (US)

(73) Assignee: **PACCAR Inc**, Bellevue, WA (US)

(**) Term: **14 Years**

(21) Appl. No.: **29/295,391**

(22) Filed: **Sep. 27, 2007**

(51) **LOC (9) Cl.** **12-16**

(52) **U.S. Cl.** **D12/163**

(58) **Field of Classification Search** D12/93,
D12/96, 97, 163, 173; 180/68.1, 68.6, 69.1,
180/89.1, 89.12; 296/190, 193.1, 194

See application file for complete search history.

(56) **References Cited**

U.S. PATENT DOCUMENTS

D307,731 S	5/1990	Kerney	
D308,032 S	5/1990	Kerney	
D312,805 S	12/1990	Marlowe	
D313,784 S *	1/1991	Marlow et al.	D12/163
D389,108 S *	1/1998	Norwood et al.	D12/163
D412,874 S *	8/1999	Meryman et al.	D12/163
D425,835 S	5/2000	Cook	
D447,099 S *	8/2001	Tirey et al.	D12/163
D484,077 S	12/2003	Conway	
D497,581 S	10/2004	Conway	
D502,897 S *	3/2005	Delashaw et al.	D12/163
D504,850 S	5/2005	Gunter	
D551,133 S *	9/2007	Angelo et al.	D12/163

OTHER PUBLICATIONS

Canadian Kenworth Truck, Mississauga, Ontario, Canada, "Construction Trucks," Jul. 1990, 16-page brochure.

Kenworth Truck Company, Kirkland, Washington, "T600A," 1985, 10-page brochure.

Kenworth Truck Company, Kirkland, Washington, "AeroCab," 1993, 6-page brochure.

Kenworth Truck Company, Kirkland, Washington, "Studio Sleeper," 1993, 5-page brochure.

Kenworth Truck Company, Kirkland, Washington, "W900L AeroCab," 1994, 2-page brochure.

Kenworth Truck Company, Kirkland, Washington, "T600," 1996, 7-page brochure.

Kenworth Truck Company, Kirkland, Washington, "T800," 1996, 7-page brochure.

Kenworth Truck Company, Kirkland, Washington, "W900," 1996, 7-page brochure.

Kenworth Truck Company, Kirkland, Washington, "T300," 1997, 5-page brochure.

(Continued)

Primary Examiner—Robert M Spear

Assistant Examiner—Barbara B Lohr

(74) *Attorney, Agent, or Firm*—Christensen O'Connor Johnson Kindness PLLC

(57) **CLAIM**

The ornamental design for a decorative crown for a truck, as shown and described.

DESCRIPTION

FIG. 1 is a front perspective view of a decorative crown for a truck showing a first embodiment of our new design;

FIG. 2 is a top plan view thereof;

FIG. 3 is a bottom plan view thereof;

FIG. 4 is a front elevational view thereof;

FIG. 5 is a first side elevational view thereof, the second side elevation being a mirror image thereof;

FIG. 6 is a front perspective view of a decorative crown for a truck showing a second embodiment of our new design;

FIG. 7 is a top plan view thereof;

FIG. 8 is a bottom plan view thereof;

FIG. 9 is a front elevational view thereof; and,

FIG. 10 is a first side elevational view thereof, the second side elevation being a mirror image thereof.

The rear of the decorative crown for a truck is unornamented.

1 Claim, 4 Drawing Sheets

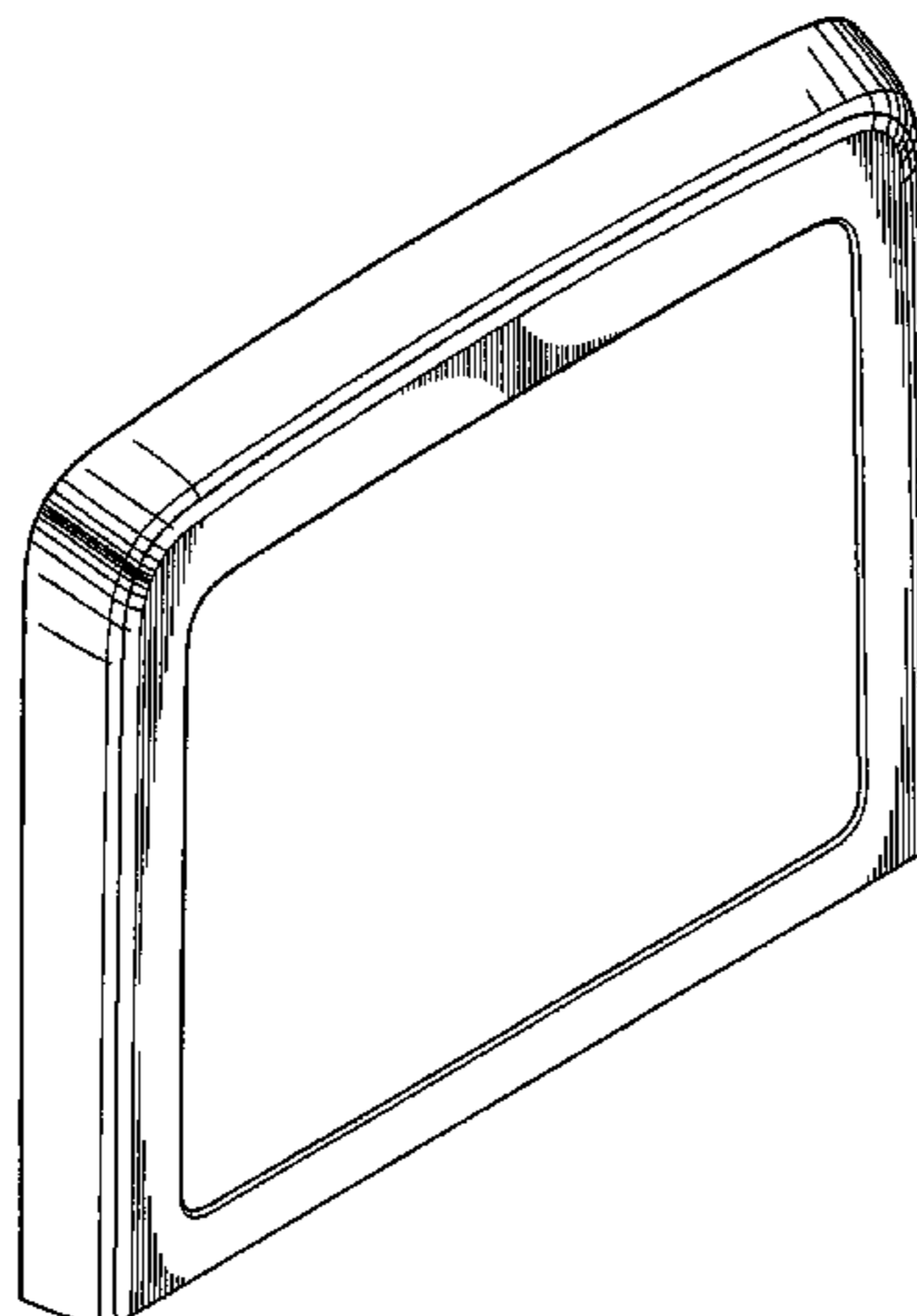

OTHER PUBLICATIONS

- Kenworth Truck Company, Kirkland, Washington, "T2000," 1999, 20-page brochure.
- Peterbilt Motors Company; Denton, Texas, "Model 357," 1994, 3-page brochure.
- Peterbilt Motors Company, Denton Texas, "Unibilt™ Cab Sleeper System," Aug. 1994, 6-page brochure.
- Peterbilt Motors Company, Denton, Texas, "Model 377A/E," Jan. 1995, 6-page brochure.
- Peterbilt Motors Company, Denton, Texas, "Model 379," Mar. 1996, 5-page brochure.
- Peterbilt Motors Company, Denton, Texas, "Model 320," May 1996, 2-page brochure.
- Peterbilt Motors Company, Denton, Texas, "Model 385," Oct. 1996, 5-page brochure.
- Peterbilt Motors Company, Denton, Texas, "Model 377A/E," Aug. 1997, 2-page brochure.
- Peterbilt Motors Company, Denton, Texas, "Class Pays," Sep. 1997, 10-page brochure.
- Peterbilt Motors Company, Denton, Texas, "Model 330," Oct. 1997, 3-page brochure.
- Peterbilt Motors Company, Denton, Texas, "Model 378," Mar. 1998, 3-page brochure.
- Peterbilt Motors Company, Denton, Texas, "Class Pays," Nov. 1998, 10-page brochure.
- Peterbilt Motors Company, Denton, Texas, "Class Pays, Ergonomic Dash," Mar. 2000, 2-page brochure.
- Peterbilt Motors Company, Denton, Texas, "Class Pays, Medium Duty," Sep. 2000 12-page brochure.
- Peterbilt Motors Company, Denton, Texas, "Model 357, New Sloped Hood," May 2002, 2-page brochure.
- Peterbilt Motors Company, Denton, Texas, "Model 387," Oct. 2002, 2-page brochure.
- Peterbilt Motors Company, Denton, Texas, "Class Pays Refuse Trucks," Sep. 2003, 2-page brochure.
- Peterbilt Motors Company, Denton, Texas, "Model 357 Heavy Haul," Mar. 2005, 2-page brochure.
- Peterbilt Motors Company, Denton, Texas, "Model 357-¹¹⁵," Mar. 2005, 2-page brochure.
- Peterbilt Motors Company, Denton, Texas, "Model 379," Apr. 2005, 2-page brochure.
- Peterbilt Motors Company, Denton, Texas, "Class Pays, Platinum Interior," May 2005, 4-page brochure.
- Peterbilt Motors Company, Newark, California, "The Working Class," Sep. 1976, 6-page brochure.
- Peterbilt Motors Company, Newark, California, "Rest with Class," Apr. 1978, 4-page brochure.
- Peterbilt Motors Company, Newark, California, "Model 362," 1985, 8-page brochure.
- Peterbilt Motors Company, Newark, California, "Model 357 Standard Specifications," Sep. 1986, 6-page brochure.
- Peterbilt Motors Company, Newark, California, "Model 375 Standard Specifications," Sep. 1986, 6-page brochure.
- Peterbilt Motors Company, Denton, Texas, "Peterbilt Parts & Accessories" catalog, as early as 2000.
- Peterbilt Motors Company, Newark, California, "Cabovers," as early as 2000, 7-page brochure.

* cited by examiner

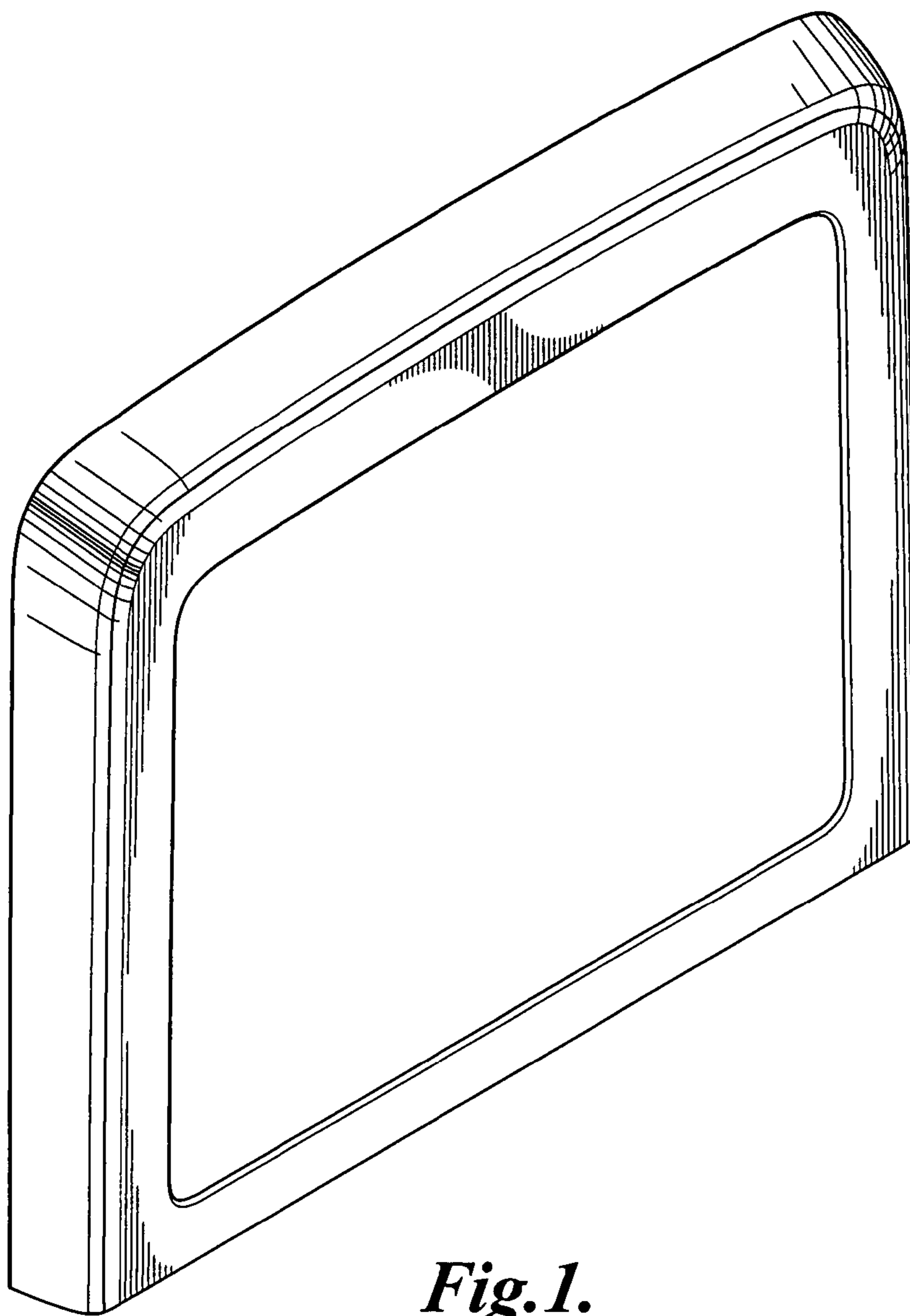

Fig. 1.

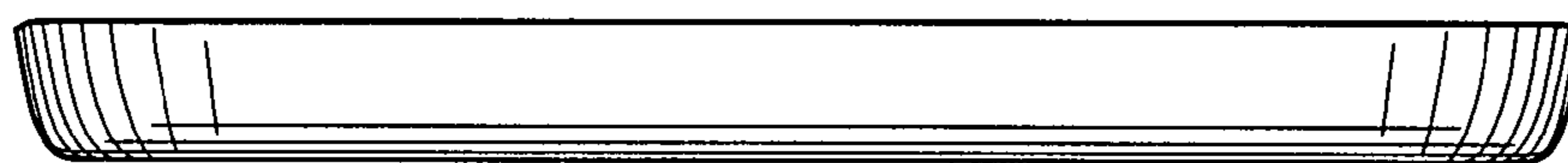

Fig. 2.



Fig. 3.

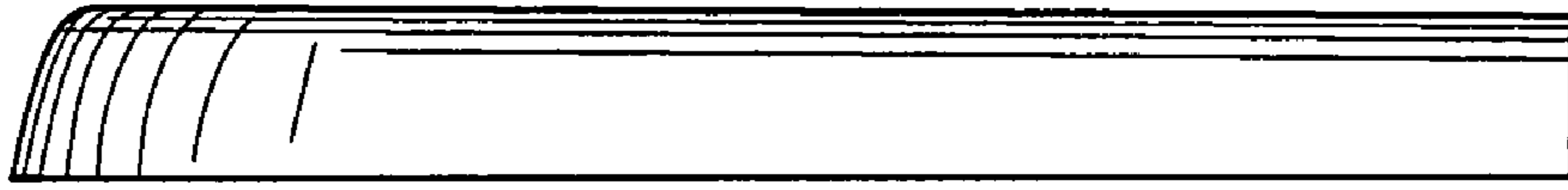

Fig. 5.

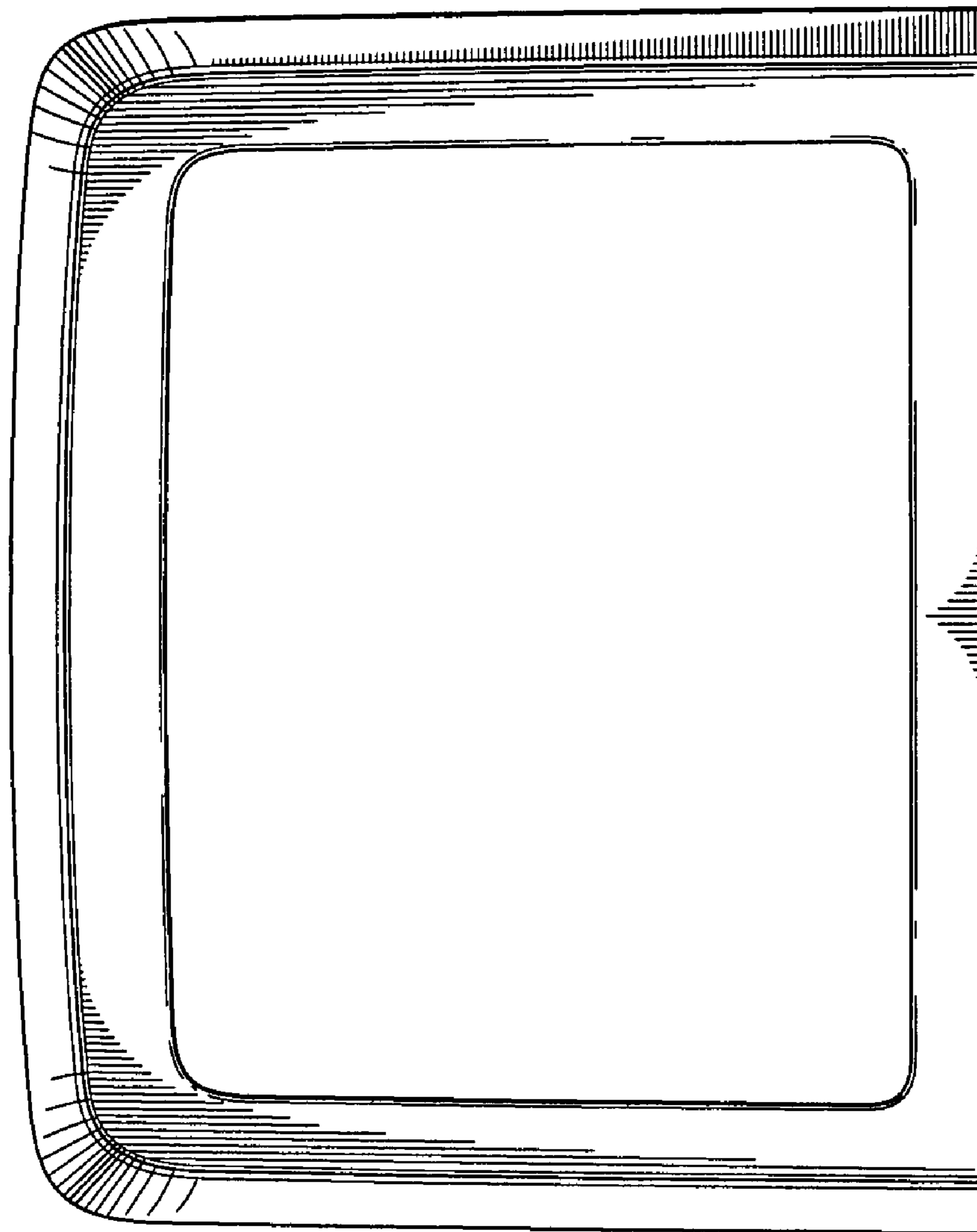

Fig. 4.

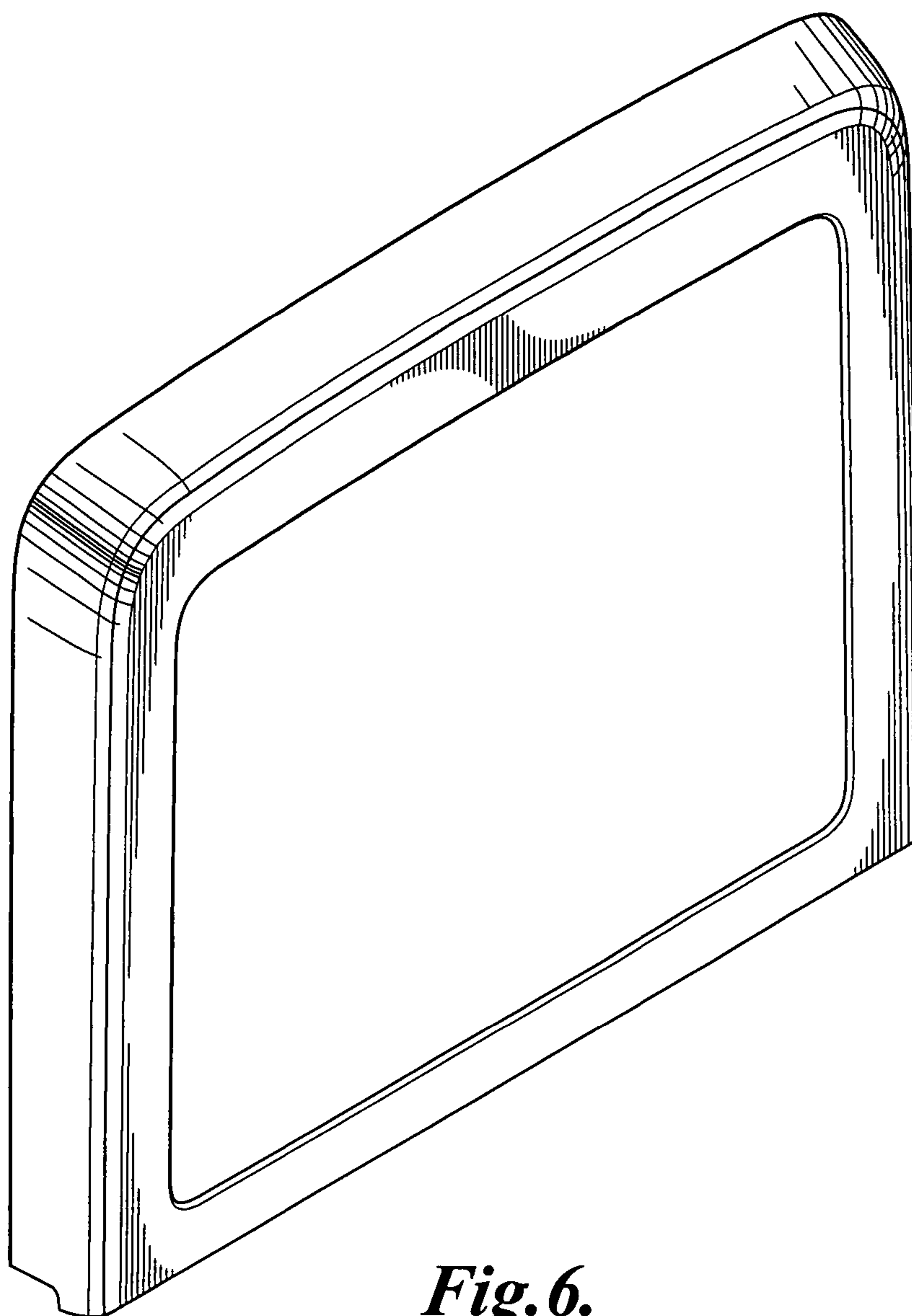

Fig. 6.

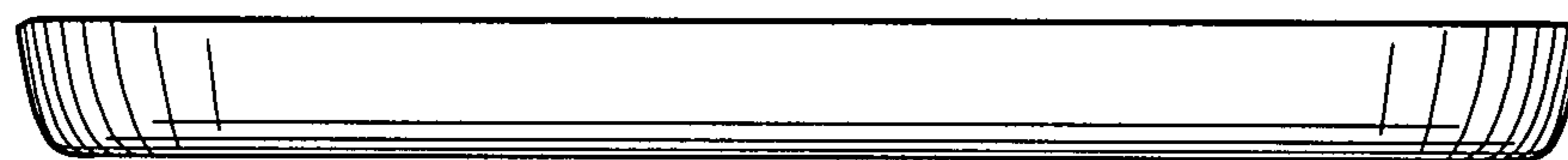

Fig. 7.

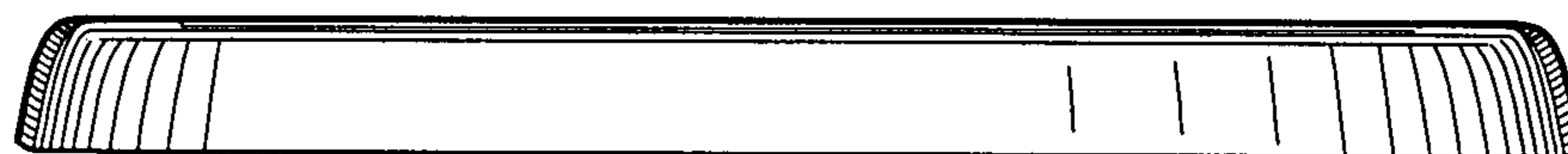

Fig. 8.

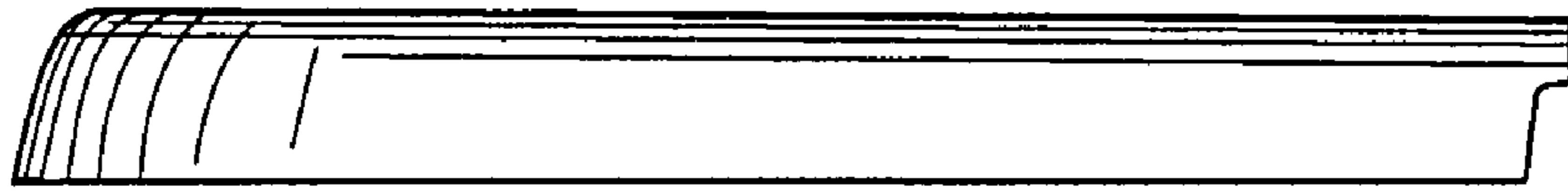

Fig. 10.

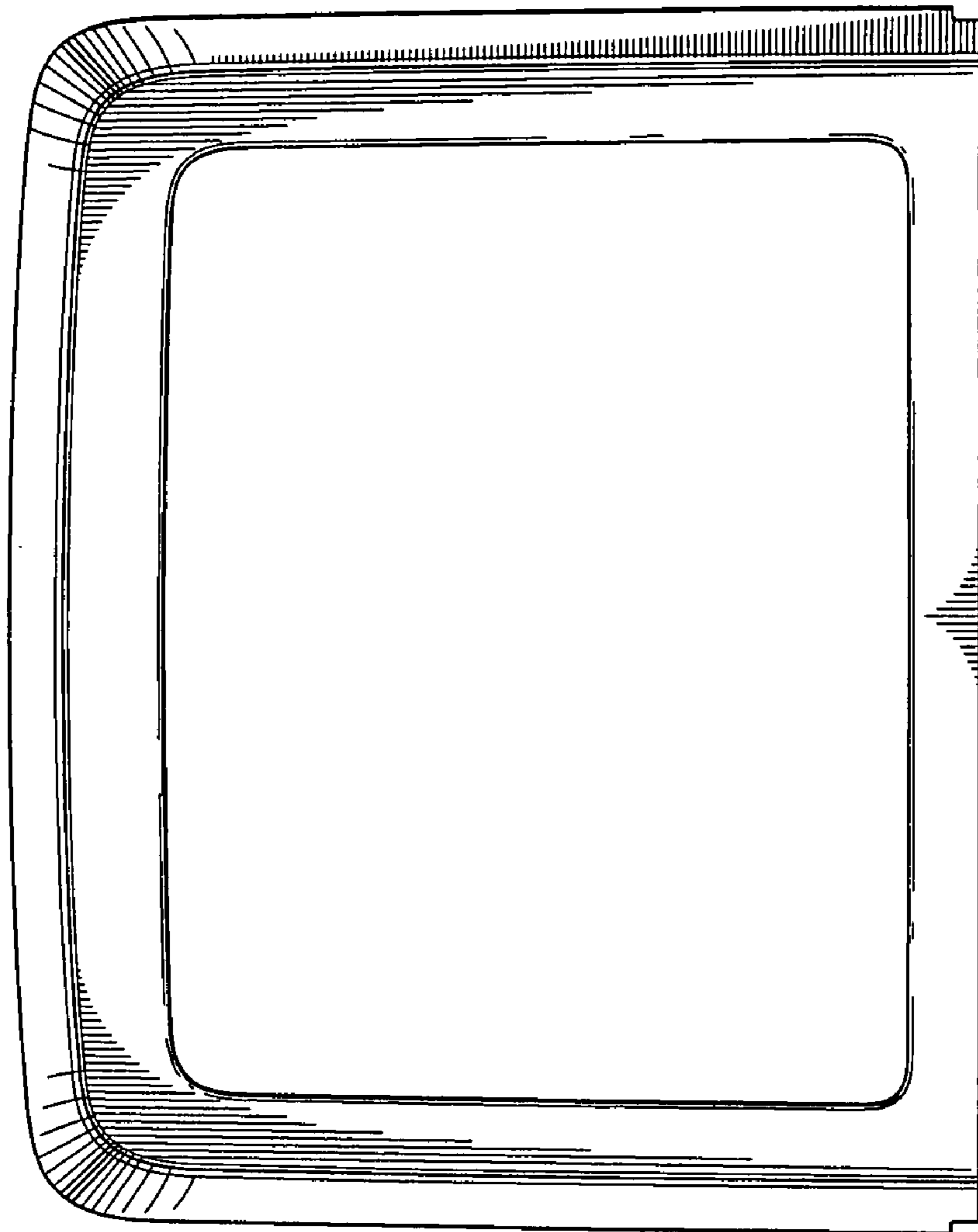

Fig. 9.