



US00D601587S

(12) **United States Design Patent**
Beatty

(10) **Patent No.:** **US D601,587 S**
(45) **Date of Patent:** **** Oct. 6, 2009**

(54) **DRIVESHAFT TUNNEL**

D463,450 S * 9/2002 Beckenbach et al. D15/5
D579,842 S * 11/2008 Ren D12/194

(76) Inventor: **Ernest Dean Beatty**, 3764 Zink Rd.,
Carleton, MI (US) 48117

FOREIGN PATENT DOCUMENTS

FR 2798448 3/2001

(**) Term: **14 Years**

* cited by examiner

(21) Appl. No.: **29/319,740**

Primary Examiner—Lisa P Lichtenstein
(74) *Attorney, Agent, or Firm*—Gifford, Krass, Sprinkle,
Anderson & Citkowski, P.C.

(22) Filed: **Jun. 13, 2008**

(51) **LOC (9) Cl.** **15-01**

(57) **CLAIM**

(52) **U.S. Cl.** **D15/5**

(58) **Field of Classification Search** D15/1,
D15/3, 5, 148; 248/250; 74/609

I claim the ornamental design for a driveshaft tunnel, as
shown and described.

See application file for complete search history.

DESCRIPTION

(56) **References Cited**

FIG. 1 is a perspective side view of a driveshaft tunnel shaped
according to the design;

U.S. PATENT DOCUMENTS

FIG. 2 is a top view of the design;

926,800 A	7/1909	Young	
1,236,768 A	8/1917	Sarmiento	
D59,358 S	10/1921	Kanev	
2,612,763 A *	10/1952	Hansen	464/176
2,775,905 A *	1/1957	Jackson	74/609
3,455,409 A	7/1969	Clark	
3,981,376 A	9/1976	Kluge, Jr.	
D244,020 S	4/1977	Hanson et al.	
D252,576 S	8/1979	Frey	
4,324,533 A	4/1982	Schroeder et al.	
5,193,415 A	3/1993	Massel	
5,711,710 A	1/1998	Brisk	
5,906,347 A	5/1999	Noland	

FIG. 3 is a side view of the design, the opposite side being the
mirror image thereof;

FIG. 4 is an end view of the design;

FIG. 5 is an opposite end view of the design; and,

FIG. 6 is a bottom view of the design.

The broken line showing of portions of the driveshaft tunnel
is included for the purpose of illustrating environmental
structure and forms no part of the claimed design.

1 Claim, 2 Drawing Sheets

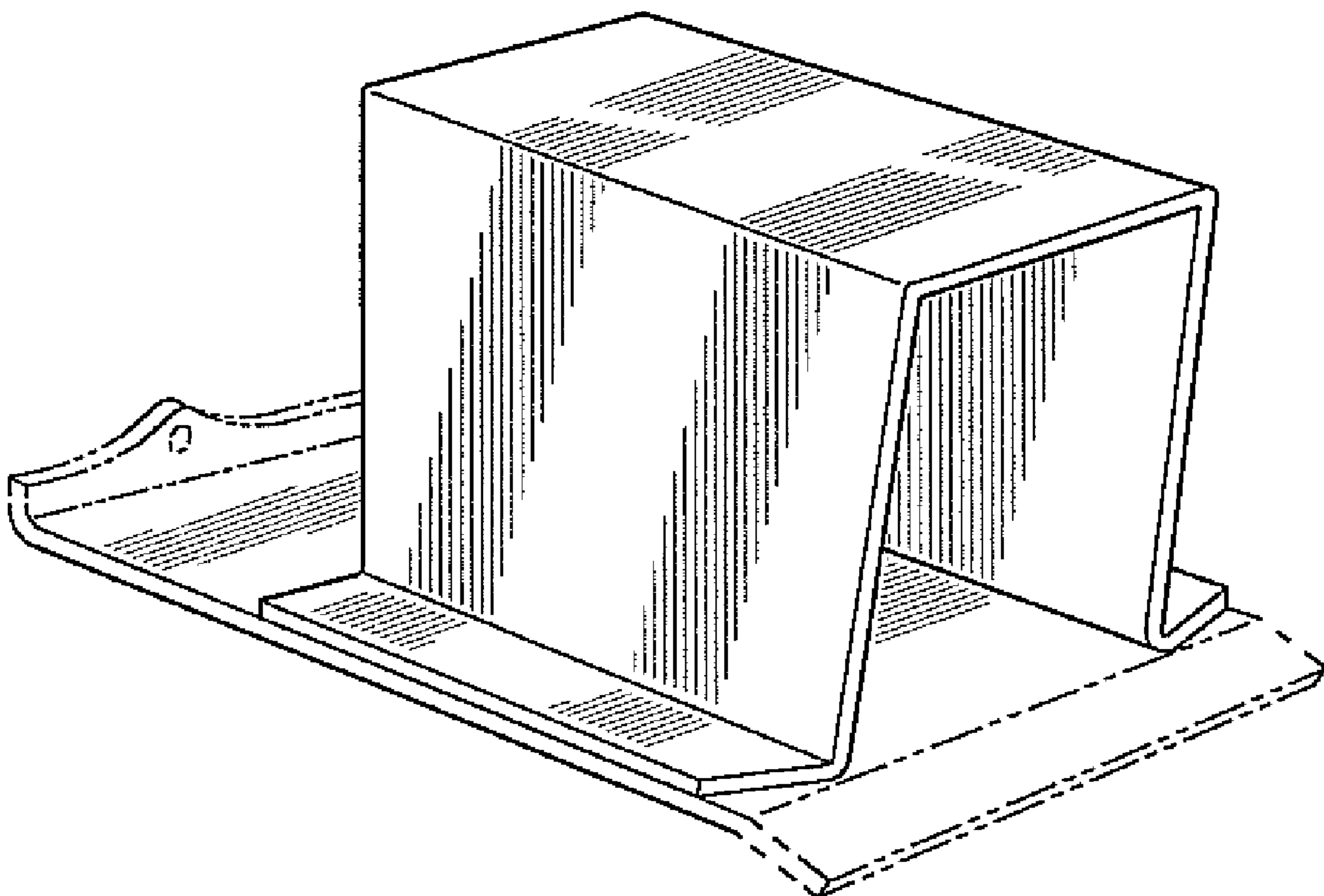

Fig-1

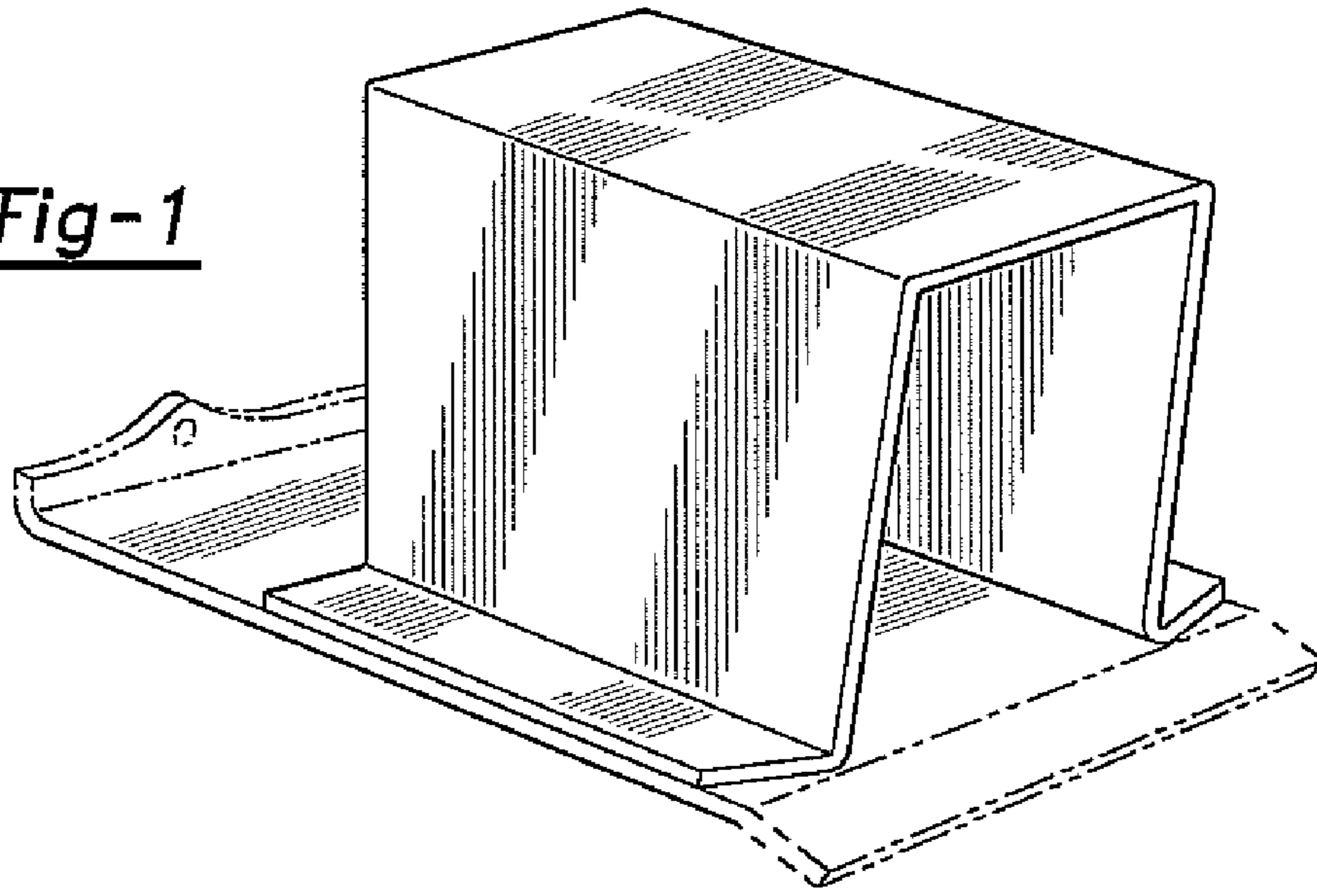

Fig-2

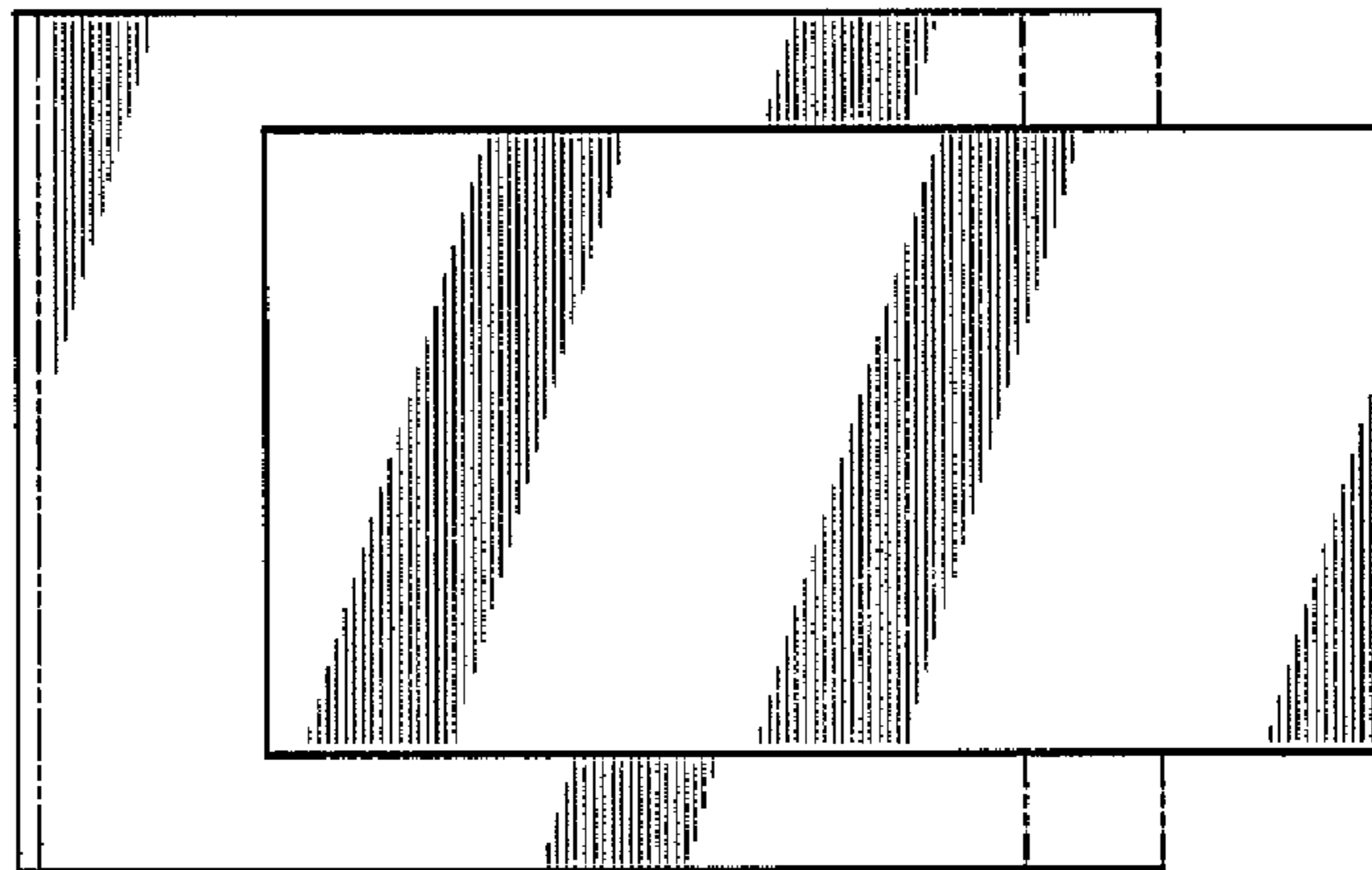
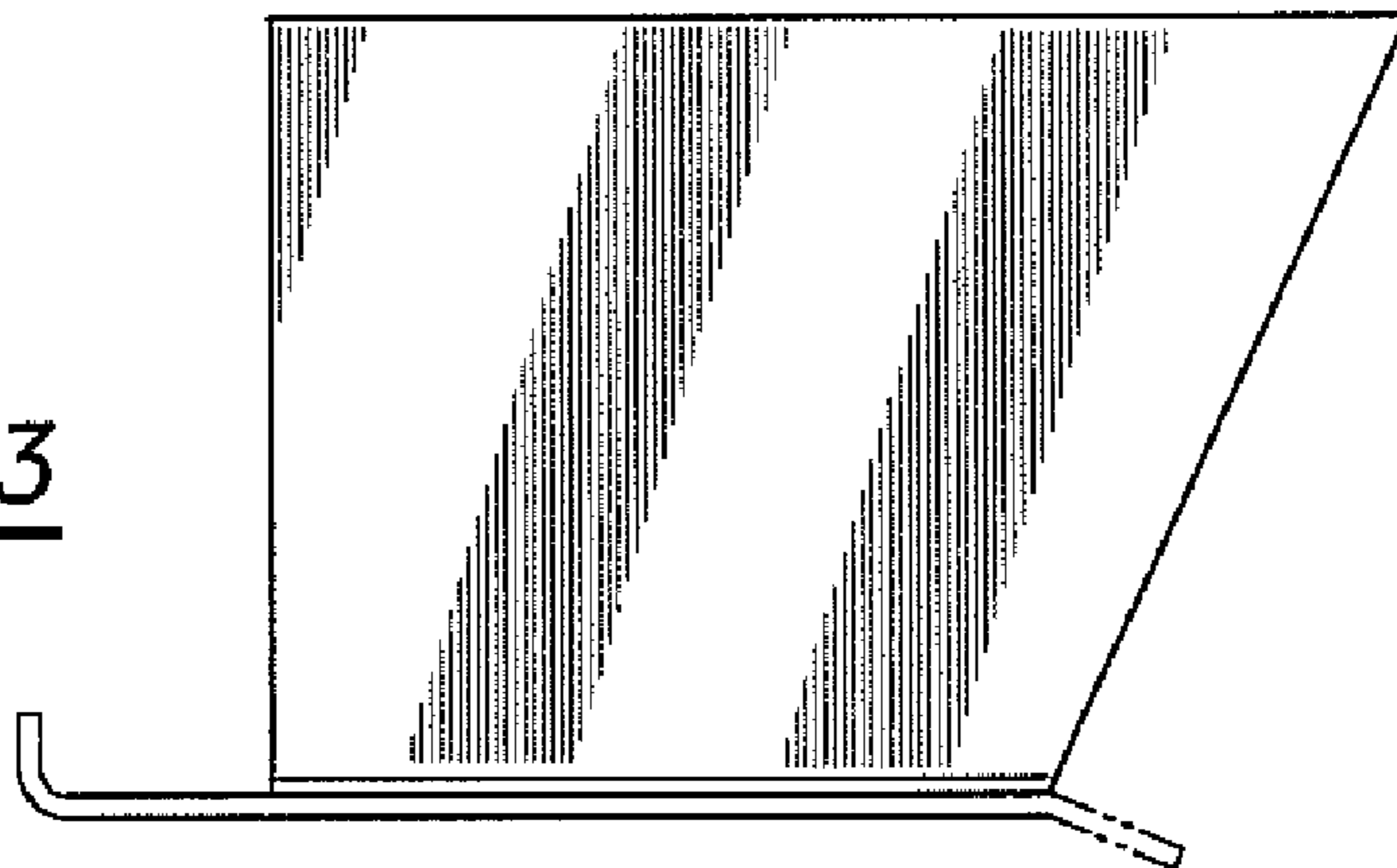

Fig-3



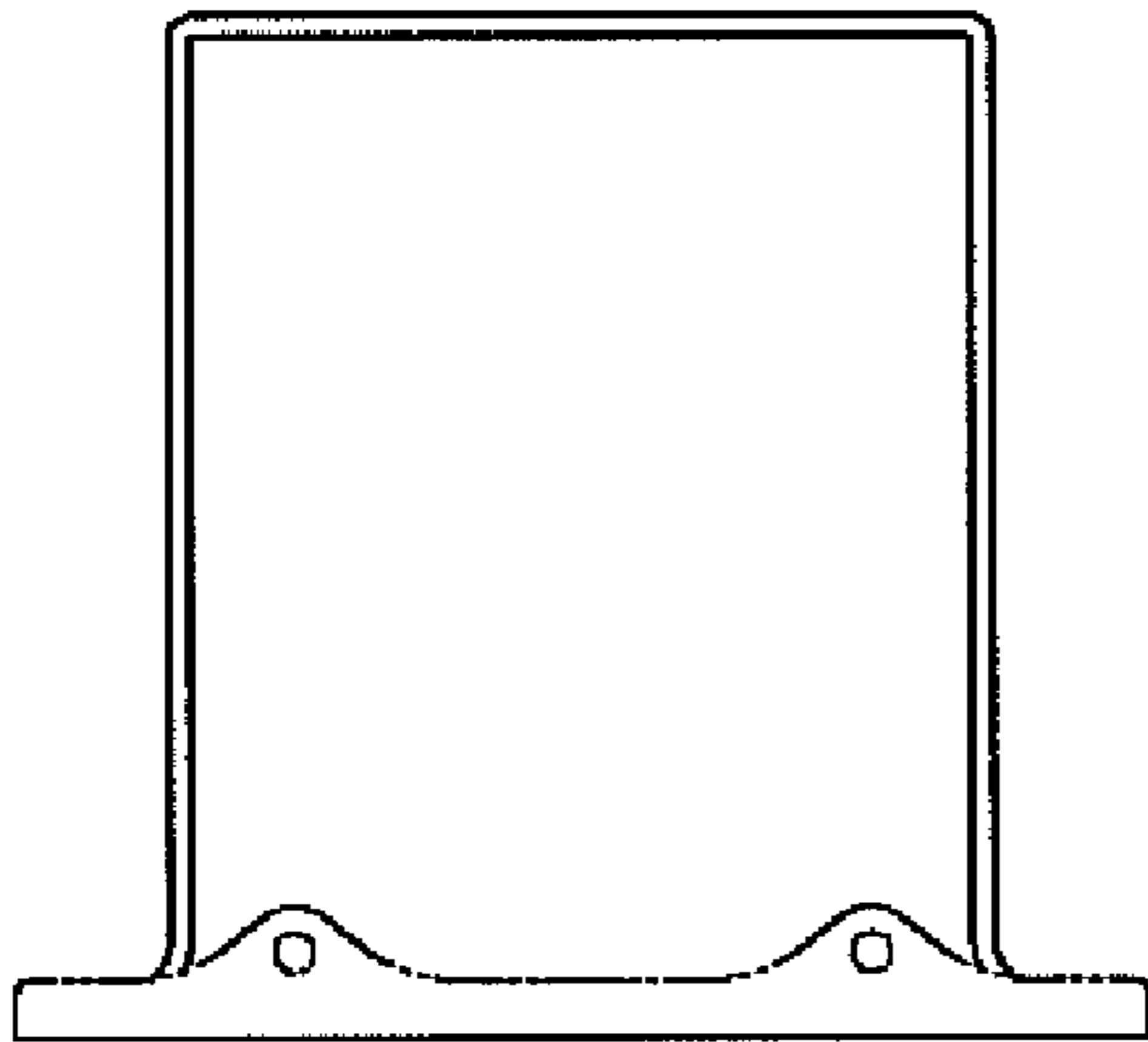

Fig-4

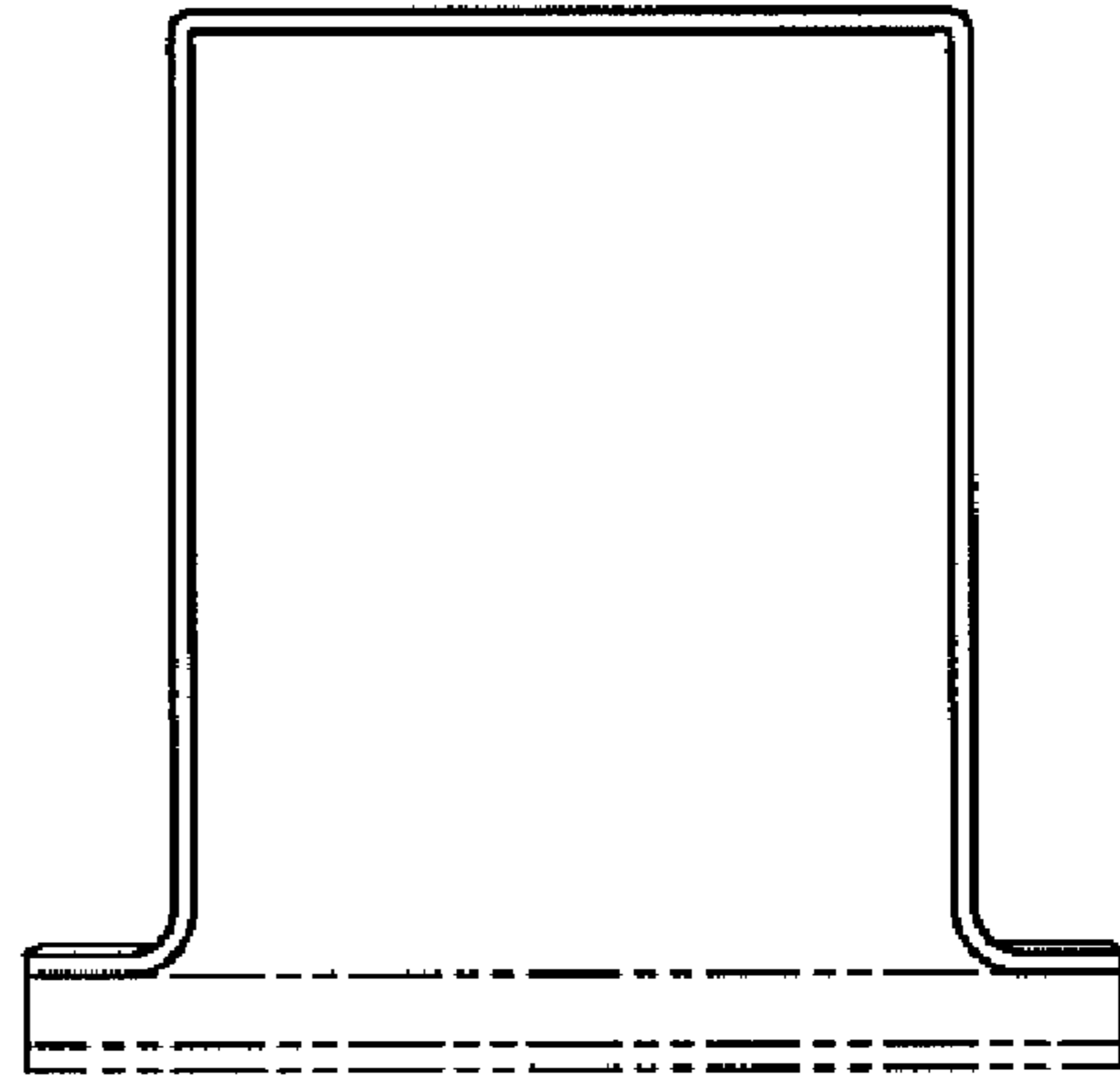

Fig-5

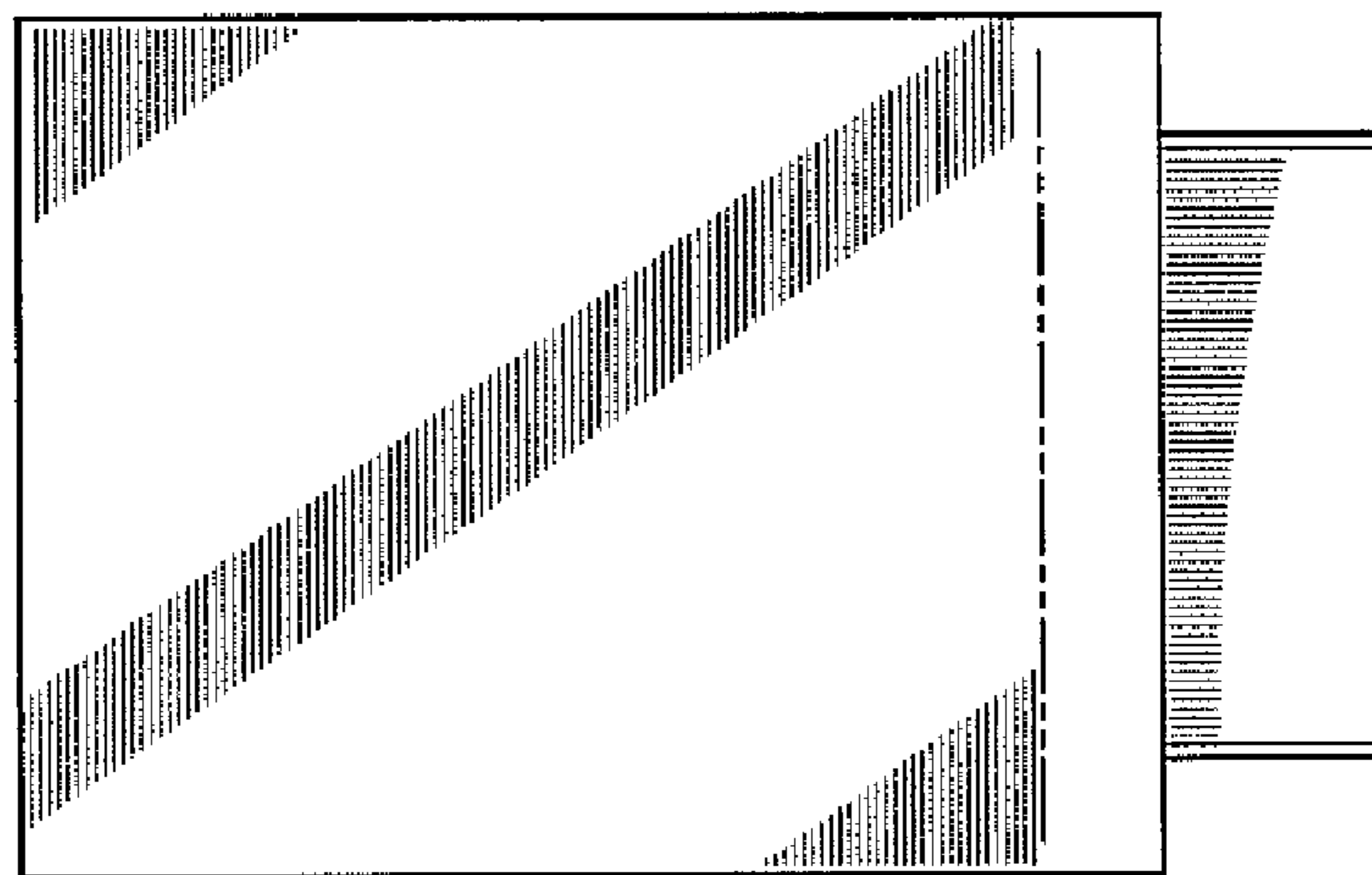

Fig-6