



US00D601058S

(12) **United States Design Patent**
Evenson et al.

(10) **Patent No.:** **US D601,058 S**

(45) **Date of Patent:** **** Sep. 29, 2009**

(54) **BODY PANELS FOR AN OFF ROAD FOUR WHEEL VEHICLE**

Yamaha® 2008 Rhino™ 4x4 Recreational Utility Vehicle brochure (front cover, back cover, and inside page).

(75) Inventors: **Lucas Evenson**, Perham, MN (US); **Scott Hovda**, Perham, MN (US); **Jerud Mikkelson**, Perham, MN (US); **Dave Wittmer**, Perham, MN (US); **Justin Esser**, Perham, MN (US)

* cited by examiner

Primary Examiner—Antoine D Davis
(74) *Attorney, Agent, or Firm*—Hamre, Schumann, Mueller & Larson, P.C.

(73) Assignee: **Redline Performance Products, LLC**, Perham, MN (US)

(57) **CLAIM**

The ornamental design for body panels for an off-road four wheel vehicle, as shown and described.

(**) Term: **14 Years**

(21) Appl. No.: **29/310,141**

DESCRIPTION

(22) Filed: **Jul. 28, 2008**

(51) **LOC (9) Cl.** **12-08**

(52) **U.S. Cl.** **D12/87; D12/107**

(58) **Field of Classification Search** D12/82, D12/87, 93, 107, 3, 86, 110; 180/225, 229, 180/233, 311, 312, 315, 223

FIG. 1 is an exploded perspective view of the body panels for an off-road four wheel vehicle according to our new design;

FIG. 2 is an exploded right side view of the body panels for an off-road four wheel vehicle in FIG. 1;

FIG. 3 is an exploded left side view of the body panels for an off-road four wheel vehicle in FIG. 1;

FIG. 4 is an exploded front view of the body panels for an off-road four wheel vehicle depicted in FIG. 1;

FIG. 5 is an exploded rear view of the body panels for an off-road four wheel vehicle in FIG. 1;

FIG. 6 is an exploded top view of the body panels for an off-road four wheel vehicle in FIG. 1;

FIG. 7 is an exploded bottom view of the body panels for an off-road four wheel vehicle depicted in FIG. 1.

FIG. 8 is a left side view of the body panels in an assembled configuration.

FIG. 9 is a front view of the body panels in an assembled configuration; and,

FIG. 10 is a top view of the body panels in an assembled configuration.

The broken lines in the drawings are for illustrative purposes only and form no part of the claimed design.

See application file for complete search history.

(56) **References Cited**

U.S. PATENT DOCUMENTS

D531,088	S	*	10/2006	Lin	D12/107
D555,036	S	*	11/2007	Eck	D12/87
2004/0084228	A1	*	5/2004	Hurlburt	180/22
2008/0023249	A1	*	1/2008	Sunsdahl et al.	180/312
2008/0053738	A1	*	3/2008	Kosuge et al.	180/311
2008/0265609	A1	*	10/2008	Orrell et al.	296/107.07
2008/0289896	A1	*	11/2008	Kosuge et al.	180/312
2009/0000849	A1	*	1/2009	Leonard et al.	180/311

OTHER PUBLICATIONS

Kawasaki® 2008 Teryx™ Recreational Utility Vehicle brochure (front cover, back cover, and inside page).
Polaris® 2008 Ranger Recreational Utility Vehicle brochure (front cover, back cover, pp. 4-5).
Arctic Cat® 2008 Prowler Recreational Utility Vehicle brochure (front cover, back cover, p. 12).

1 Claim, 10 Drawing Sheets

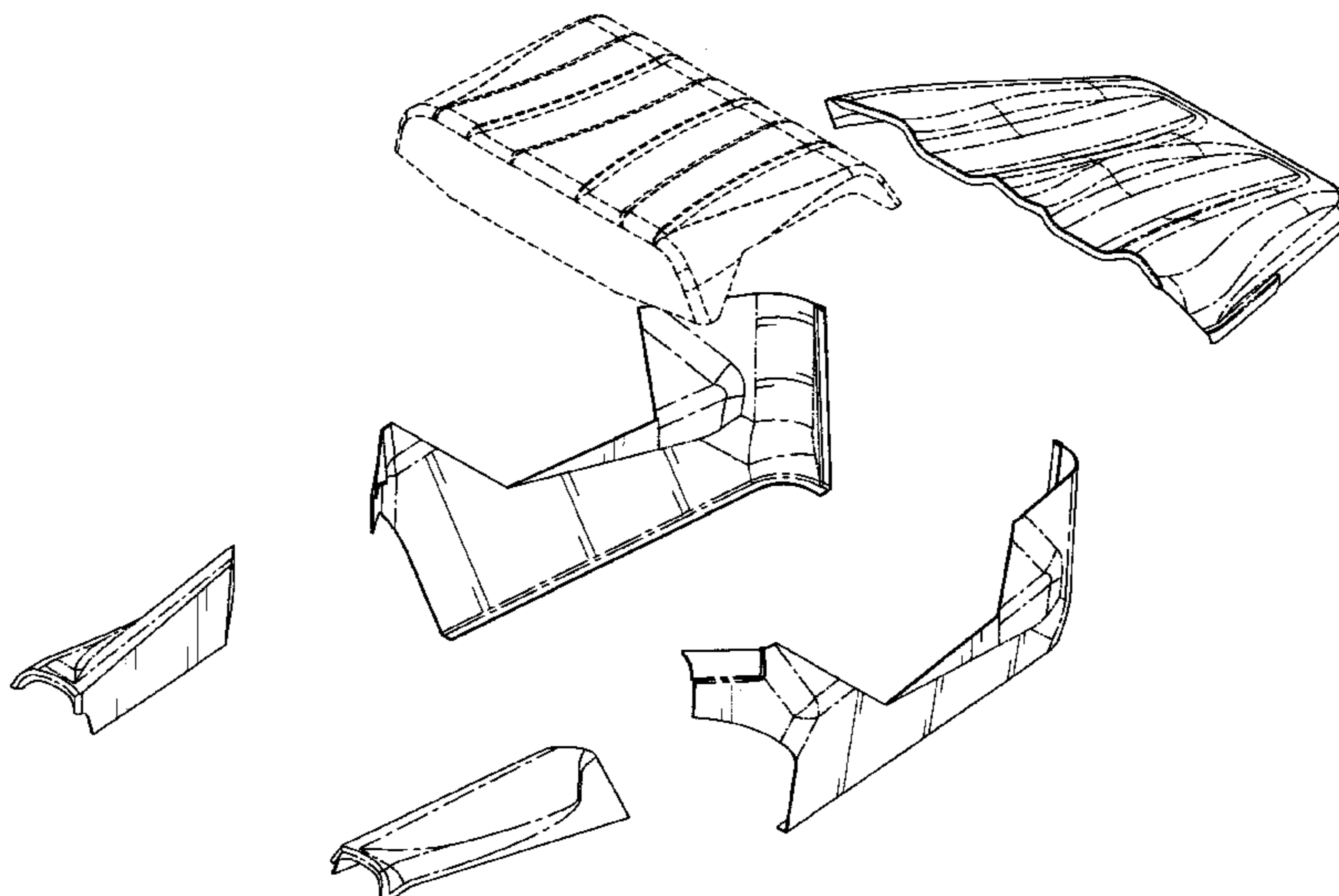

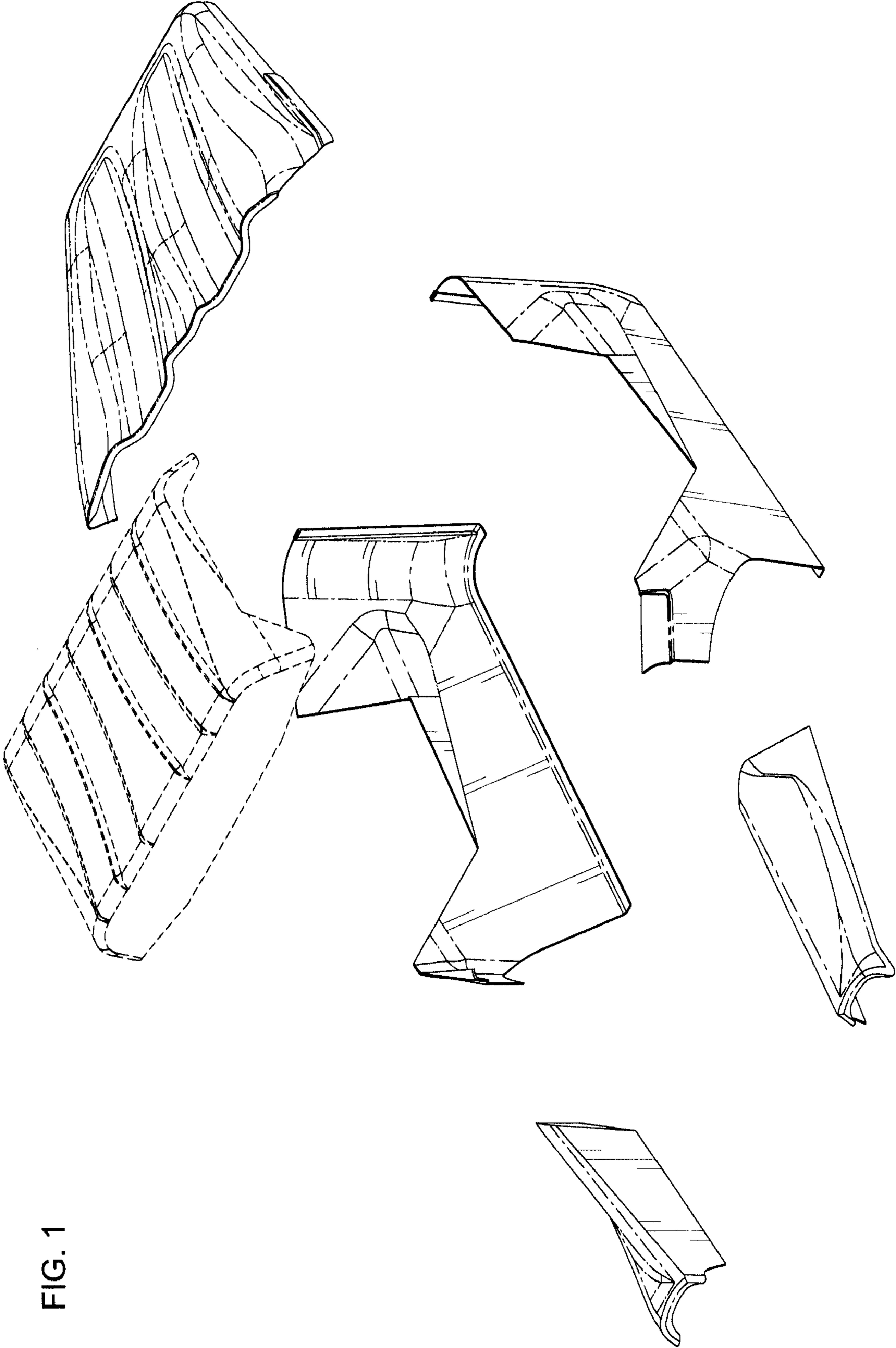

FIG. 1

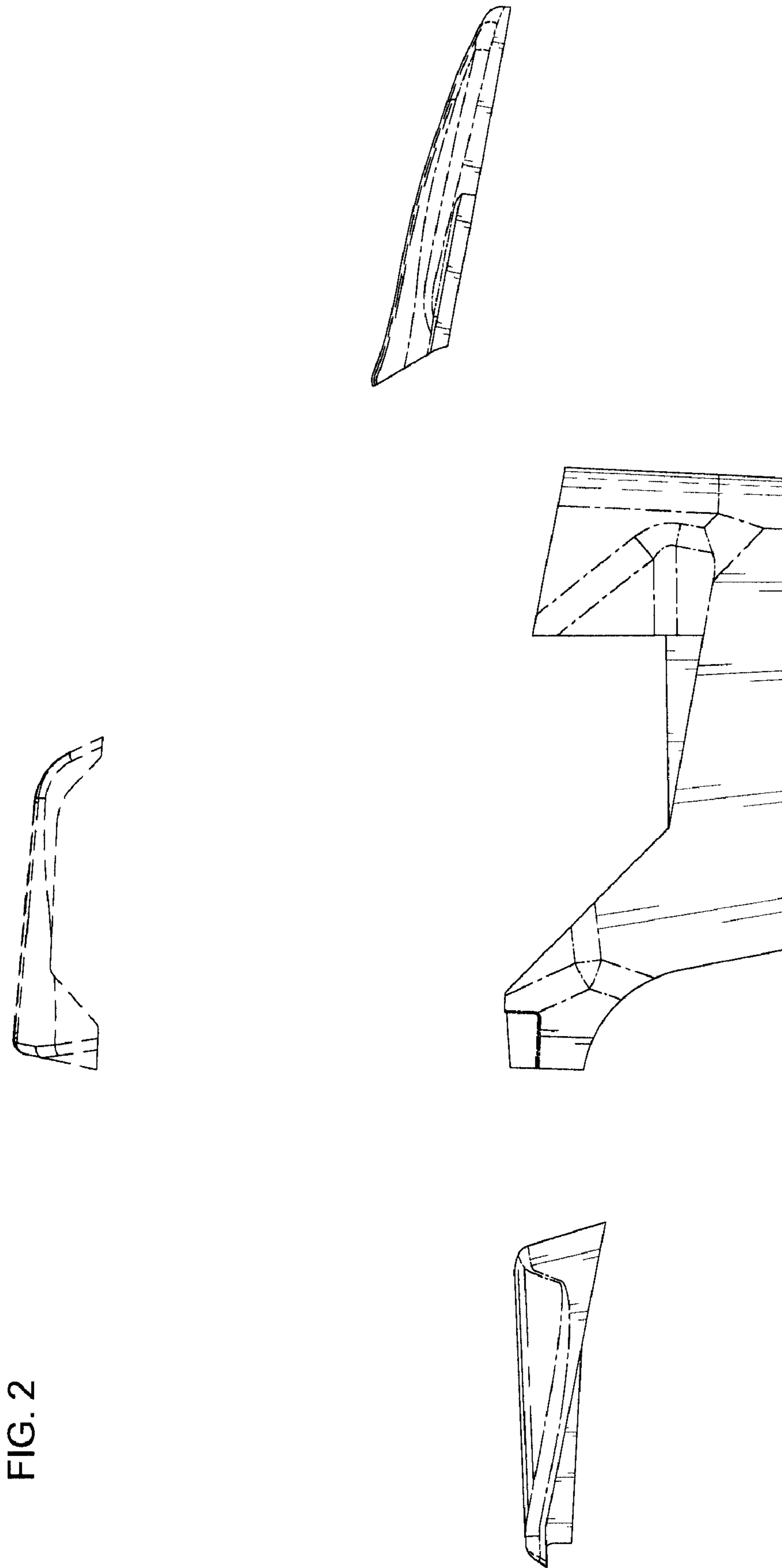

FIG. 2

FIG. 3

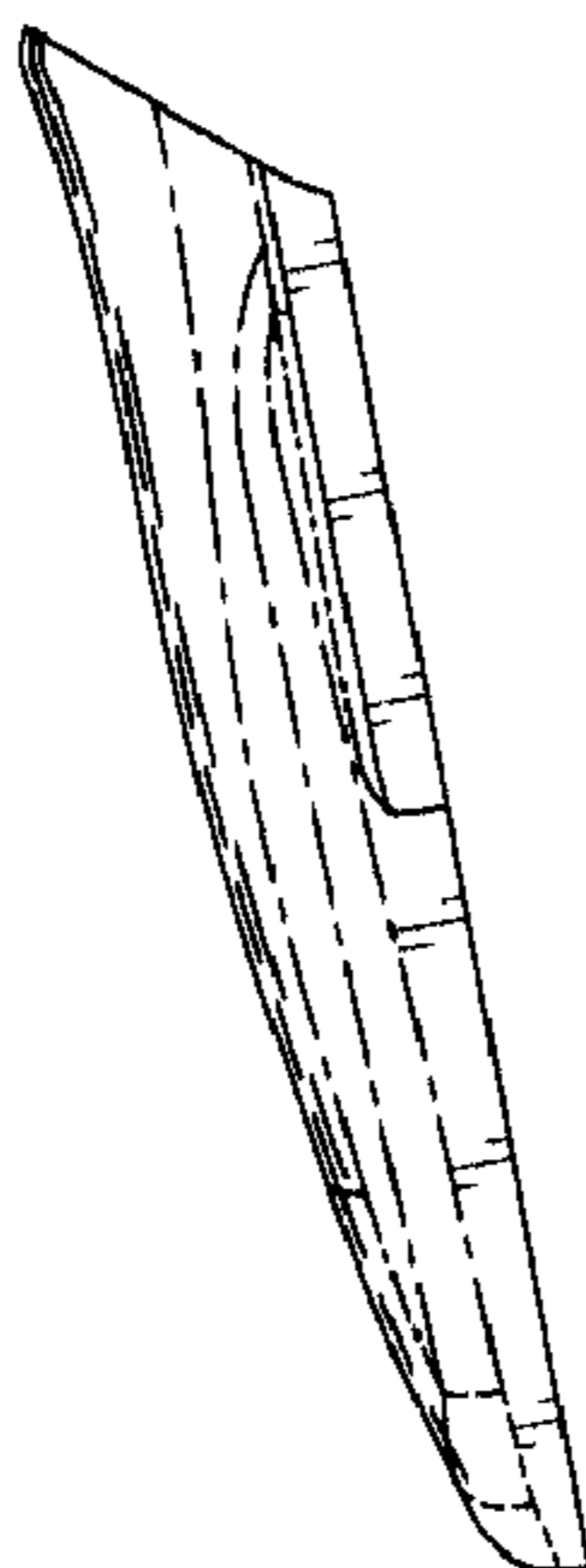
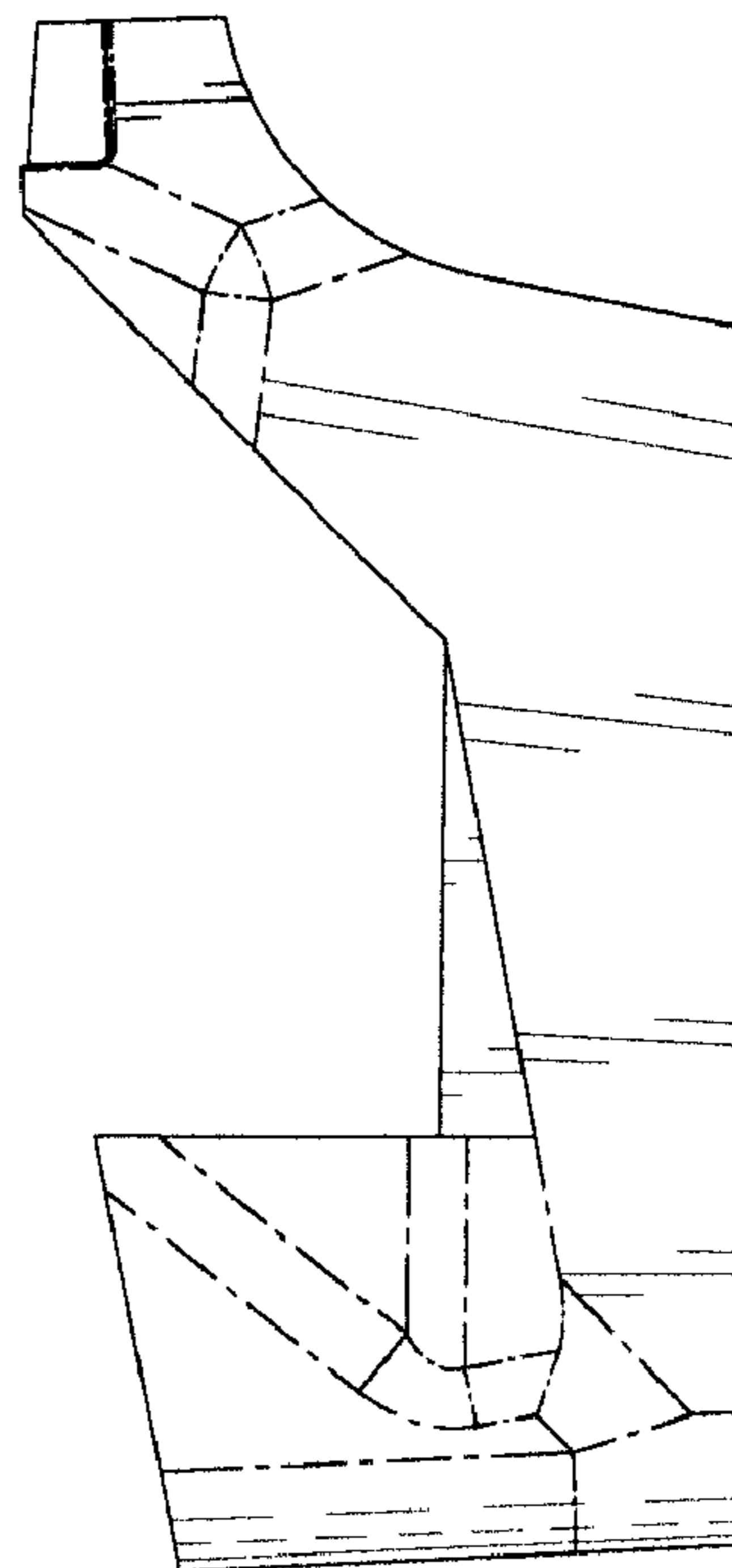
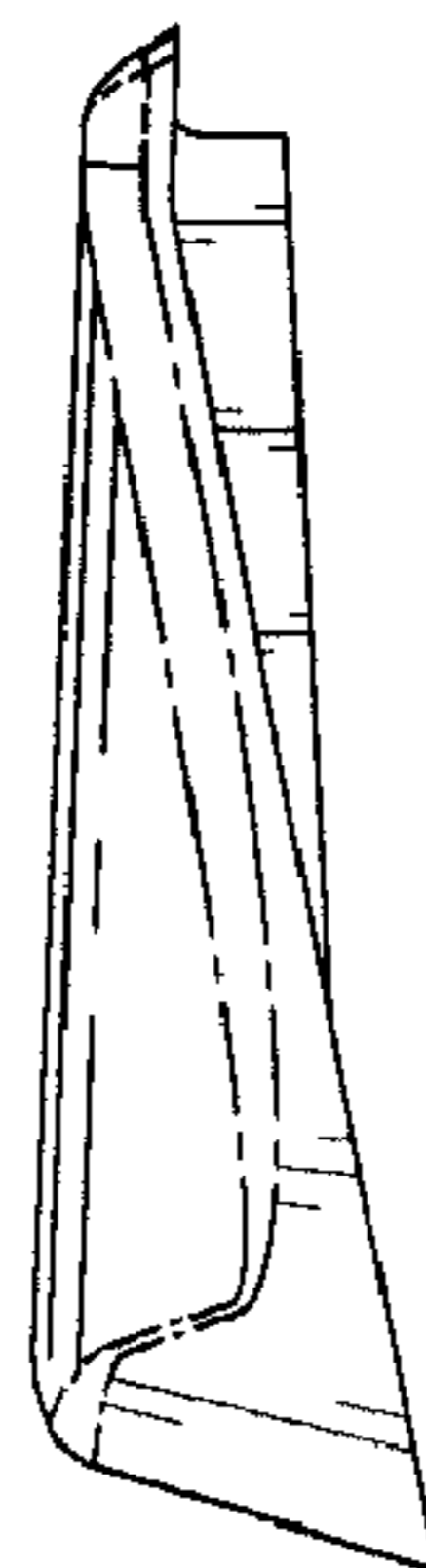

FIG. 4

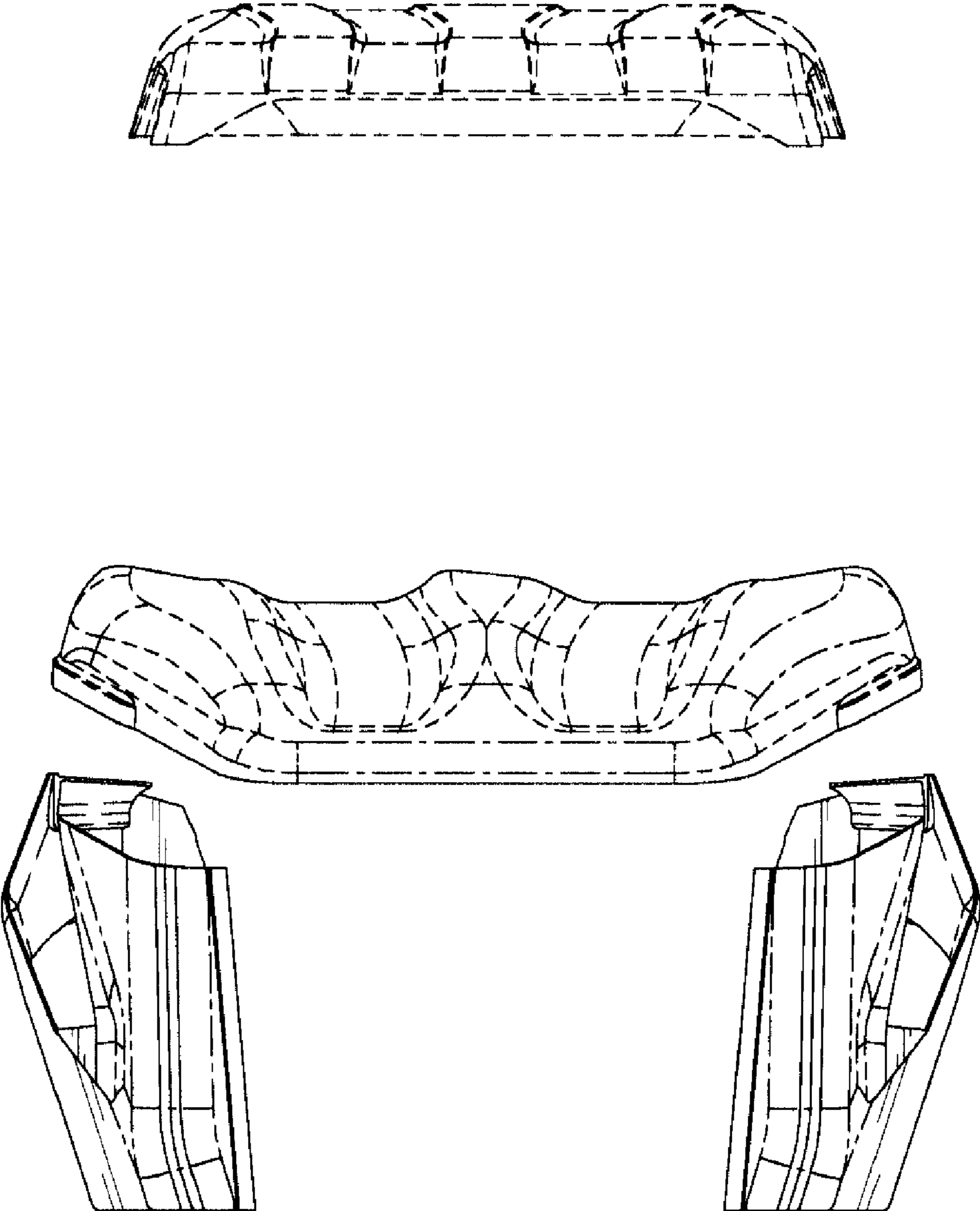
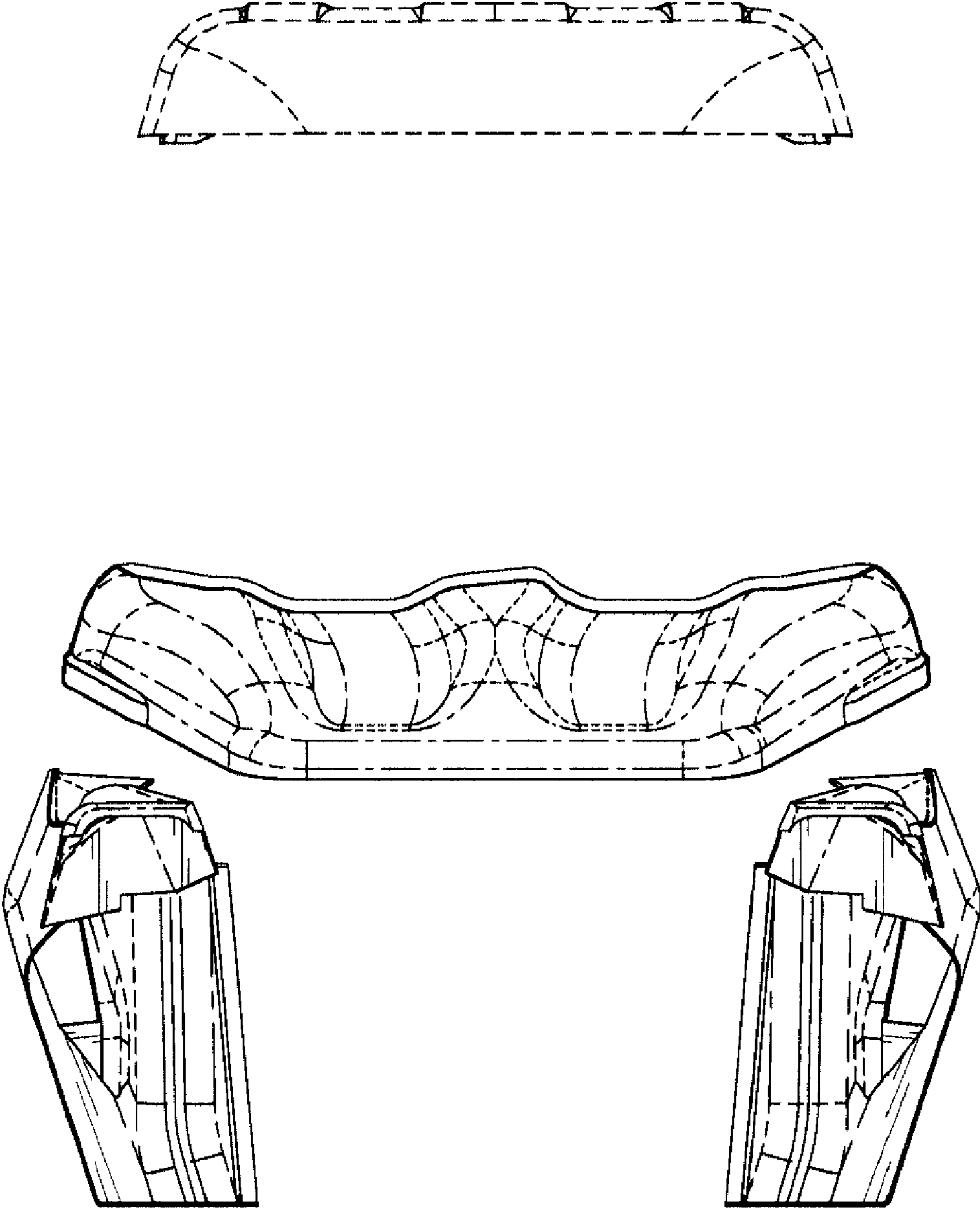

FIG. 5



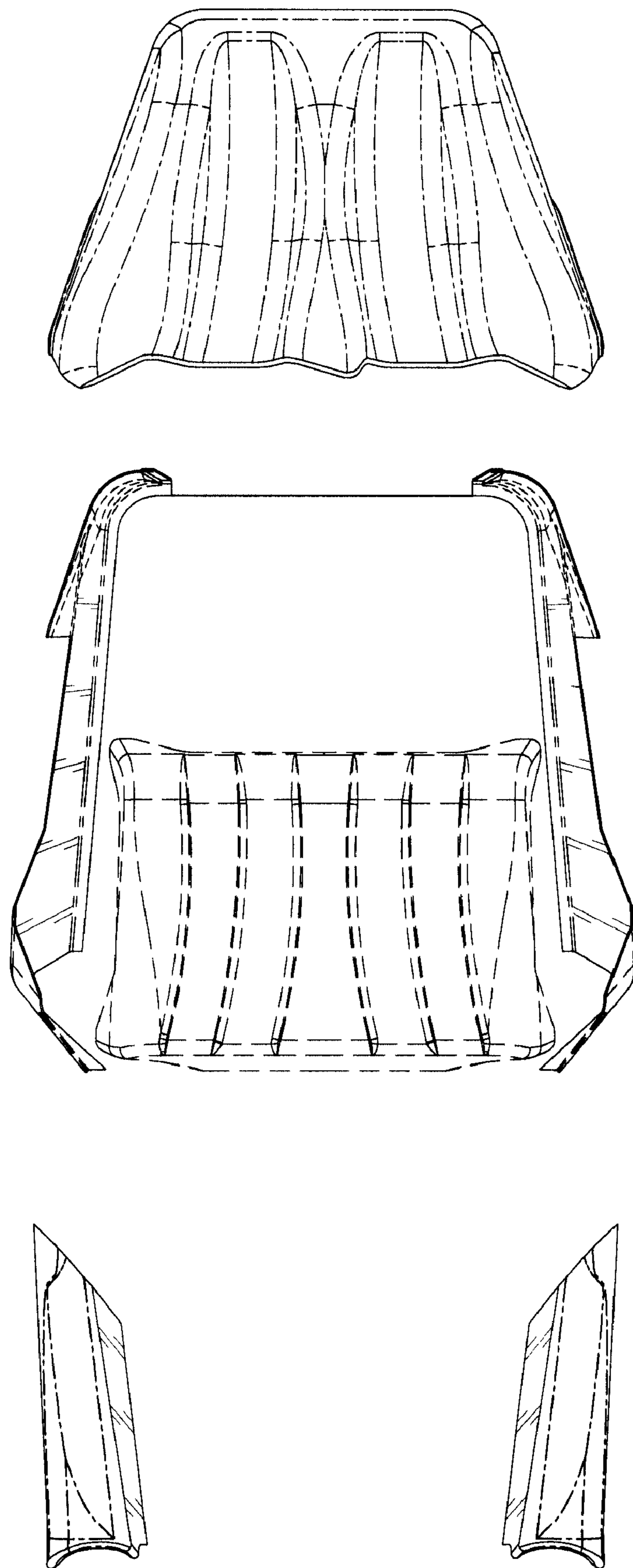

FIG. 6

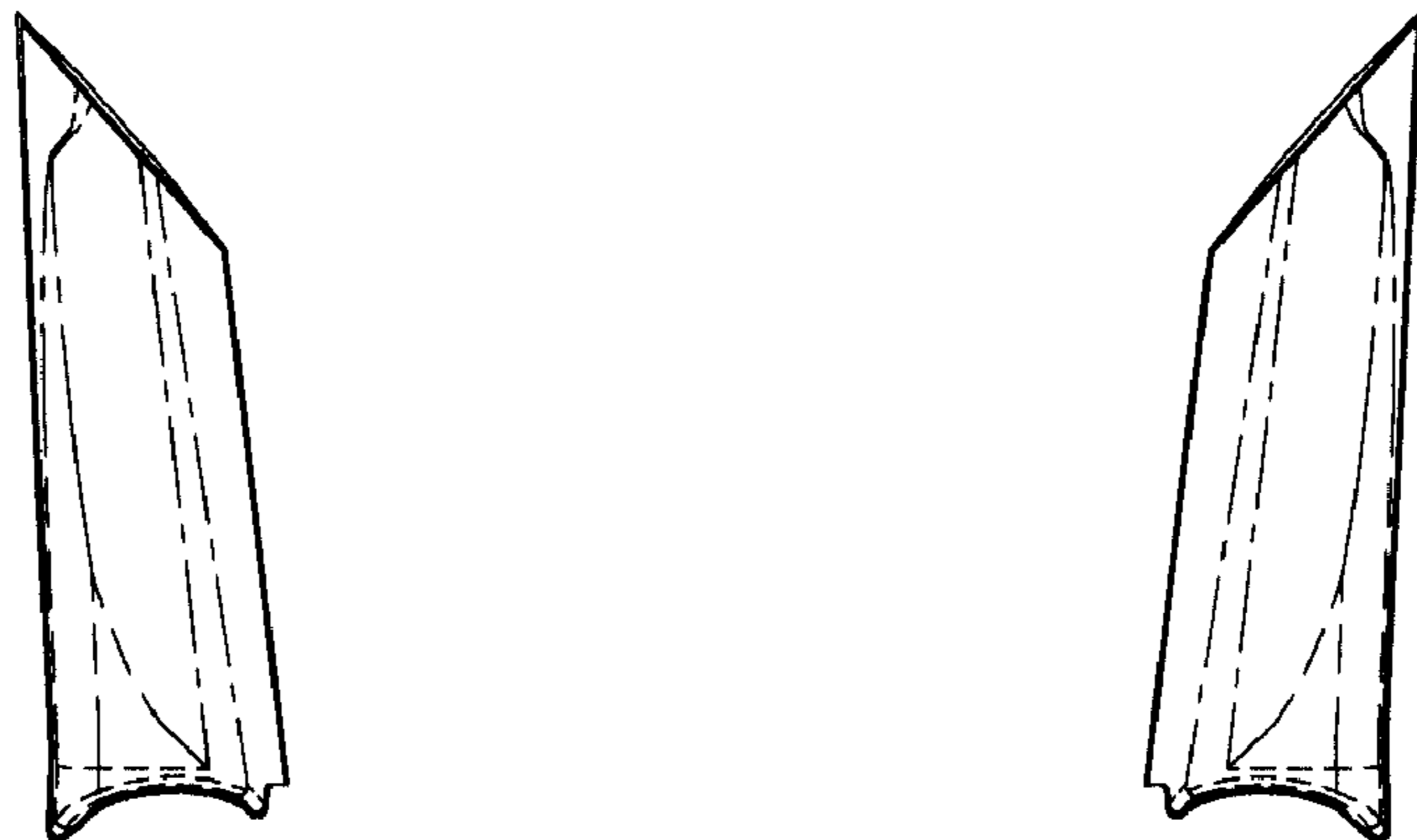
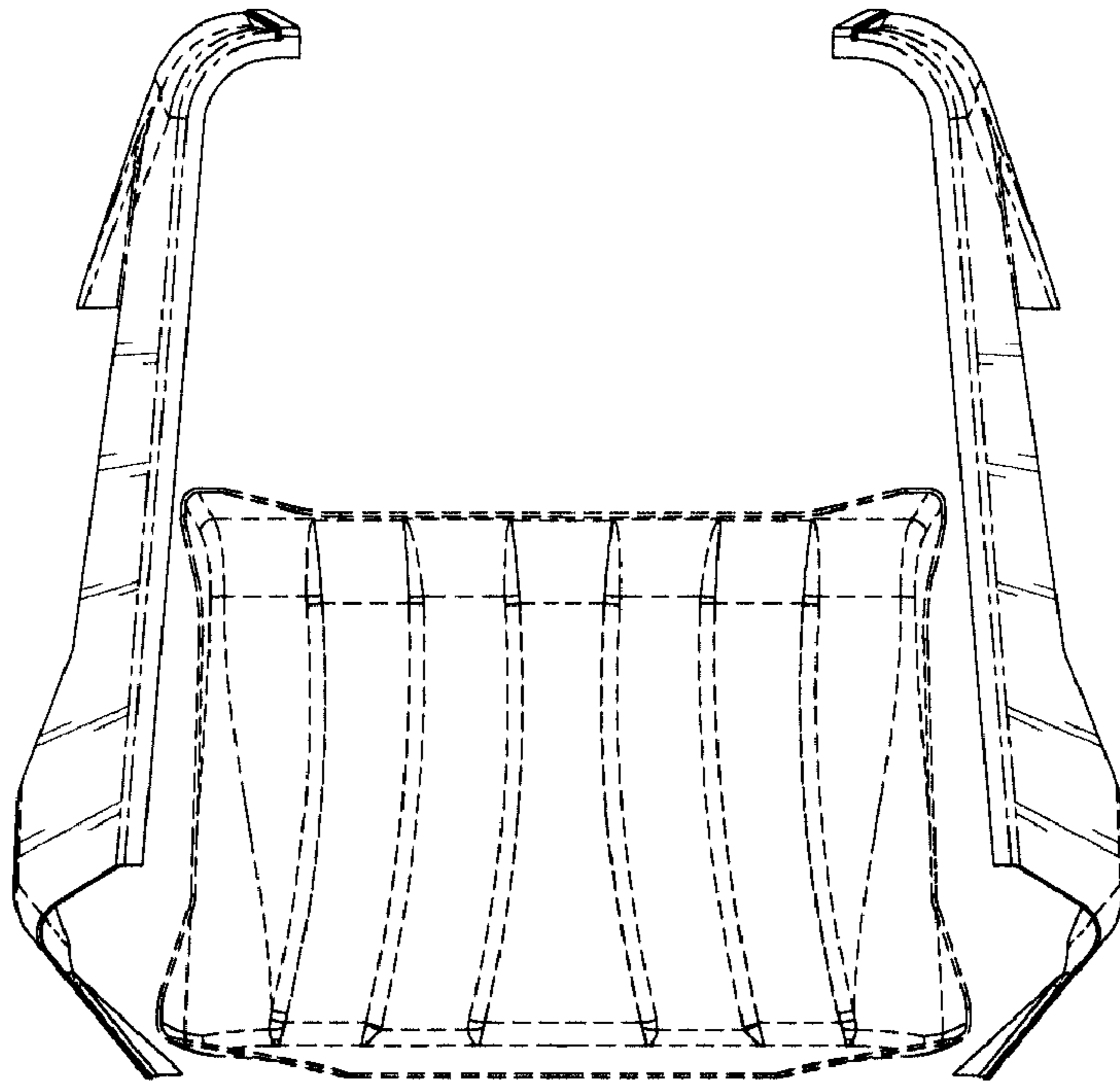
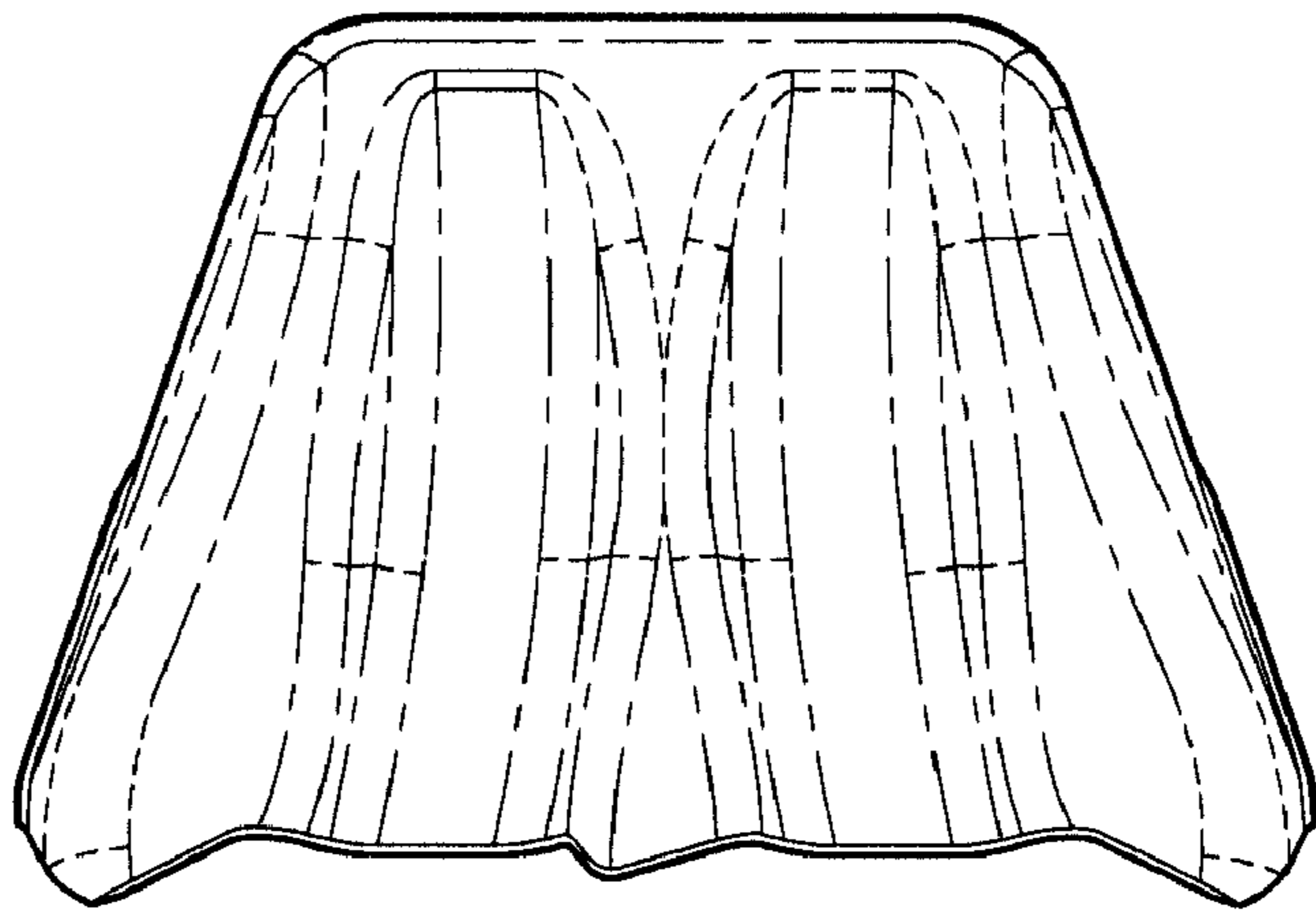

FIG. 7

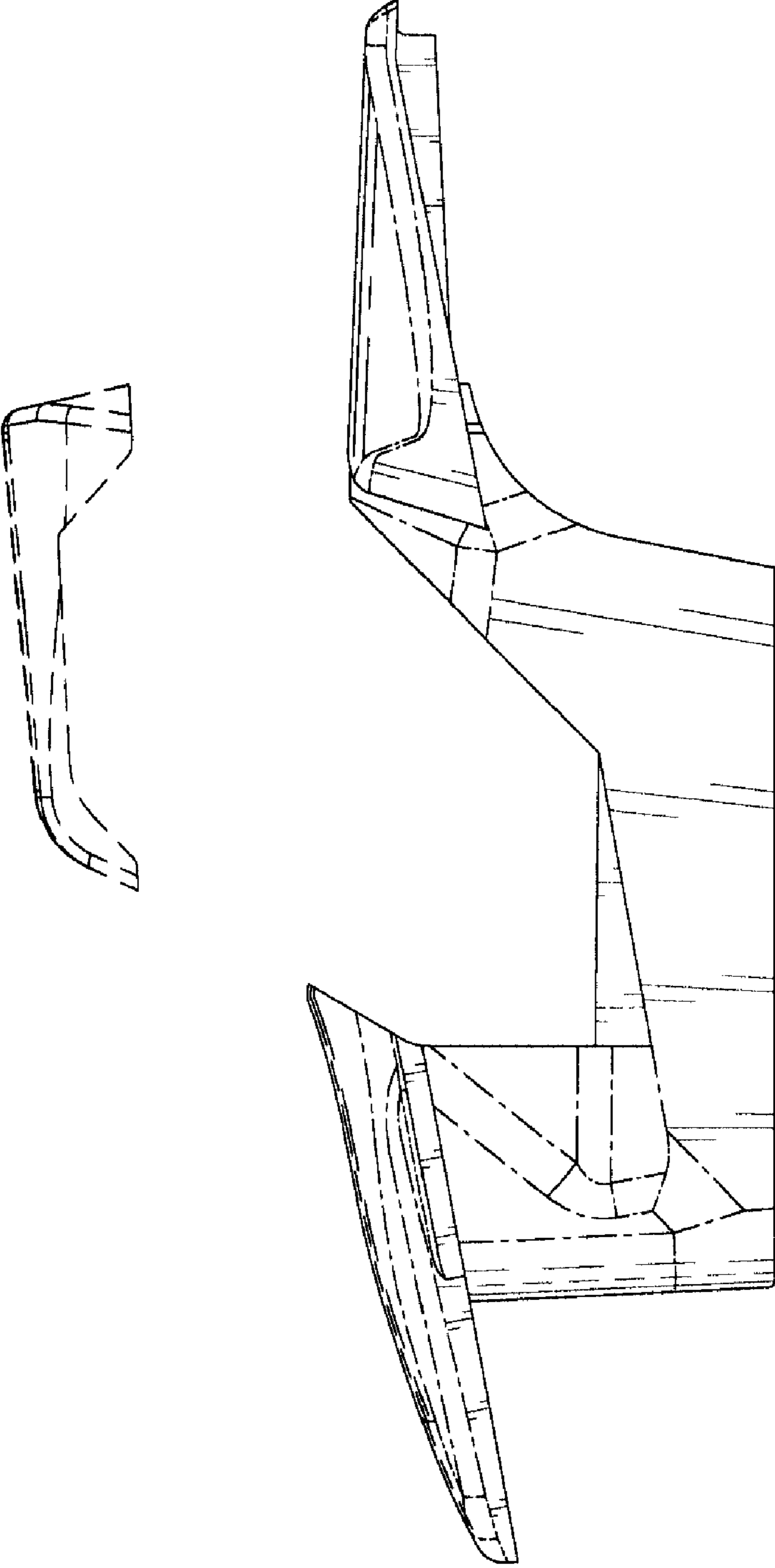

FIG. 8

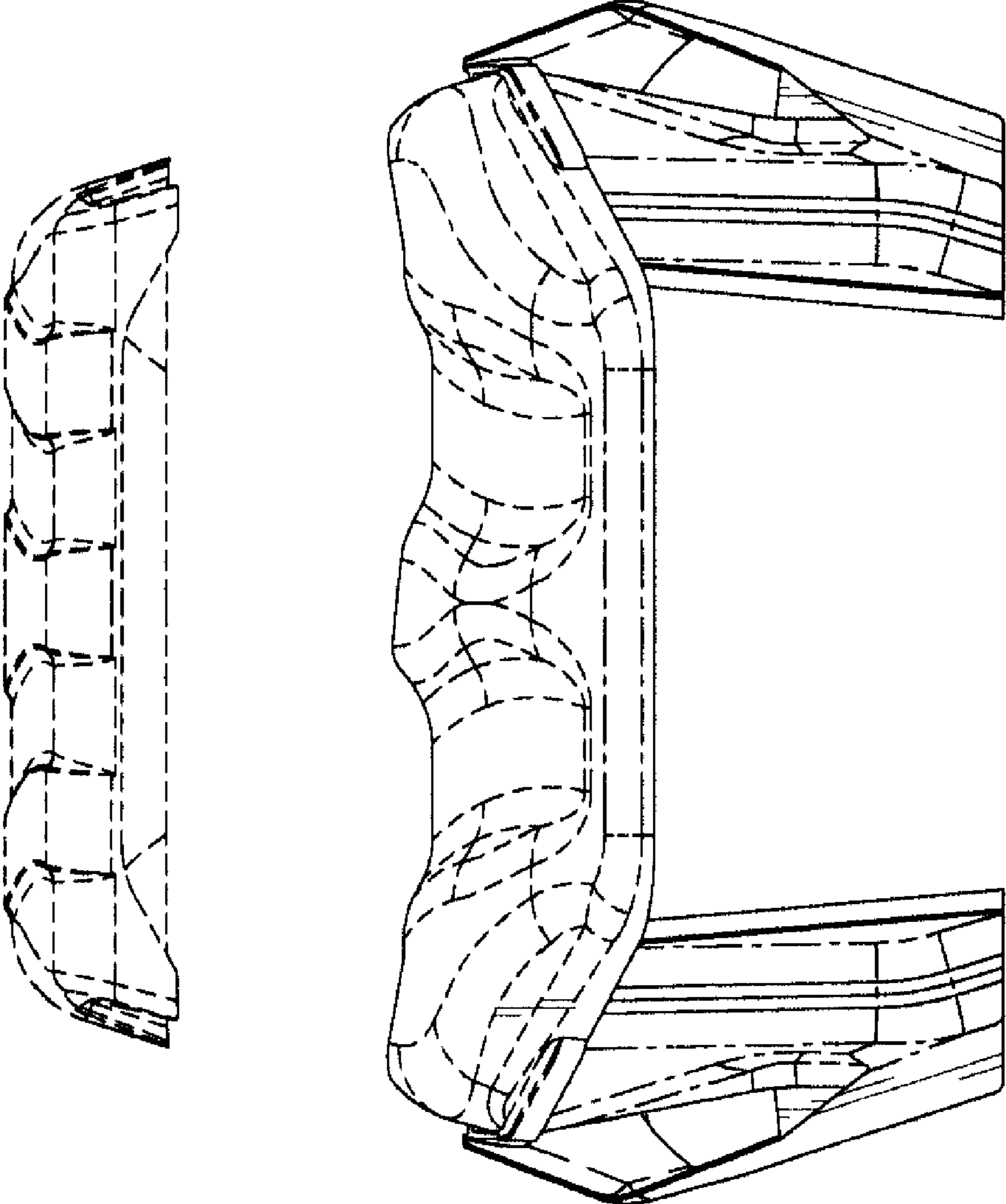

FIG. 9

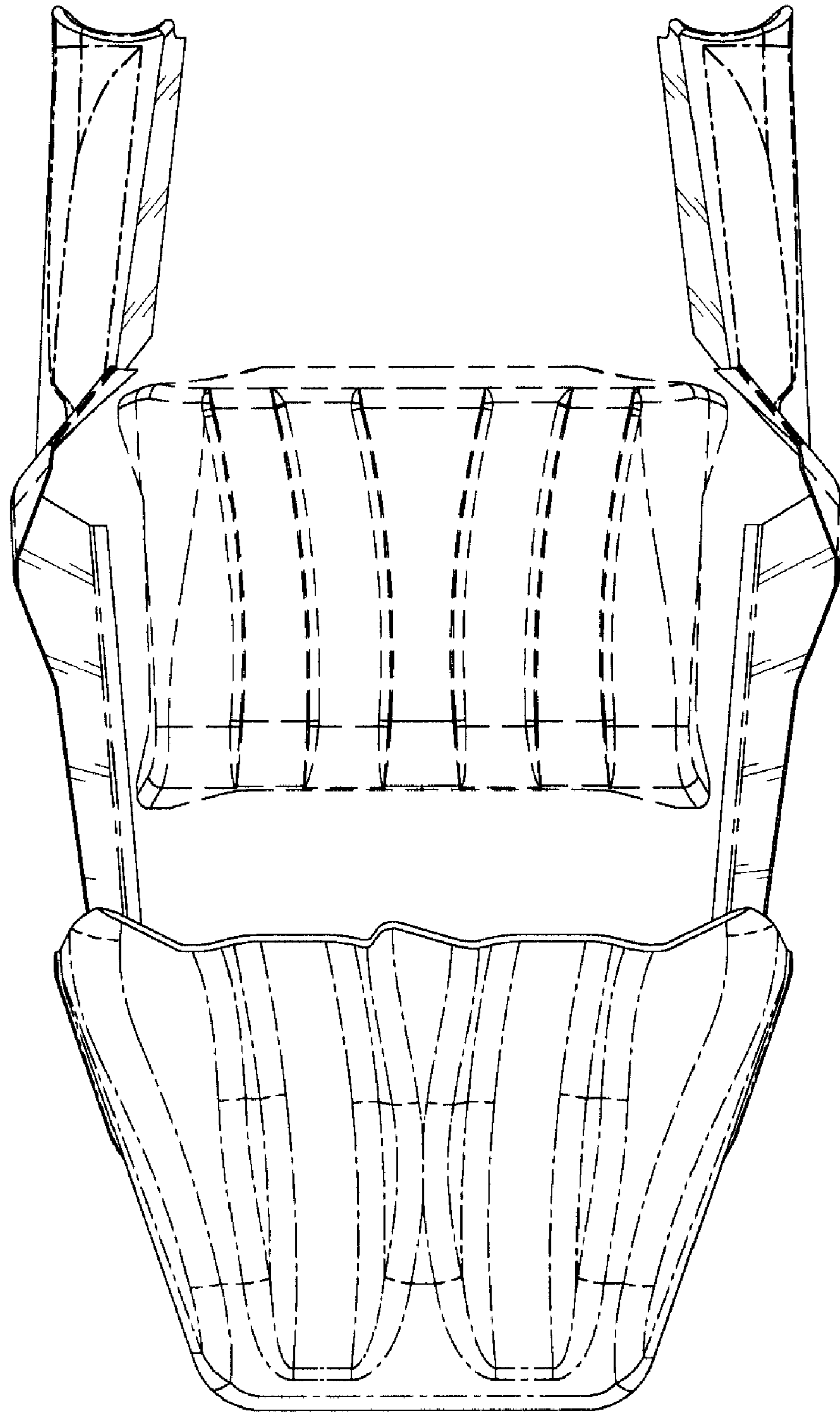

FIG. 10