



US00D600726S

(12) **United States Design Patent**  
**Claassen et al.**

(10) **Patent No.:** **US D600,726 S**

(45) **Date of Patent:** **\*\* Sep. 22, 2009**

(54) **MACHINE FOR RAPID PROTOTYPING OR RAPID MANUFACTURING**

(75) Inventors: **Arnoldus Johannes Claassen**,  
Eindhoven (NL); **Robert Fienieg**,  
Veldhoven (NL)

(73) Assignees: **Huntsman Advanced Materials Americas Inc.**, The Woodlands, TX (US); **Huntsman Advanced Materials Switzerland GbmH**, Basel (CH)

(\*\*) Term: **14 Years**

(21) Appl. No.: **29/323,056**

(22) Filed: **Aug. 15, 2008**

(30) **Foreign Application Priority Data**

Jun. 16, 2008 (EM) ..... 000951462

(51) **LOC (9) Cl.** ..... **15-99**

(52) **U.S. Cl.** ..... **D15/199**

(58) **Field of Classification Search** ..... D15/122,  
D15/135, 136, 199; D6/439-449; 118/410,  
118/642, 679, 712; 264/245, 308, 401; 427/355,  
427/402

See application file for complete search history.

(56) **References Cited**

**U.S. PATENT DOCUMENTS**

D267,689 S \* 1/1983 Platner ..... D6/432  
D288,753 S \* 3/1987 Fuss et al. .... D6/446  
D318,866 S \* 8/1991 Hillis ..... D14/308  
5,968,561 A \* 10/1999 Batchelder et al. .... 425/375  
6,261,077 B1 \* 7/2001 Bishop et al. .... 425/174.4  
D460,296 S \* 7/2002 Reese et al. .... D6/470

D530,287 S \* 10/2006 Stolpe et al. .... D13/162  
7,128,866 B1 \* 10/2006 Henningsen ..... 264/401  
7,297,304 B2 \* 11/2007 Swanson et al. .... 264/308  
7,329,379 B2 \* 2/2008 Boyd et al. .... 264/401  
D574,771 S \* 8/2008 Flanigan ..... D13/122  
2001/0048184 A1 \* 12/2001 Ueno ..... 264/401  
2004/0080078 A1 \* 4/2004 Collins ..... 264/245  
2005/0225007 A1 \* 10/2005 Lai et al. .... 264/308  
2007/0074659 A1 \* 4/2007 Wahlstrom ..... 118/679  
2007/0075459 A1 \* 4/2007 Reynolds et al. .... 264/401  
2008/0217818 A1 \* 9/2008 Holmboe et al. .... 264/401  
2008/0315461 A1 \* 12/2008 Henningsen ..... 264/401  
2009/0020919 A1 \* 1/2009 Marsac ..... 264/401

\* cited by examiner

*Primary Examiner*—Sandra Snapp

*Assistant Examiner*—Patricia Palasik

(74) *Attorney, Agent, or Firm*—Patterson & Sheridan, LLP

(57) **CLAIM**

The ornamental design for a machine for rapid prototyping or rapid manufacturing, as shown and described.

**DESCRIPTION**

FIG. 1 is a perspective view of a machine for rapid prototyping or rapid manufacturing showing our new design.

FIG. 2 is a front view of the machine of FIG. 1.

FIG. 3 is a rear view of the machine of FIG. 1.

FIG. 4 is a left view of the machine of FIG. 1.

FIG. 5 is a right view of the machine of FIG. 1; and,

FIG. 6 is a top view of the machine of FIG. 1.

The broken lines in the drawings depict unclaimed environmental subject matter.

**1 Claim, 6 Drawing Sheets**

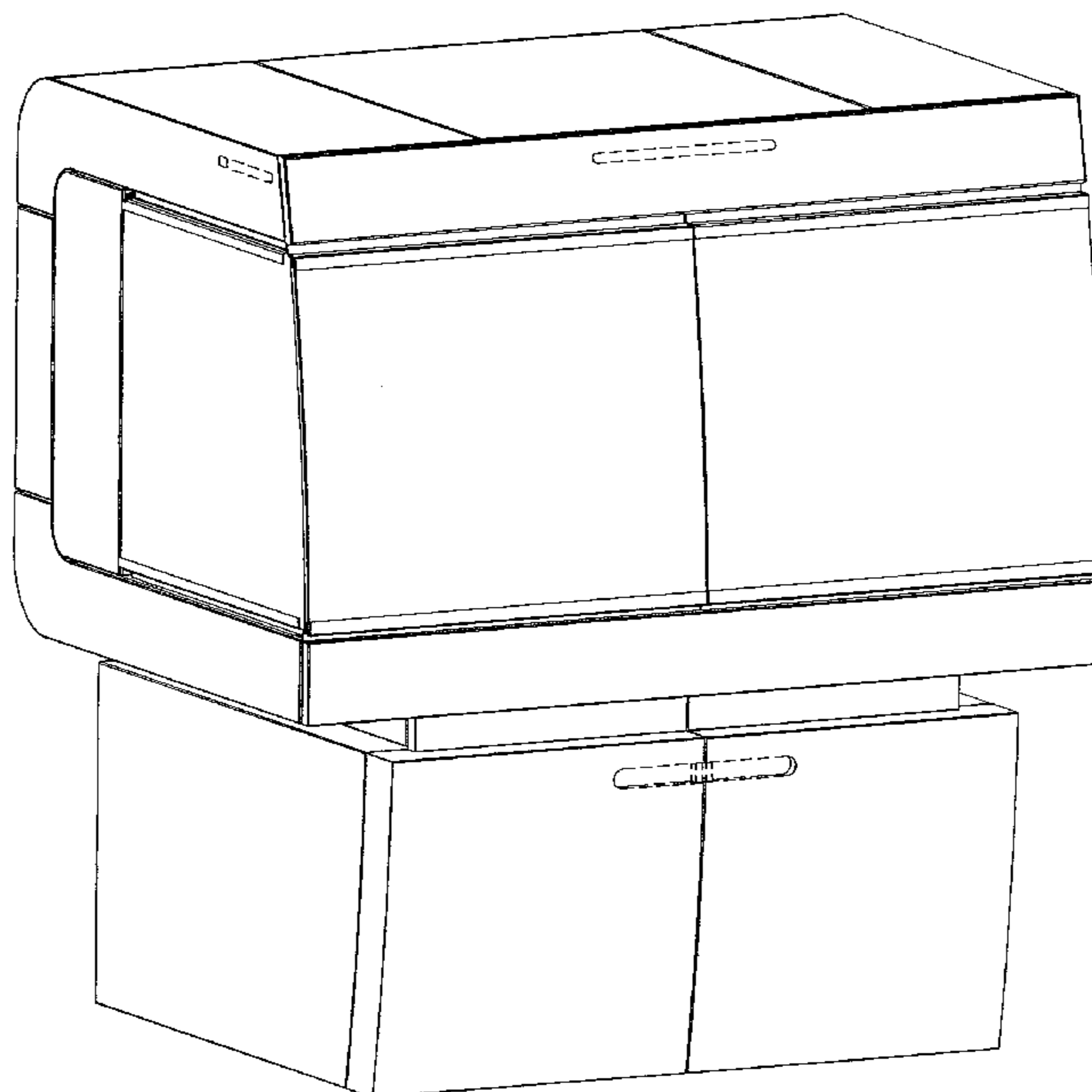

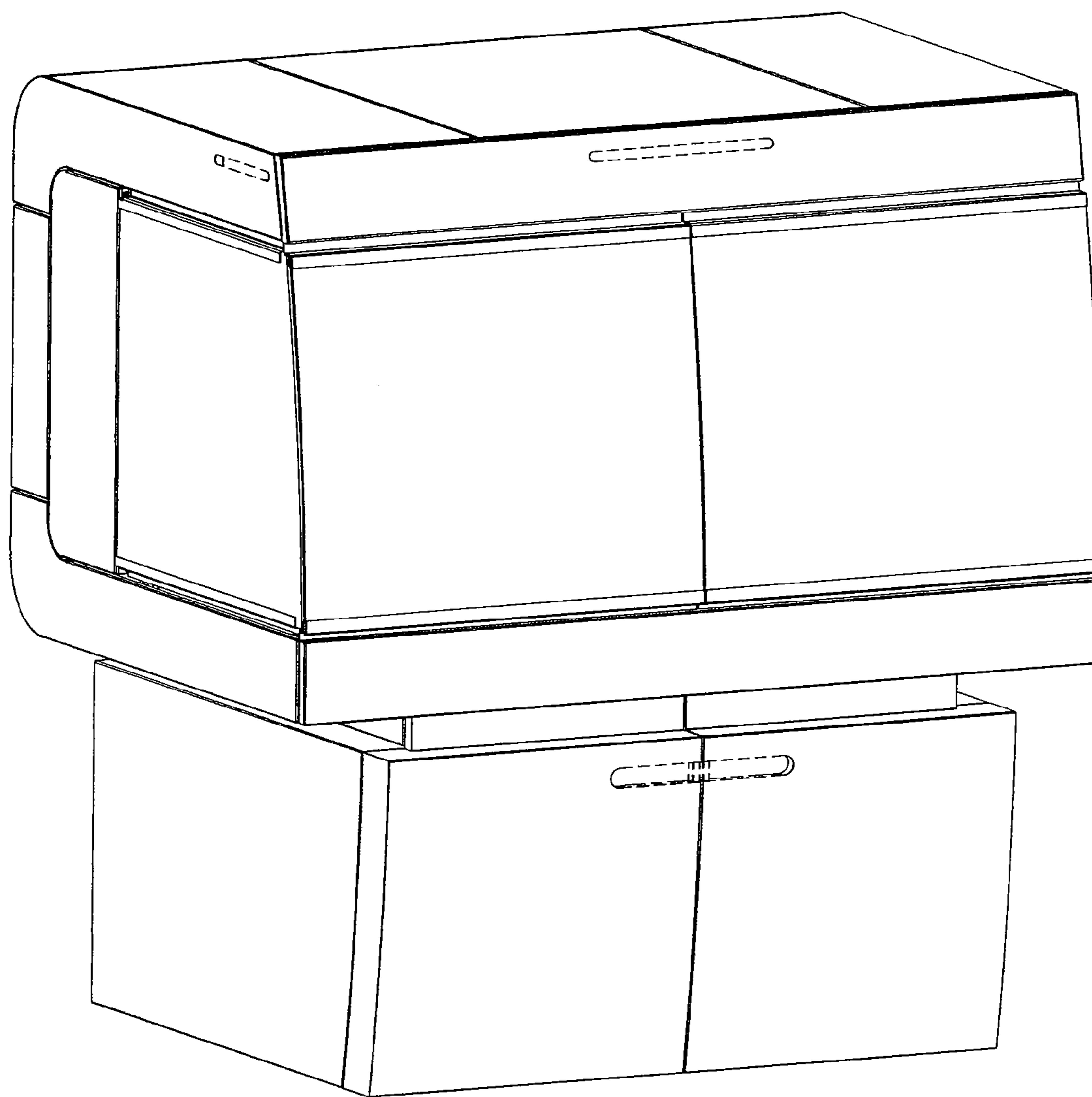

FIG. 1

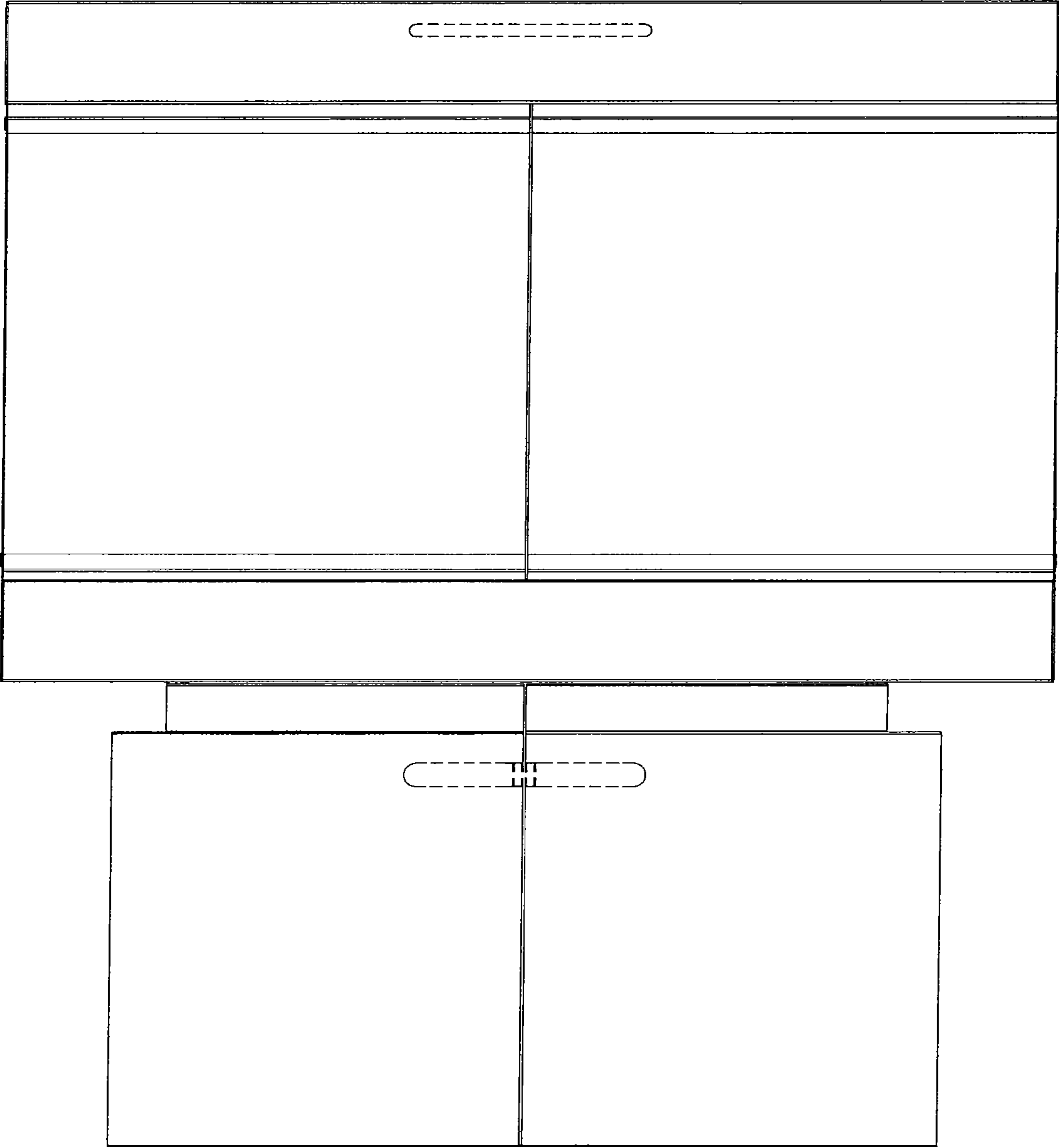

FIG. 2

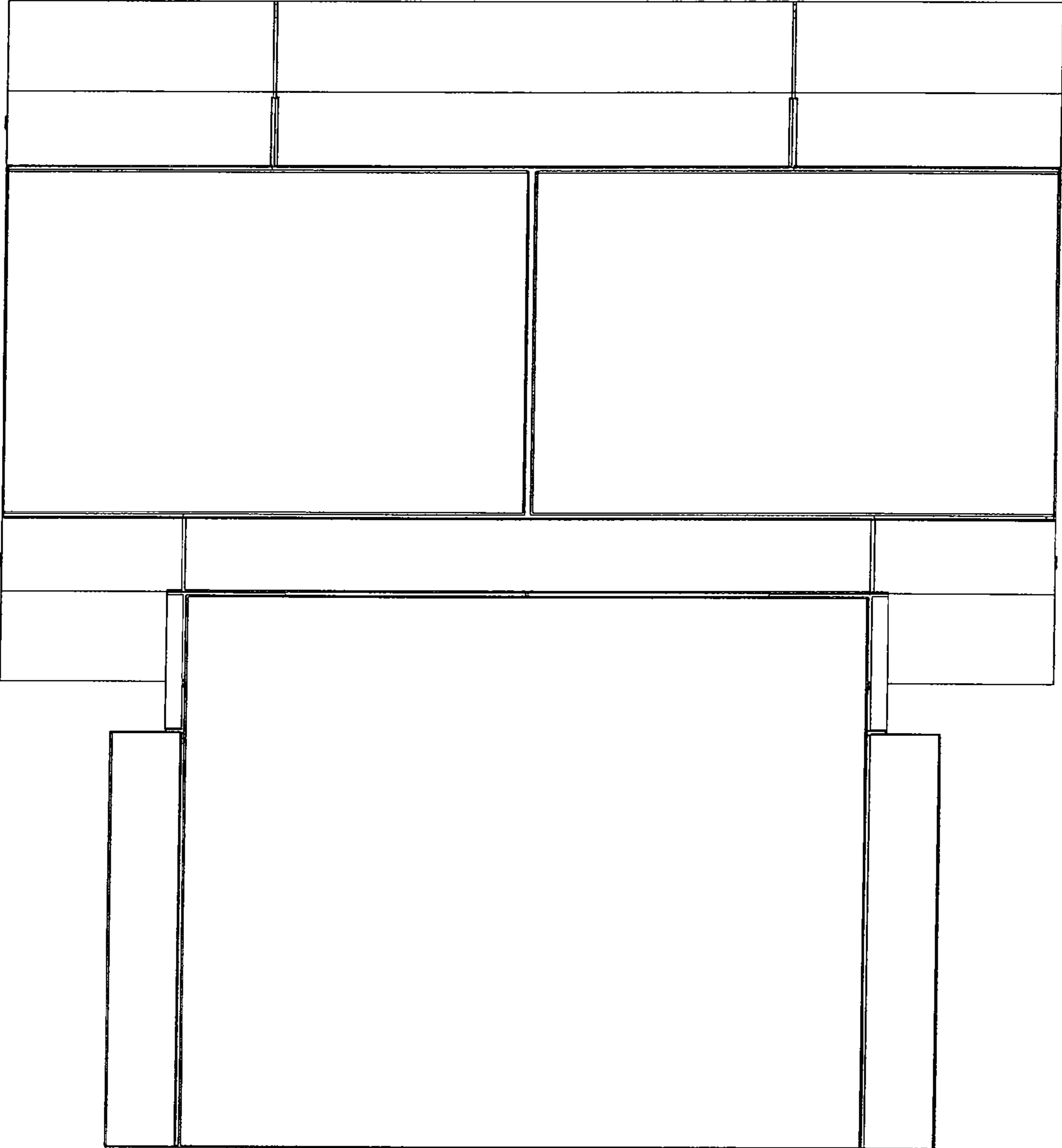

FIG. 3

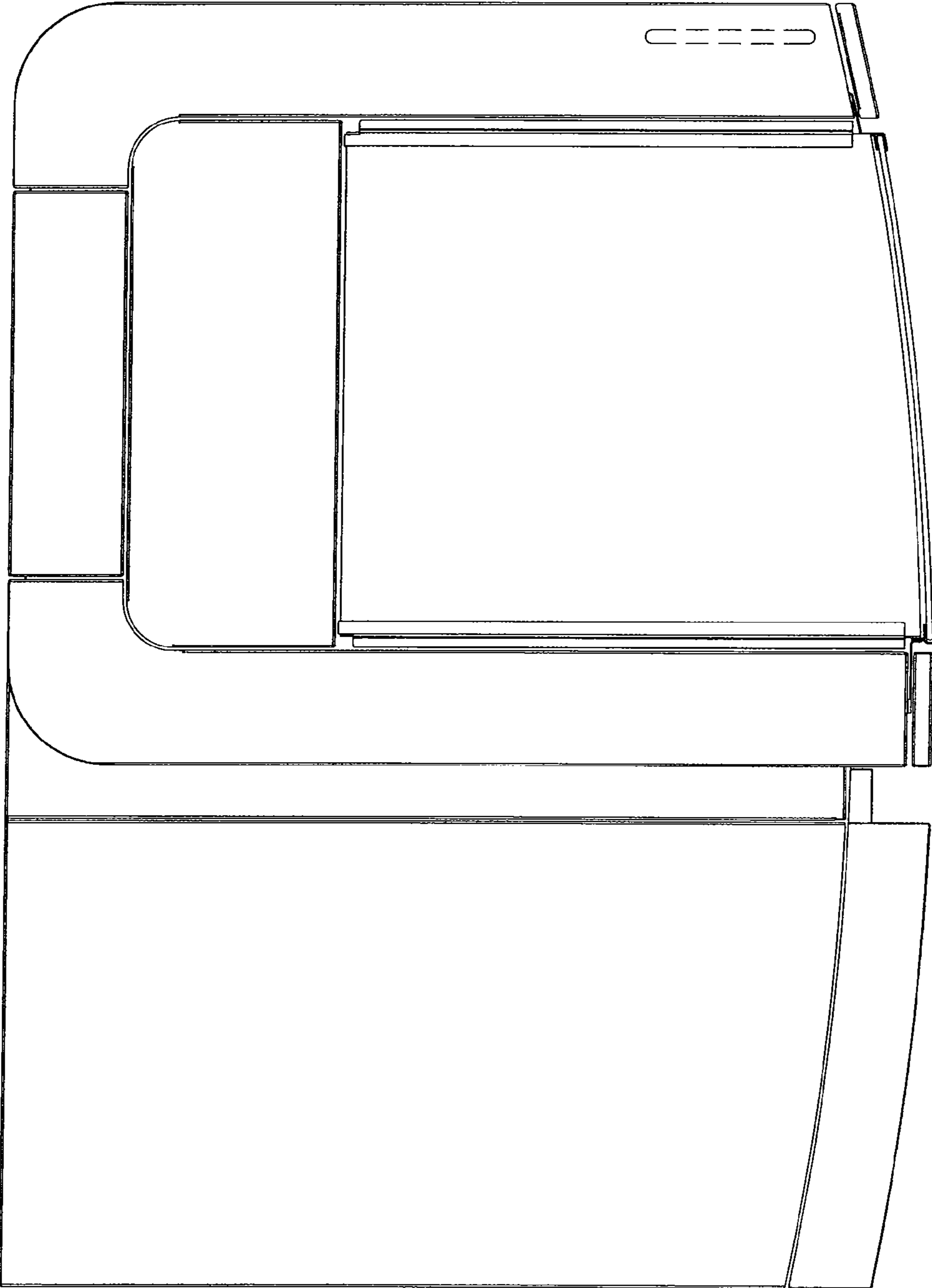

FIG.4

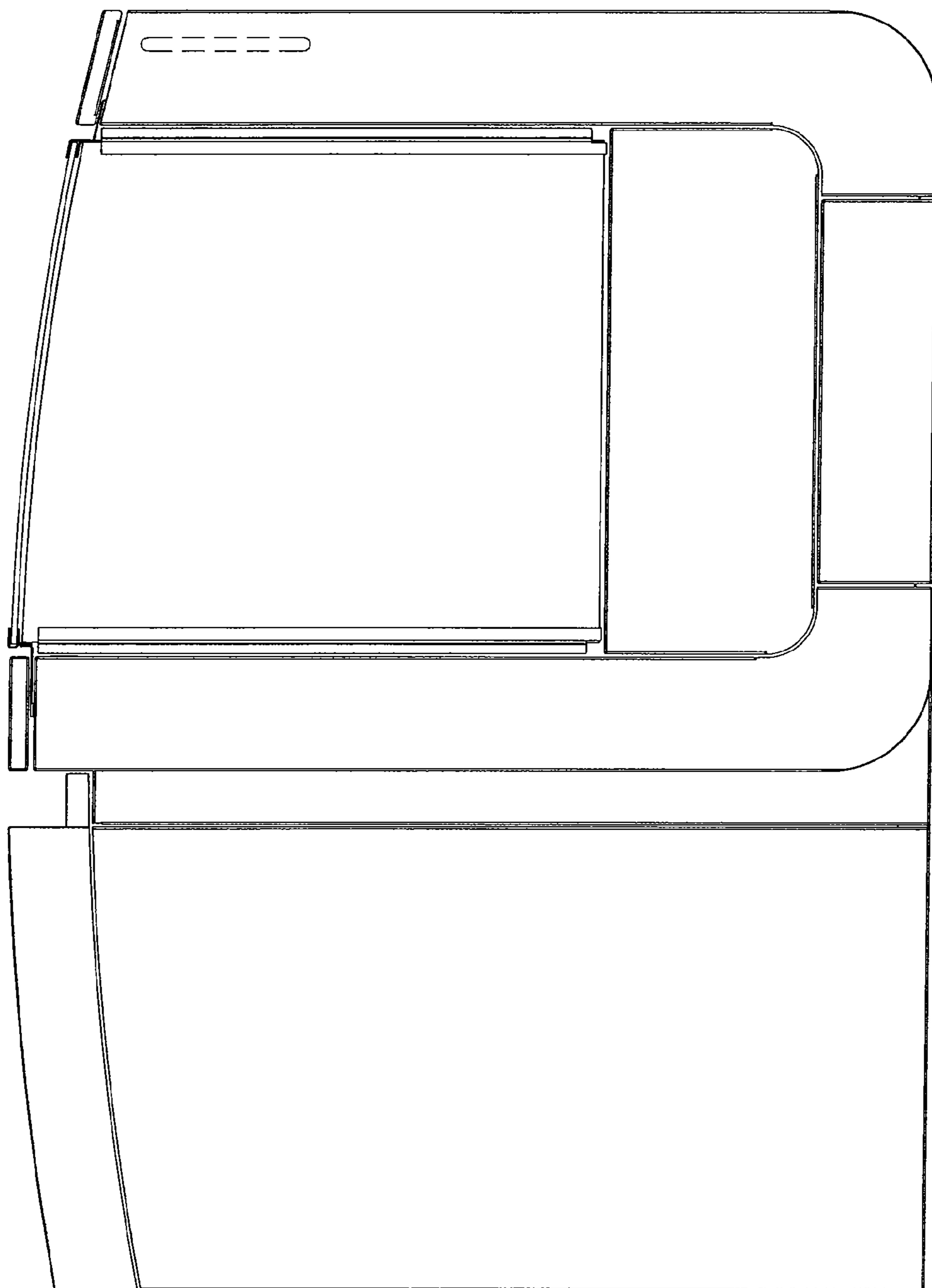

FIG.5

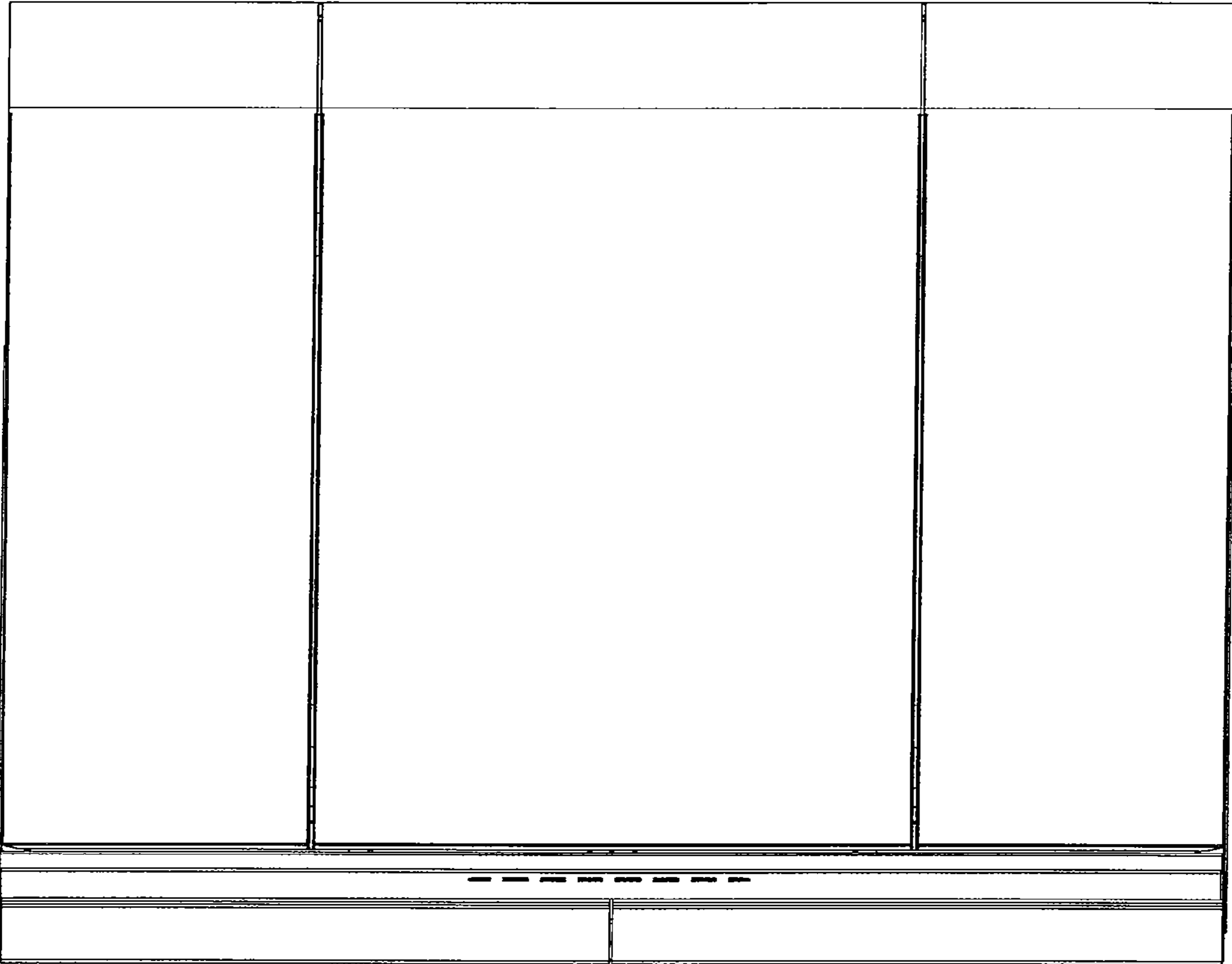

FIG. 6