



US00D600445S

(12) **United States Design Patent**
Rodriguez

(10) **Patent No.:** **US D600,445 S**

(45) **Date of Patent:** **** Sep. 22, 2009**

(54) **CLAMSHELL SUITCASE**

2002/0074251 A1* 6/2002 Hirshberg 206/315.1

(75) Inventor: **Anthony V. Rodriguez**, Andover, NJ
(US)

OTHER PUBLICATIONS

(73) Assignee: **Randa Luggage, Inc.**, Totowa, NJ (US)

Nautical Clamshell Collection. Downloaded Jan. 17, 2009 at <http://www.randaluggage.com/brand-collection.asp?id=nautica>.*

(**) Term: **14 Years**

* cited by examiner

(21) Appl. No.: **29/318,601**

Primary Examiner—Philip S Hyder
Assistant Examiner—Roselynn Cody

(22) Filed: **May 22, 2008**

(74) *Attorney, Agent, or Firm*—Caesar, Rivise, Bernstein, Cohen & Pokotilow, Ltd.

(51) **LOC (9) Cl.** **03-01**

(52) **U.S. Cl.** **D3/283; D3/289; D3/902**

(58) **Field of Classification Search** D3/232,
D3/233, 276, 283, 289, 902; 150/161–162,
150/165, 901; 190/100, 103–104, 107, 109,
190/111–113, 115–116, 119, 903

(57) **CLAIM**

See application file for complete search history.

The ornamental design for the clamshell suitcase, as shown and described.

DESCRIPTION

(56) **References Cited**

U.S. PATENT DOCUMENTS

D231,042 S *	3/1974	Lee	D3/289
3,830,348 A	8/1974	Ohyama		
D264,146 S *	5/1982	Davis	D3/287
D278,763 S *	5/1985	Allen	D3/283
D282,602 S	2/1986	Allen		
4,805,749 A *	2/1989	Gerch	190/111
D301,086 S *	5/1989	Hess	D3/283
5,289,906 A	3/1994	Guidi		
5,399,020 A	3/1995	Cheng		
D432,344 S *	10/2000	Eskandry	D6/632
D435,385 S *	12/2000	Eskandry	D6/633
6,334,519 B1 *	1/2002	Tong	190/107
D468,532 S *	1/2003	Hassett	D3/285
6,591,950 B1	7/2003	Scicluna		
D509,360 S	9/2005	Cassegrain		
6,966,439 B2	11/2005	Weleccki		
D527,521 S *	9/2006	Sijmons	D3/289
D530,915 S *	10/2006	Sijmons	D3/289
7,207,426 B2 *	4/2007	Godshaw et al.	190/1
D547,058 S *	7/2007	Power	D3/232

FIG. 1 is a front elevation view of a clamshell suitcase in accordance with a preferred embodiment of my design, shown in an open for use configuration;

FIG. 2 is a left side view of the clamshell suitcase of FIG. 1;

FIG. 3 is a right side view of the clamshell suitcase of FIG. 1;

FIG. 4 is a top plan view of the clamshell suitcase of FIG. 1;

FIG. 5 is a rear elevation view of the clamshell suitcase of FIG. 1;

FIG. 6 is a bottom view of the clamshell suitcase of FIG. 1;

FIG. 7 is a front elevation view of the clamshell suitcase of FIG. 1, shown in a partially folded configuration;

FIG. 8 is an isometric view of the clamshell suitcase of FIG. 1, shown with the suitcase in a partially folded configuration;

FIG. 9 is a front elevation view of the clamshell suitcase of FIG. 1, shown in a storage configuration with its fabric body zipped into its shell side pieces;

FIG. 10 is a rear elevation view of the clamshell suitcase of FIG. 1, shown in the storage configuration of FIG. 9;

FIG. 11 is a top plan view of the clamshell suitcase of FIG. 1, shown in the storage configuration of FIG. 9;

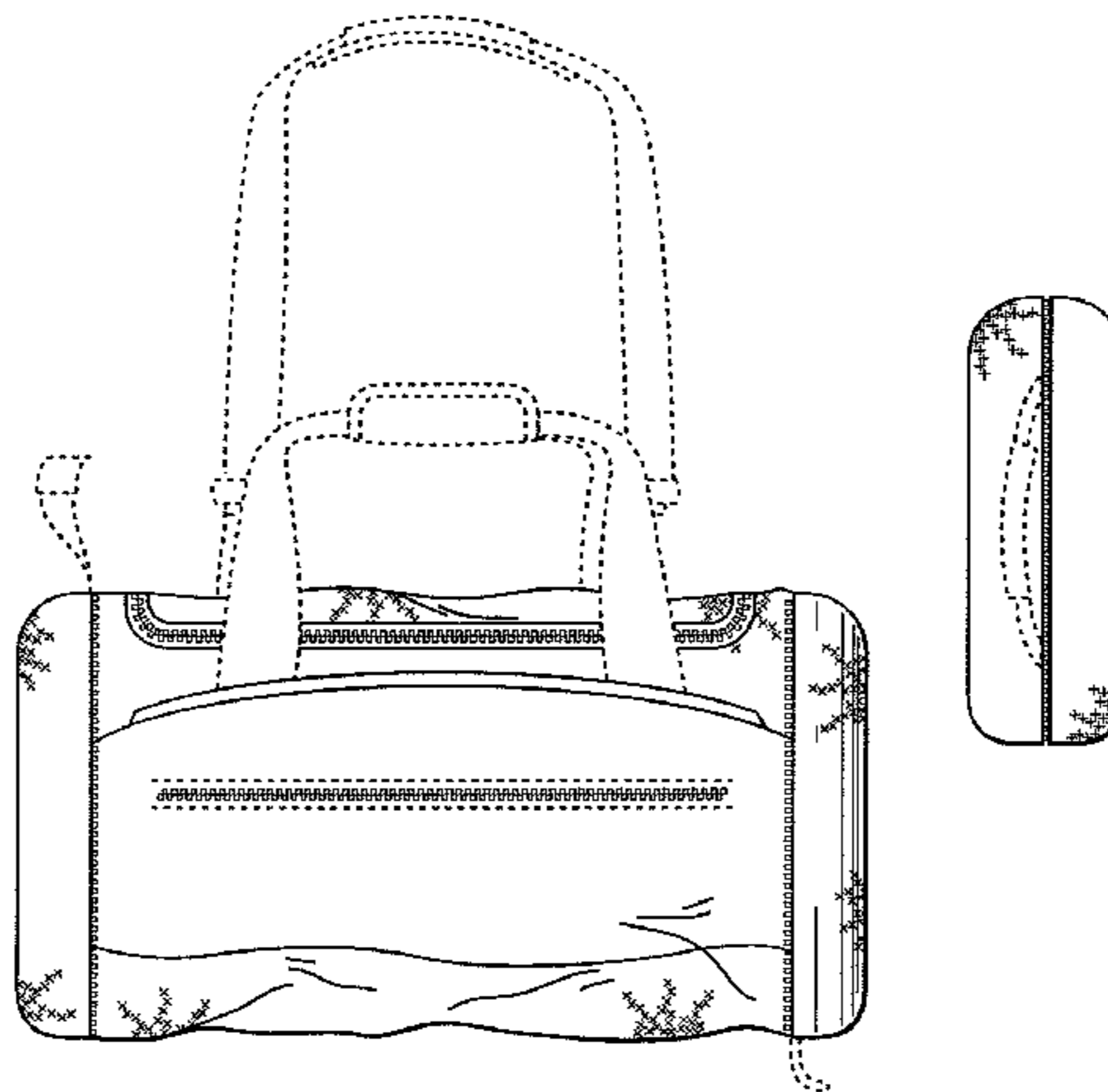

FIG. 12 is a left side view of the clamshell suitcase of FIG. 1, shown in the storage configuration of FIG. 9, the right side view being the mirror image thereof;

FIG. 13 is a bottom view of the clamshell suitcase of FIG. 1, shown in the storage configuration of FIG. 9;

FIG. 14 is a front elevation view of a clamshell suitcase in accordance with a second preferred embodiment of my design, shown in an open for use configuration;

FIG. 15 is a left side view of the clamshell suitcase of FIG. 14;

FIG. 16 is a right side view of the clamshell suitcase of FIG. 14;

FIG. 17 is a top plan view of the clamshell suitcase of FIG. 14;

FIG. 18 is a rear elevation view of the clamshell suitcase of FIG. 14;

FIG. 19 is a bottom view of the clamshell suitcase of FIG. 14;

FIG. 20 is an isometric view of the clamshell suitcase of FIG. 14, shown with the suitcase in a partially folded configuration;

FIG. 21 is a front elevation view of the clamshell suitcase of FIG. 14, shown in a partially folded configuration;

FIG. 22 is a front elevation view of the clamshell suitcase of FIG. 14, shown in a storage configuration with its fabric body zipped into its shell side pieces;

FIG. 23 is a rear elevation view of the clamshell suitcase of FIG. 14, shown in the storage configuration of FIG. 22;

FIG. 24 is a top plan view of the clamshell suitcase of FIG. 14, shown in the storage configuration of FIG. 22;

FIG. 25 is a left side view of the clamshell suitcase of FIG. 14, shown in the storage configuration of FIG. 22, the right side view being the mirror image thereof, and,

FIG. 26 is a bottom view of the clamshell suitcase of FIG. 14, shown in the storage configuration of FIG. 22.

The dashed lines shown in the figures represent environmental subject matter and form no part of the claimed design.

The cross-hatching is understood to be a pattern or texture—but no particular pattern or texture—that continues throughout the surfaces where it is shown.

1 Claim, 8 Drawing Sheets

FIG. 1

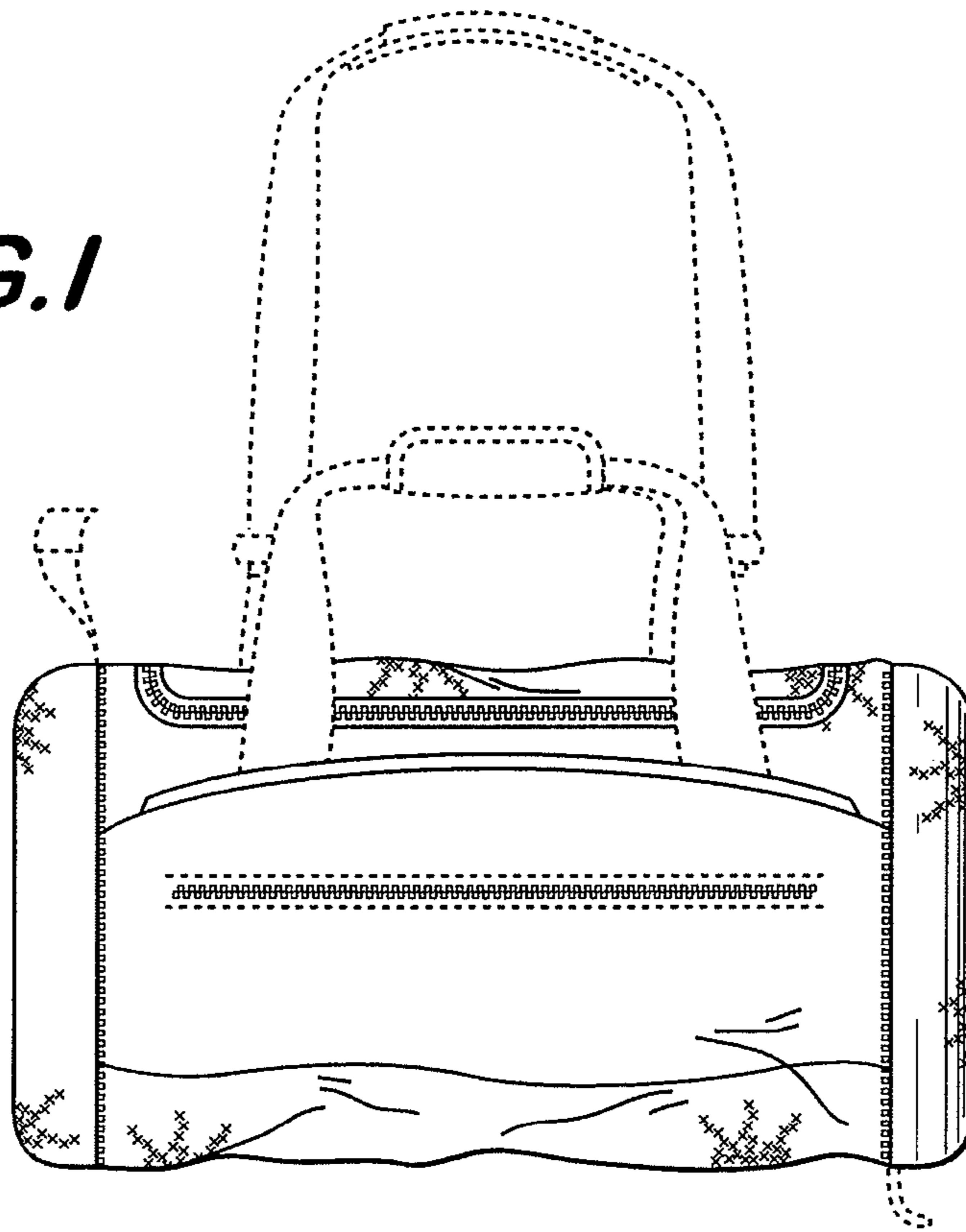

FIG. 2

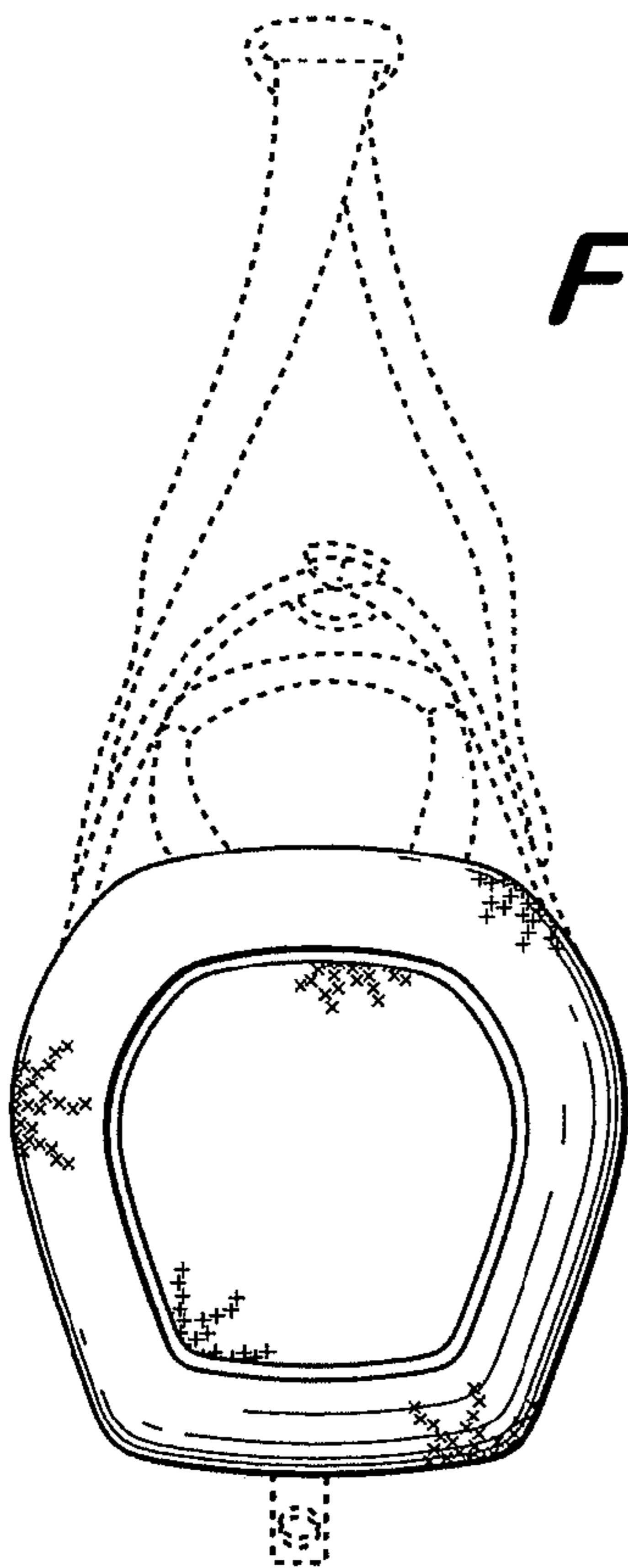

FIG. 3

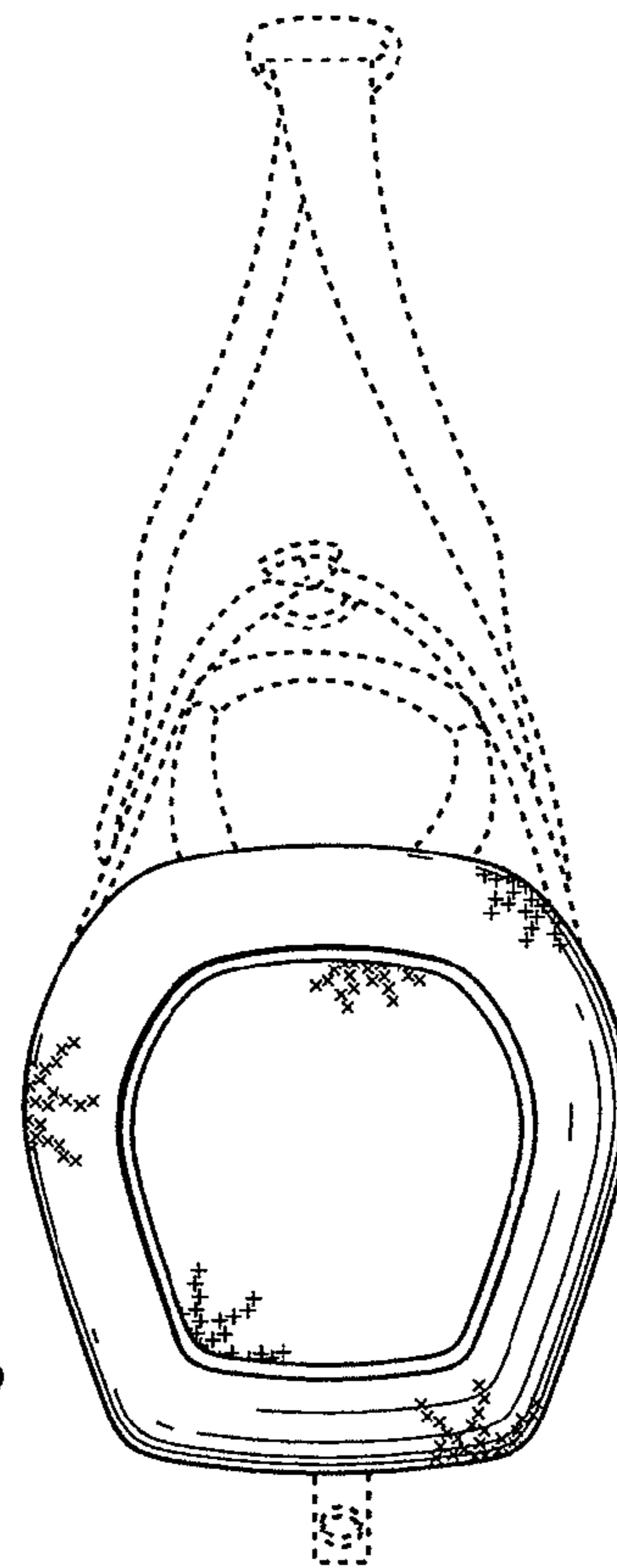

FIG. 4

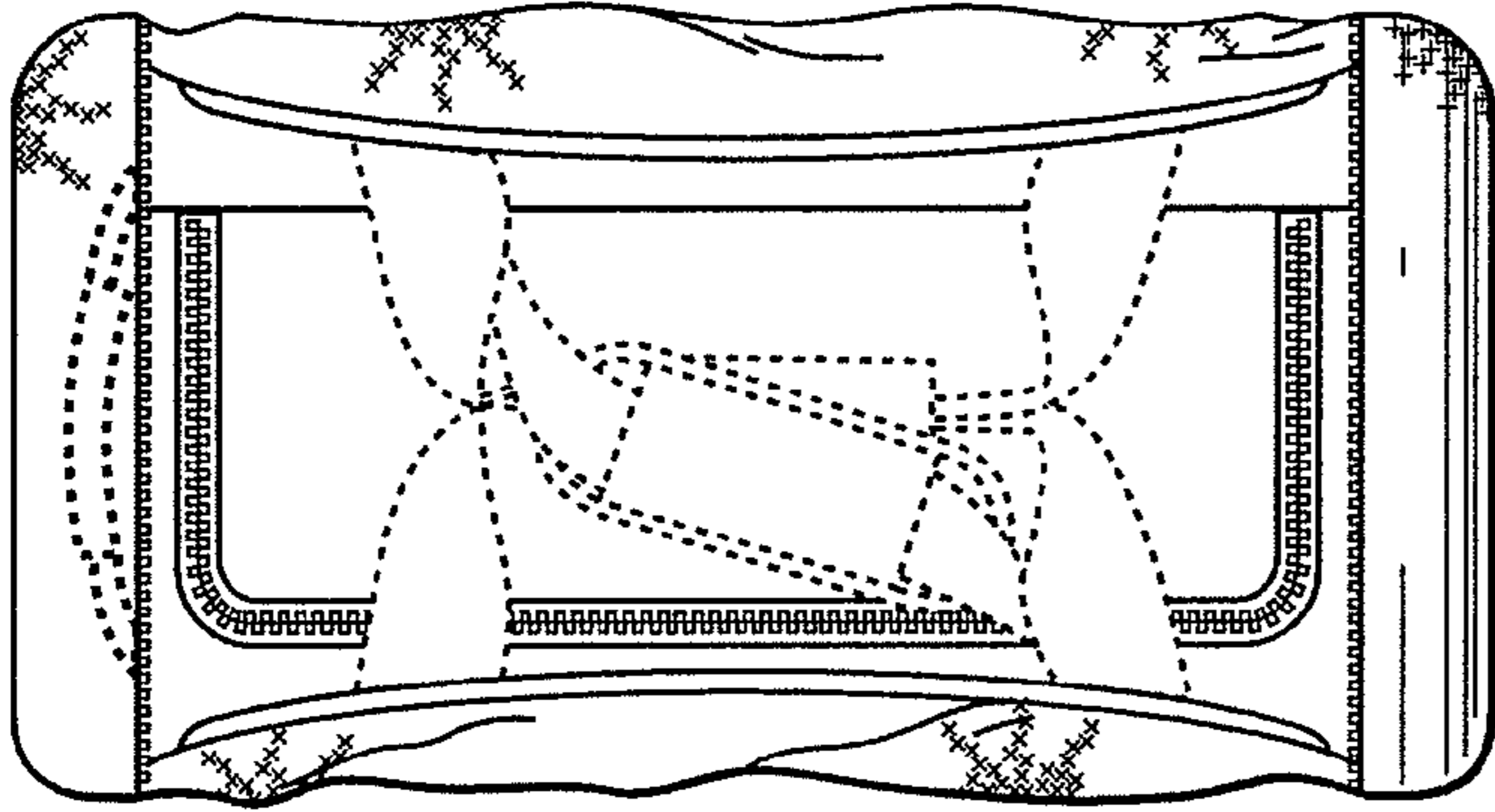

FIG. 5

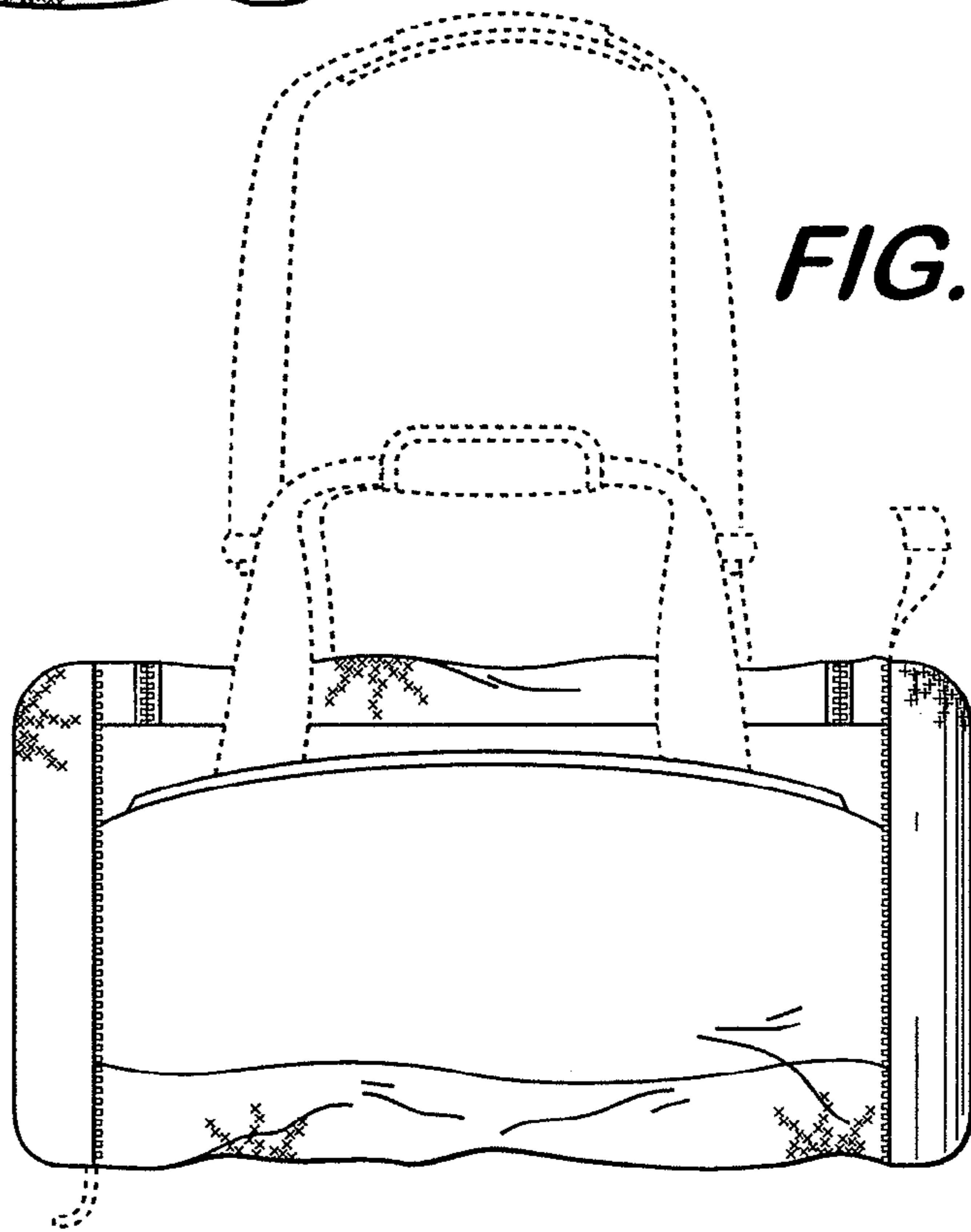
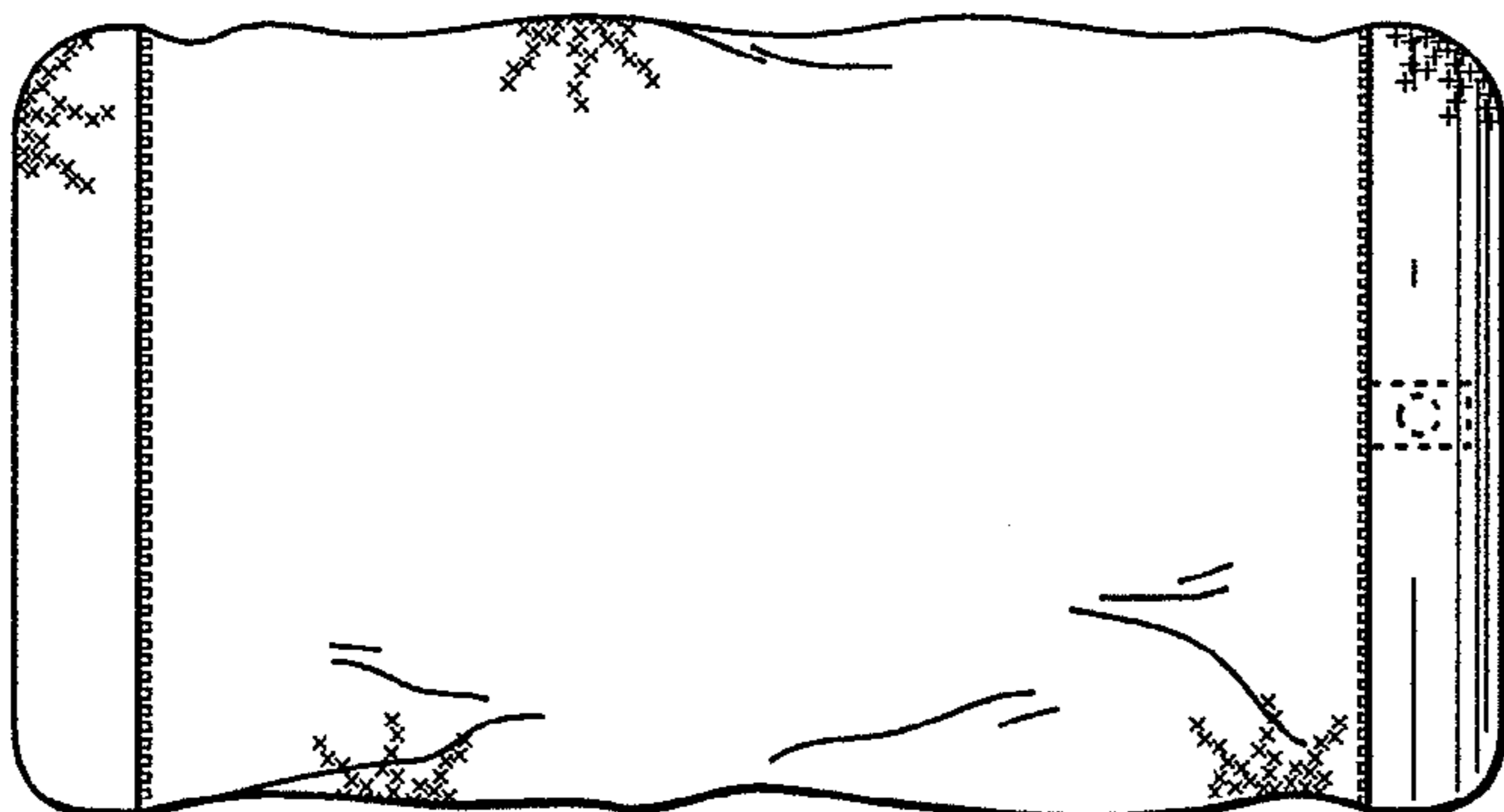

FIG. 6



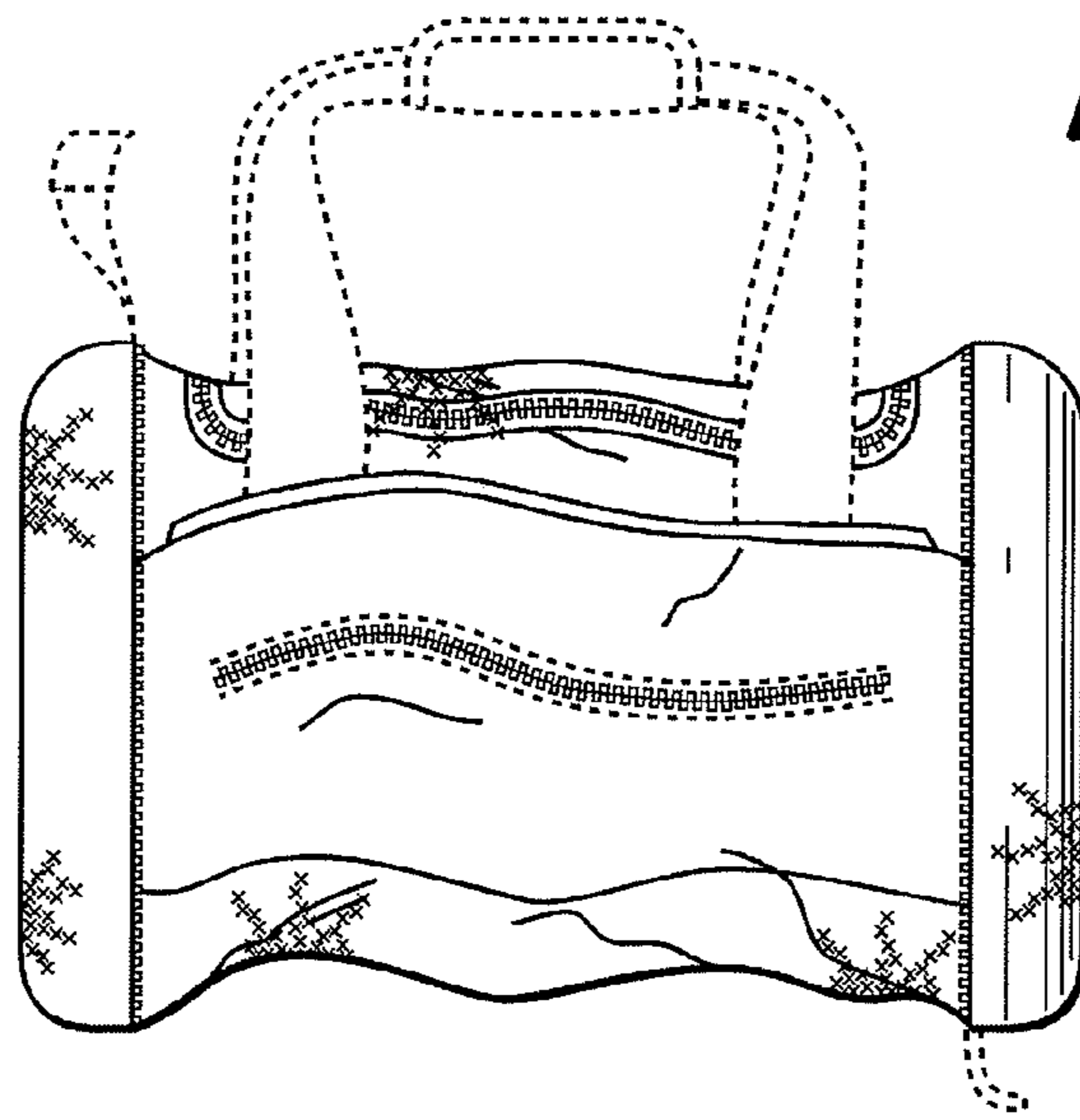

FIG. 7

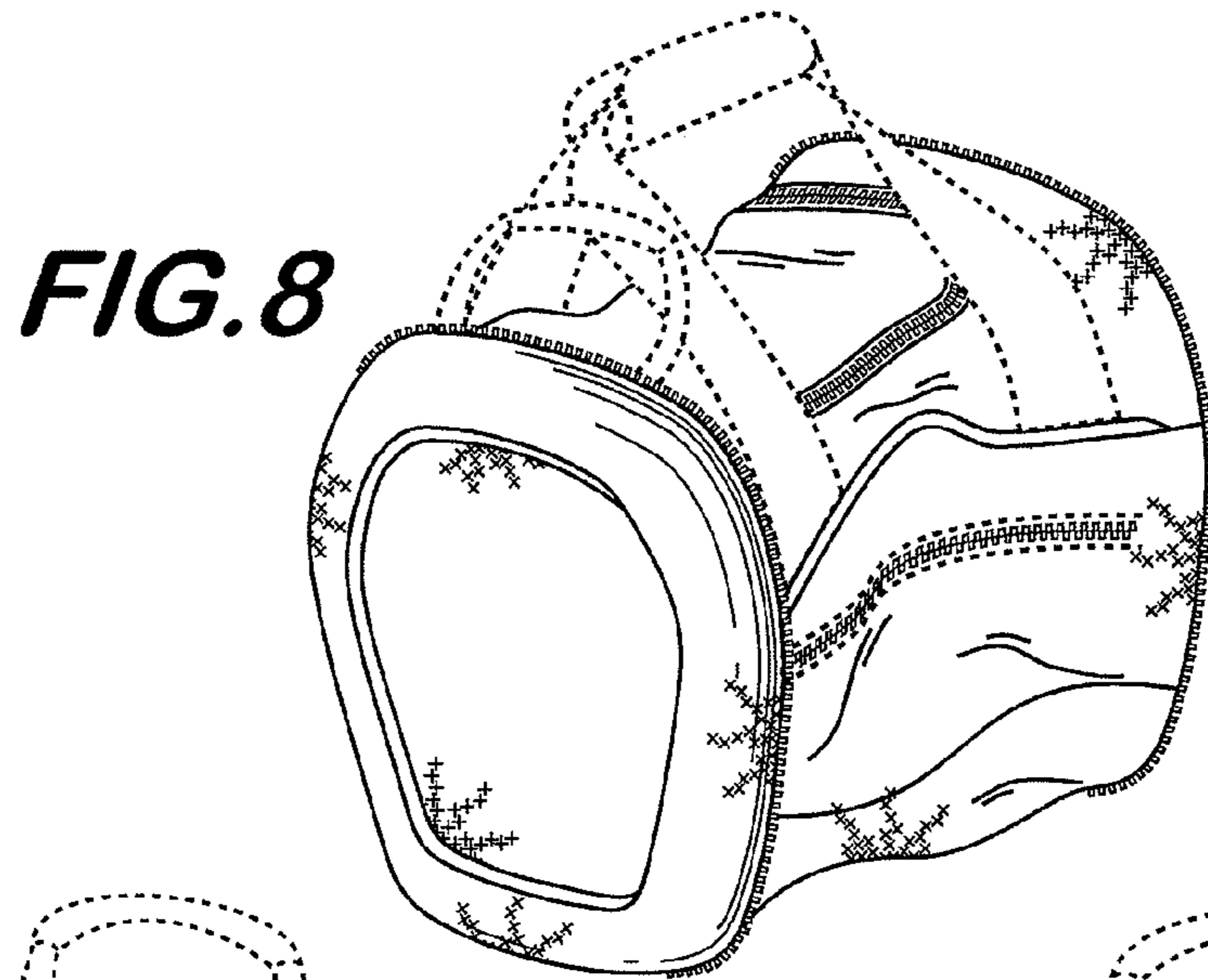

FIG. 8

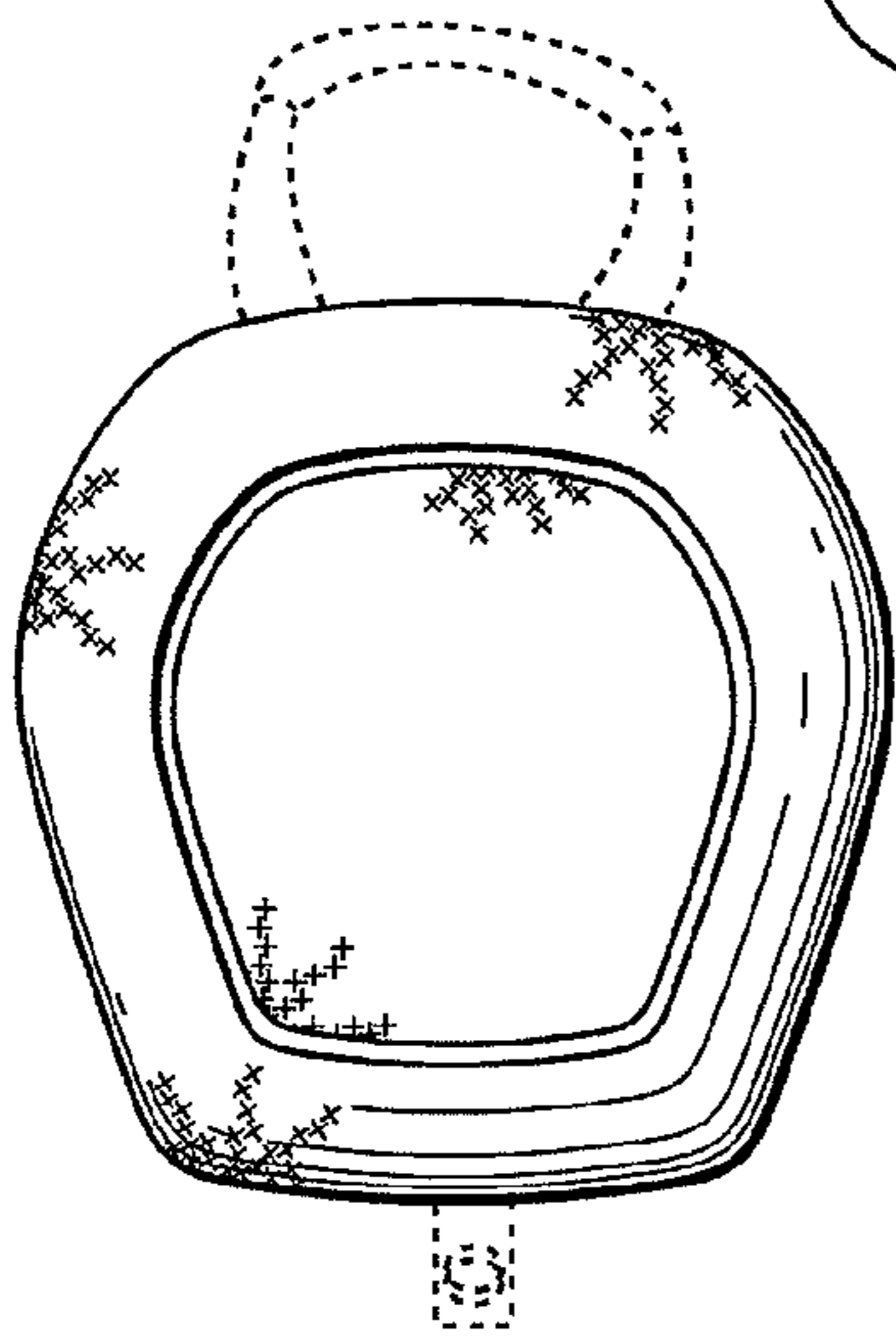

FIG. 9

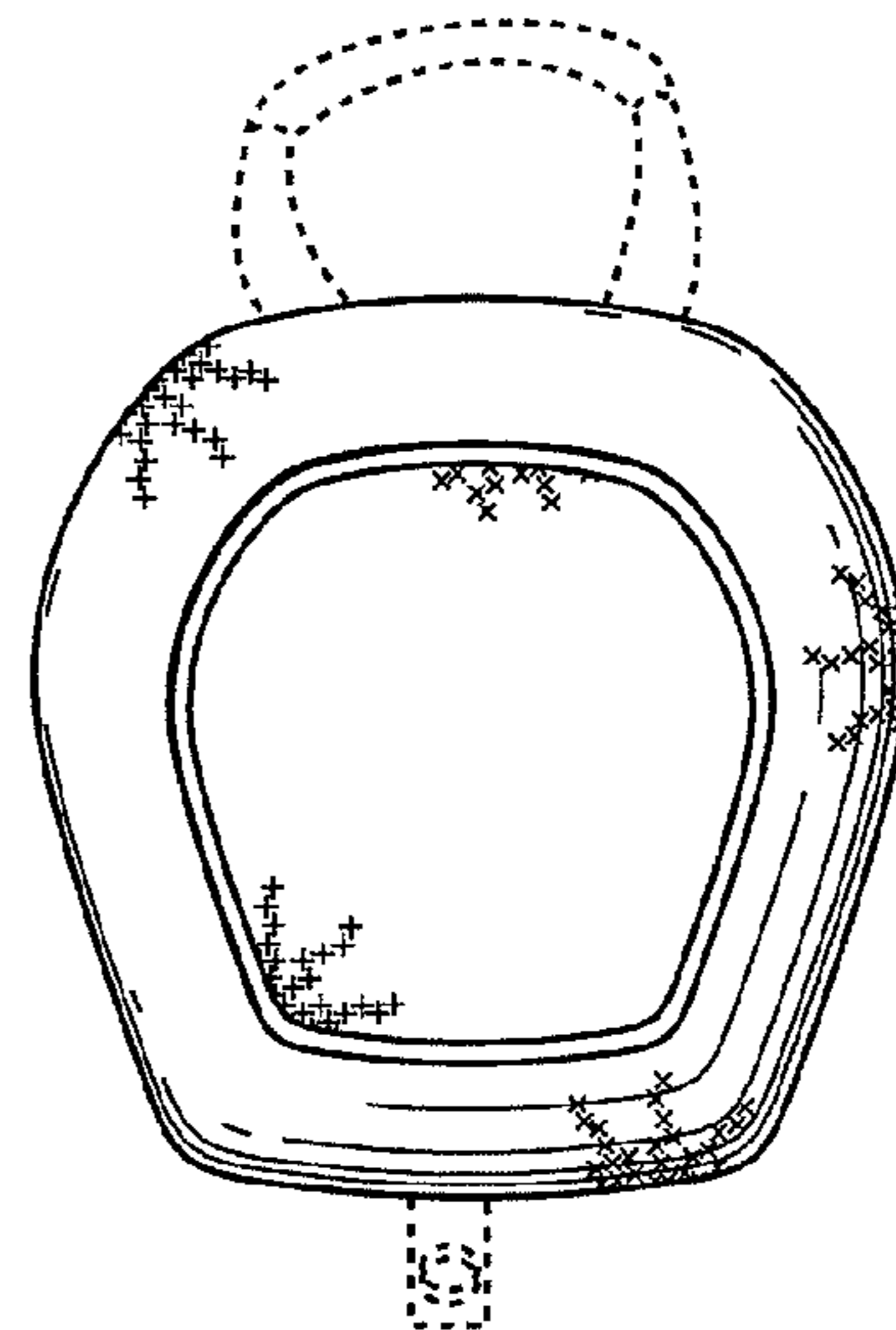

FIG. 10

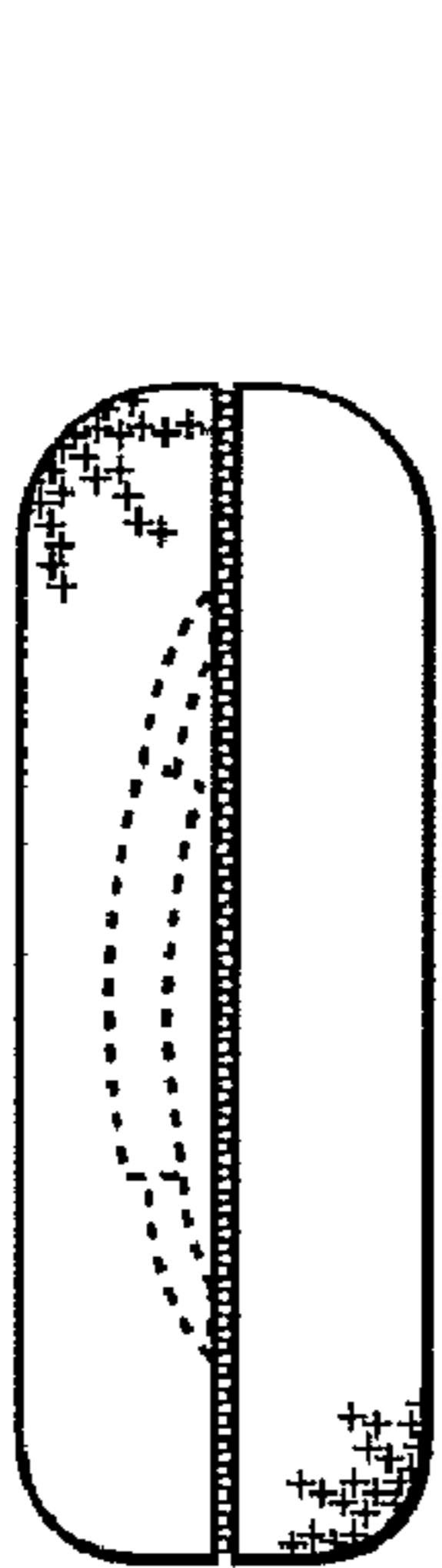

FIG. 11

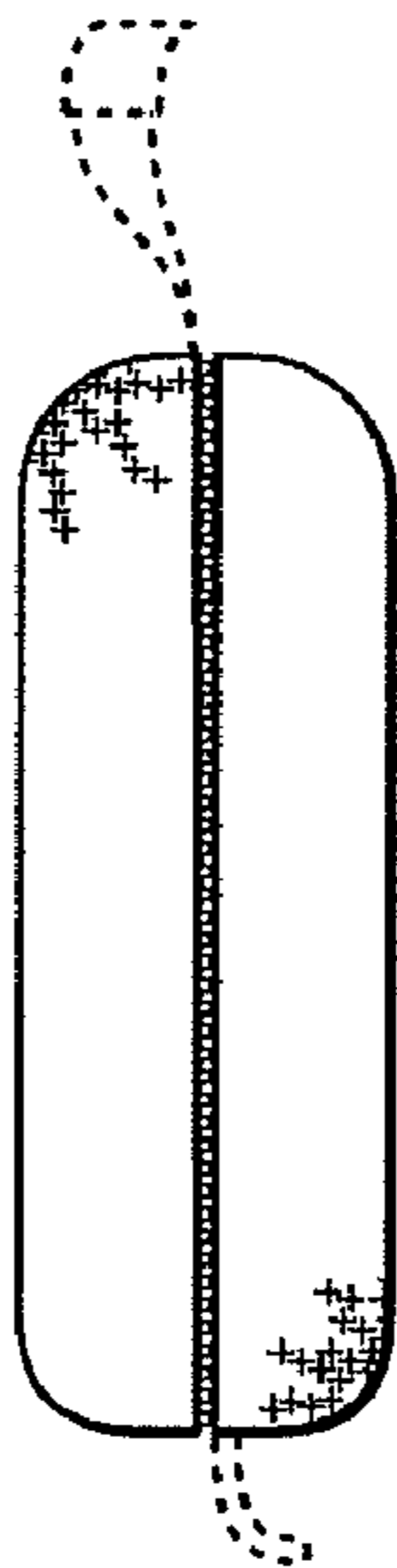

FIG. 12

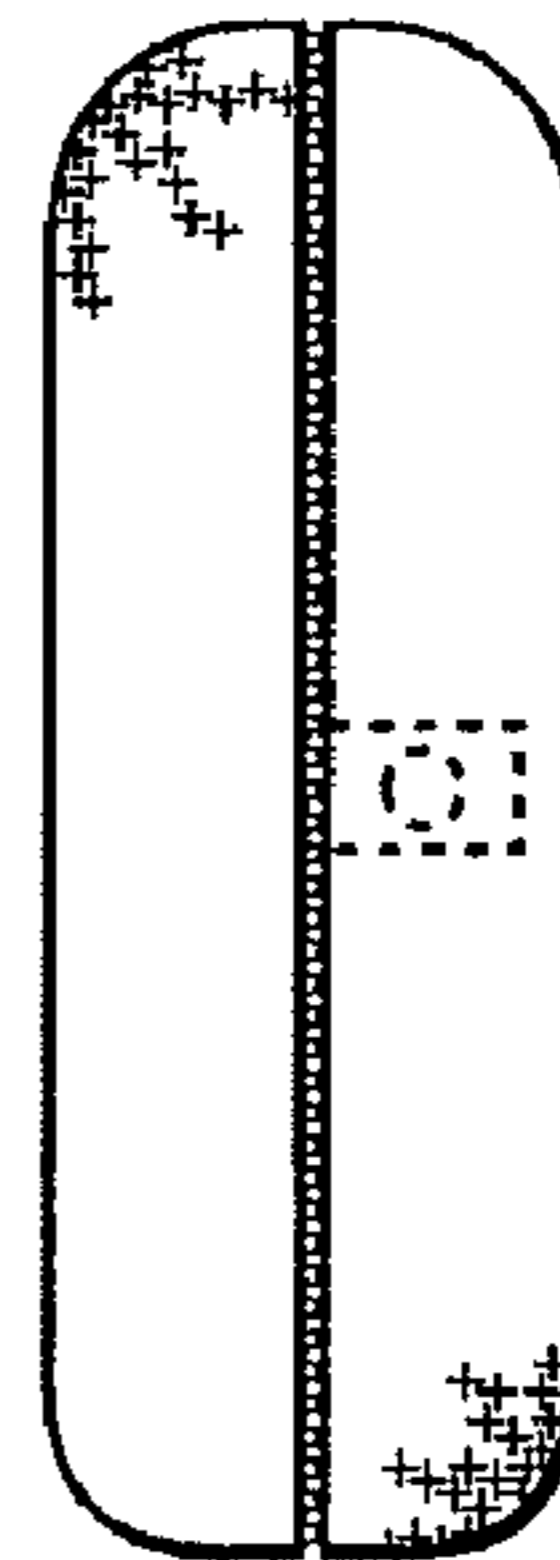

FIG. 13

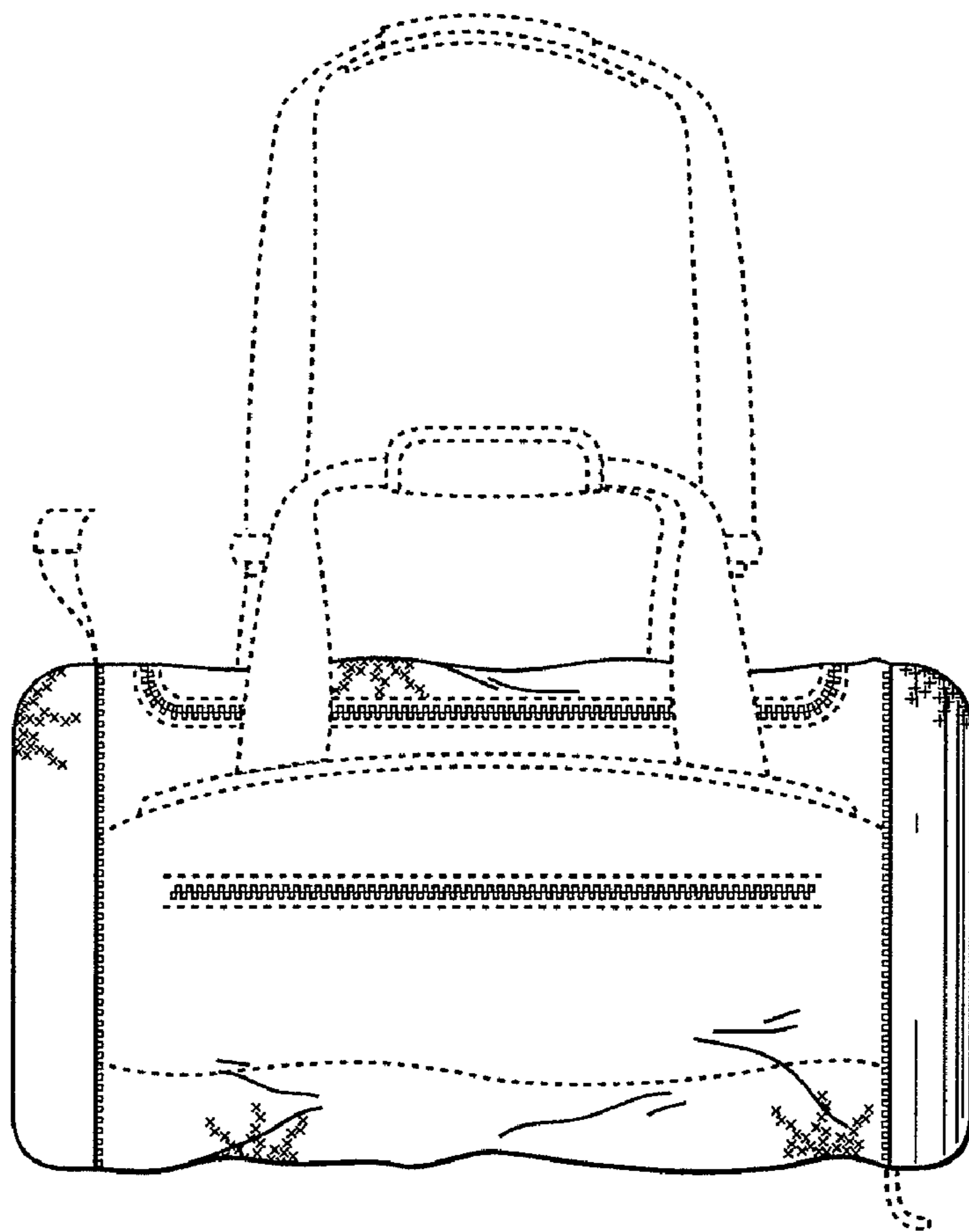

FIG. 14

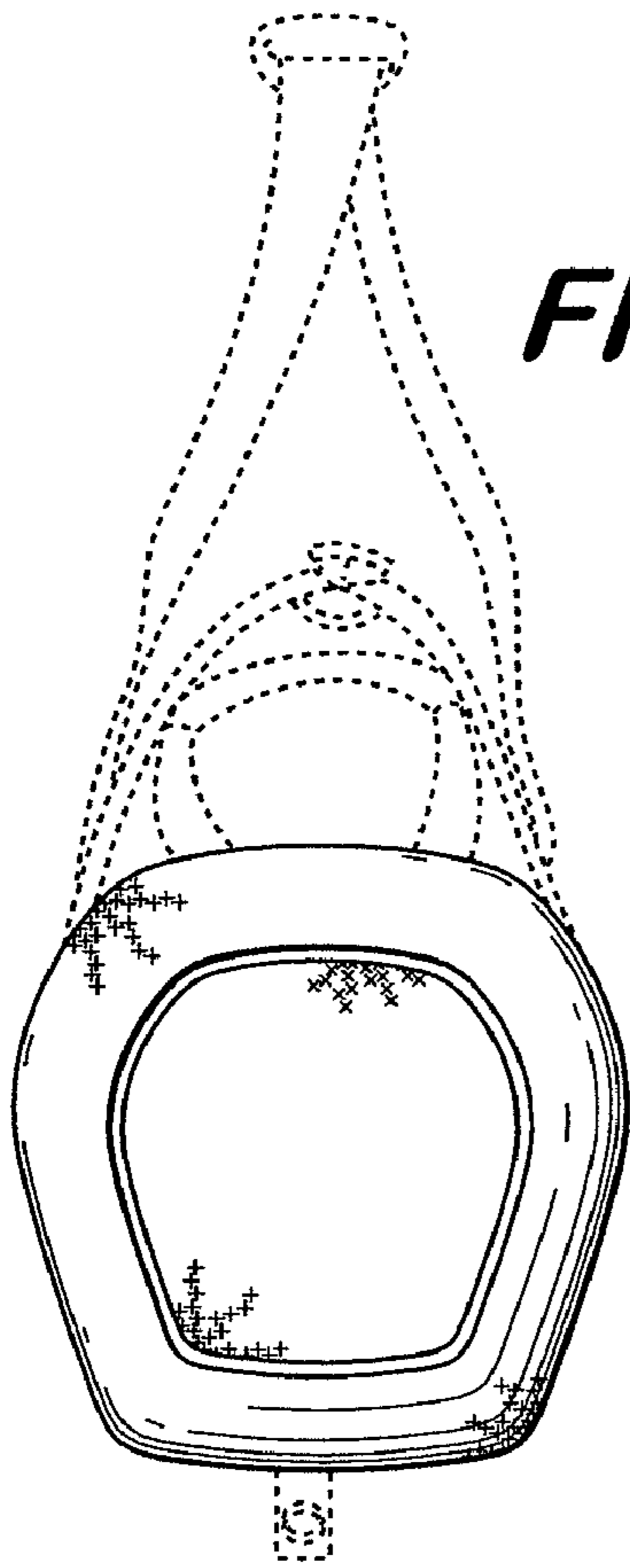

FIG. 15

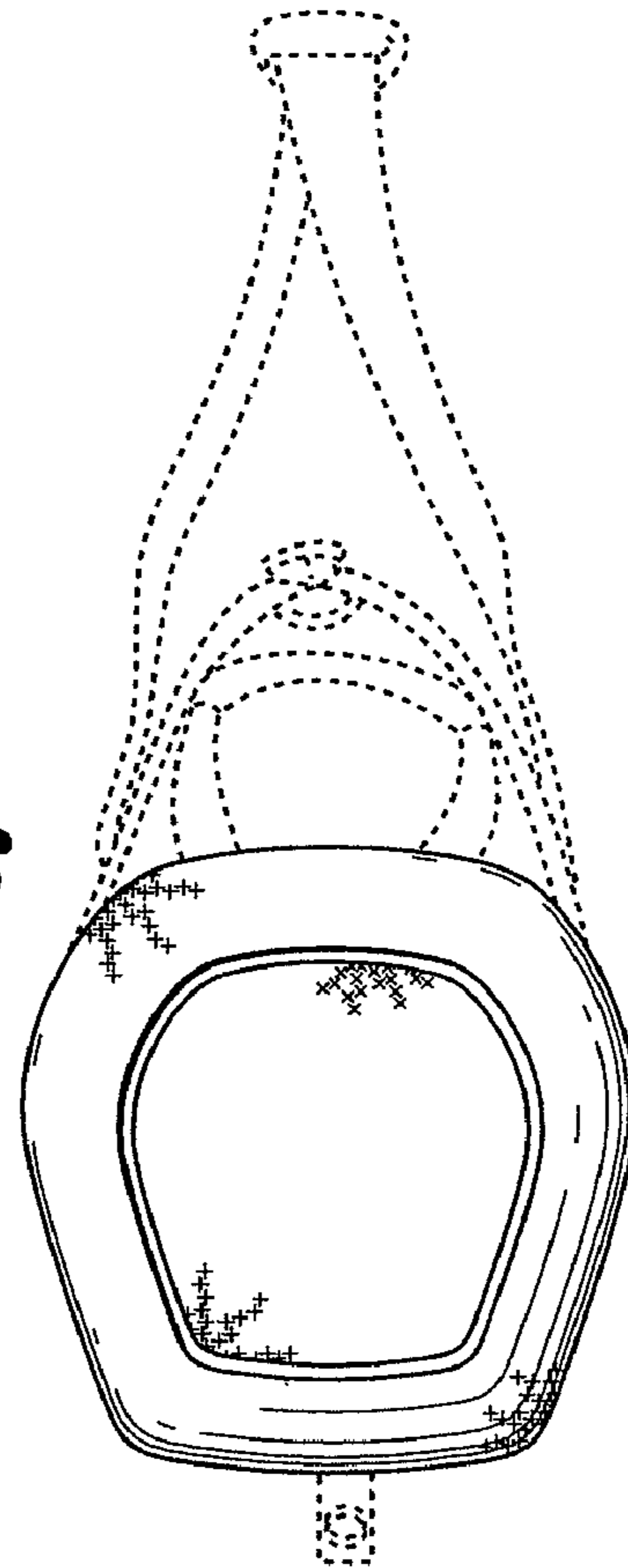

FIG. 16

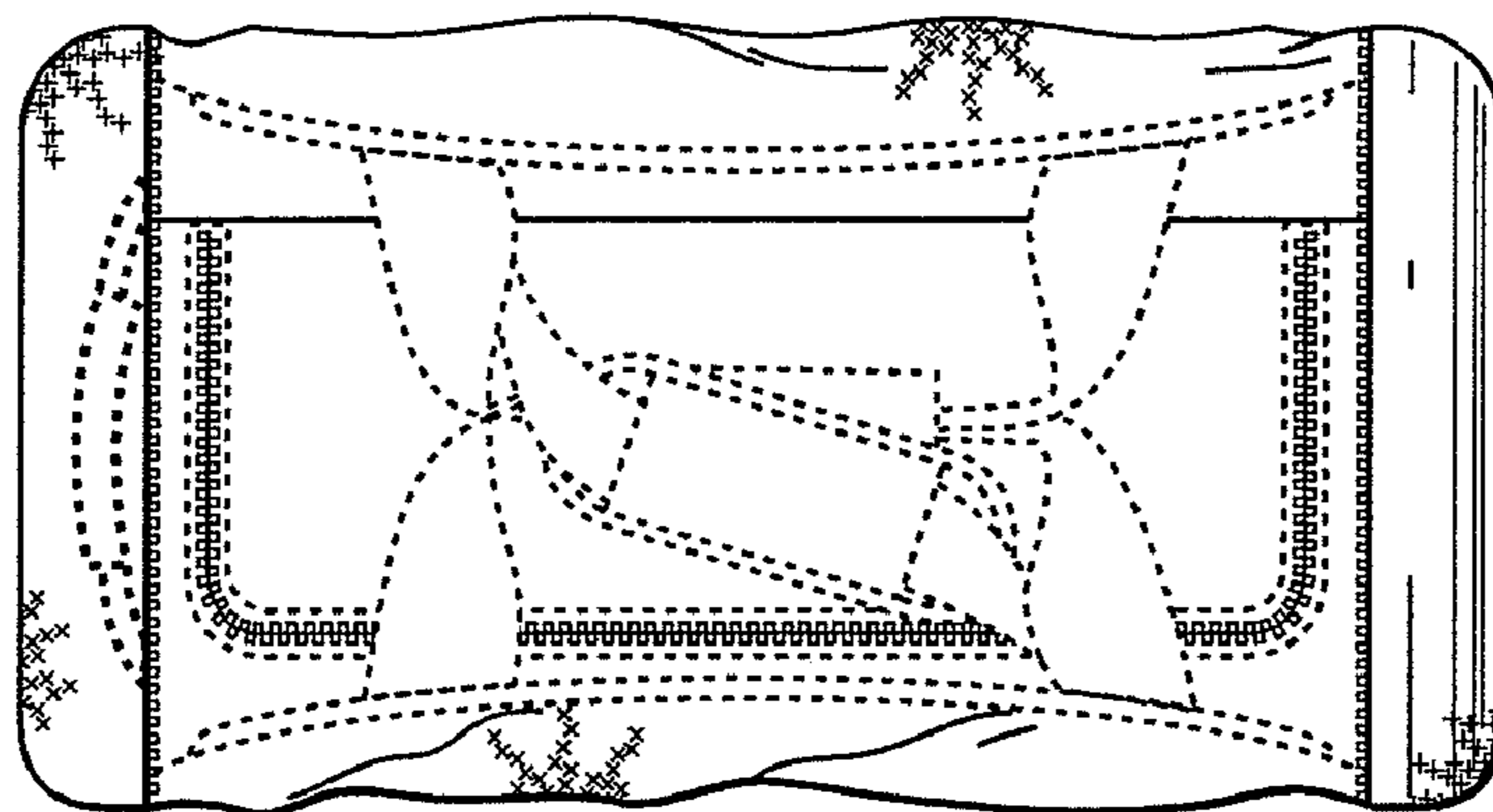

FIG. 17

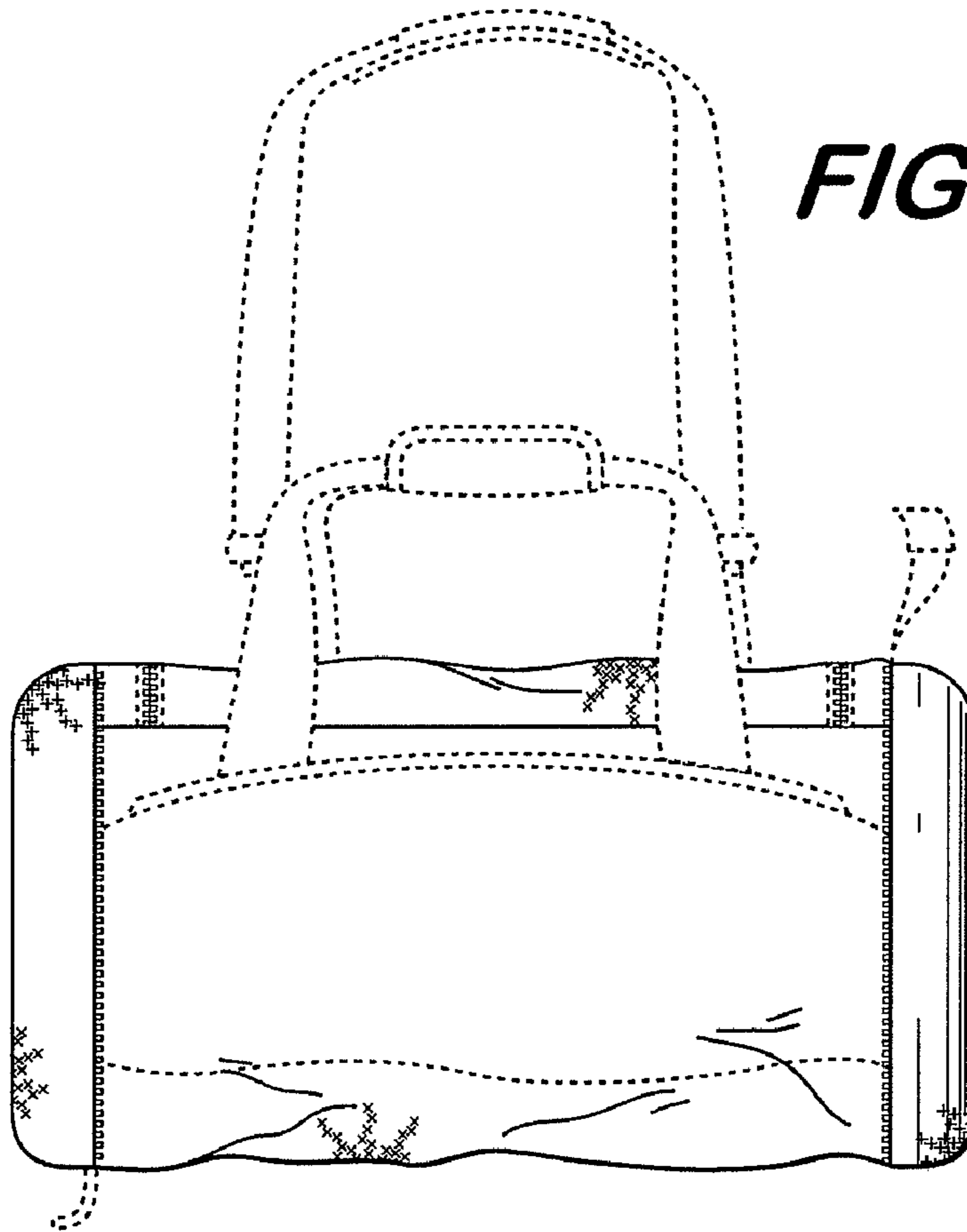

FIG. 18

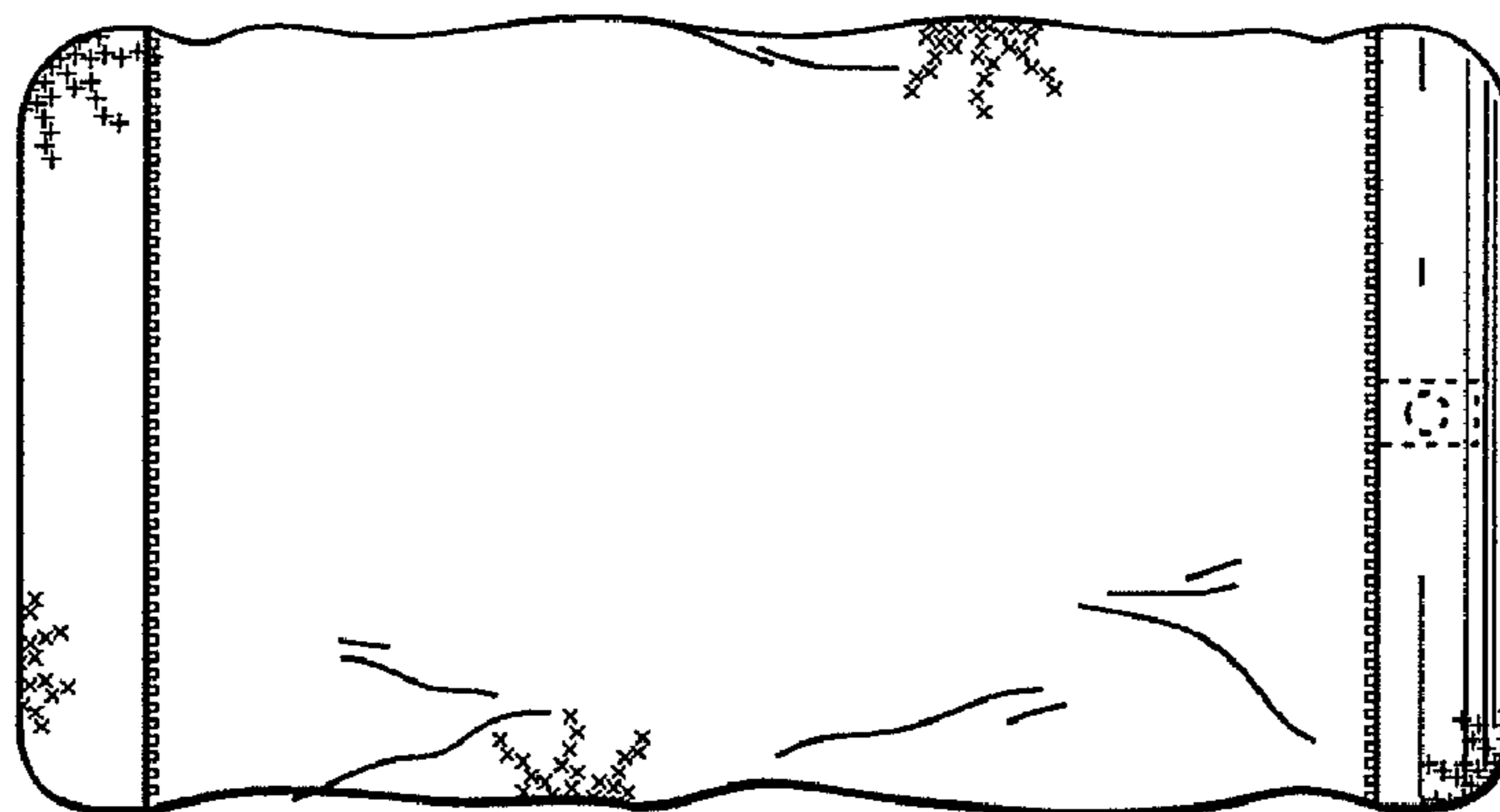

FIG. 19

FIG. 20

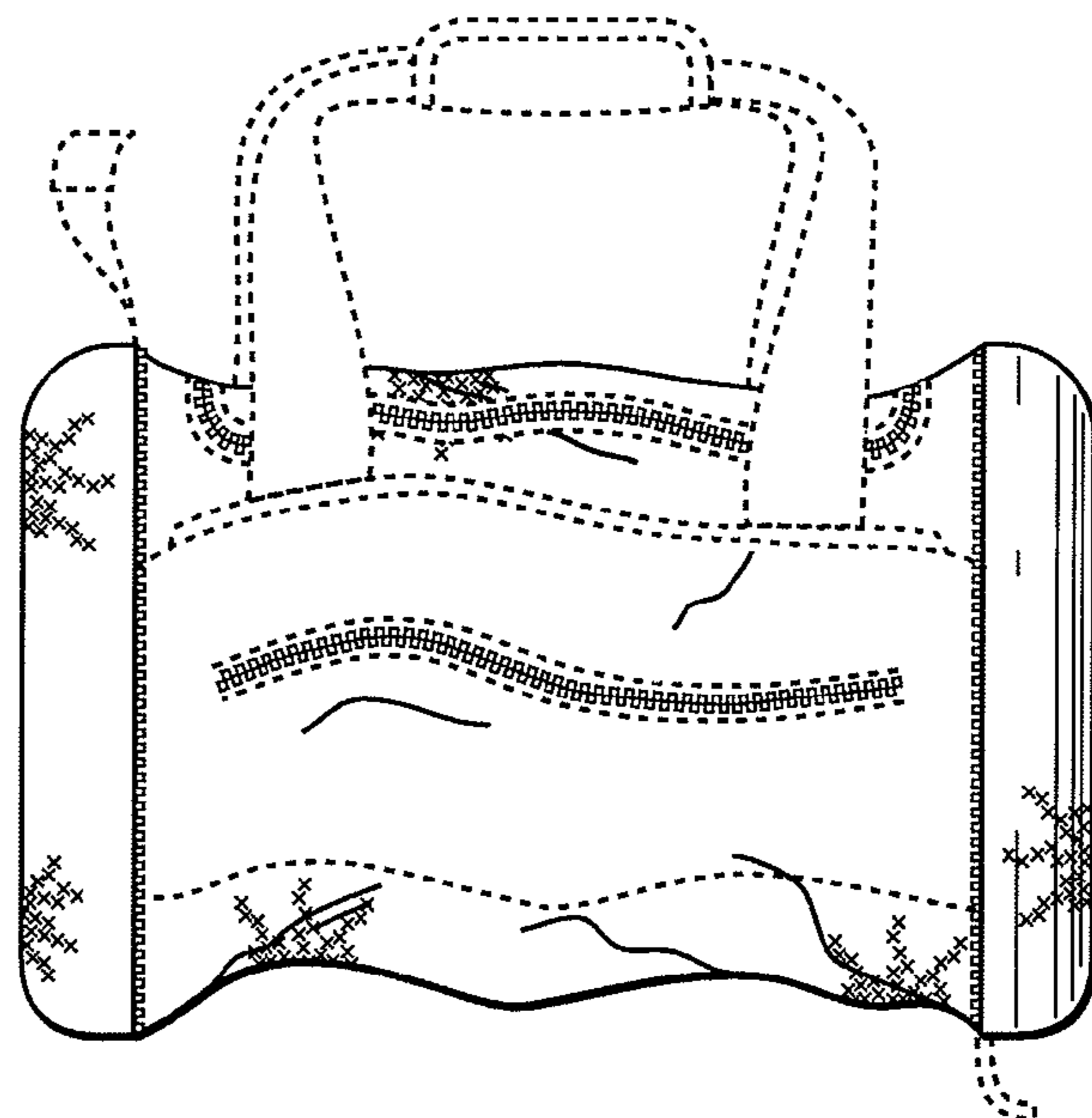
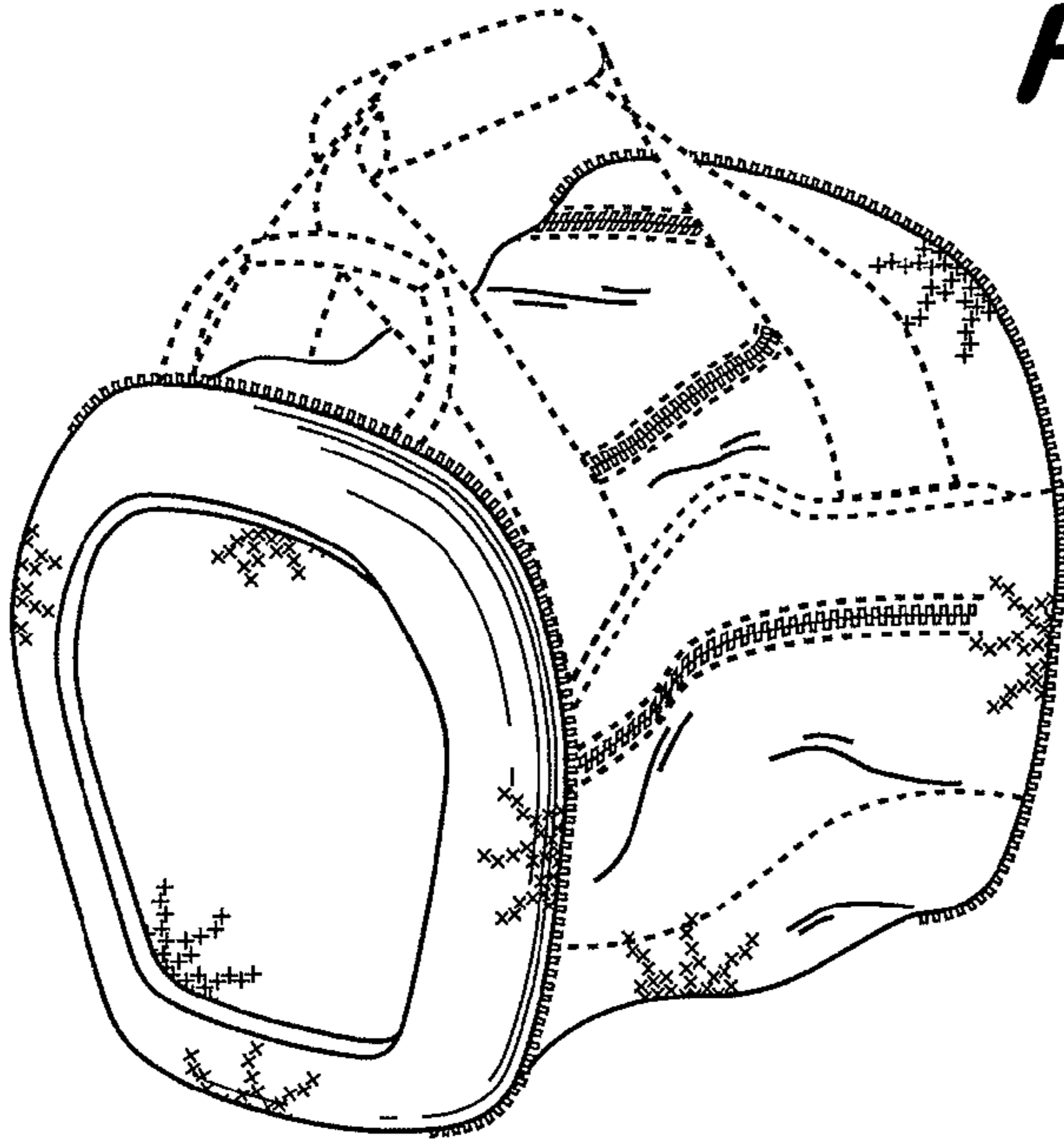

FIG. 21



FIG. 25

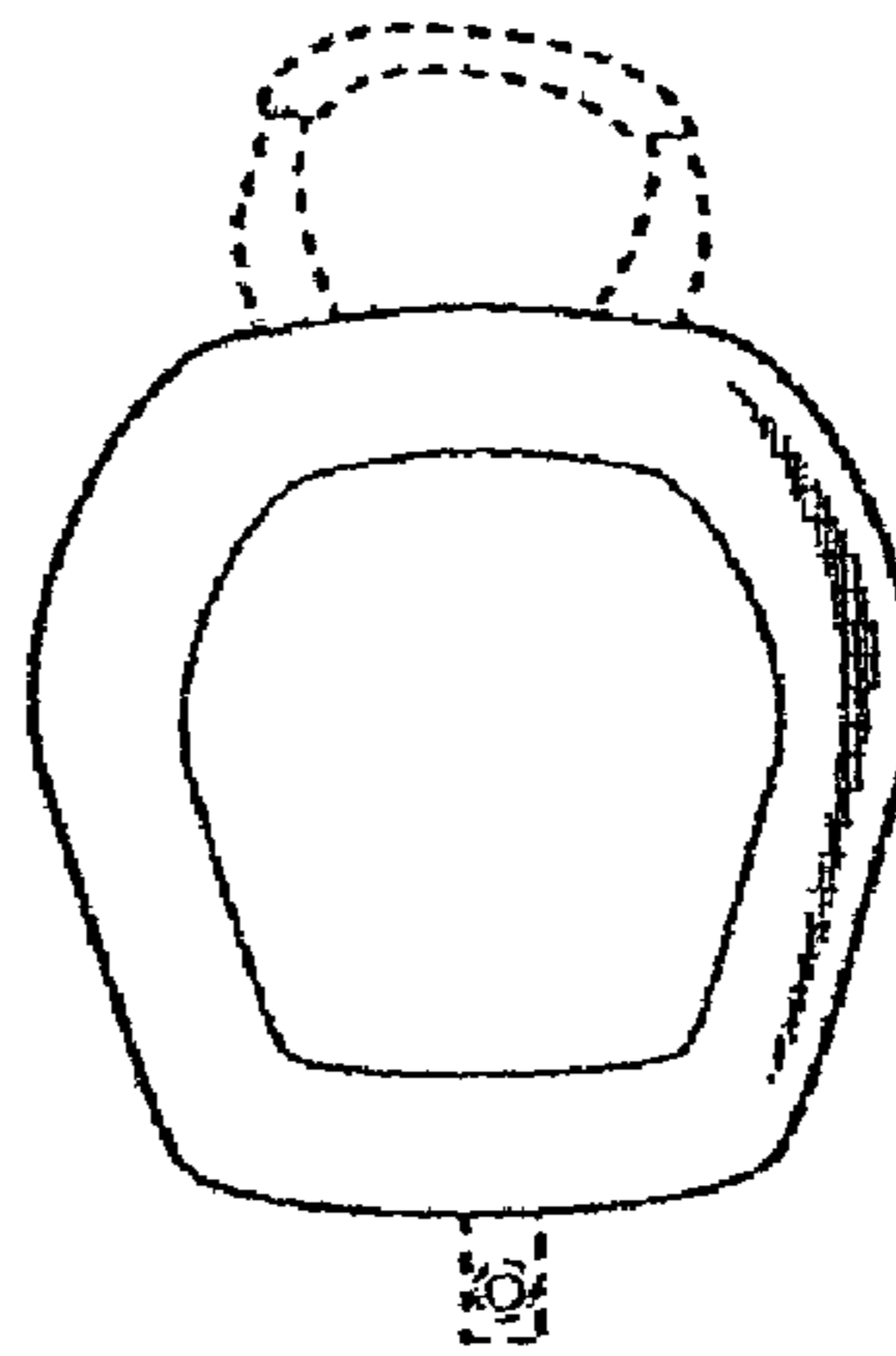

FIG. 22

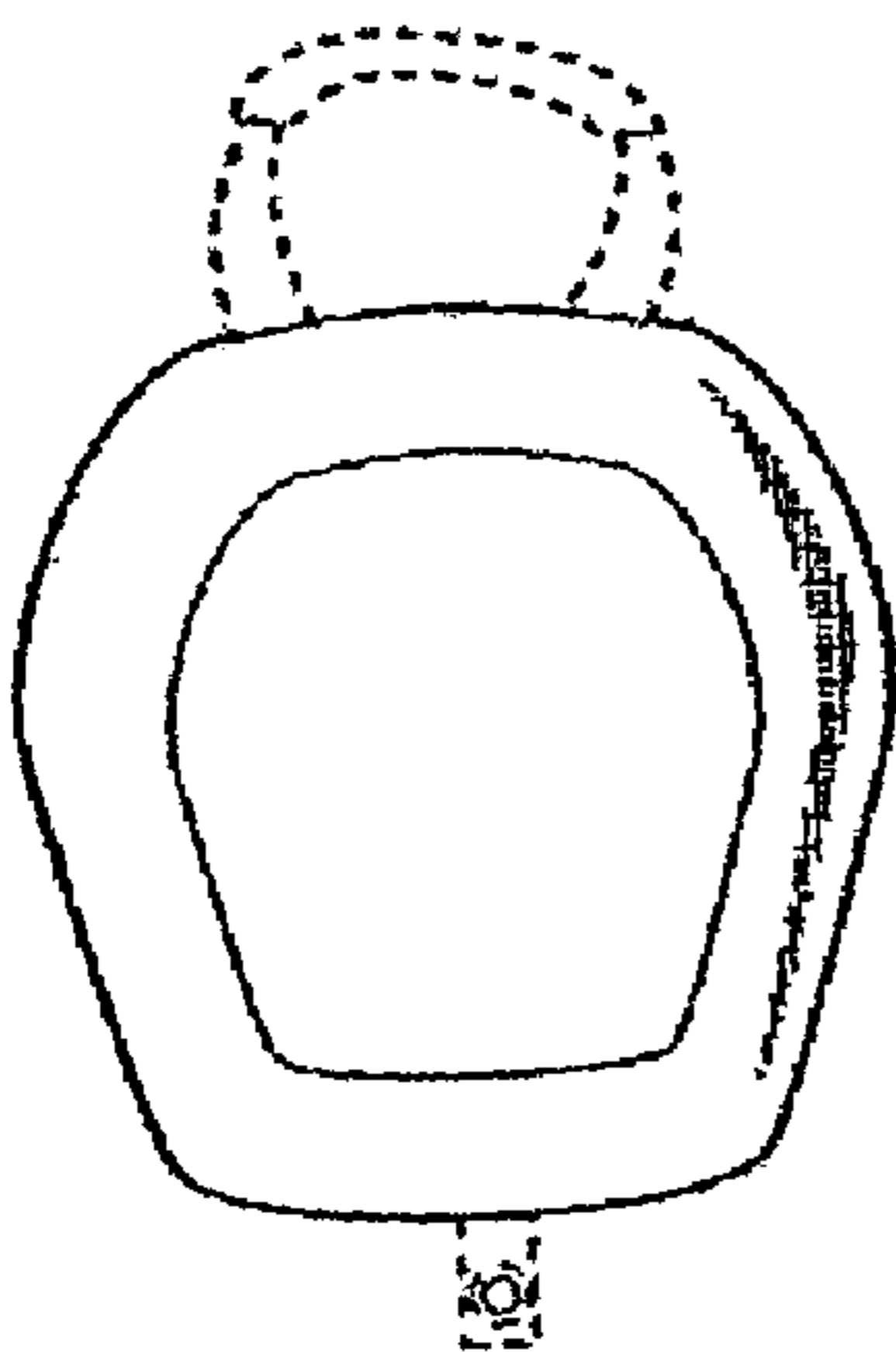

FIG. 23

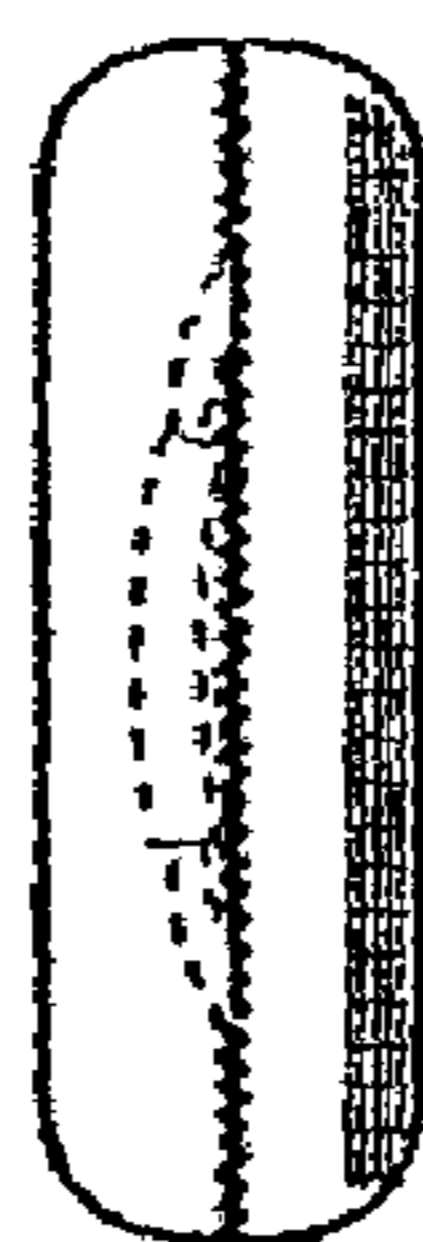

FIG. 24



FIG. 26