

US00D600218S

(12) **United States Design Patent**  
**Otsuki et al.**

(10) **Patent No.:** **US D600,218 S**  
(45) **Date of Patent:** **\*\* Sep. 15, 2009**

(54) **HEAT SINK**

2006/0126303 A1\* 6/2006 Wang et al. .... 361/704

(75) Inventors: **Takaya Otsuki**, Kyoto (JP); **Takamasa Yamashita**, Kyoto (JP); **Akira Hirakawa**, Kyoto (JP)

FOREIGN PATENT DOCUMENTS

JP	D1237688 S	4/2005
JP	D1237951 S	4/2005
JP	D1237952 S	4/2005
JP	D1237953 S	4/2005
JP	D1295760 S	3/2007
JP	D1296655 S	3/2007
TW	D118870 S	9/2007

(73) Assignee: **Nidec Corporation**, Kyoto (JP)

(\*\*) Term: **14 Years**

OTHER PUBLICATIONS

(21) Appl. No.: **29/299,170**

Otsuki et al.; "Heat Sink, Heat Sink Fan, and Method for Manufacturing the Same"; U.S. Appl. No. 11/961,050, filed Dec. 20, 2007.

(22) Filed: **Dec. 20, 2007**

(30) **Foreign Application Priority Data**

Jun. 20, 2007	(JP)	.....	2007-016489
Jul. 23, 2007	(JP)	.....	2007-019935

\* cited by examiner

*Primary Examiner*—Selina Sikder

(74) *Attorney, Agent, or Firm*—Keating & Bennett, LLP

(51) **LOC (9) Cl.** ..... **13-03**

(52) **U.S. Cl.** ..... **D13/179**

(58) **Field of Classification Search** ..... D13/179;  
165/80.3, 104.33, 151, 122, 185; 257/706,  
257/707, 718-722; 361/687, 695, 697, 700,  
361/702, 704, 709, 710, 711, 719

(57) **CLAIM**

See application file for complete search history.

The ornamental design for a heat sink, as shown and described.

**DESCRIPTION**

(56) **References Cited**

U.S. PATENT DOCUMENTS

6,552,902 B2 *	4/2003	Cho et al. ....	361/704
D476,958 S *	7/2003	Tsai .....	D13/179
6,714,415 B1 *	3/2004	Shah .....	361/704
6,779,593 B1	8/2004	Hegde	
7,123,483 B2 *	10/2006	Otsuki et al. ....	361/710
7,142,426 B2 *	11/2006	Wang et al. ....	361/704
7,269,013 B2 *	9/2007	Chen et al. ....	361/700
D561,123 S *	2/2008	Mochizuki et al. ....	D13/179
D568,829 S *	5/2008	Yamashita et al. ....	D13/179
2002/0017378 A1 *	2/2002	Hu .....	165/80.3
2002/0046826 A1 *	4/2002	Kao .....	165/104.33
2003/0131970 A1 *	7/2003	Carter et al. ....	165/80.3
2004/0045702 A1 *	3/2004	Barsun .....	165/185
2005/0056399 A1 *	3/2005	Ku et al. ....	165/80.3
2005/0061480 A1 *	3/2005	Carter et al. ....	165/80.3

FIG. 1 is a front elevation view of a first embodiment of a heat sink according to our new design;

FIG. 2 is a rear elevation view thereof;

FIG. 3 is a right side elevation view thereof;

FIG. 4 is a left side elevation view thereof;

FIG. 5 is a top plan view thereof;

FIG. 6 is a bottom plan view thereof;

FIG. 7 is a perspective view thereof;

FIG. 8 is another perspective view thereof;

FIG. 9 is another front elevation view thereof;

FIG. 10 is a sectional view along A—A' in FIG. 9;

FIG. 11 is a front elevation view of a second embodiment of a heat sink according to a modification of our new design;

FIG. 12 is a rear elevation view thereof;

FIG. 13 is a right side elevation view thereof;

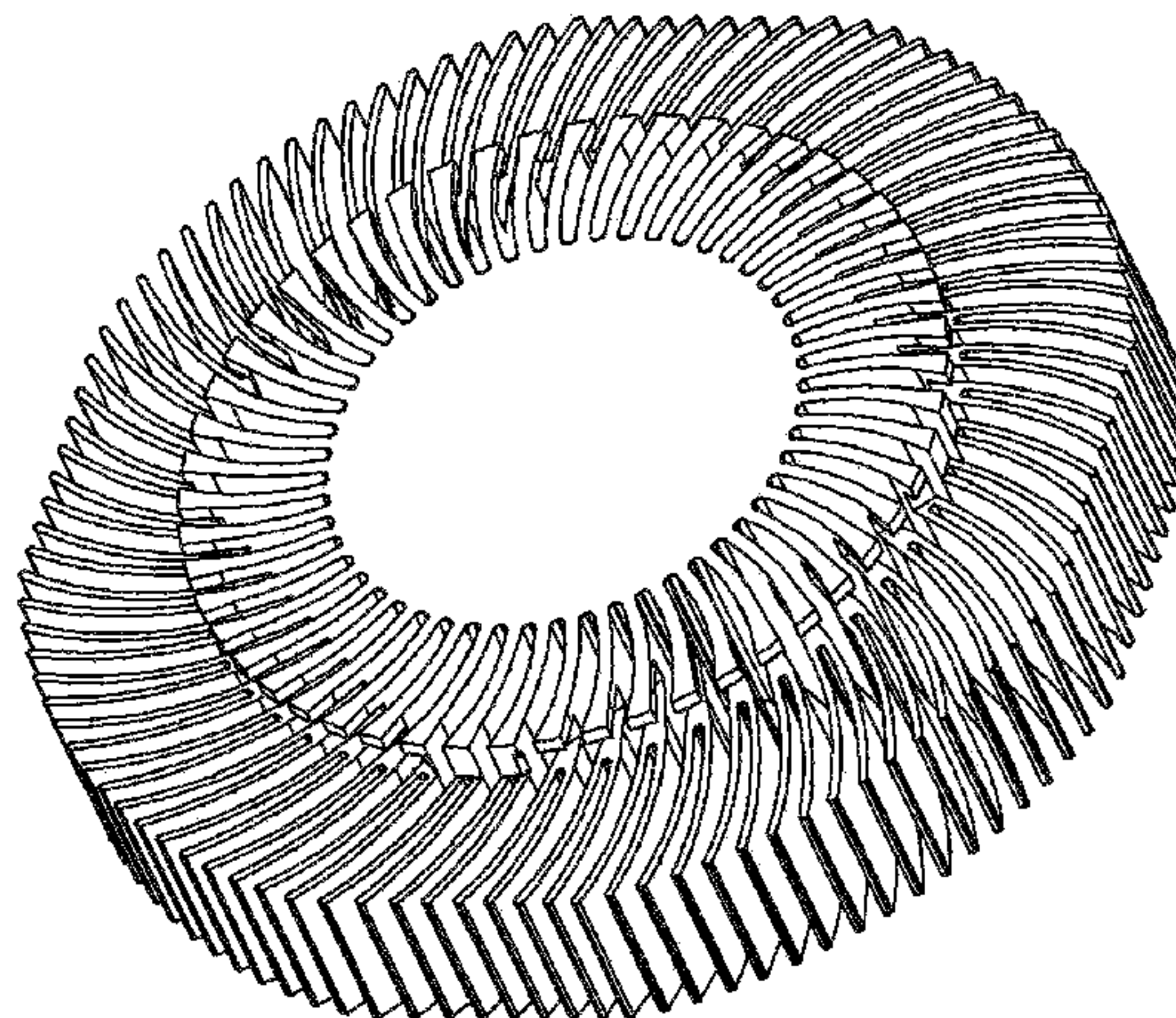
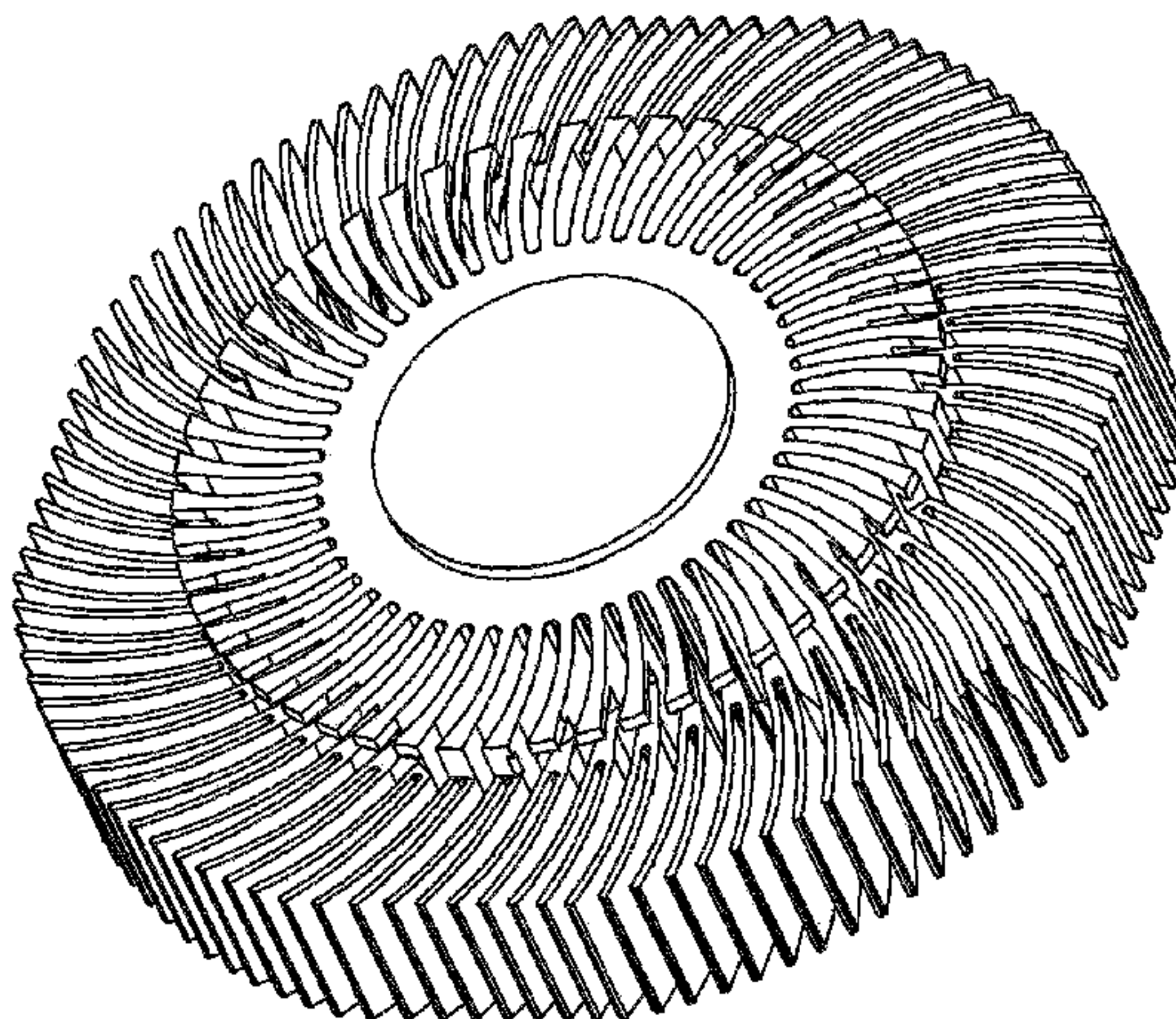

FIG. **14** is a left side elevation view thereof;

FIG. **15** is a top plan view thereof;

FIG. **16** is a bottom plan view thereof;

FIG. **17** is a perspective view thereof;

FIG. **18** is another perspective view thereof;

FIG. **19** is another front elevation view thereof;

FIG. **20** is a sectional view along A—A' in FIG. **19**;

FIG. **21** is a front elevation view of a third embodiment of a heat sink according to another modification of our new design;

FIG. **22** is a rear elevation view thereof;

FIG. **23** is a right side elevation view thereof;

FIG. **24** is a left side elevation view thereof;

FIG. **25** is a top plan view thereof;

FIG. **26** is a bottom plan view thereof;

FIG. **27** is a perspective view thereof;

FIG. **28** is another perspective view thereof;

FIG. **29** is a front elevation view of a fourth embodiment of a heat sink according to another modification of our new design;

FIG. **30** is a rear elevation view thereof;

FIG. **31** is a right side elevation view thereof;

FIG. **32** is a left side elevation view thereof;

FIG. **33** is a top plan view thereof;

FIG. **34** is a bottom plan view thereof;

FIG. **35** is a perspective view thereof; and,

FIG. **36** is another perspective view thereof.

**1 Claim, 36 Drawing Sheets**

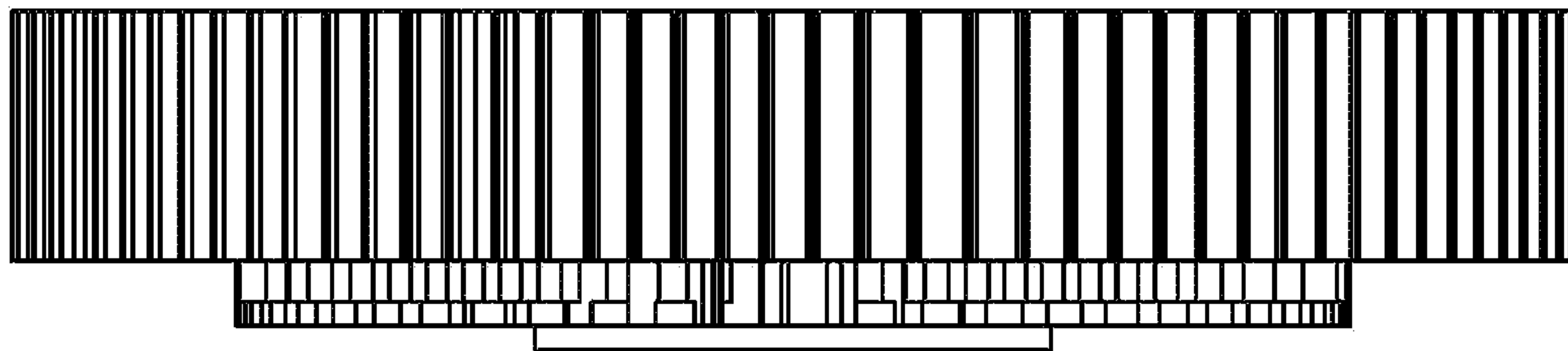

FIG. 1

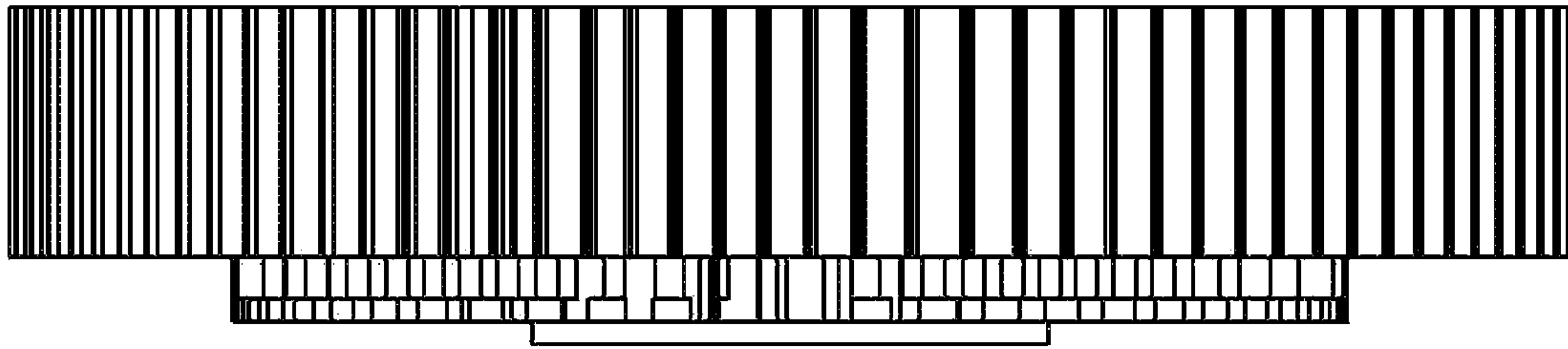

FIG. 2

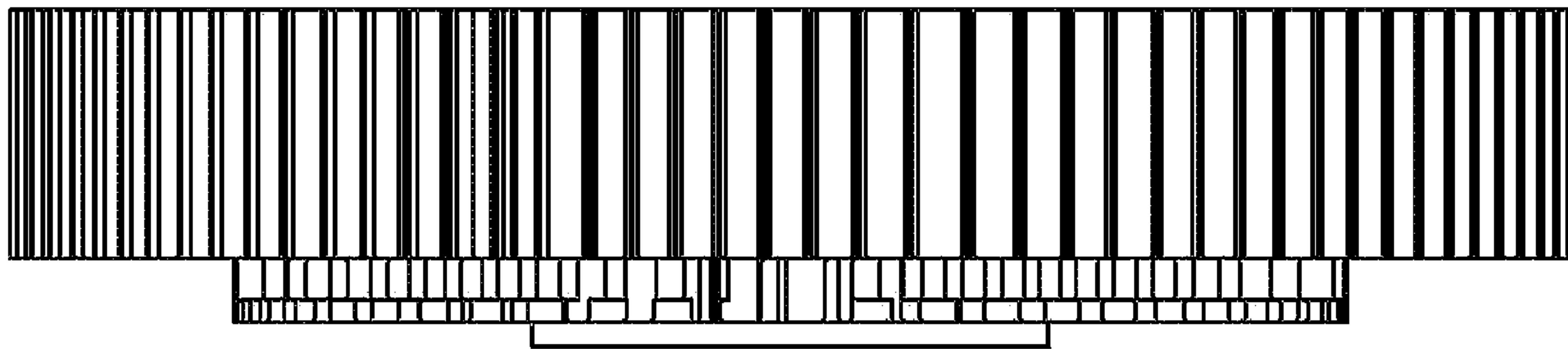

FIG. 3



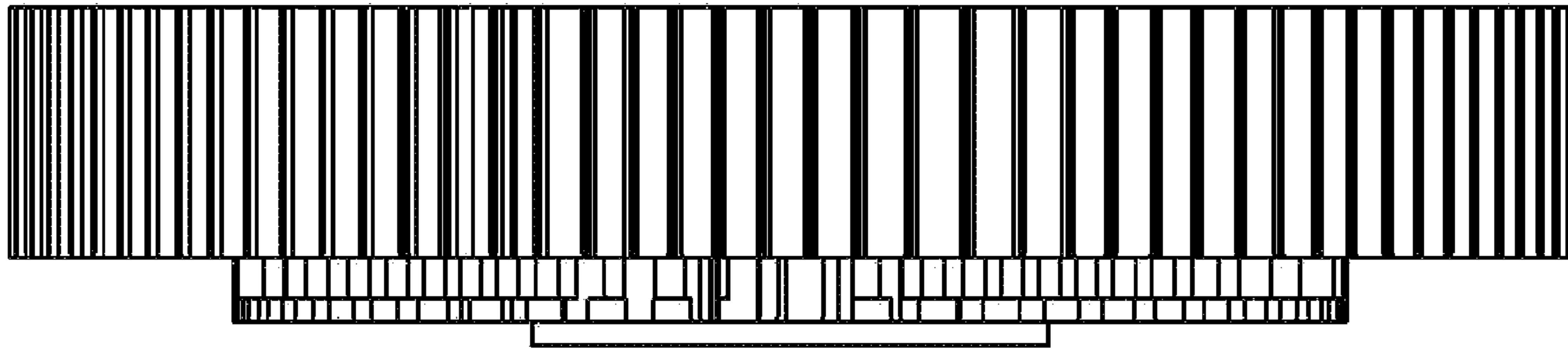

FIG. 4

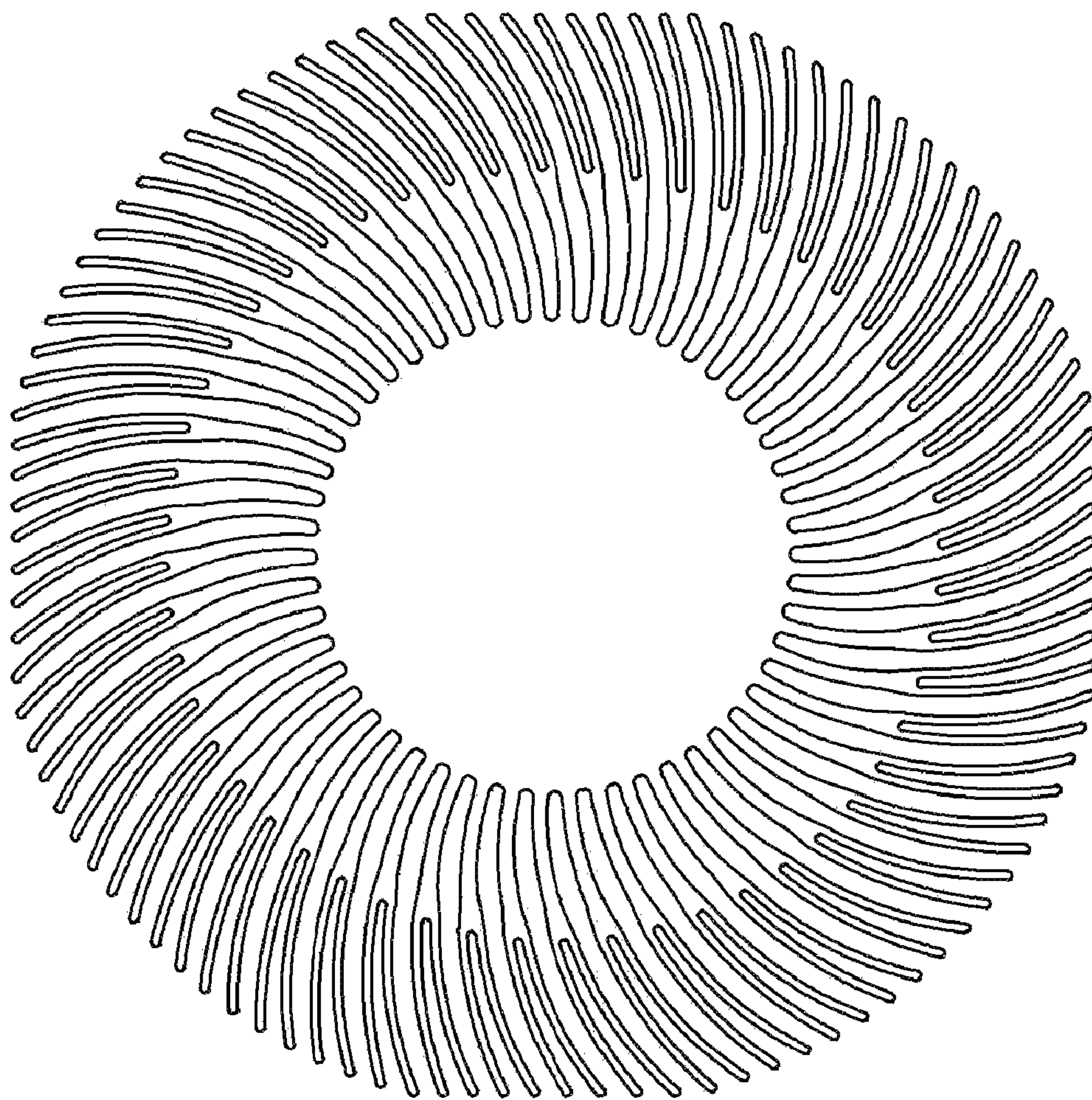

FIG. 5

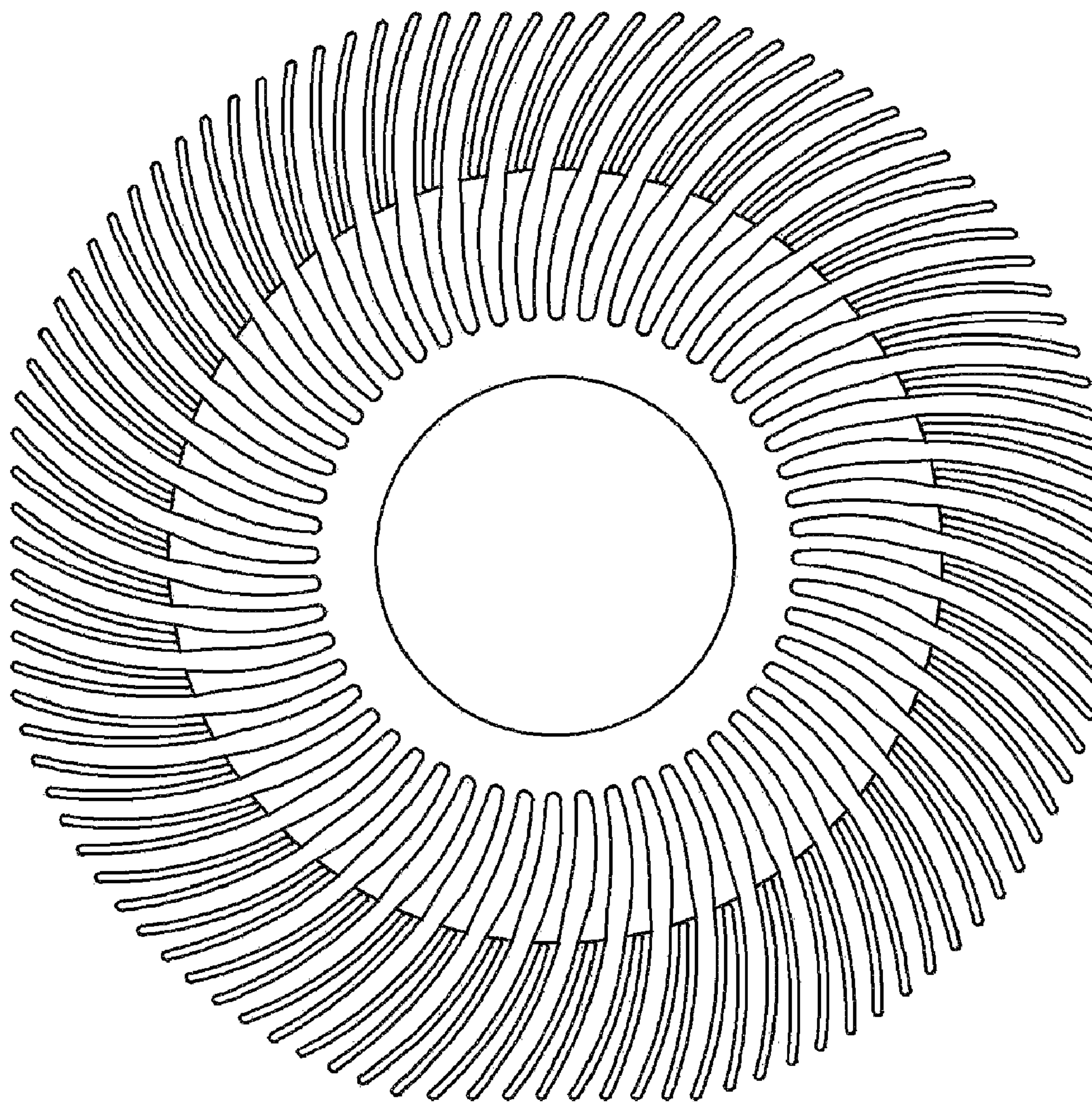

FIG. 6



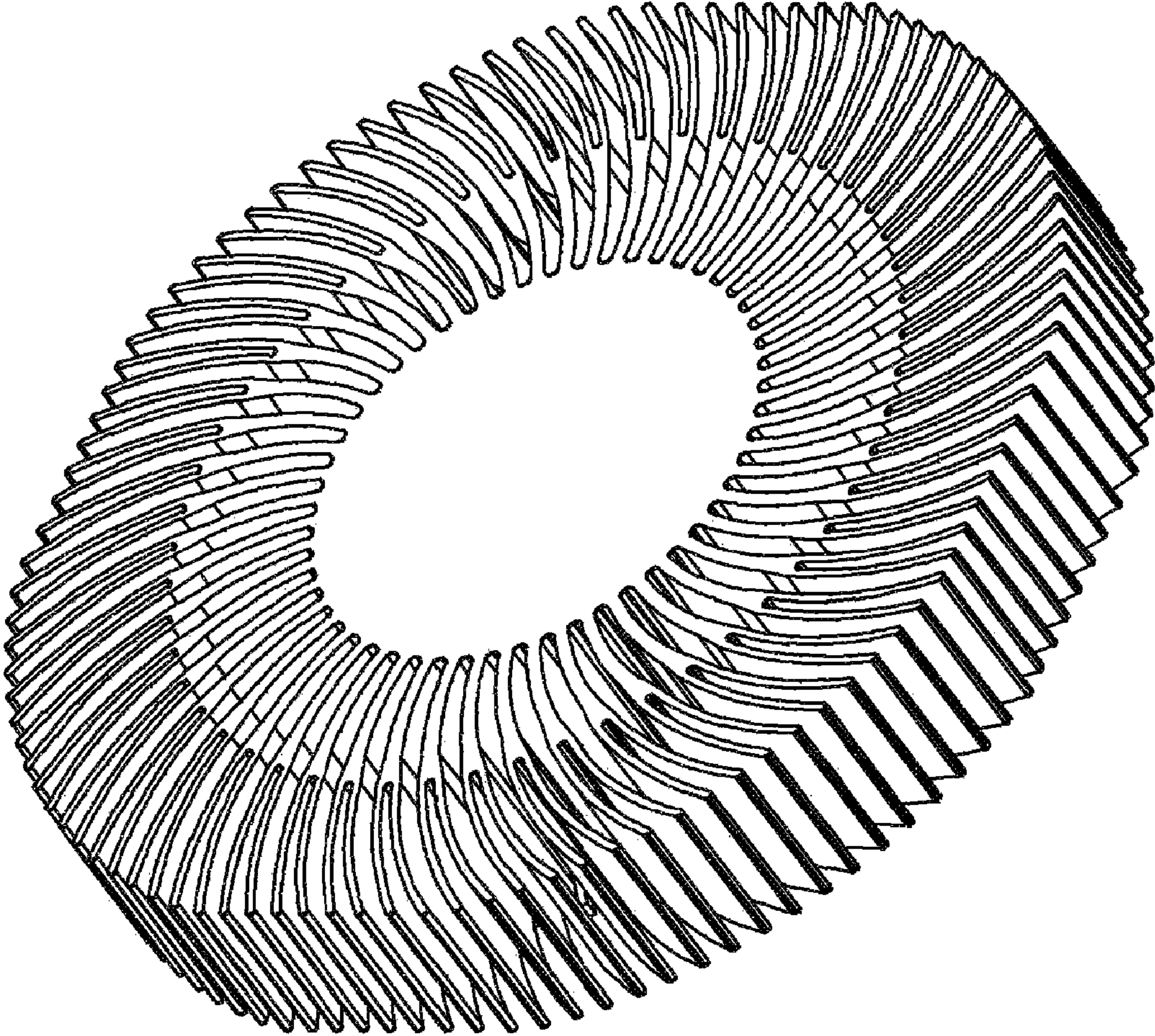

FIG. 7

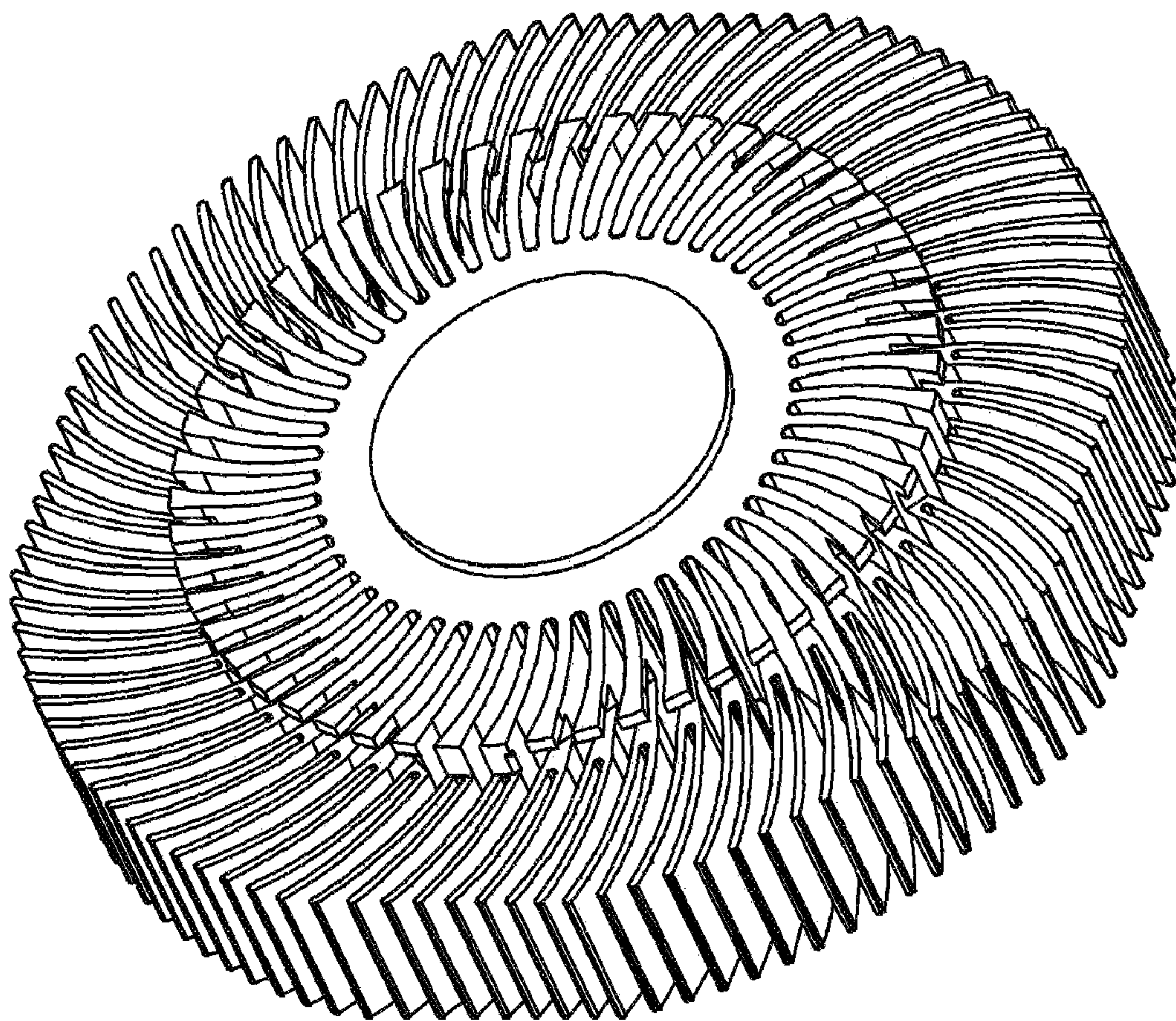

FIG. 8

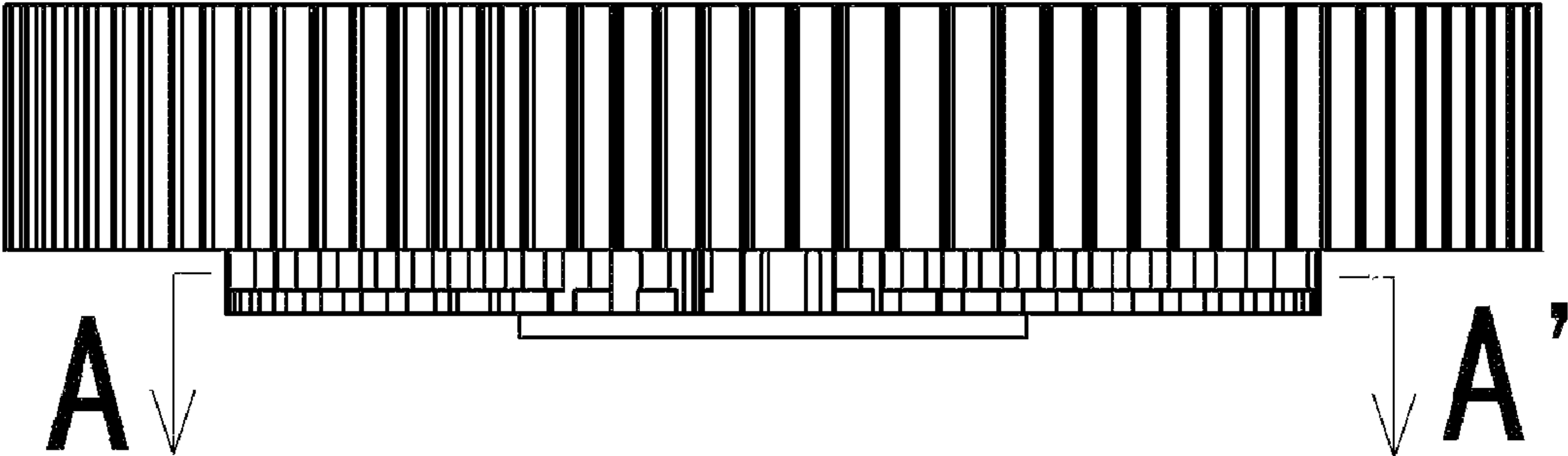

FIG. 9



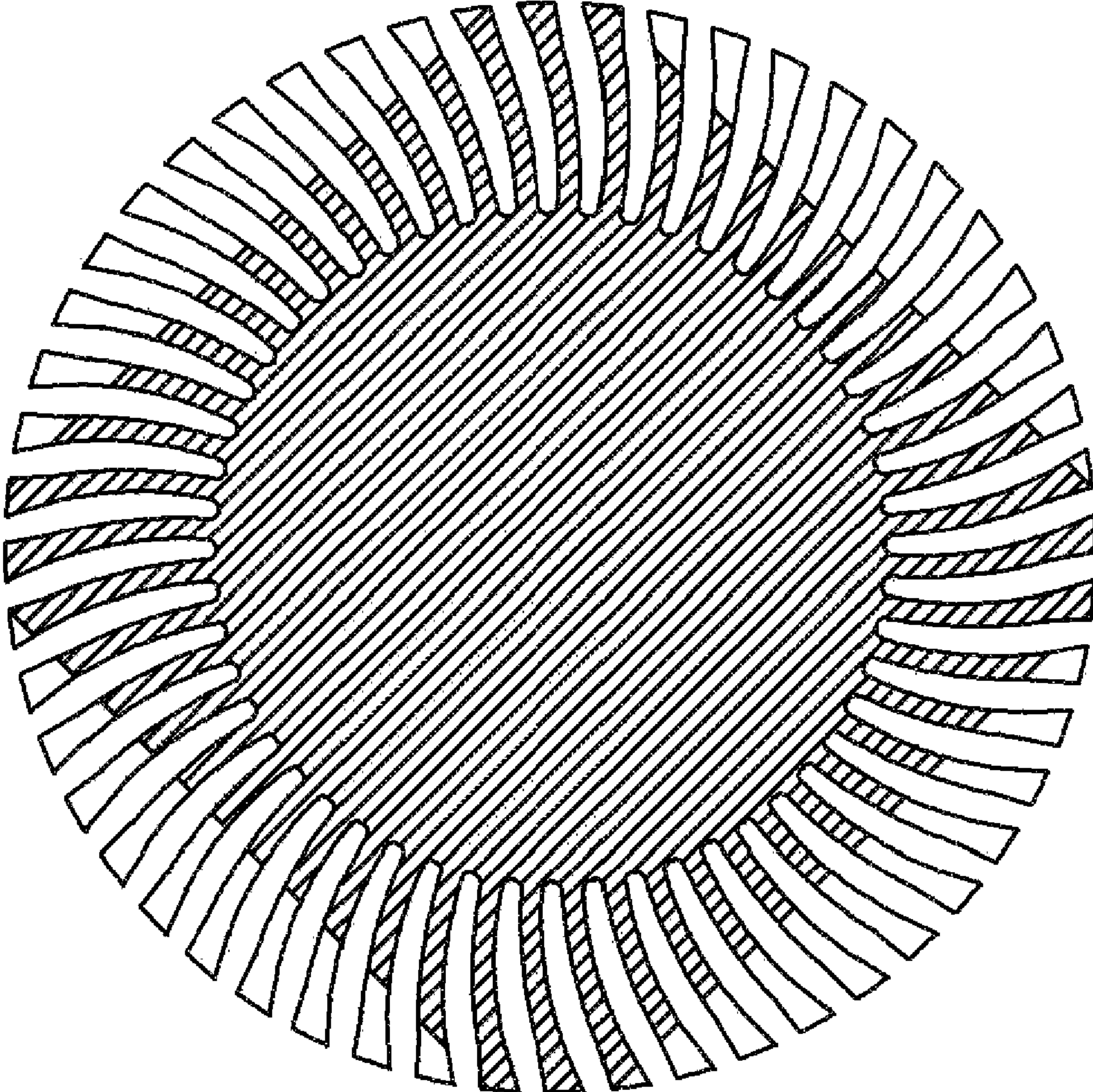

FIG. 10



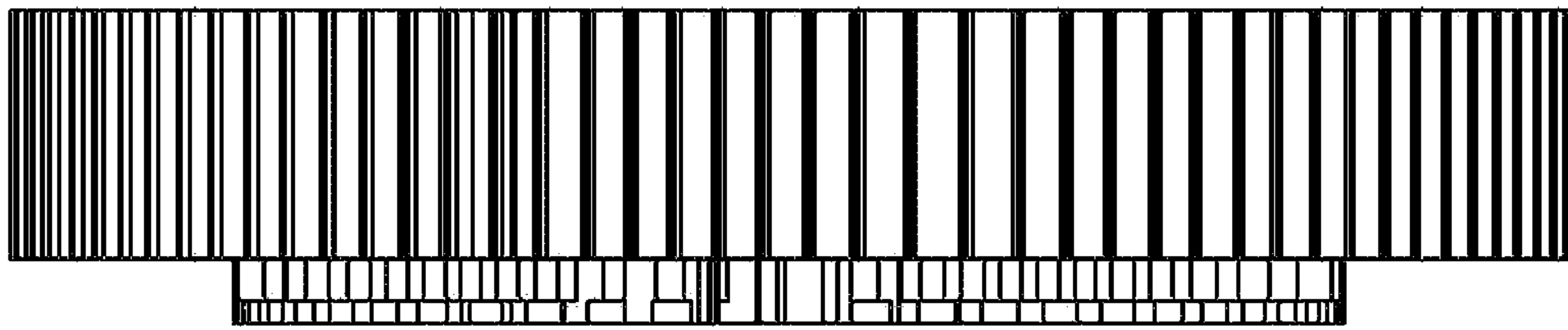

FIG. 11

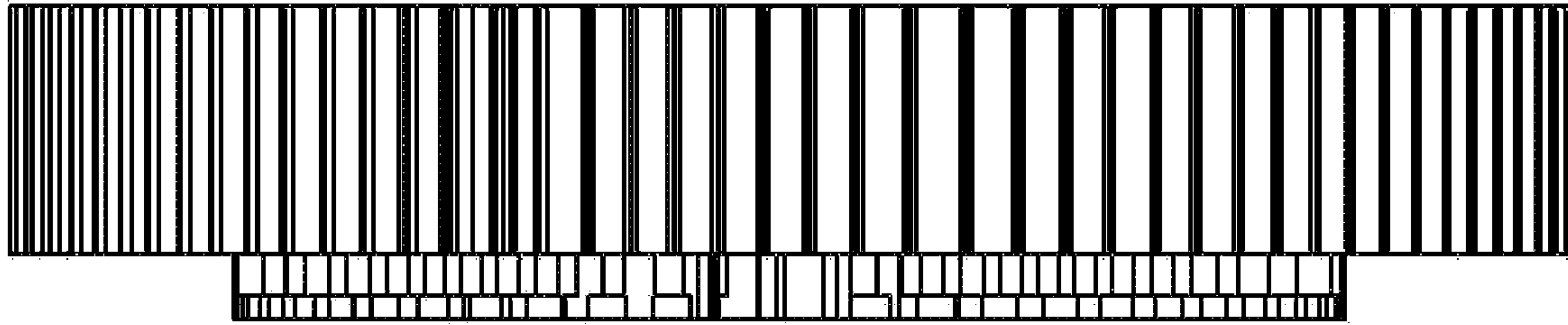

FIG. 12

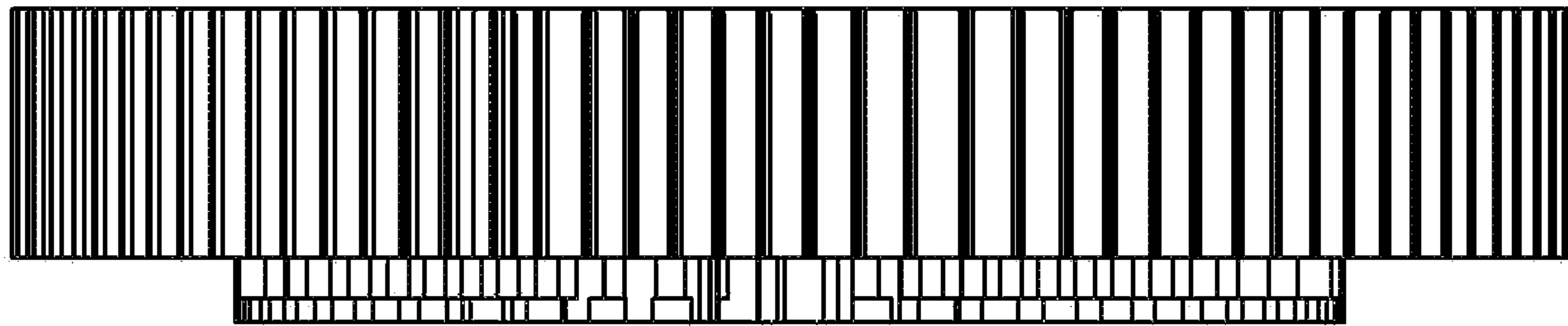

FIG. 13

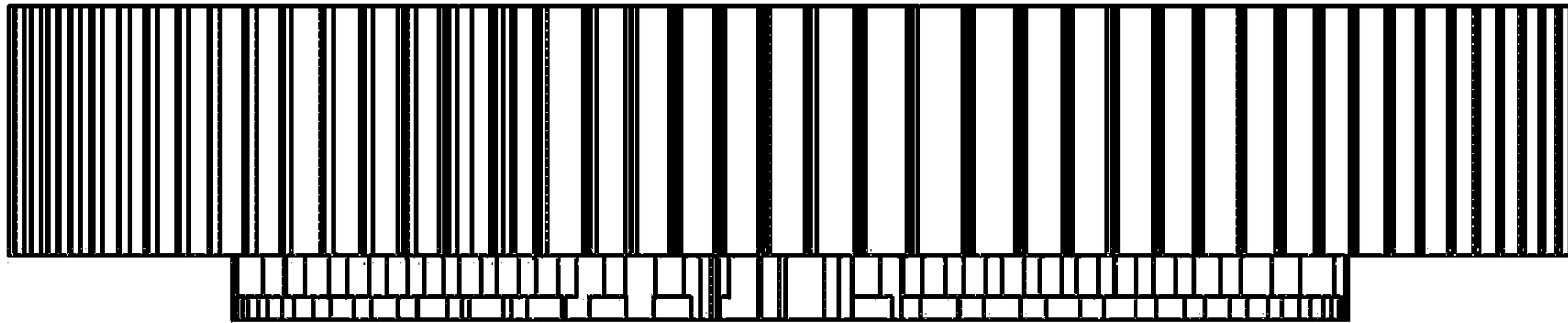

FIG. 14



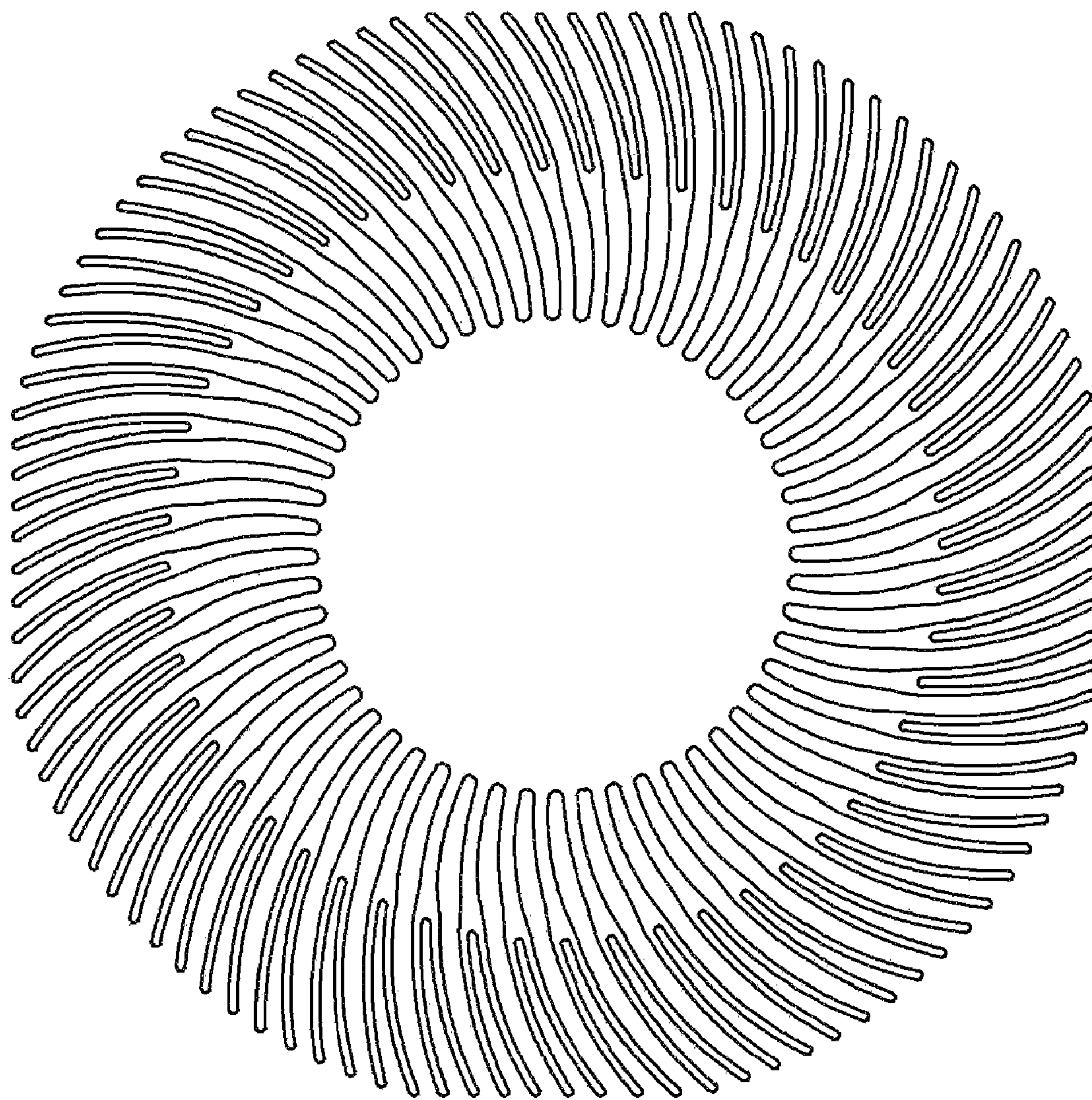

FIG. 15

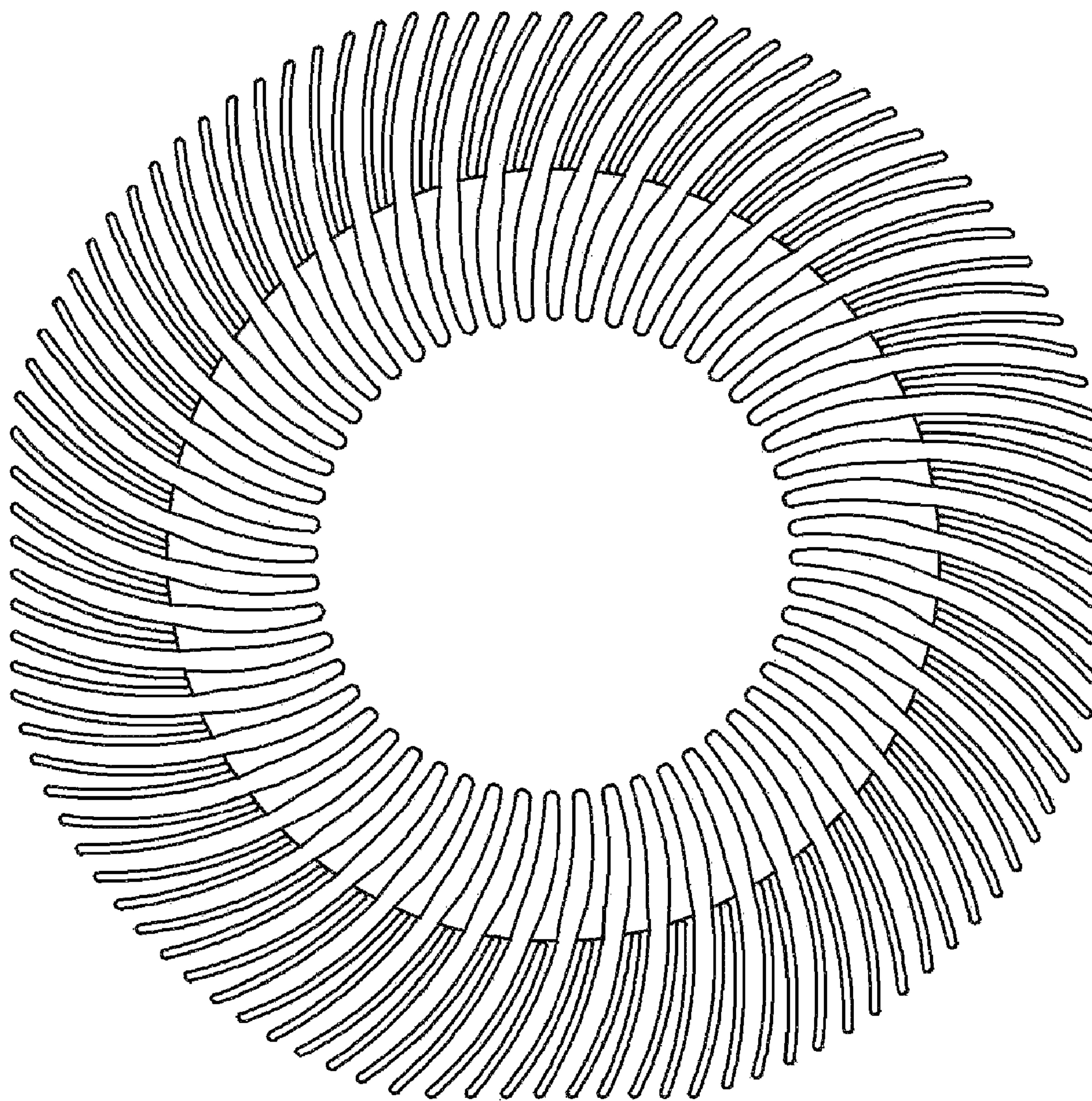

FIG. 16



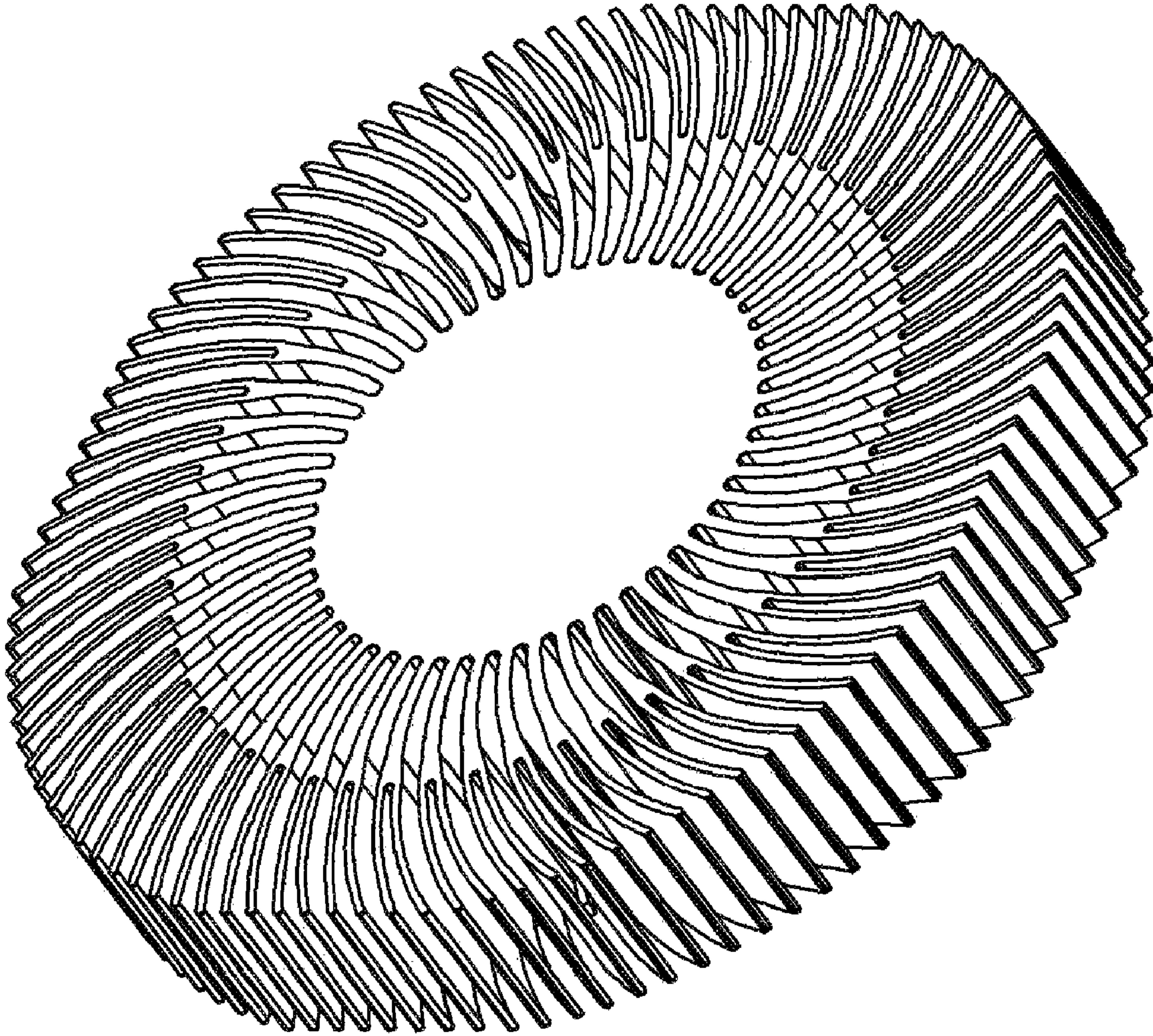

FIG. 17

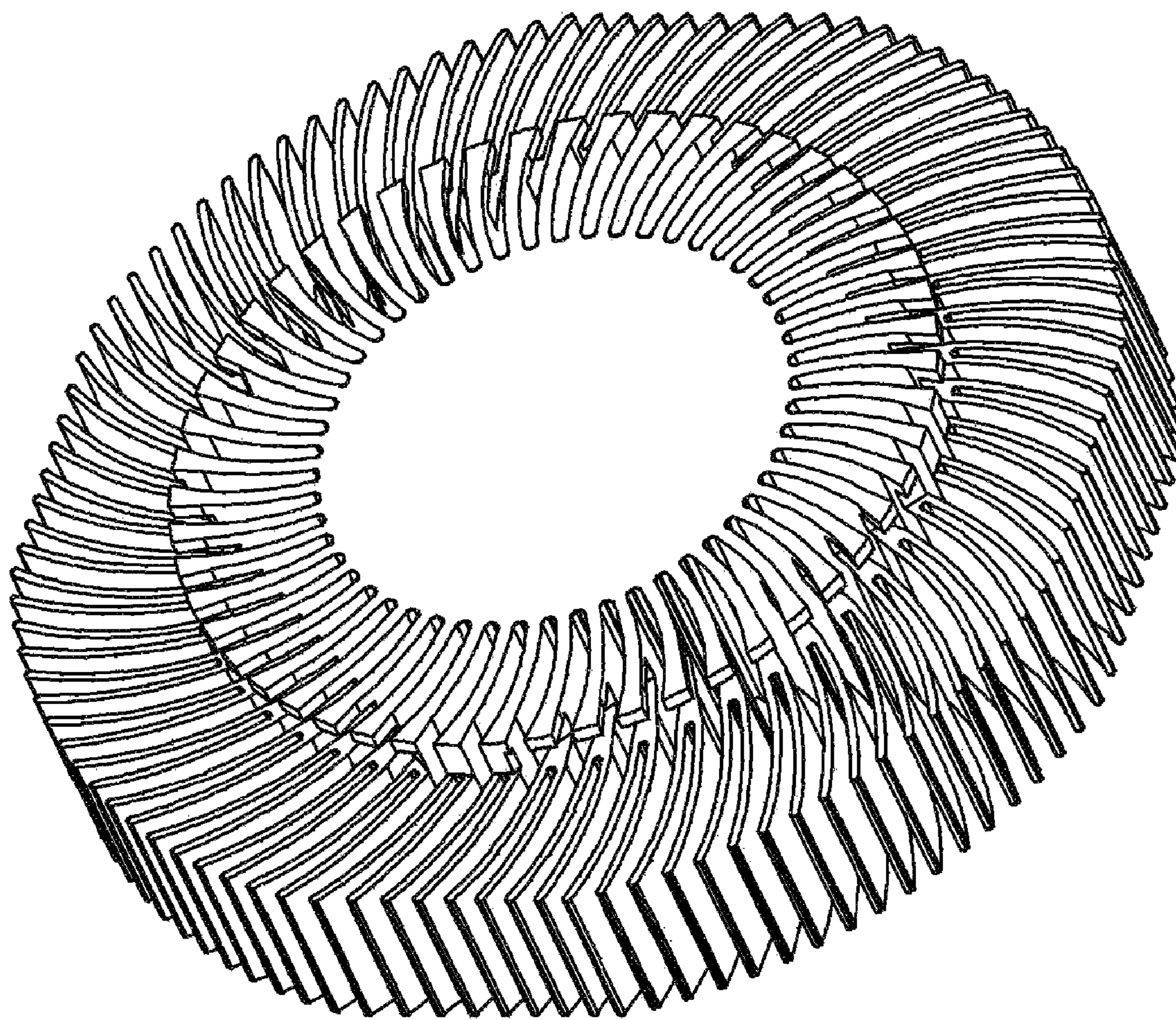

FIG. 18



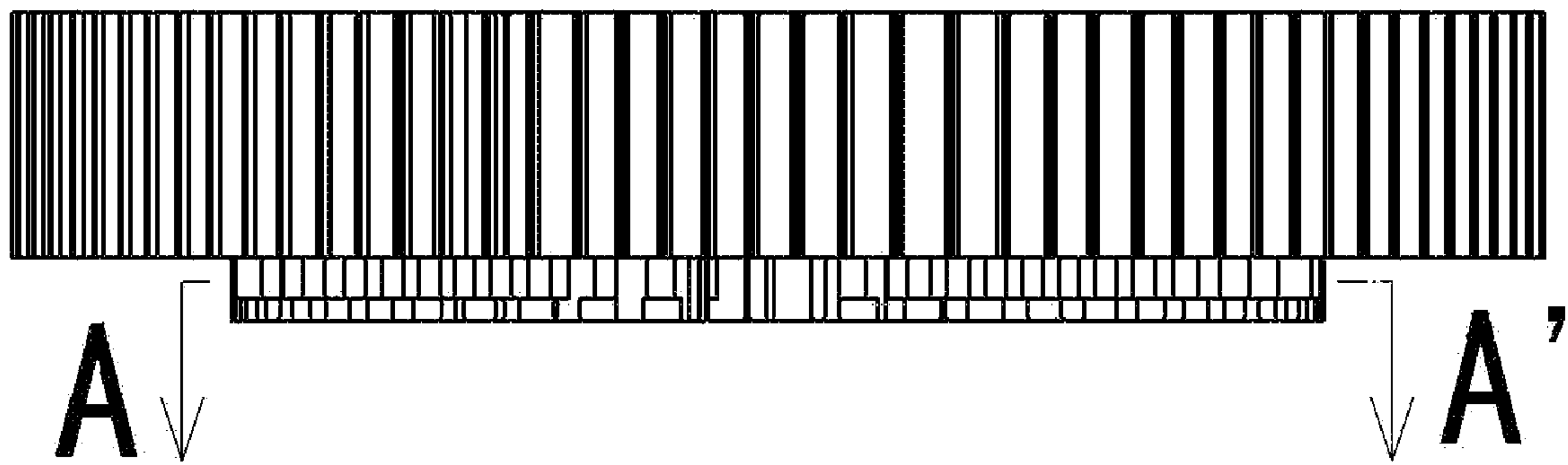

FIG. 19

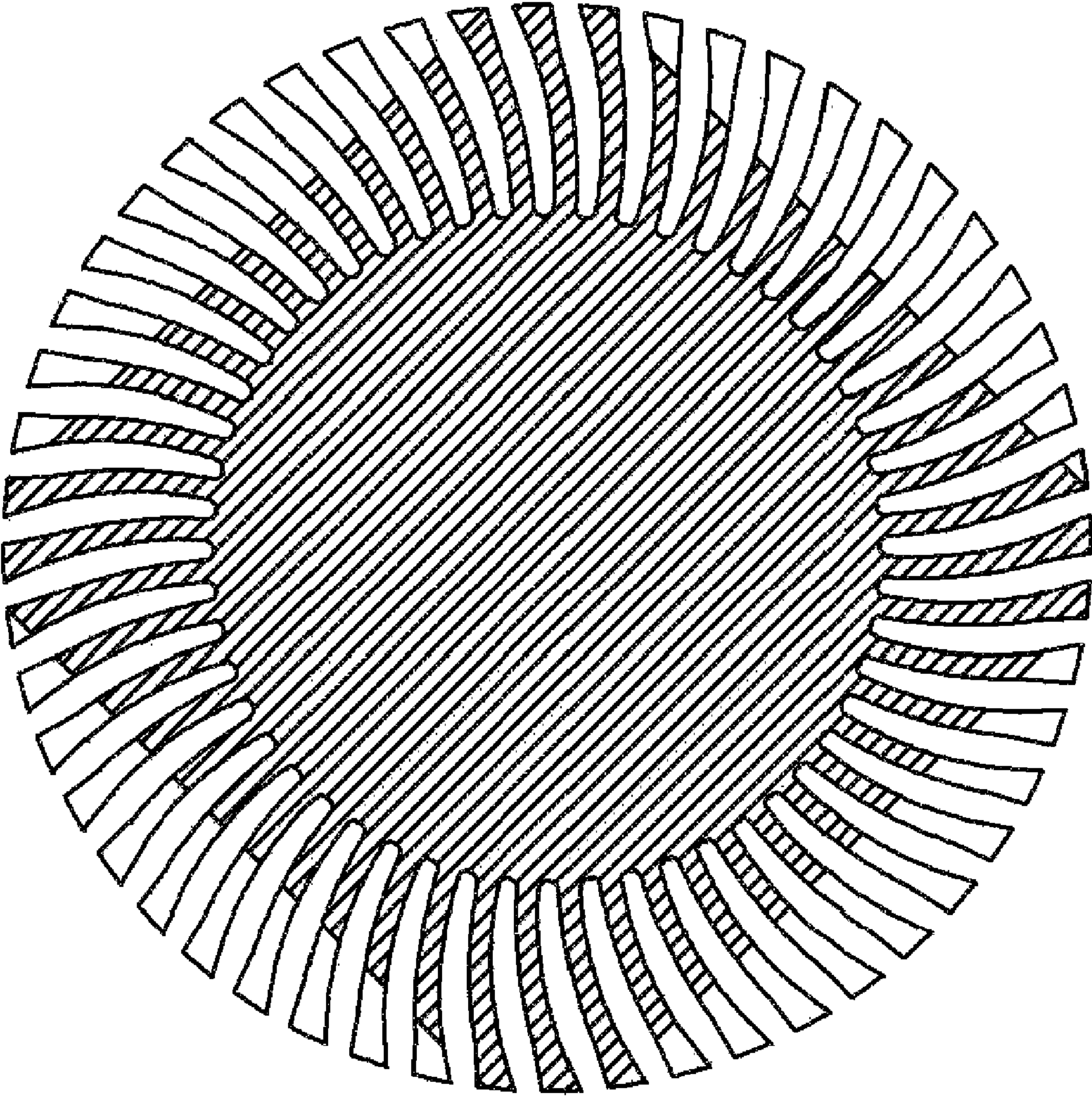

FIG. 20

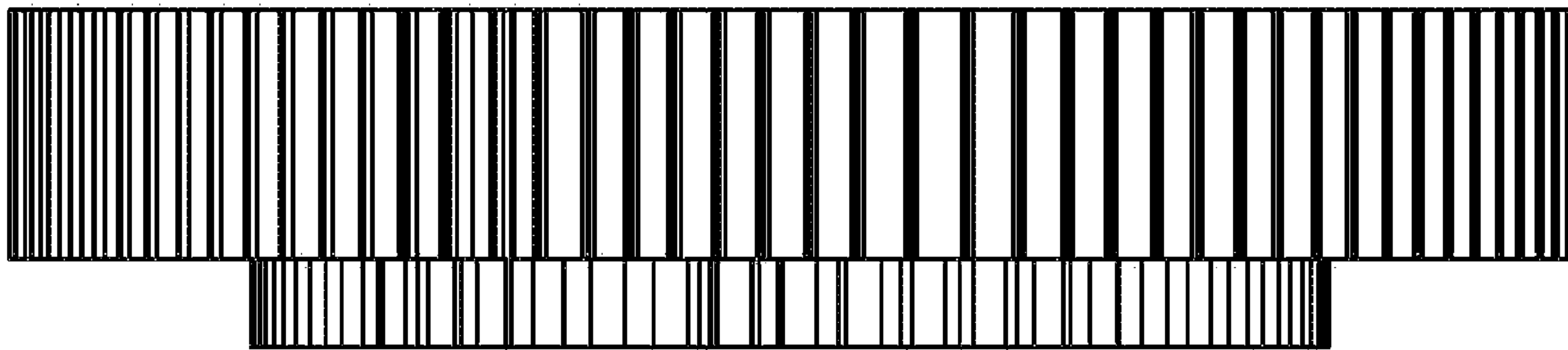

FIG. 21

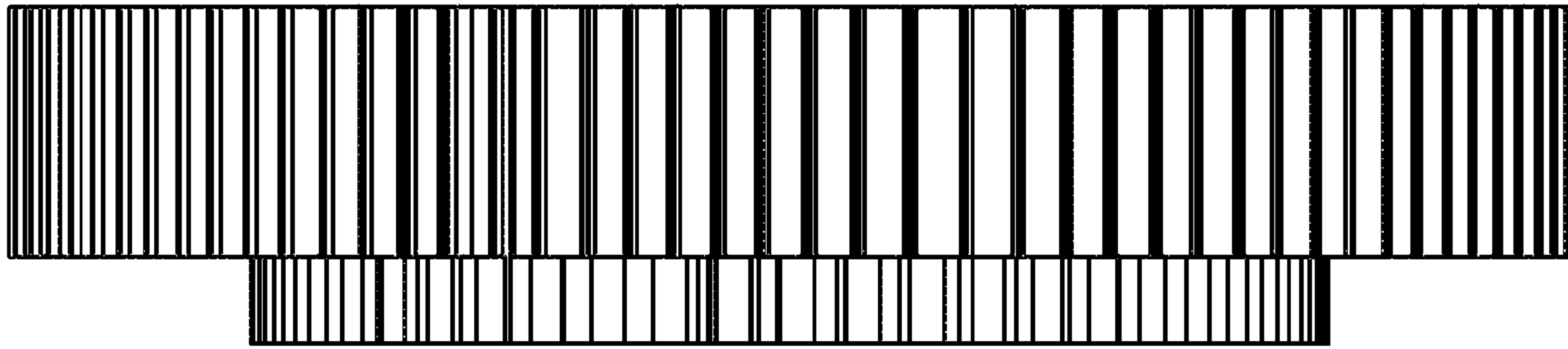

FIG. 22



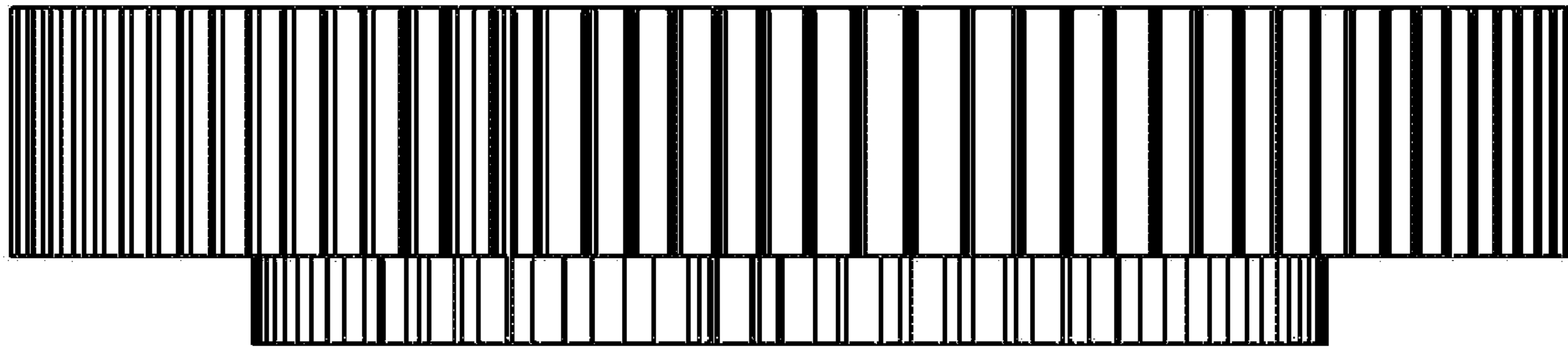

FIG. 23

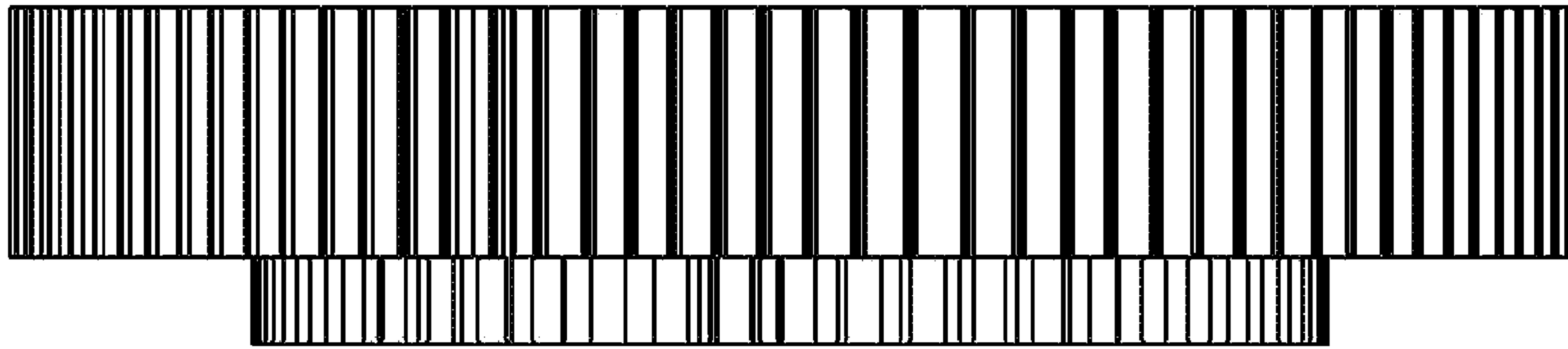

FIG. 24

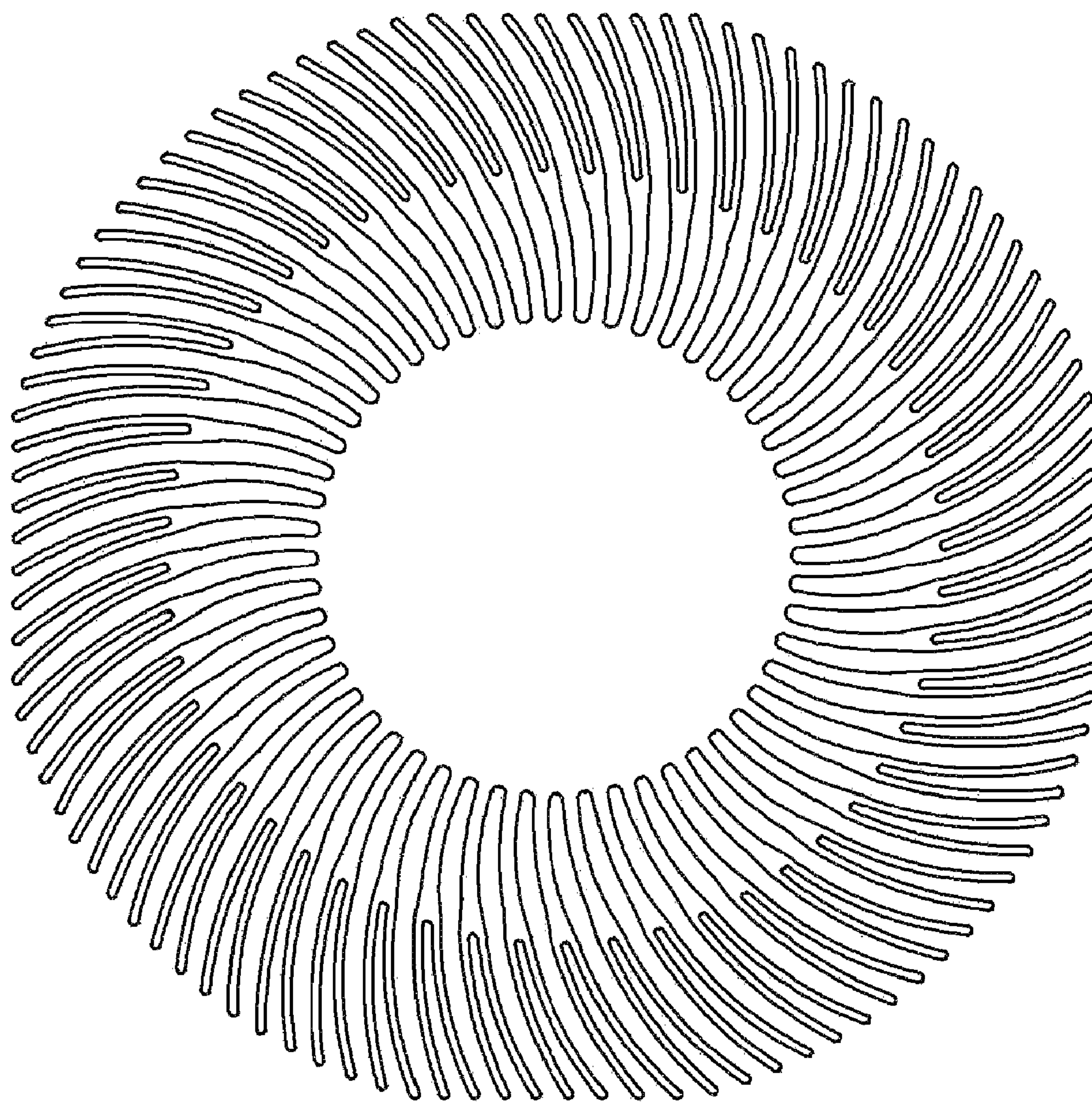

FIG. 25

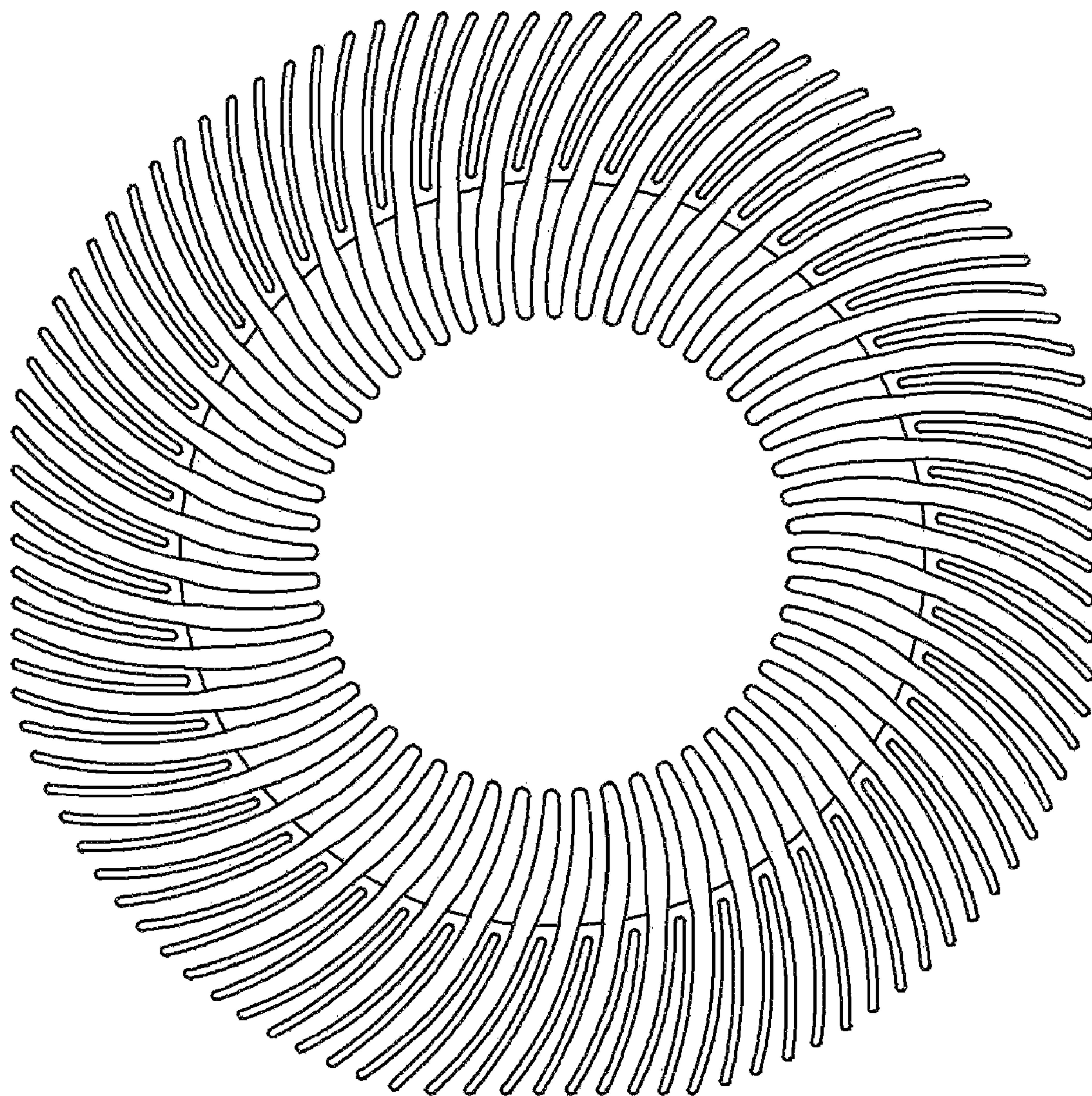

FIG. 26



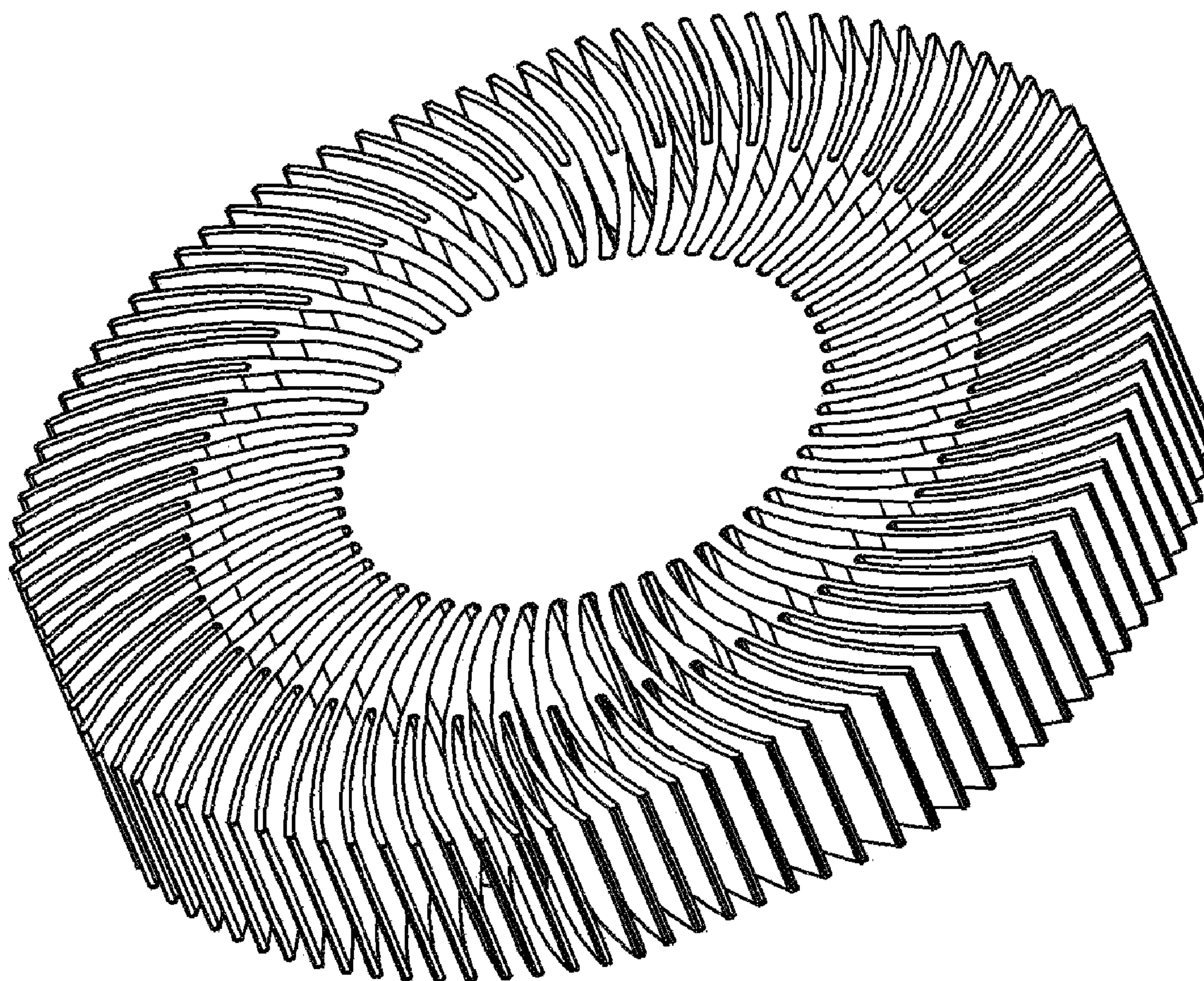

FIG. 27

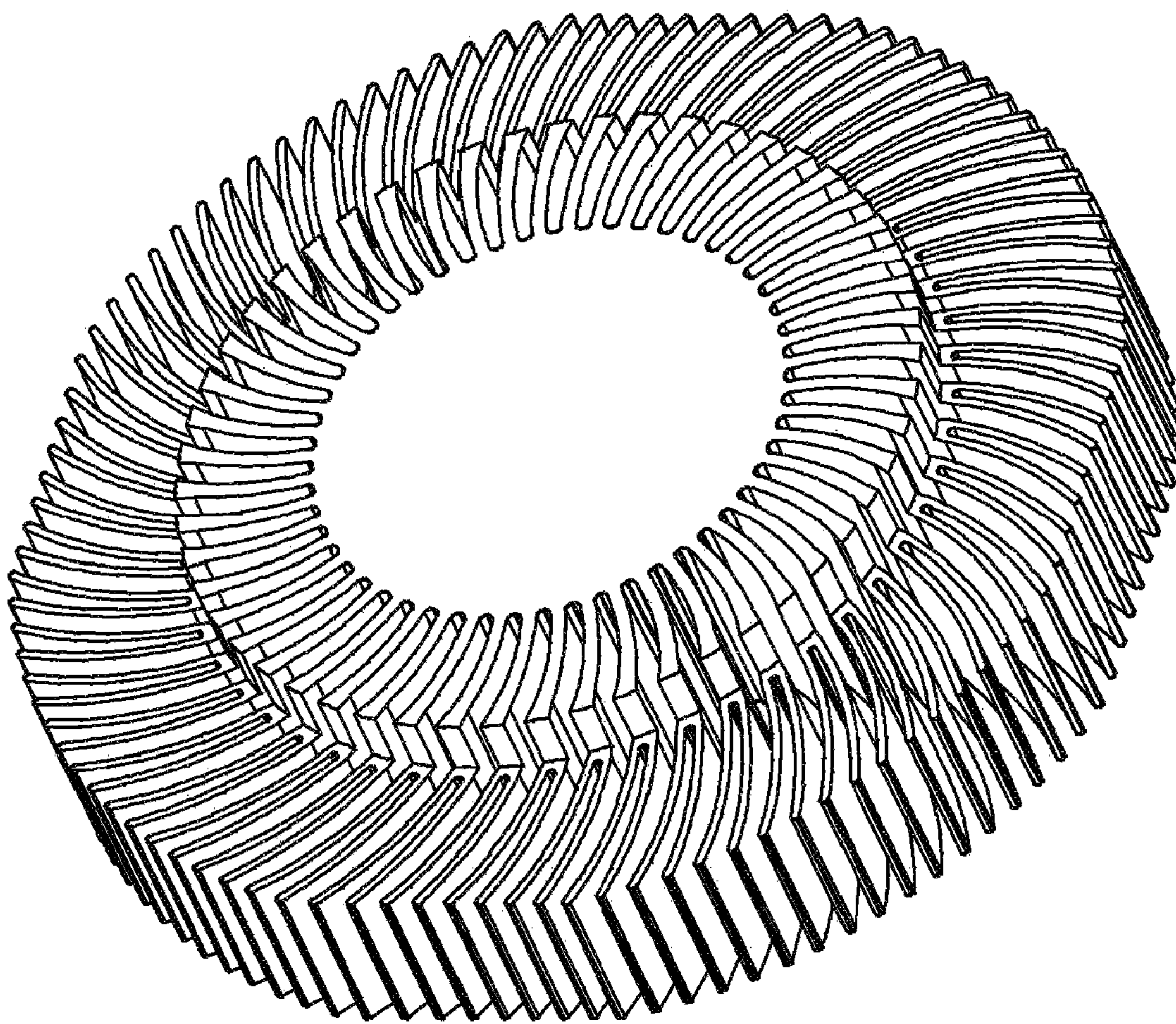

FIG. 28



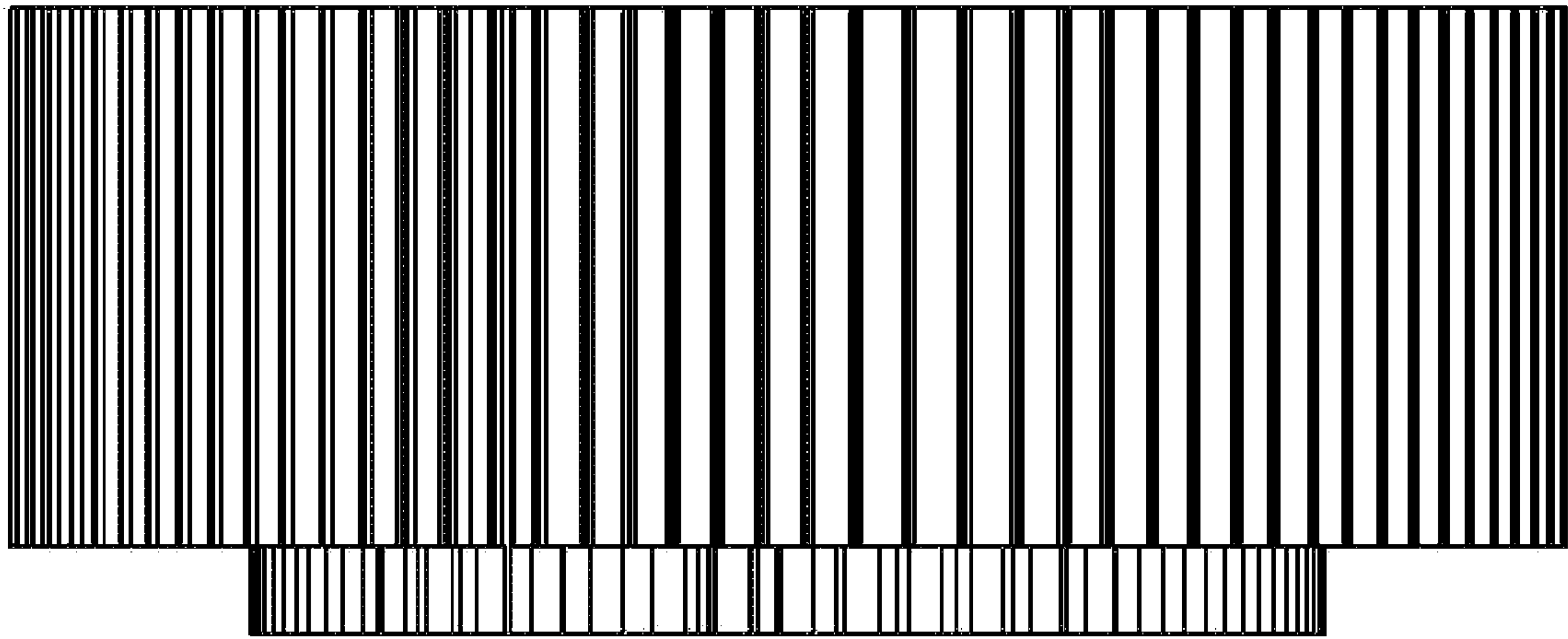

FIG. 29

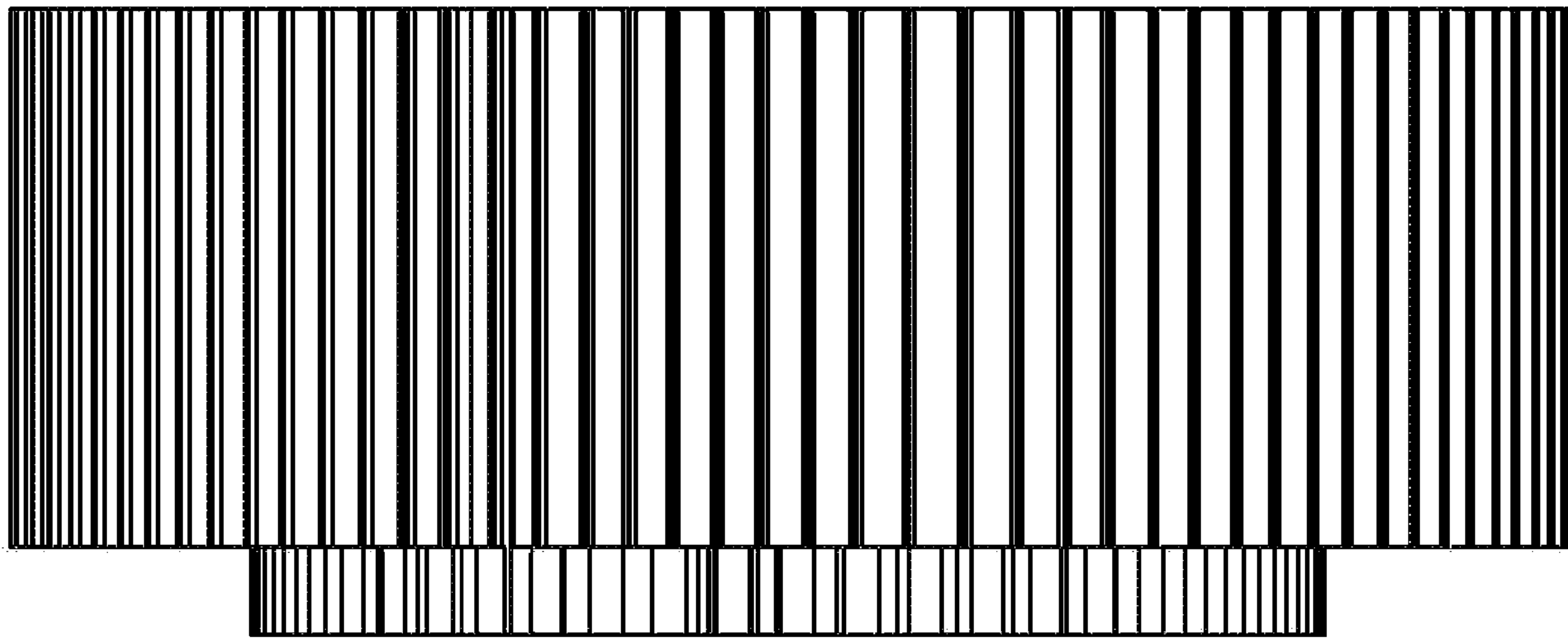

FIG. 30

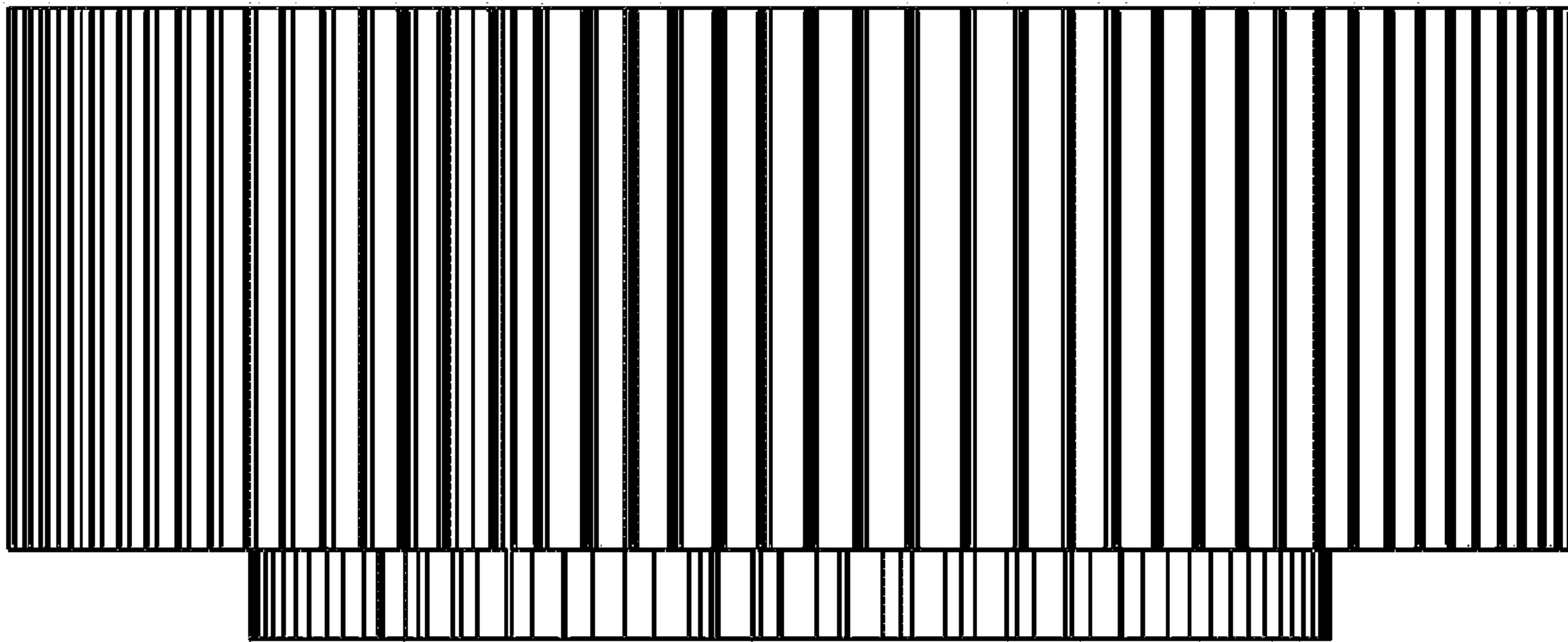

FIG. 31

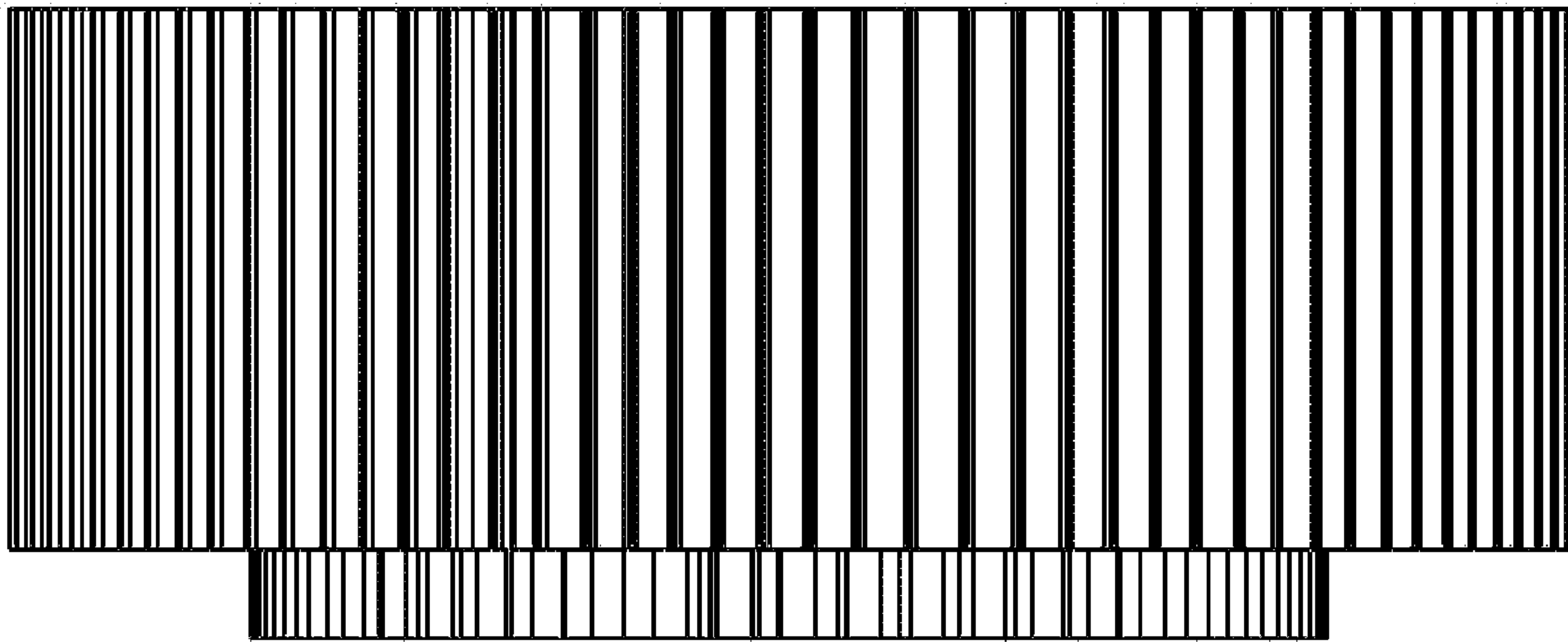

FIG. 32

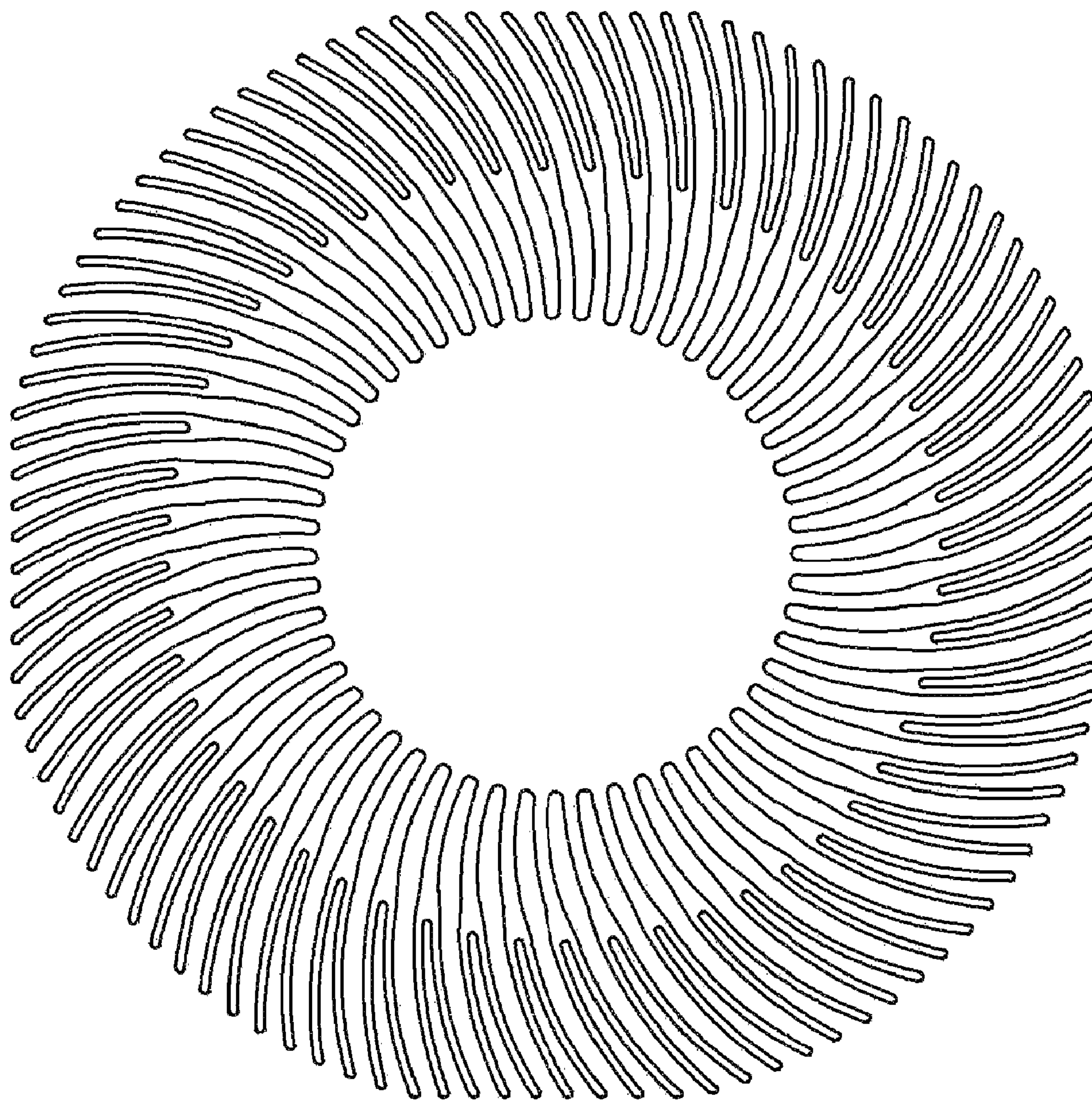

FIG. 33



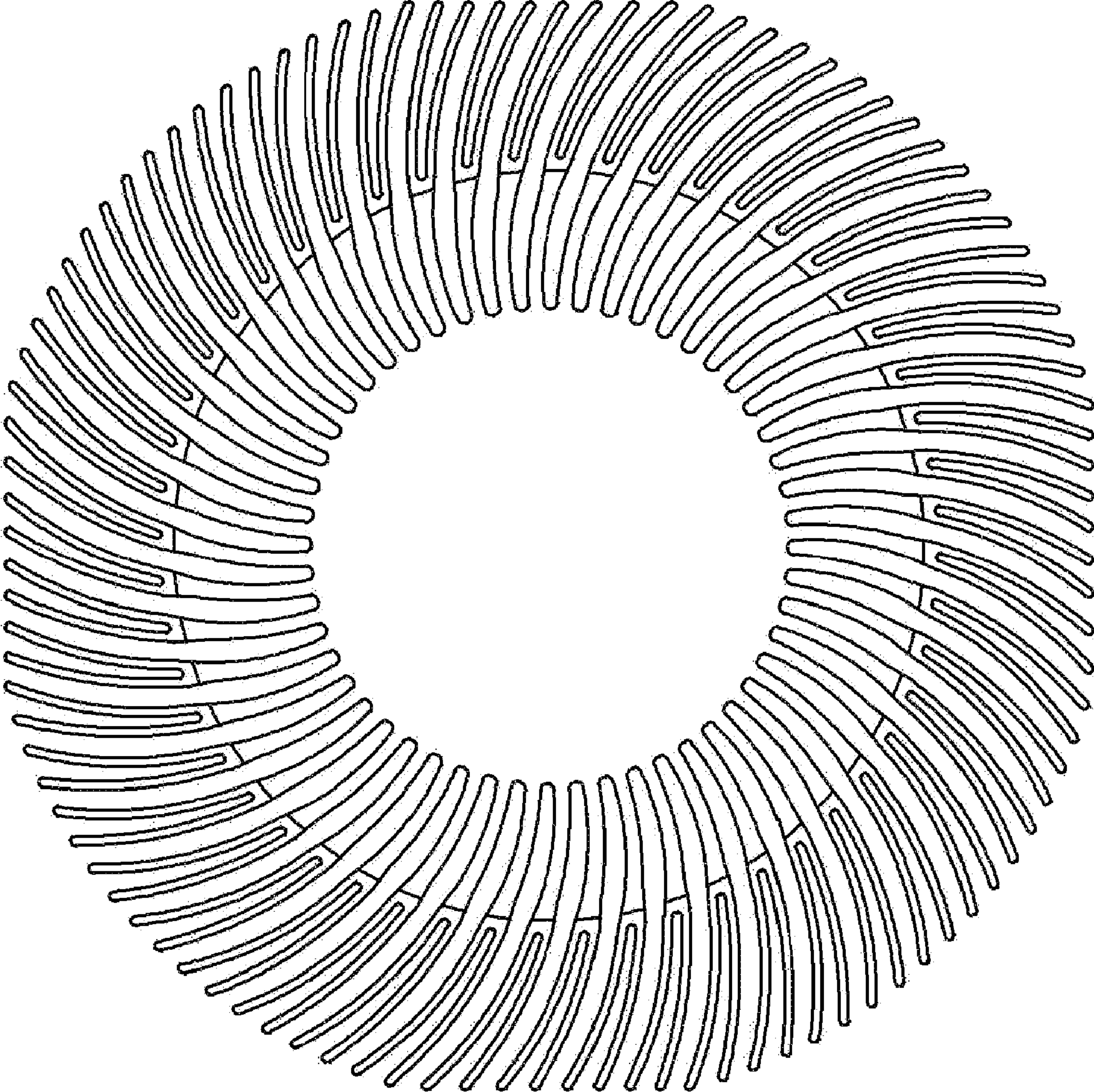

FIG. 34



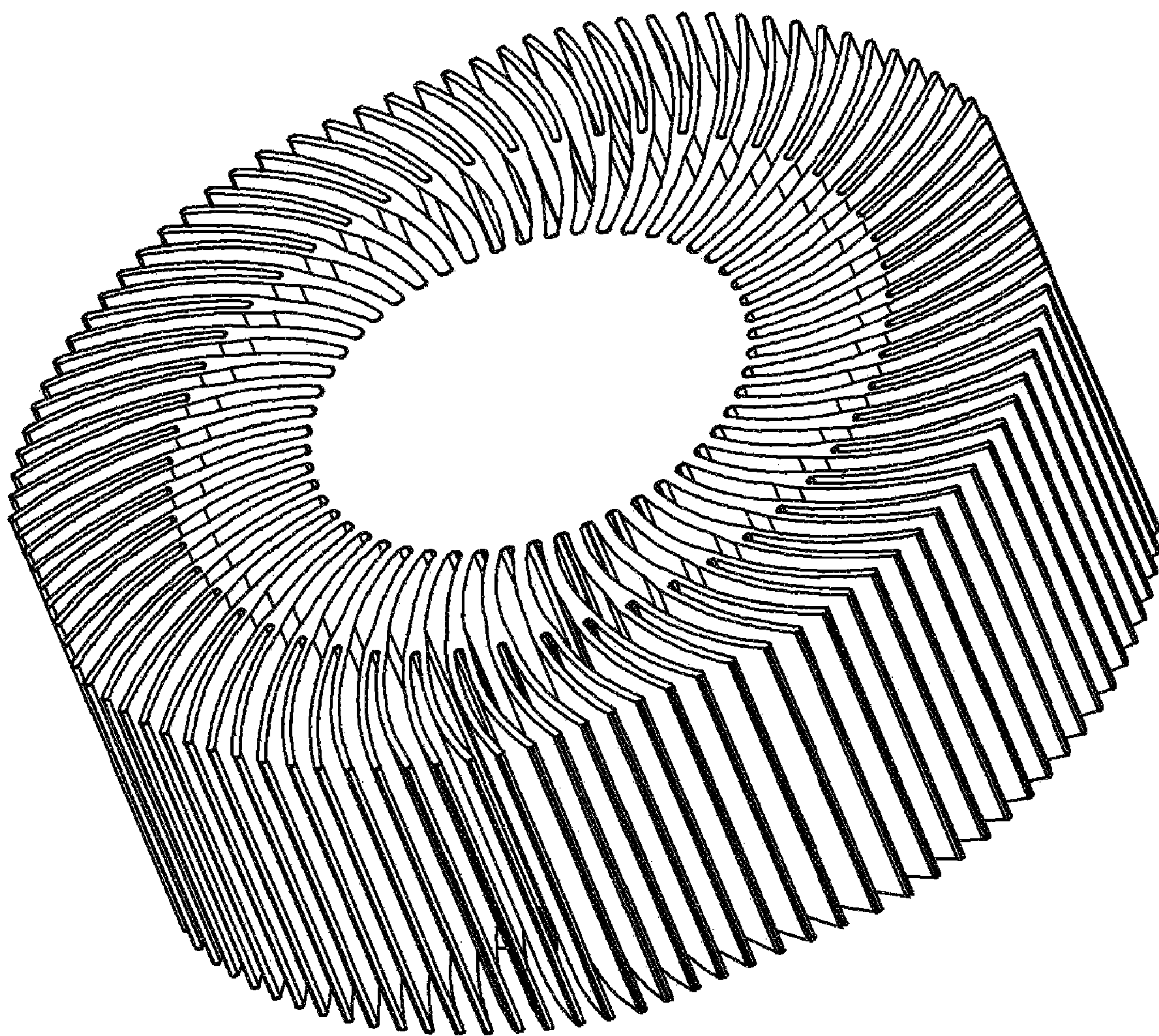

FIG. 35



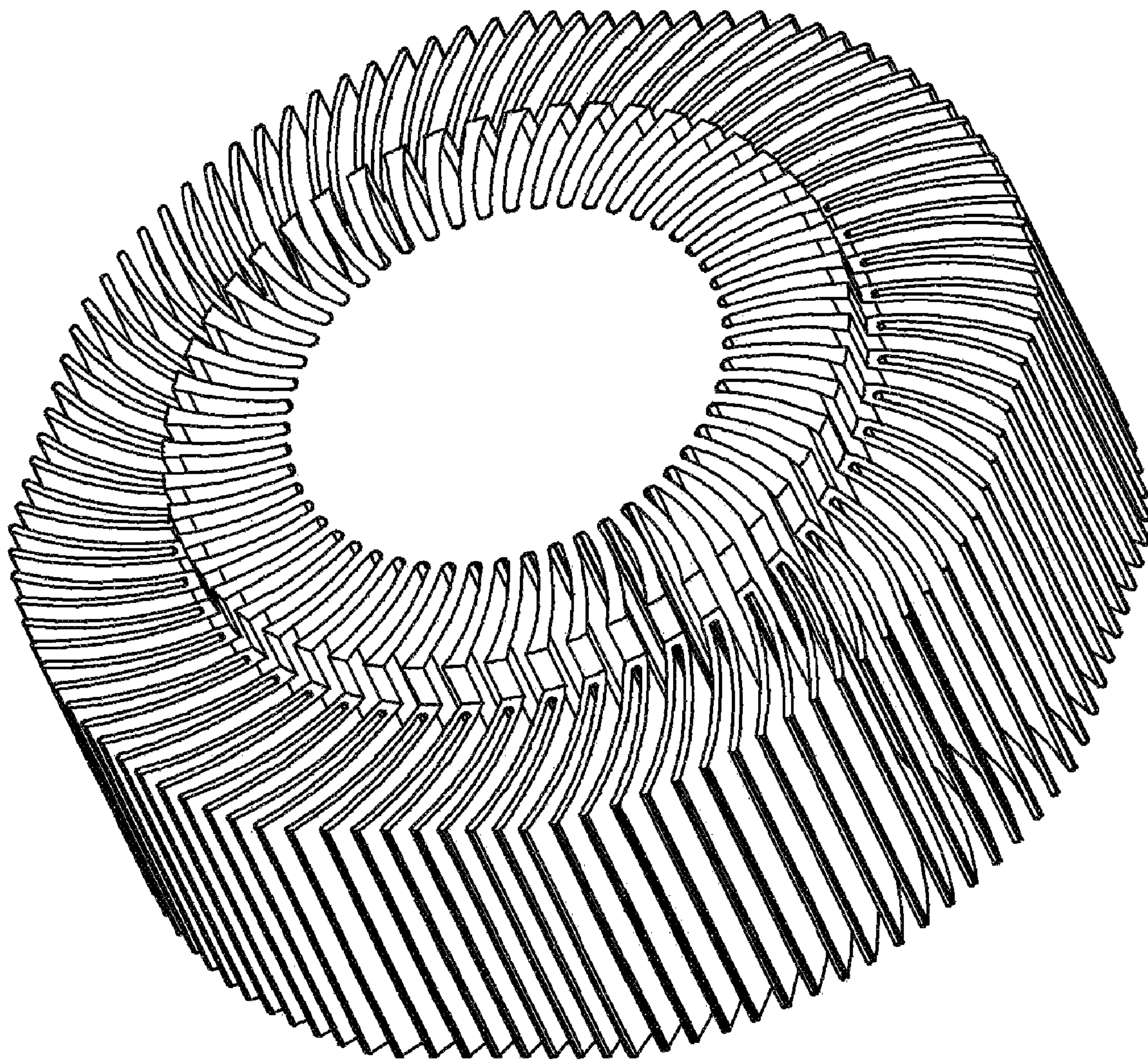

FIG. 36