



US00D600209S

(12) **United States Design Patent**
Matoba

(10) **Patent No.:** **US D600,209 S**
(45) **Date of Patent:** **** Sep. 15, 2009**

(54) **CONNECTOR FOR FLEXIBLE PRINTED CIRCUIT BOARD**

- (75) Inventor: **Masato Matoba**, Kyoto (JP)
- (73) Assignee: **Omron Corporation**, Kyoto-shi (JP)
- (**) Term: **14 Years**
- (21) Appl. No.: **29/323,525**
- (22) Filed: **Aug. 27, 2008**
- (30) **Foreign Application Priority Data**

Feb. 27, 2008 (JP) D 2008-004475
 Feb. 27, 2008 (JP) D 2008-004476

(51) **LOC (9) Cl.** **13-03**

(52) **U.S. Cl.** **D13/147**

(58) **Field of Classification Search** D13/147,
D13/154, 184; D14/432, 433, 436, 438;
439/62, 260, 325, 329, 395, 422, 492, 495,
439/499, 607-610

See application file for complete search history.

(56) **References Cited**

U.S. PATENT DOCUMENTS

D470,110 S * 2/2003 Yamane D13/147
(Continued)

FOREIGN PATENT DOCUMENTS

JP D1180010 7/2003
(Continued)

Primary Examiner—Daniel D Bui

(74) *Attorney, Agent, or Firm*—Harness, Dickey & Pierce,
P.L.C.

(57) **CLAIM**

The ornamental design for a connector for flexible printed circuit board, as shown and described.

DESCRIPTION

FIG. 1 is a top, front and right side perspective view of a connector for flexible printed circuit board showing a first embodiment of my new design;

FIG. 2 is a top, rear and left side perspective view thereof;

FIG. 3 is a bottom, rear and right side perspective view thereof;

FIG. 4 is a front elevational view thereof;

FIG. 5 is a rear elevational view thereof;

FIG. 6 is a left side view thereof;

FIG. 7 is a right side view thereof;

FIG. 8 is a top plan view thereof.

FIG. 9 is a bottom plan view thereof;

FIG. 10 is a perspective cross-sectional view taken along the line of X—X of FIG. 8;

FIG. 11 is a cross-sectional perspective view taken along the line of XI—XI of FIG. 8;

FIG. 12 is a top, front and right side perspective view thereof, shown in an alternate position of use;

FIG. 13 is a top, rear and left side perspective view thereof;

FIG. 14 is a front elevational view thereof;

FIG. 15 is a top plan view thereof;

FIG. 16 is a top, front and right side perspective view of a connector for flexible printed circuit board showing a second embodiment of my new design;

FIG. 17 is a top, rear and left side perspective view thereof.

FIG. 18 is a bottom, rear and right side perspective view thereof;

FIG. 19 is a front elevational view thereof;

FIG. 20 is a rear elevational view thereof

FIG. 21 is a left side view thereof;

FIG. 22 is a right side view thereof;

FIG. 23 is a top plan view thereof;

FIG. 24 is a bottom plan view thereof;

FIG. 25 is a perspective cross-sectional view taken along the line of XXV of FIG. 23

FIG. 26 is a perspective cross-sectional view taken along the line of XXVI of FIG. 23.

FIG. 27 is a top, front and right side perspective view thereof, shown in an alternate position;

FIG. 28 is a top, rear and left side perspective view prospective thereof;

FIG. 29 is a front elevational view thereof; and,

FIG. 30 is a top plan view thereof.

1 Claim, 26 Drawing Sheets

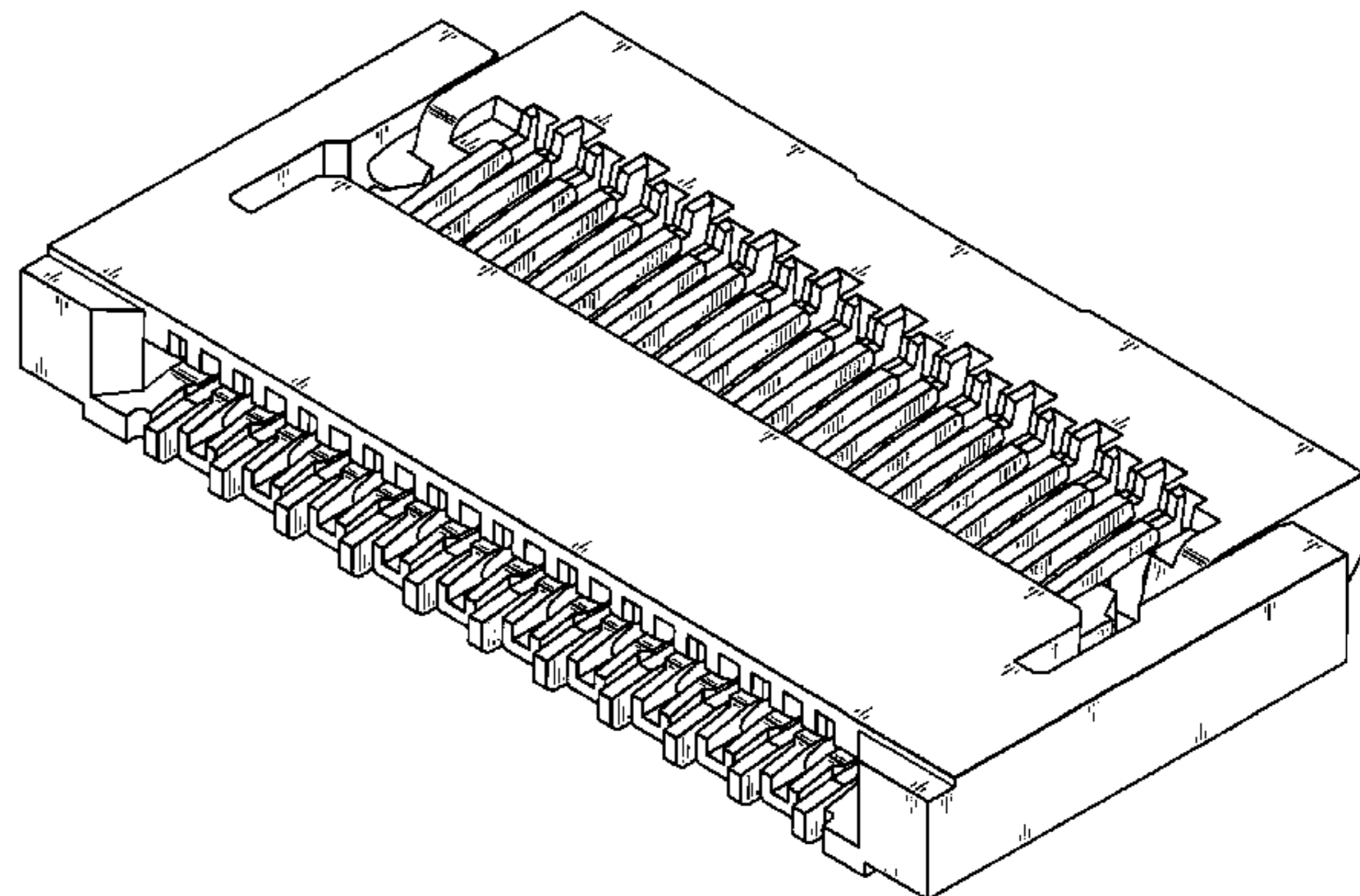
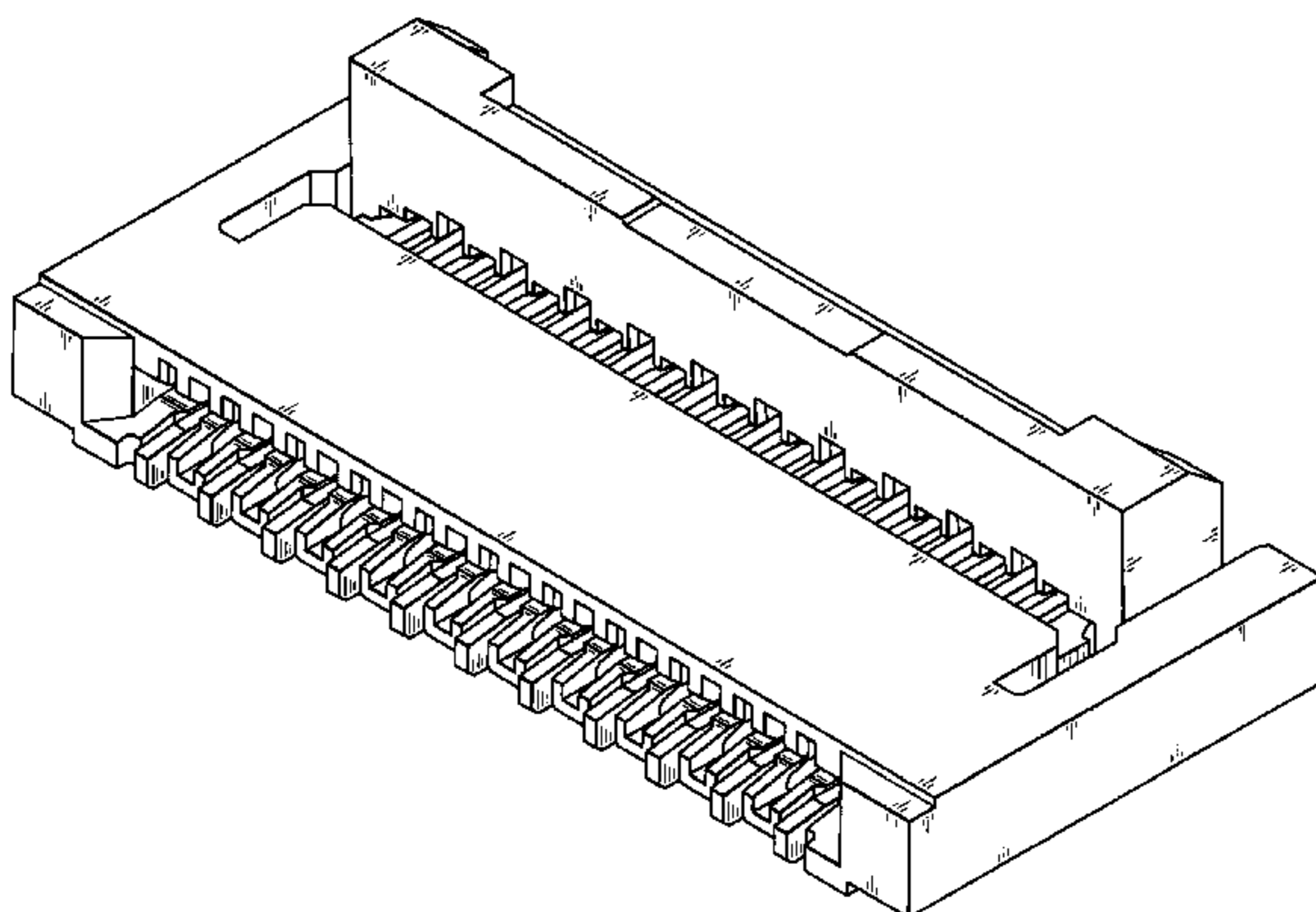

US D600,209 S

Page 2

U.S. PATENT DOCUMENTS

D472,219 S * 3/2003 Miura D13/147
D482,327 S * 11/2003 Saito et al. D13/147
D500,985 S * 1/2005 Yamane et al. D13/147
D501,183 S * 1/2005 Yamane et al. D13/147
D517,494 S * 3/2006 Ikenaga et al. D13/147
D582,853 S * 12/2008 Peng et al. D13/147
D589,885 S * 4/2009 Wu D13/147

2006/0105622 A1* 5/2006 Nakano et al. 439/495

FOREIGN PATENT DOCUMENTS

JP D1180302 7/2003
JP D1233430 3/2005
JP D1250913 9/2005
JP D1251412 9/2005

* cited by examiner

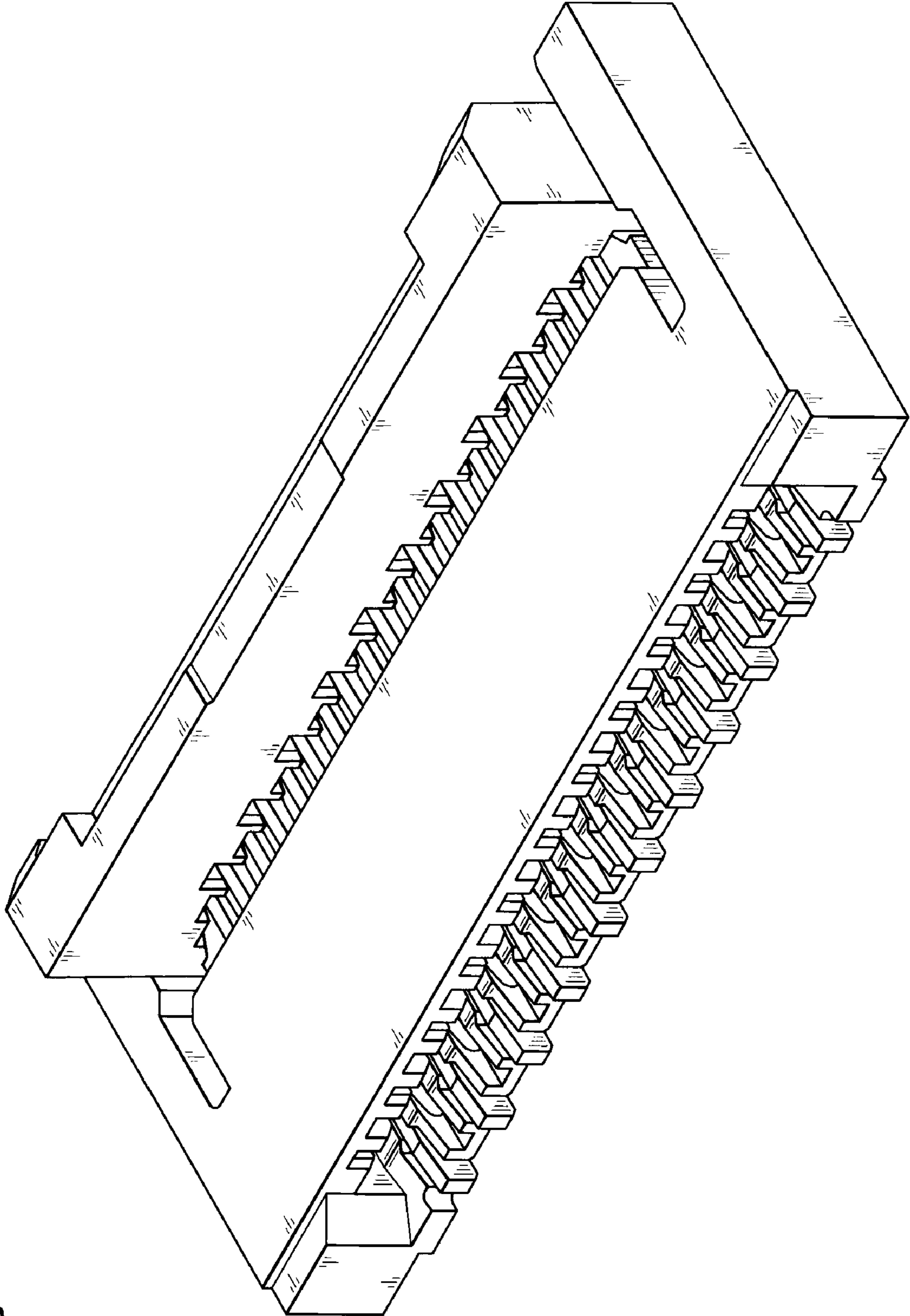

Fig. 1

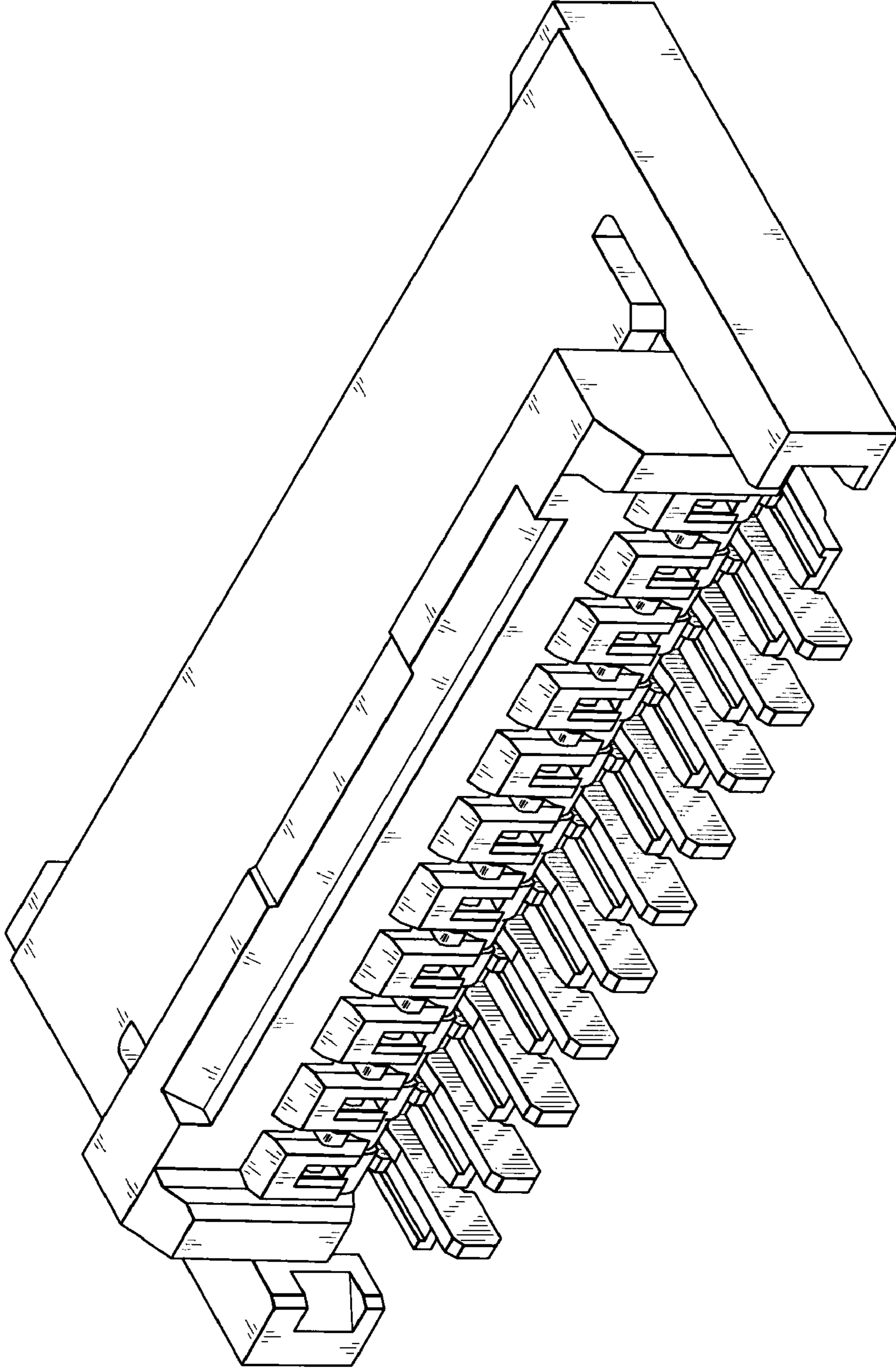

Fig. 2

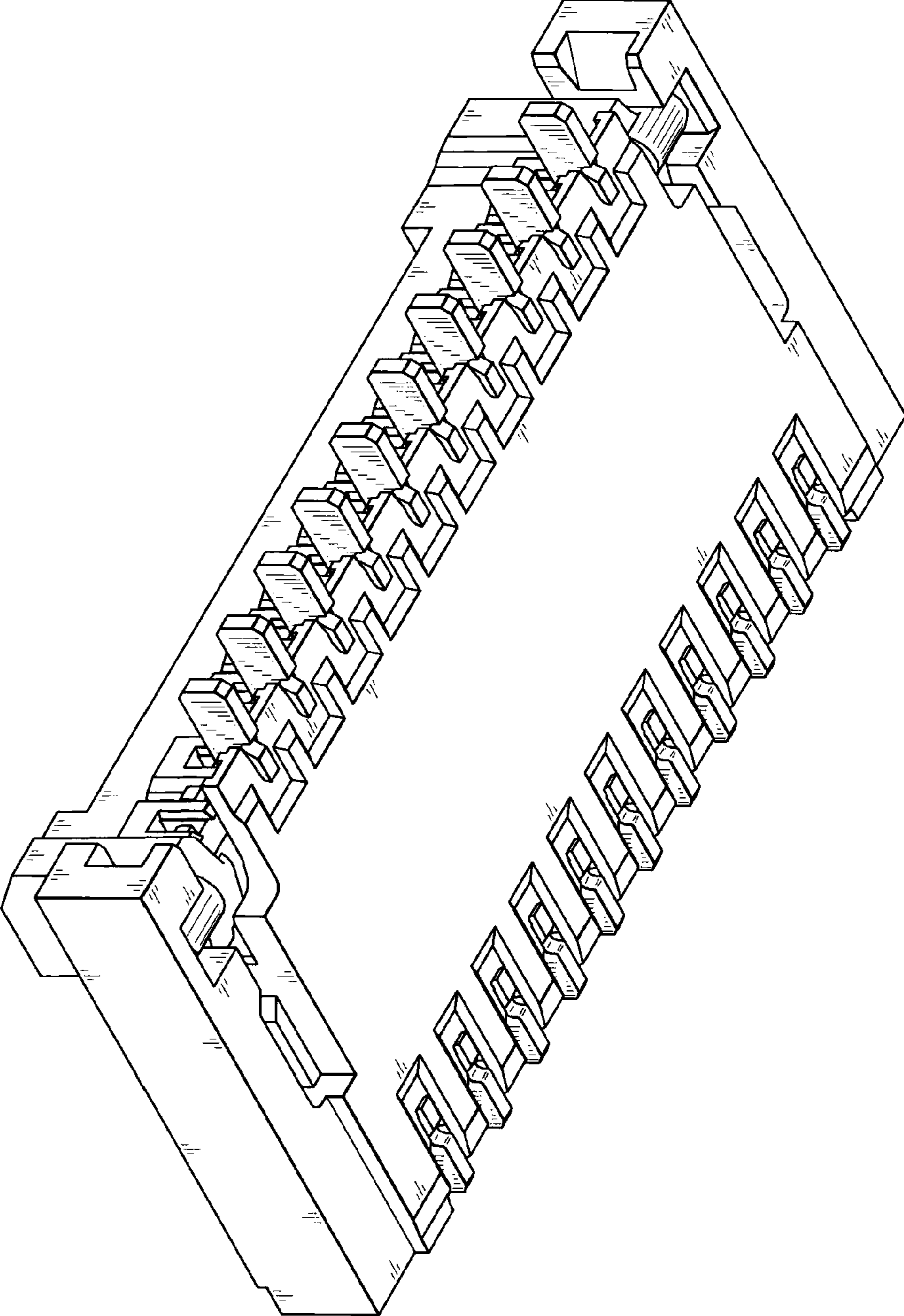

Fig. 3

Fig. 4

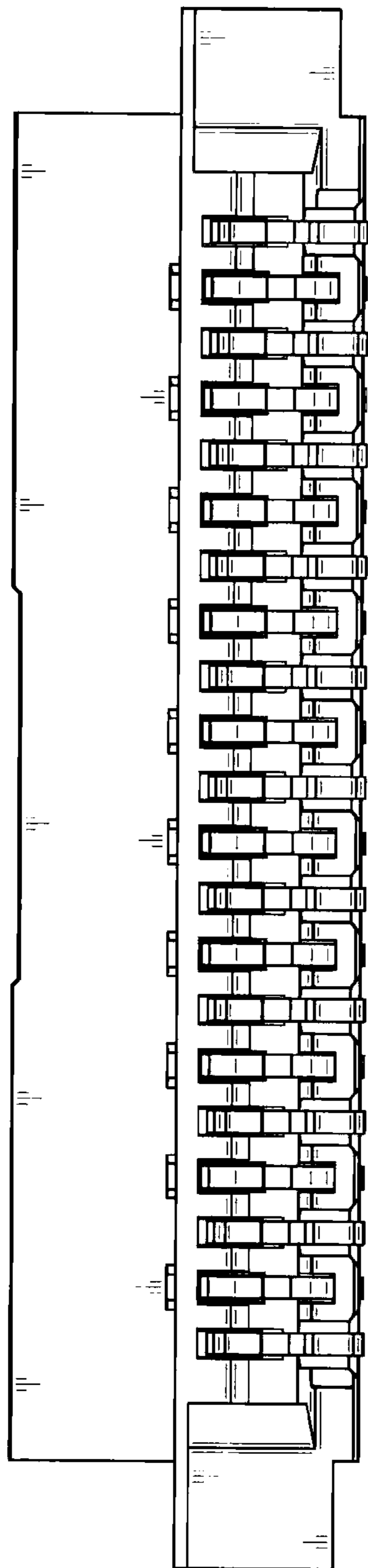

Fig. 5

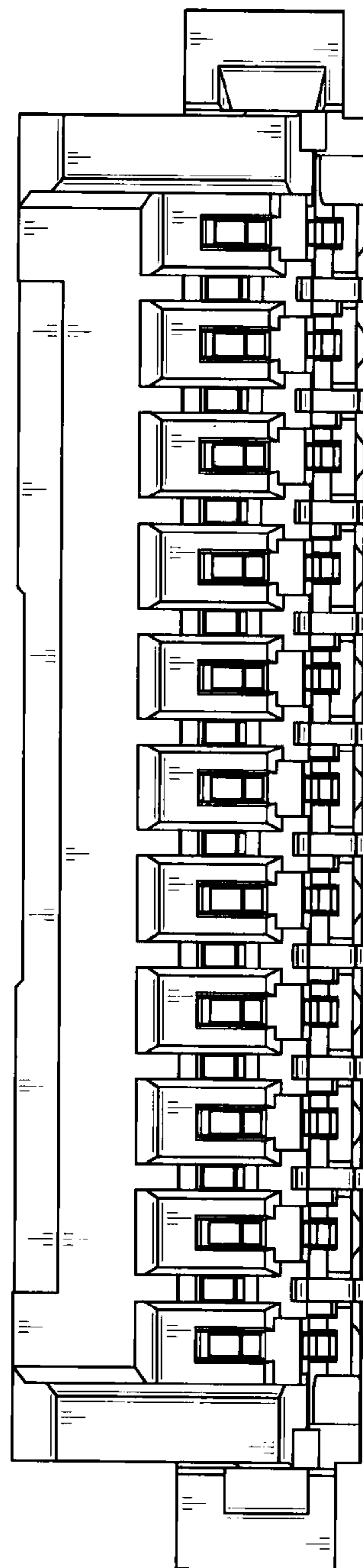

Fig. 7

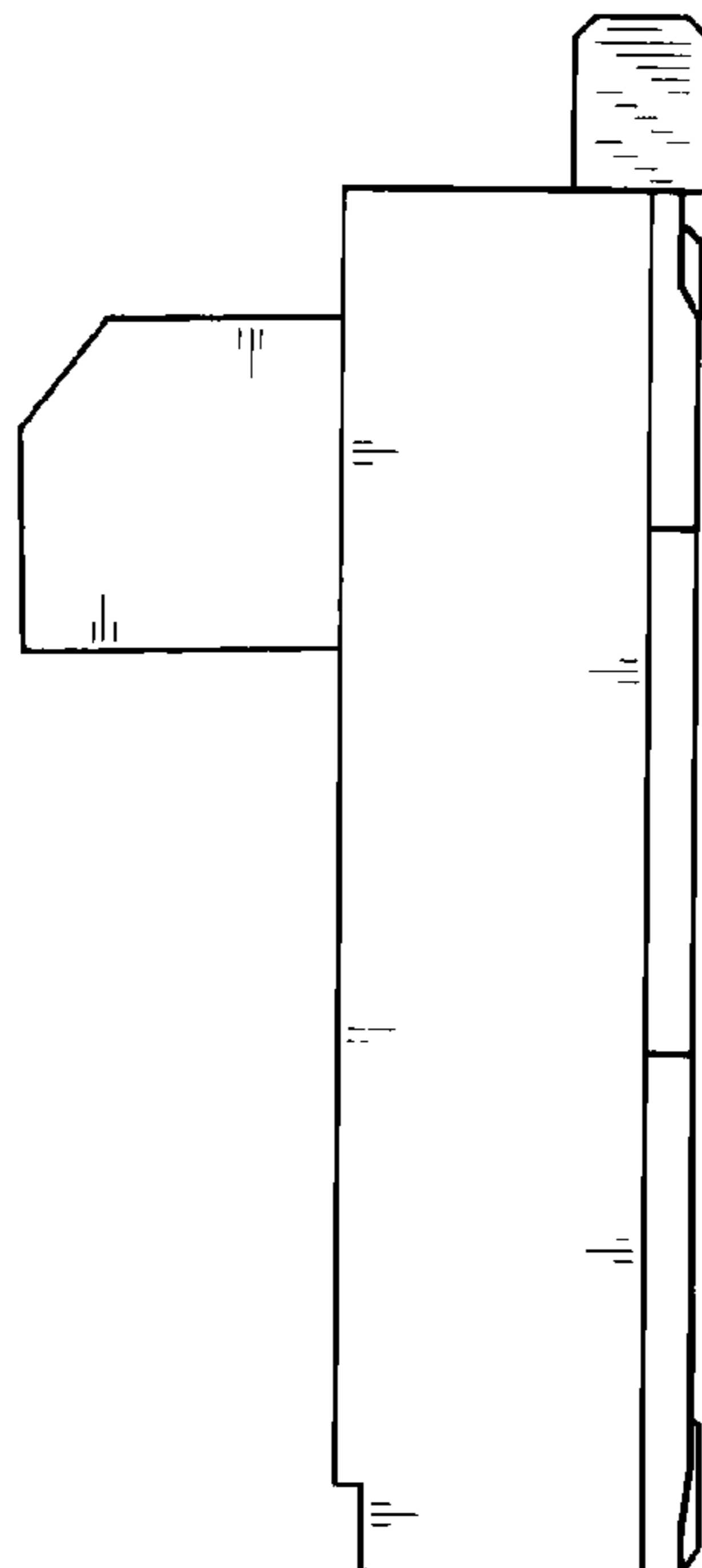

Fig. 6

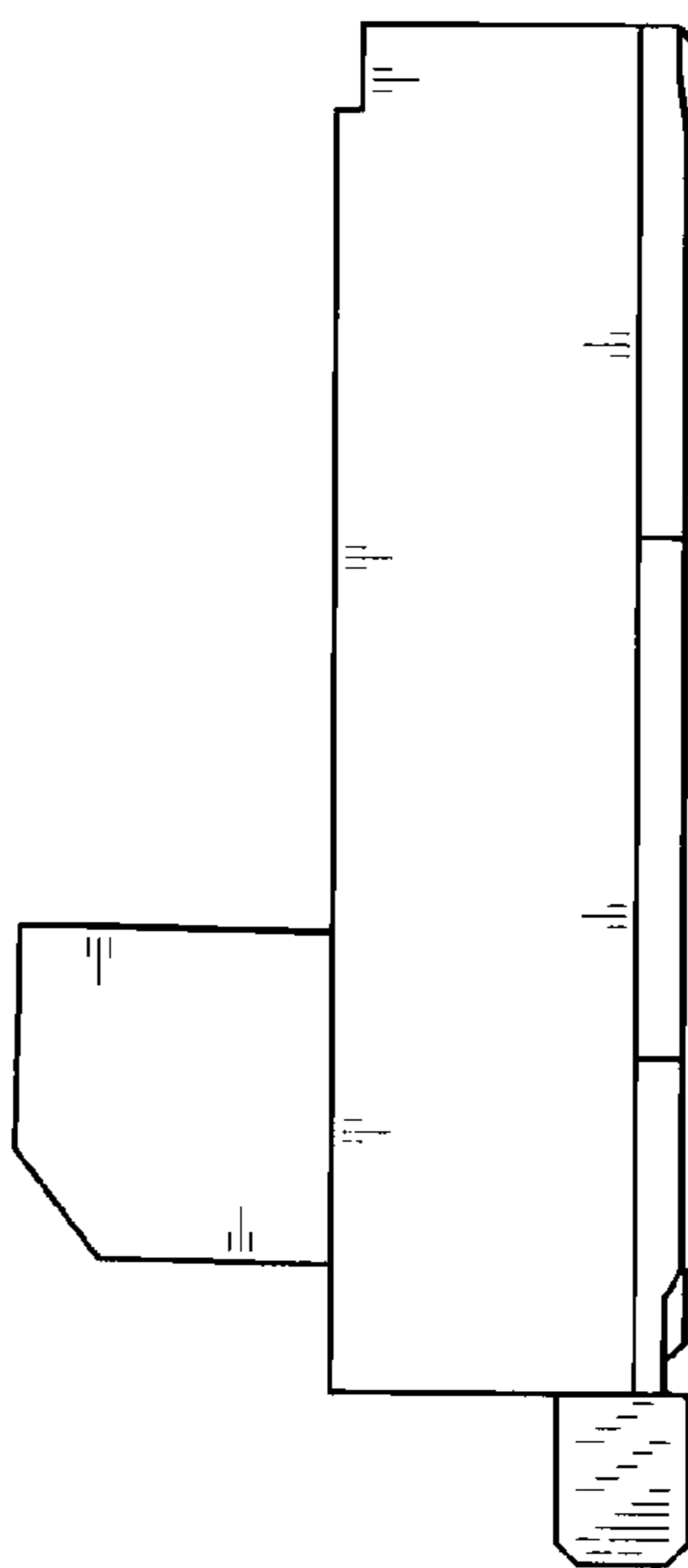
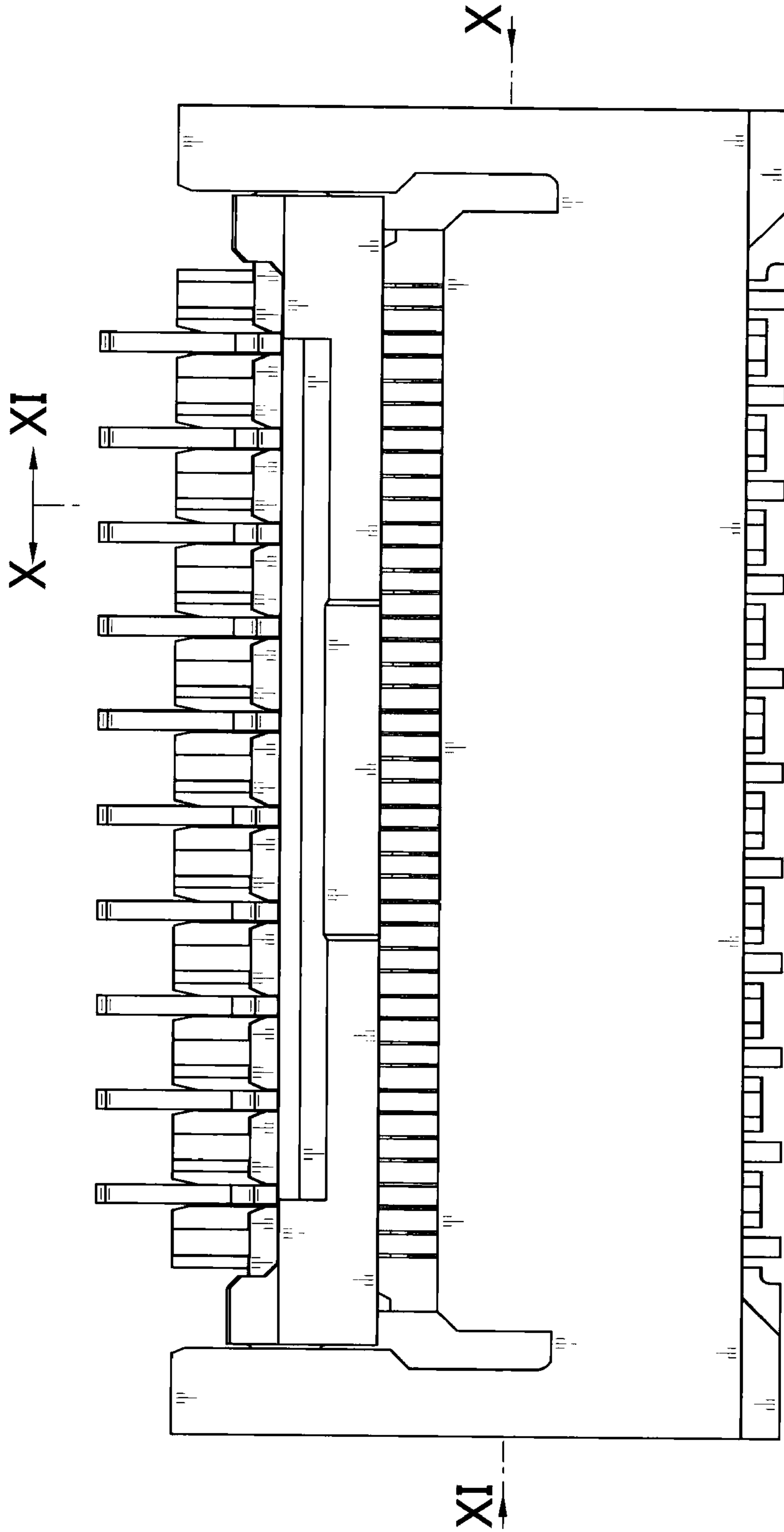

Fig. 8



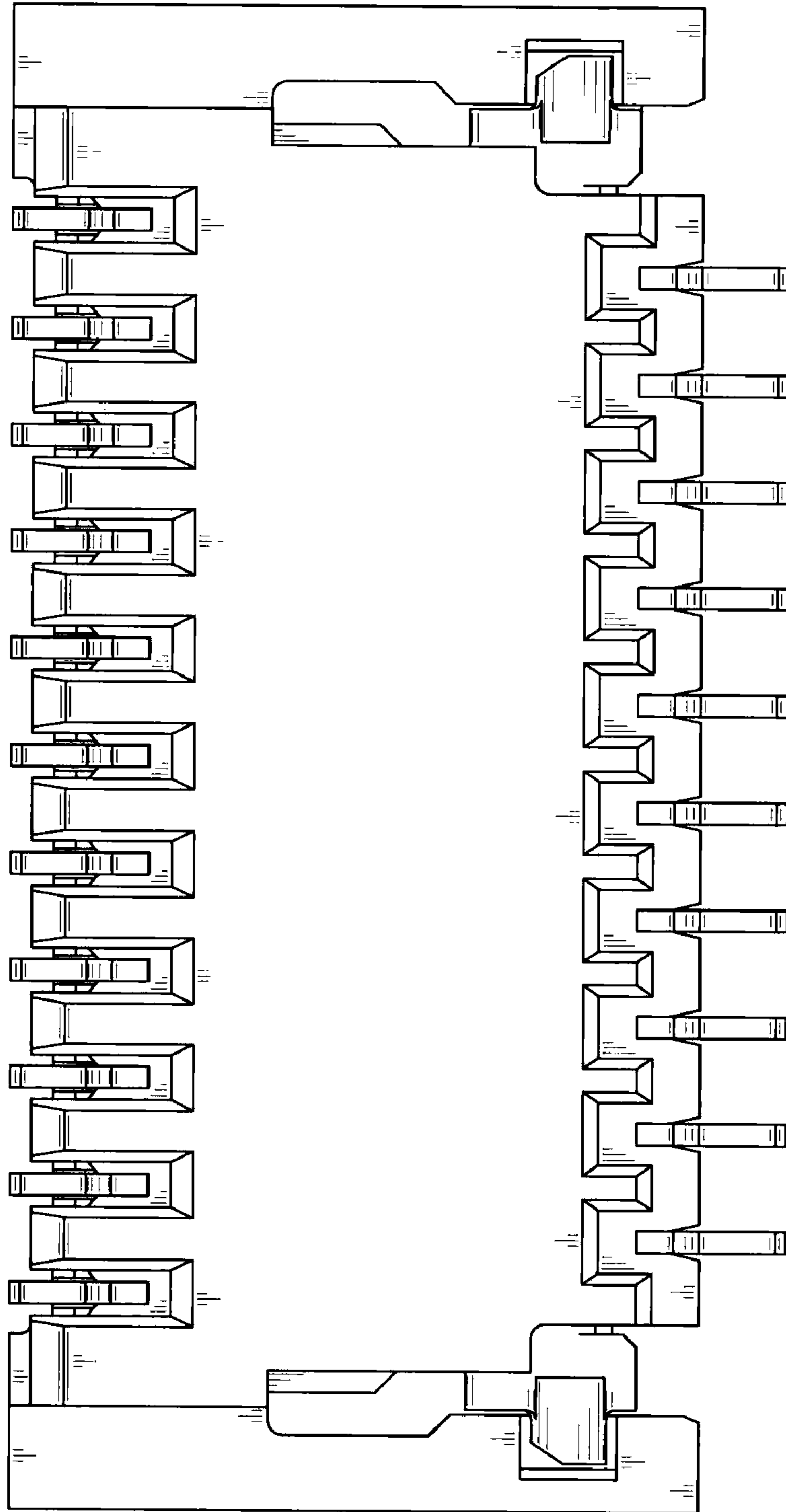

Fig. 9

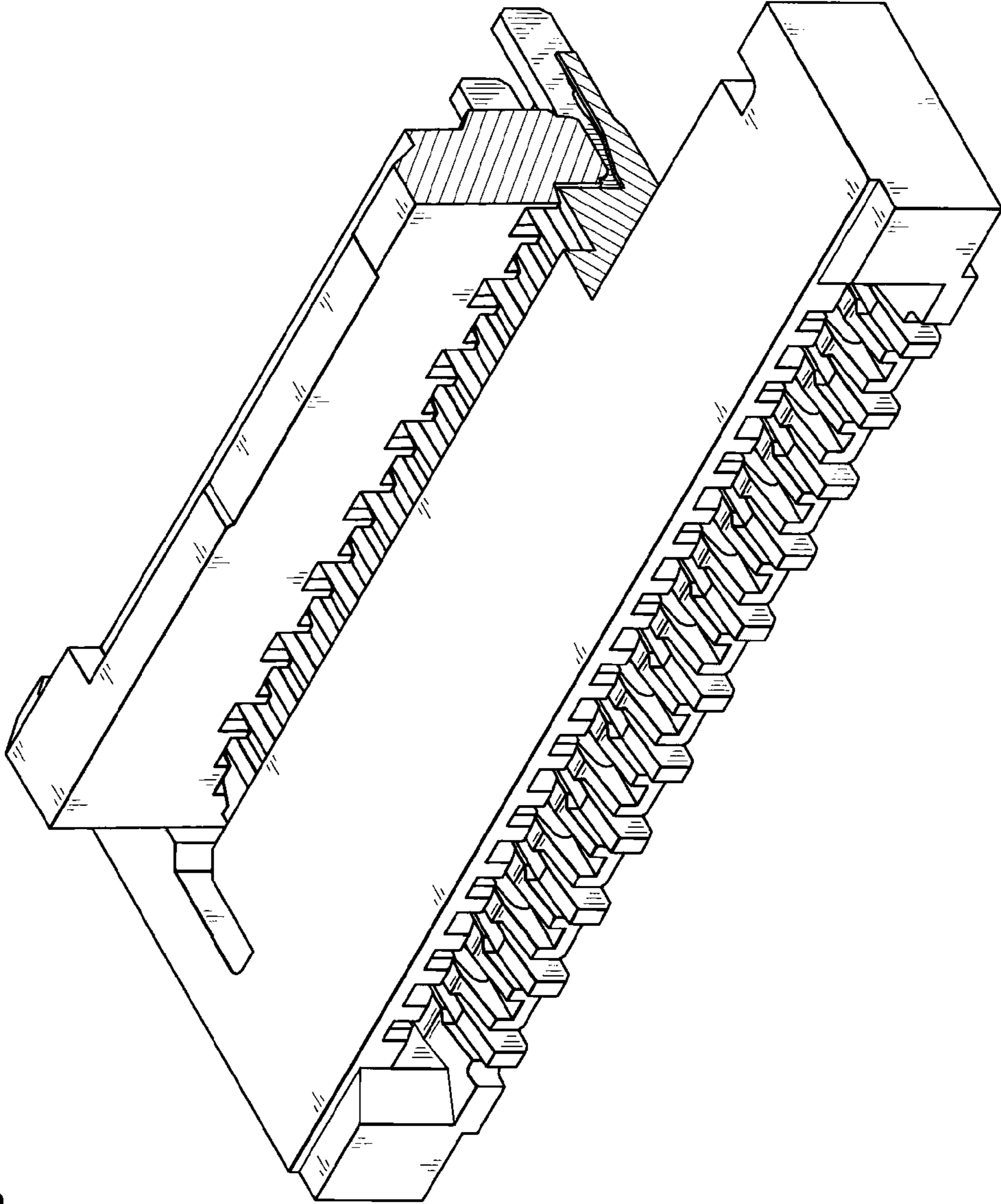

Fig. 10

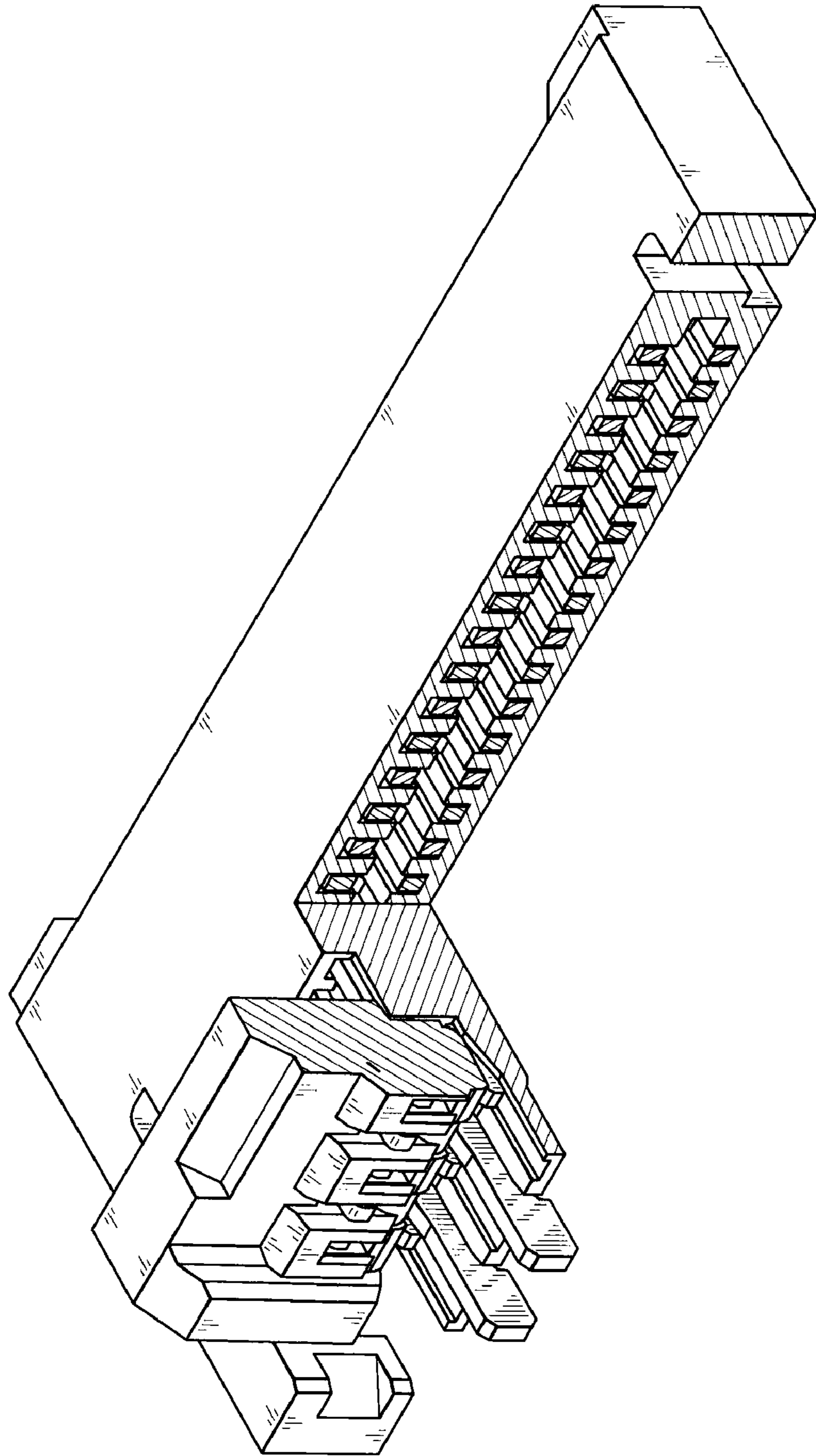

Fig. 11

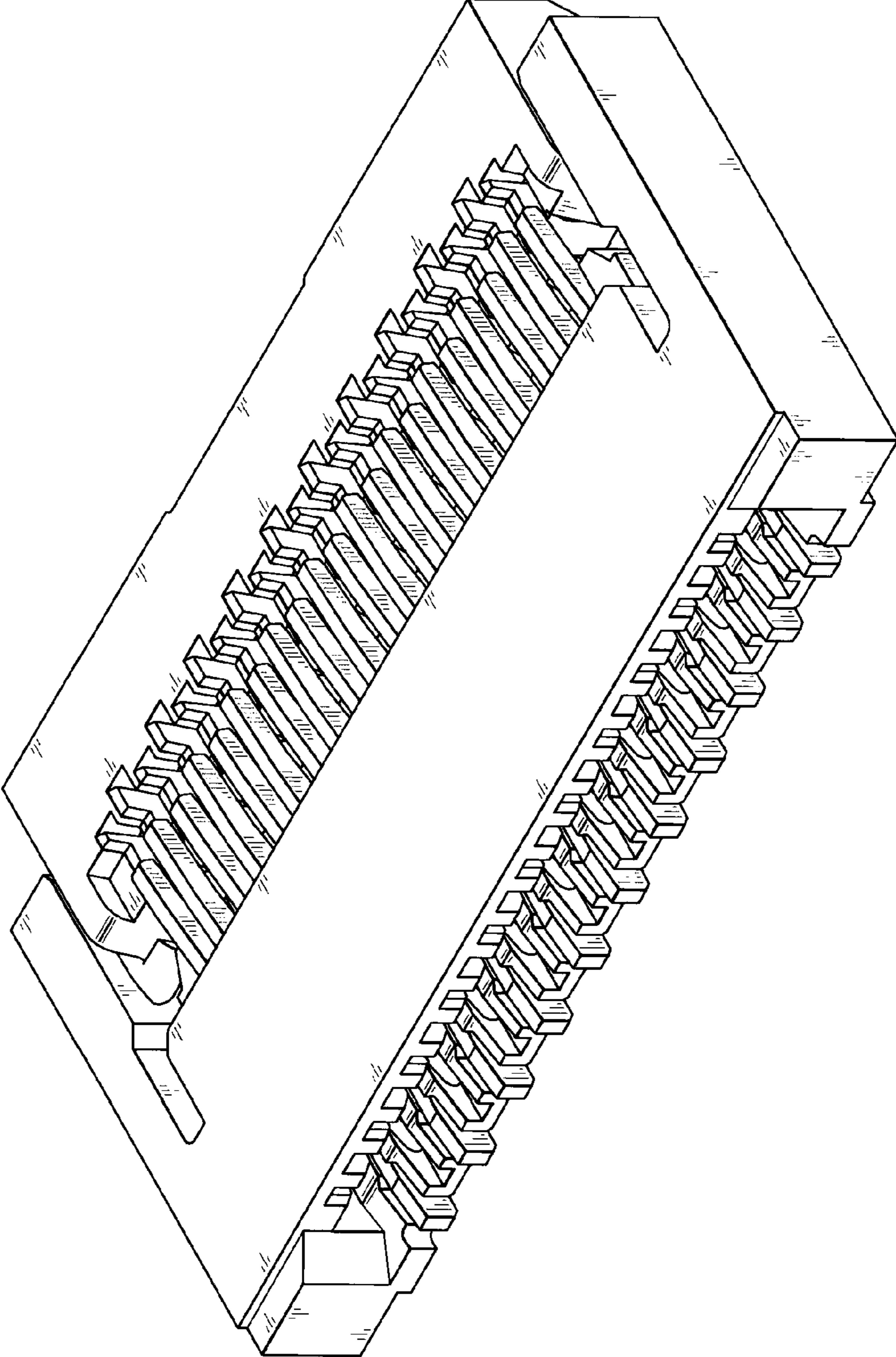

Fig. 12

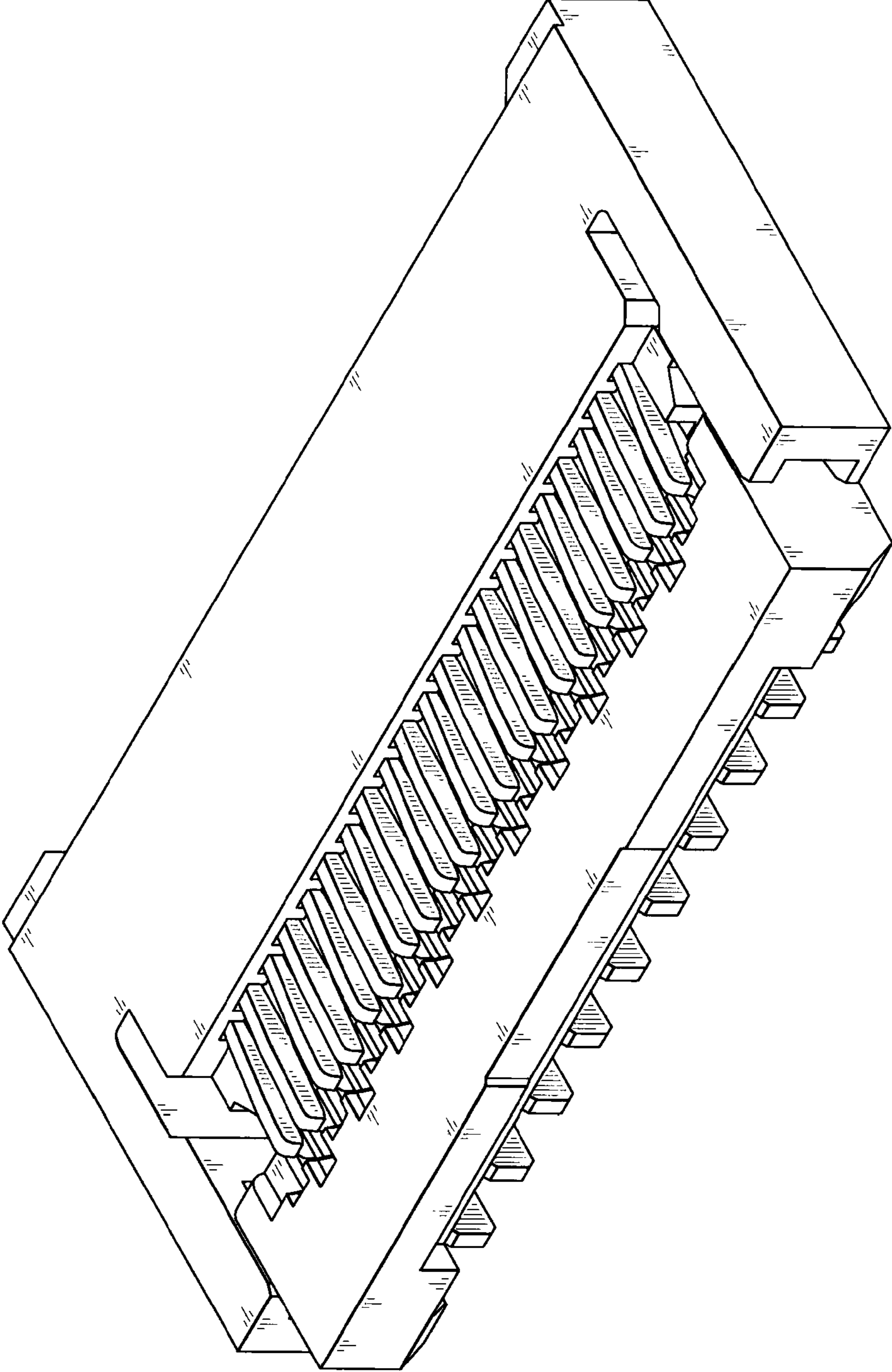

Fig. 13

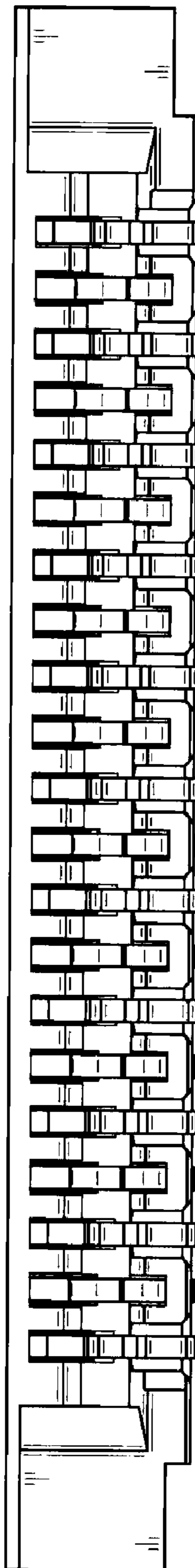
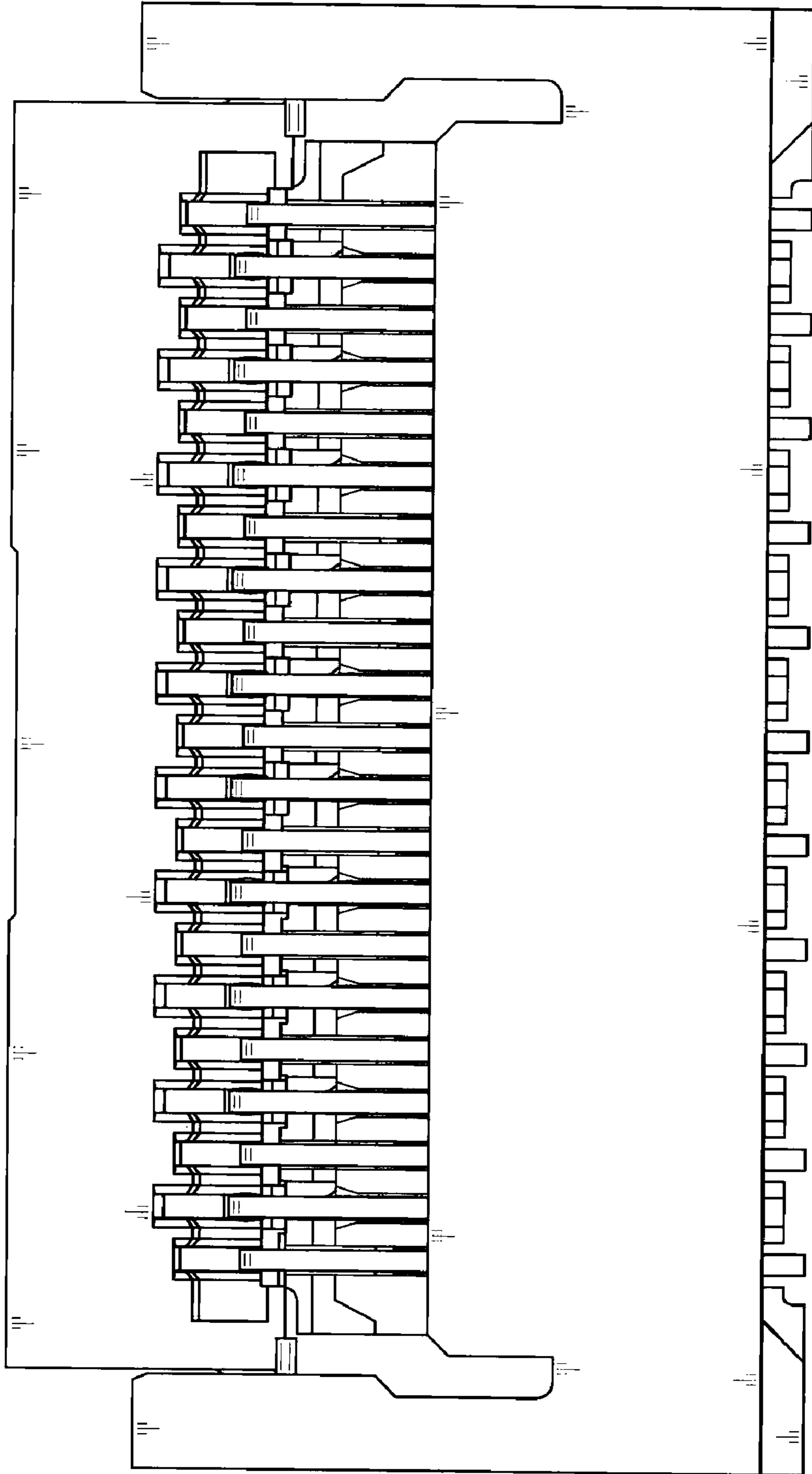

Fig. 14

Fig. 15



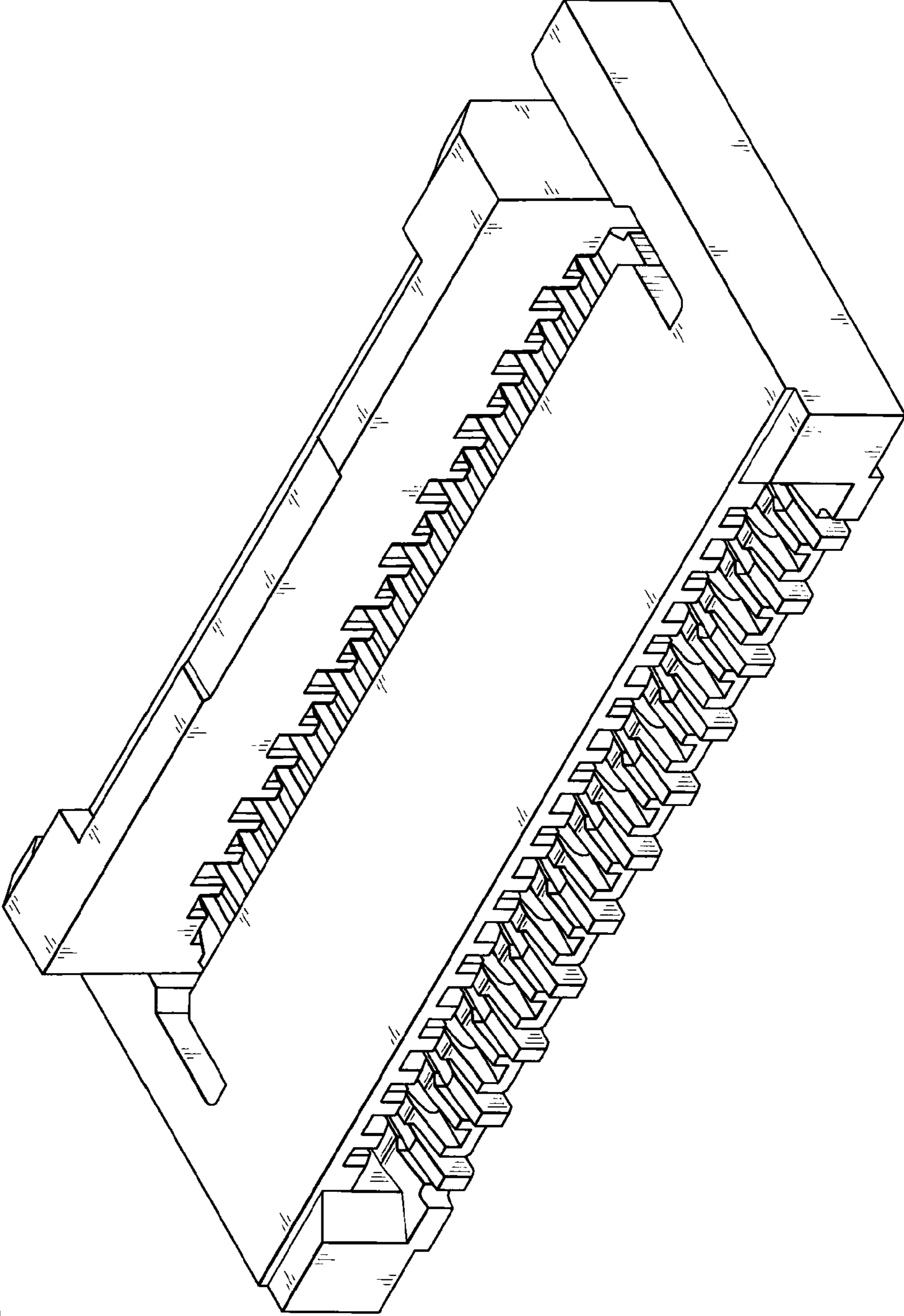

Fig. 16

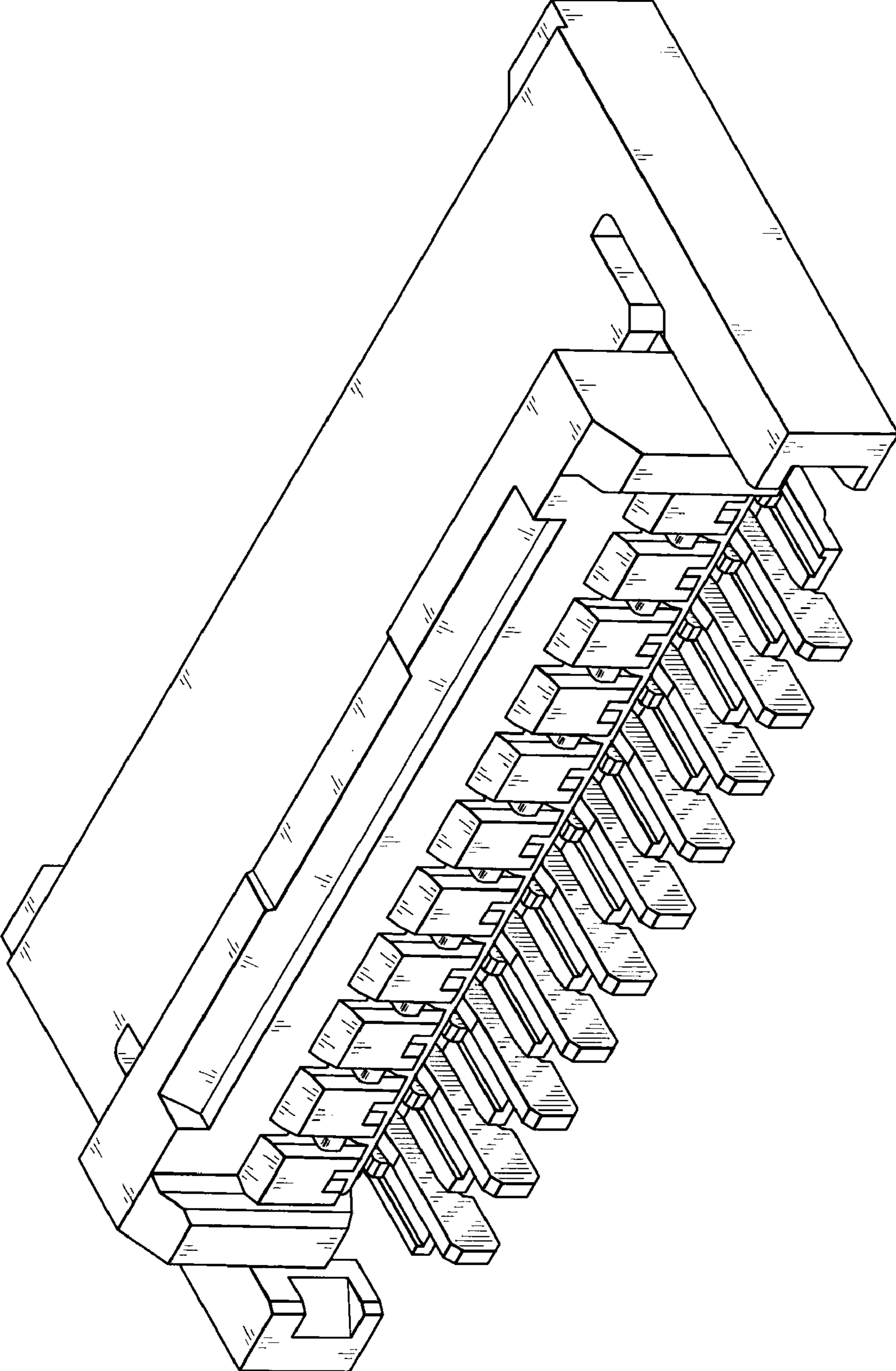

Fig. 17

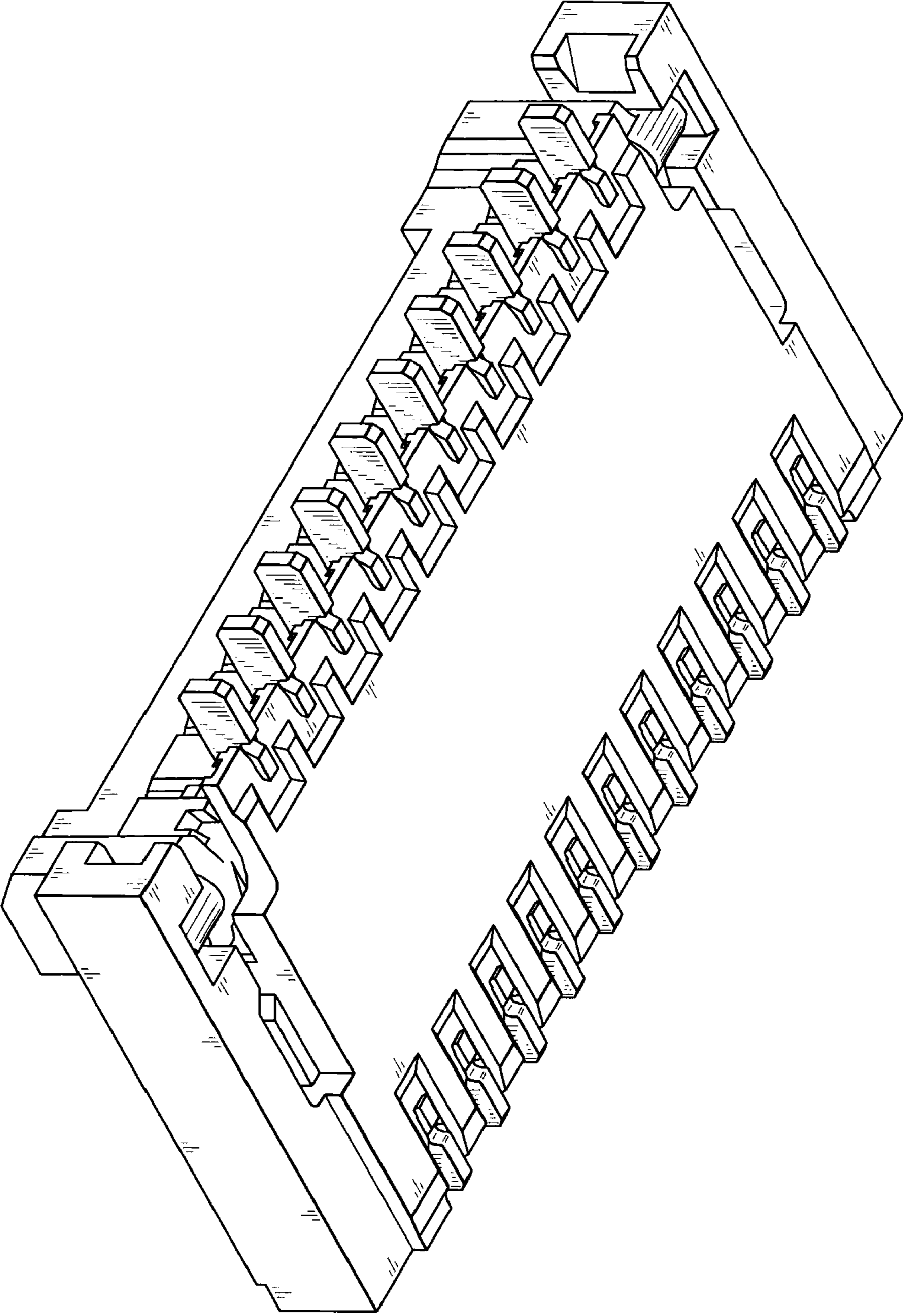

Fig. 18

Fig. 19

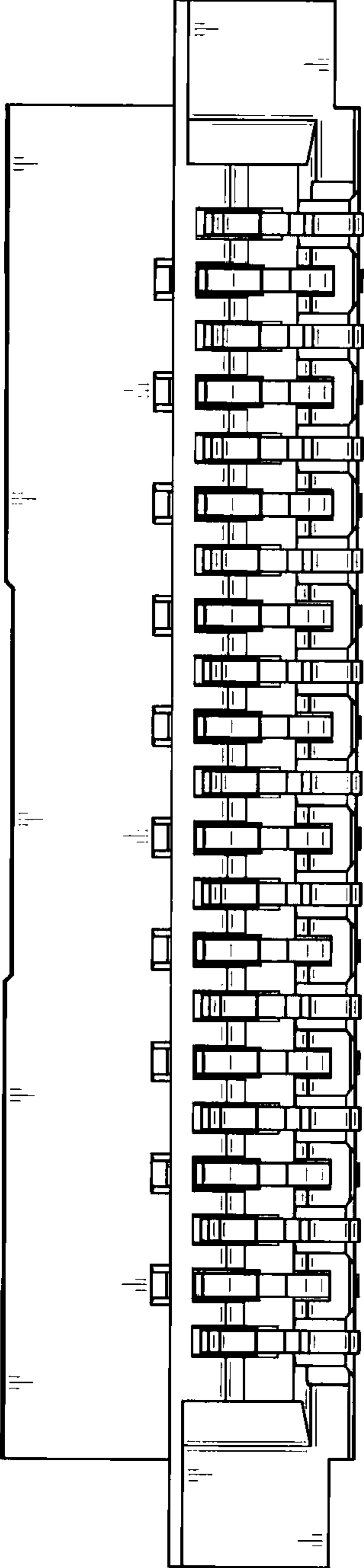

Fig. 20

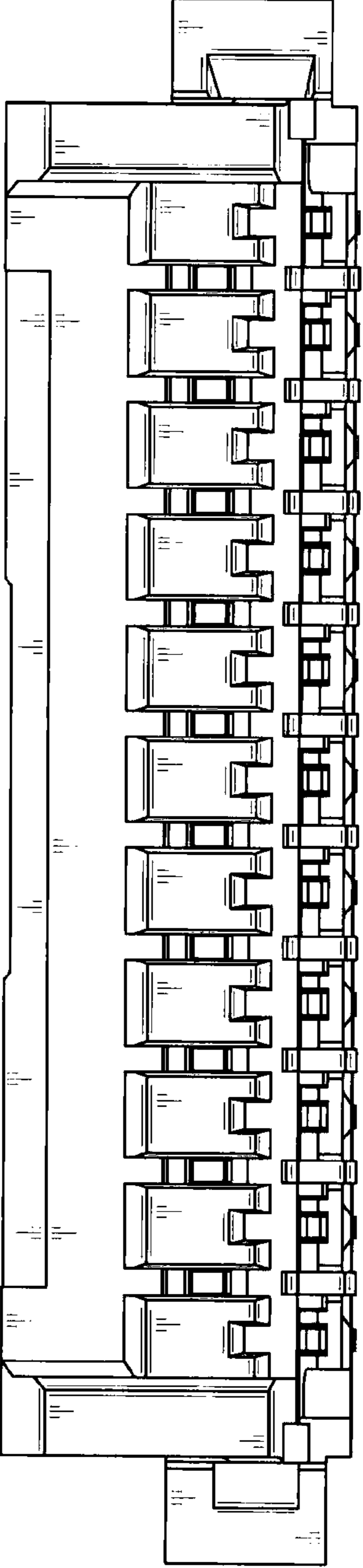

Fig. 22

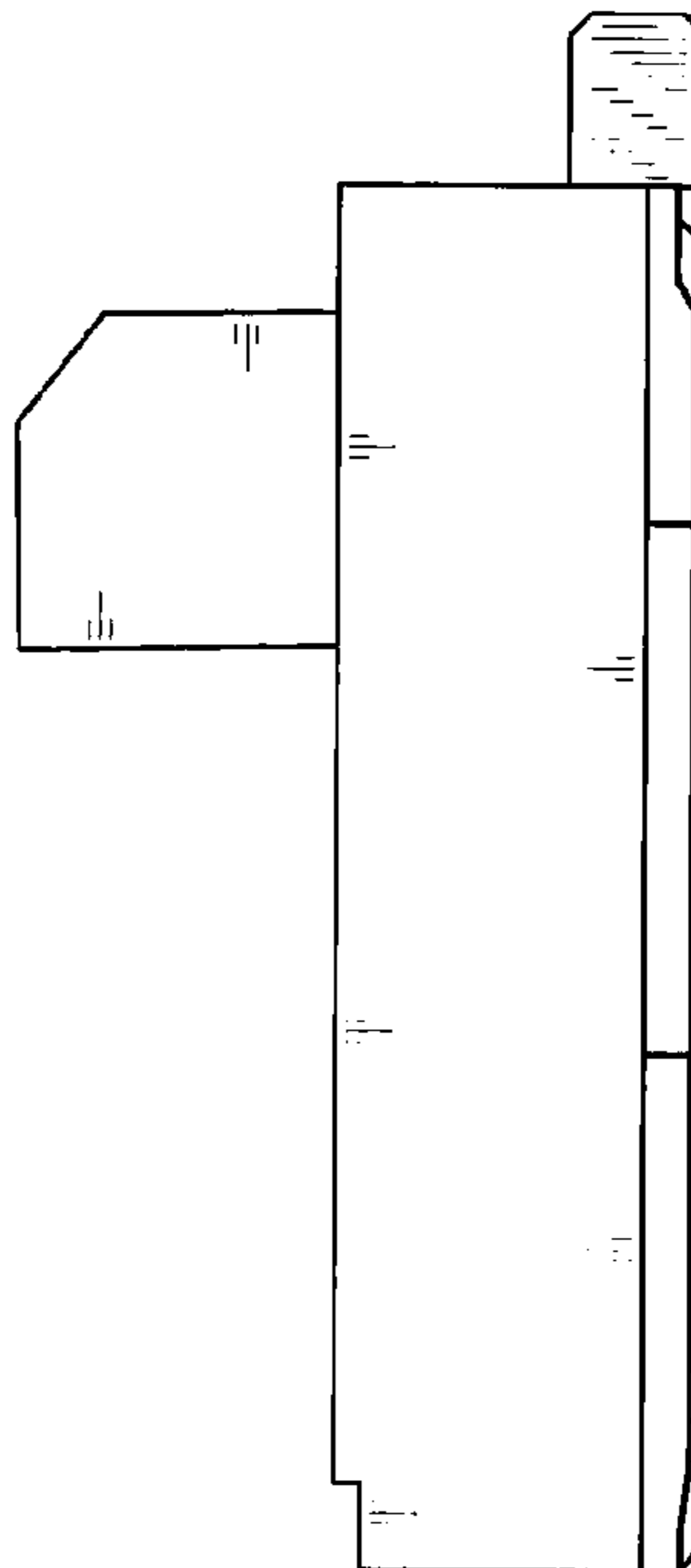

Fig. 21

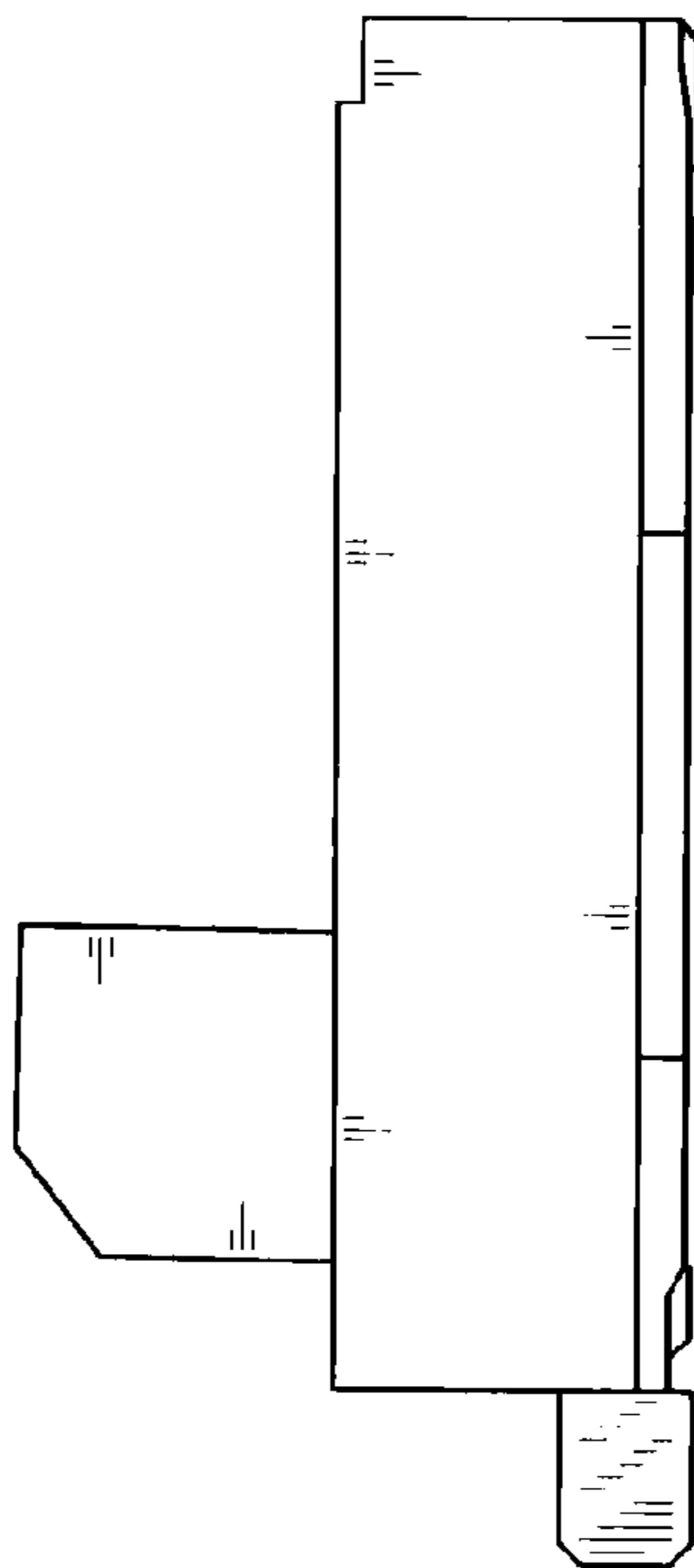

Fig. 23

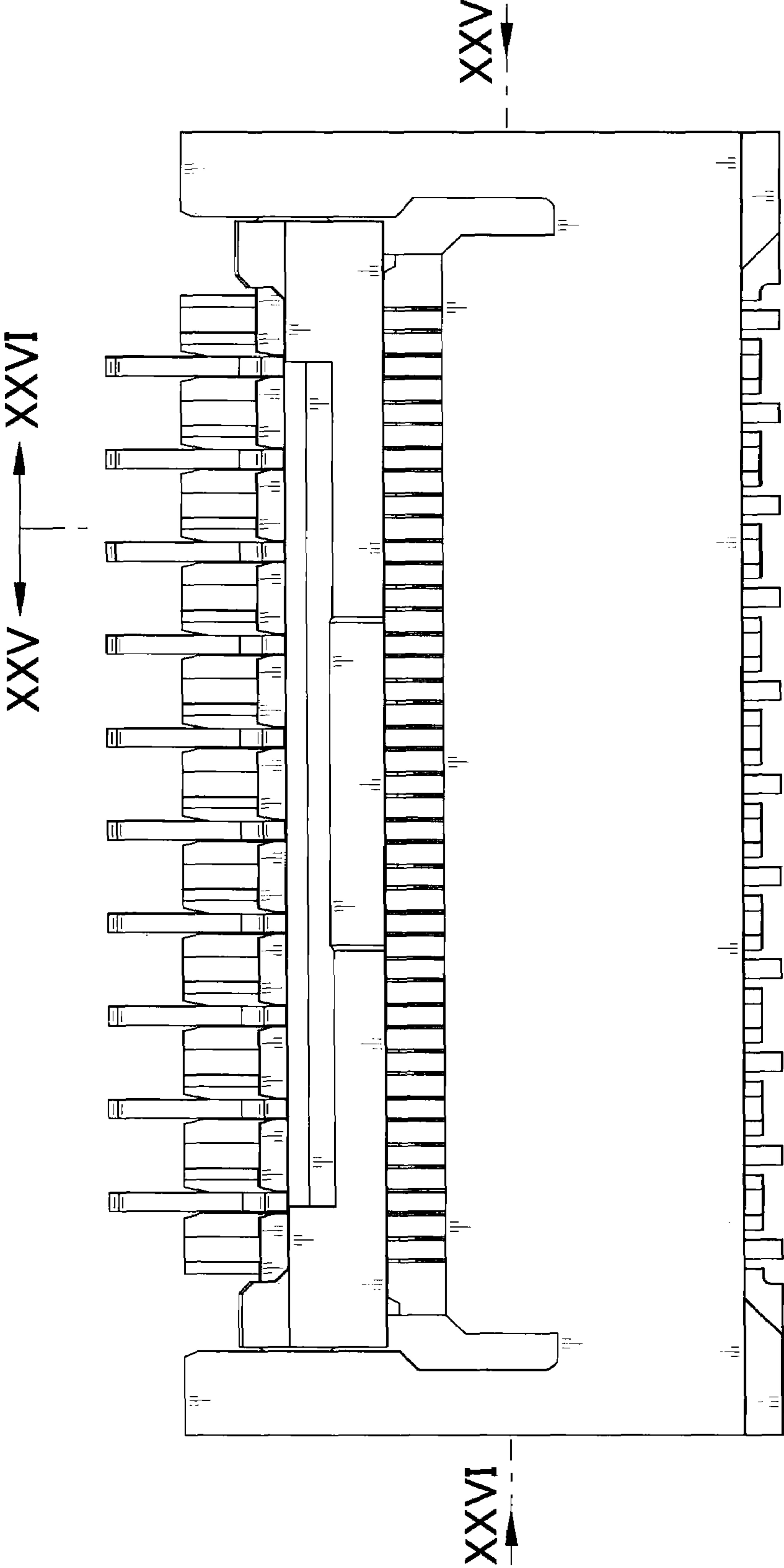
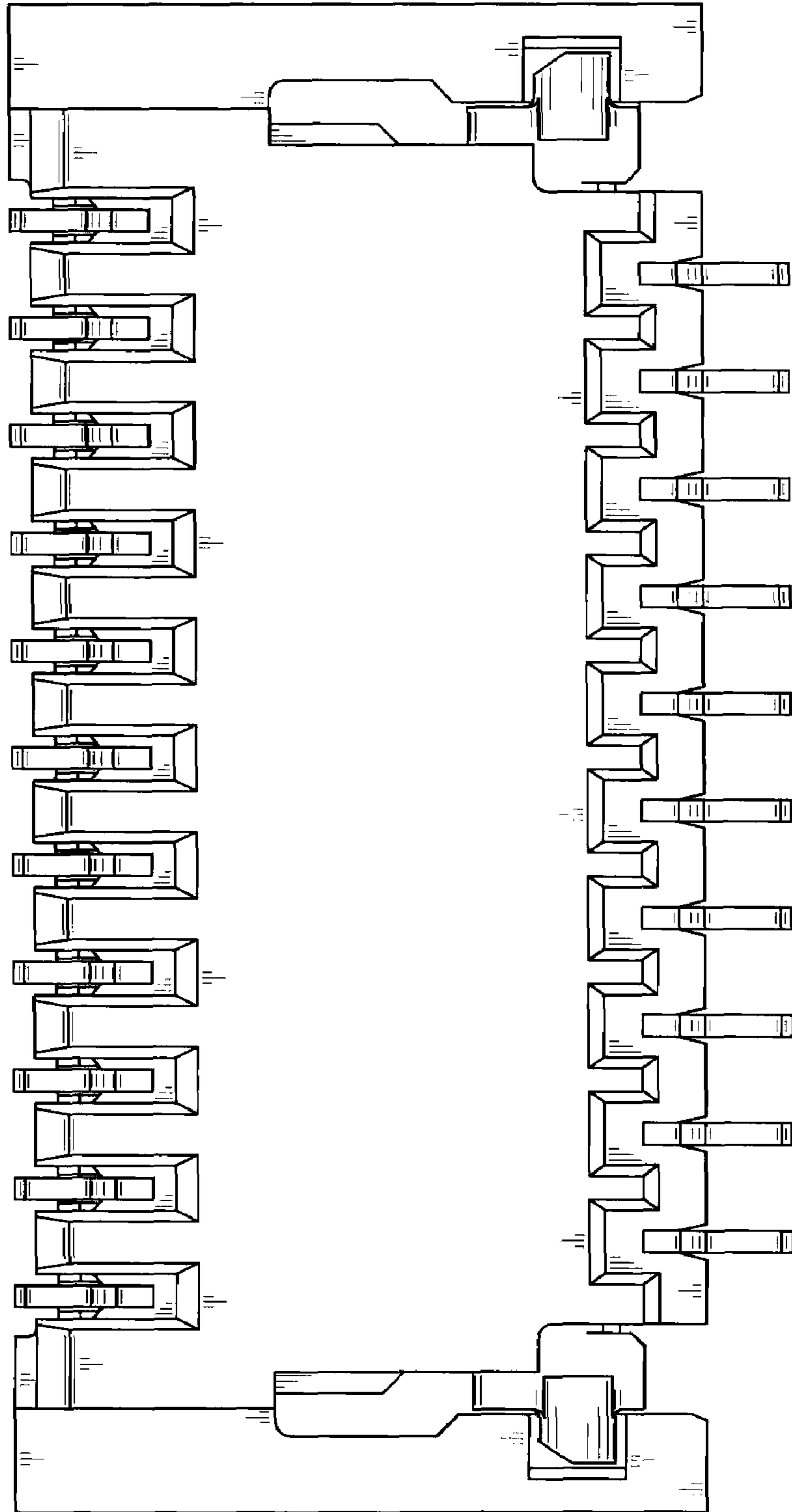

Fig. 24



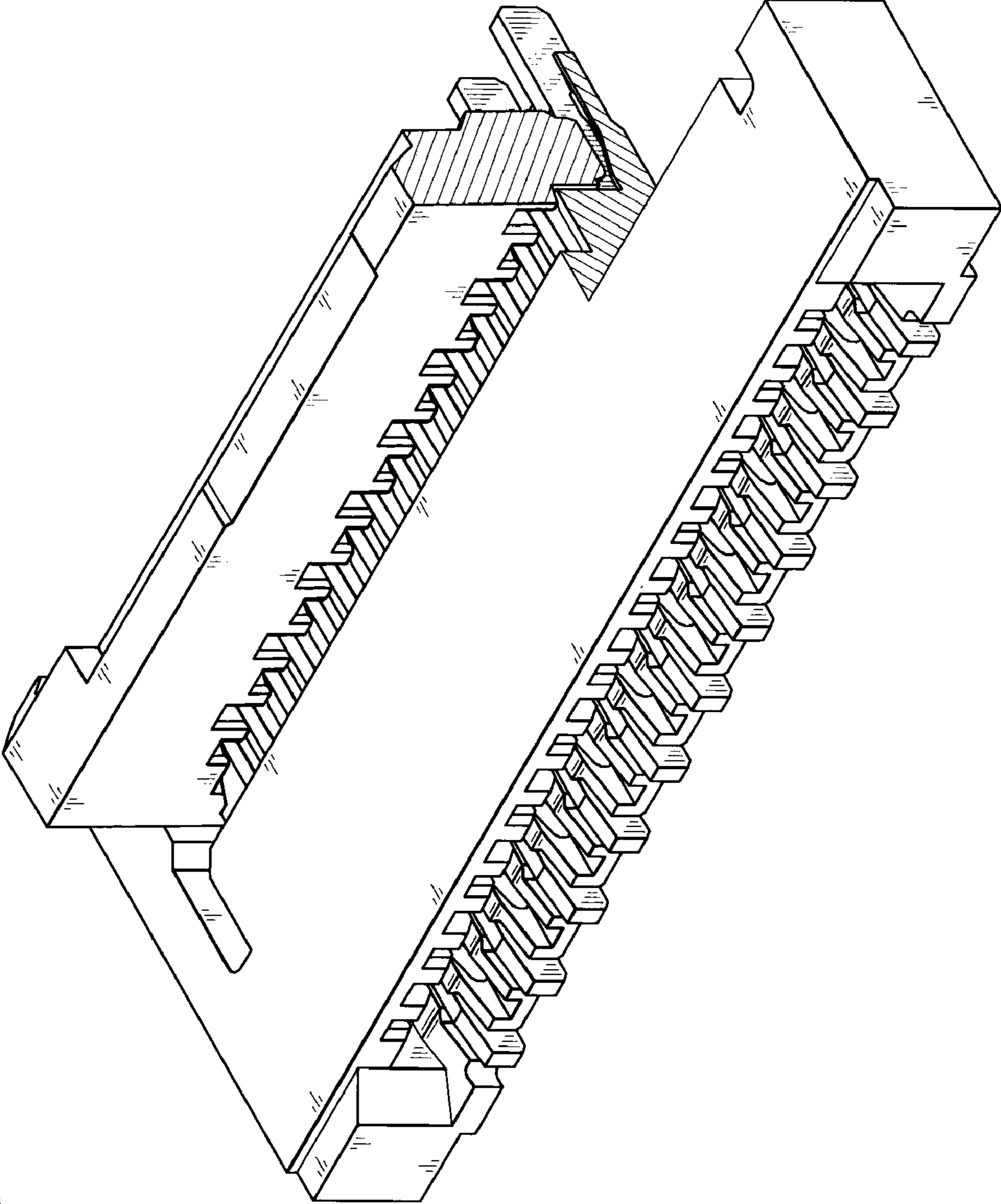

Fig. 25

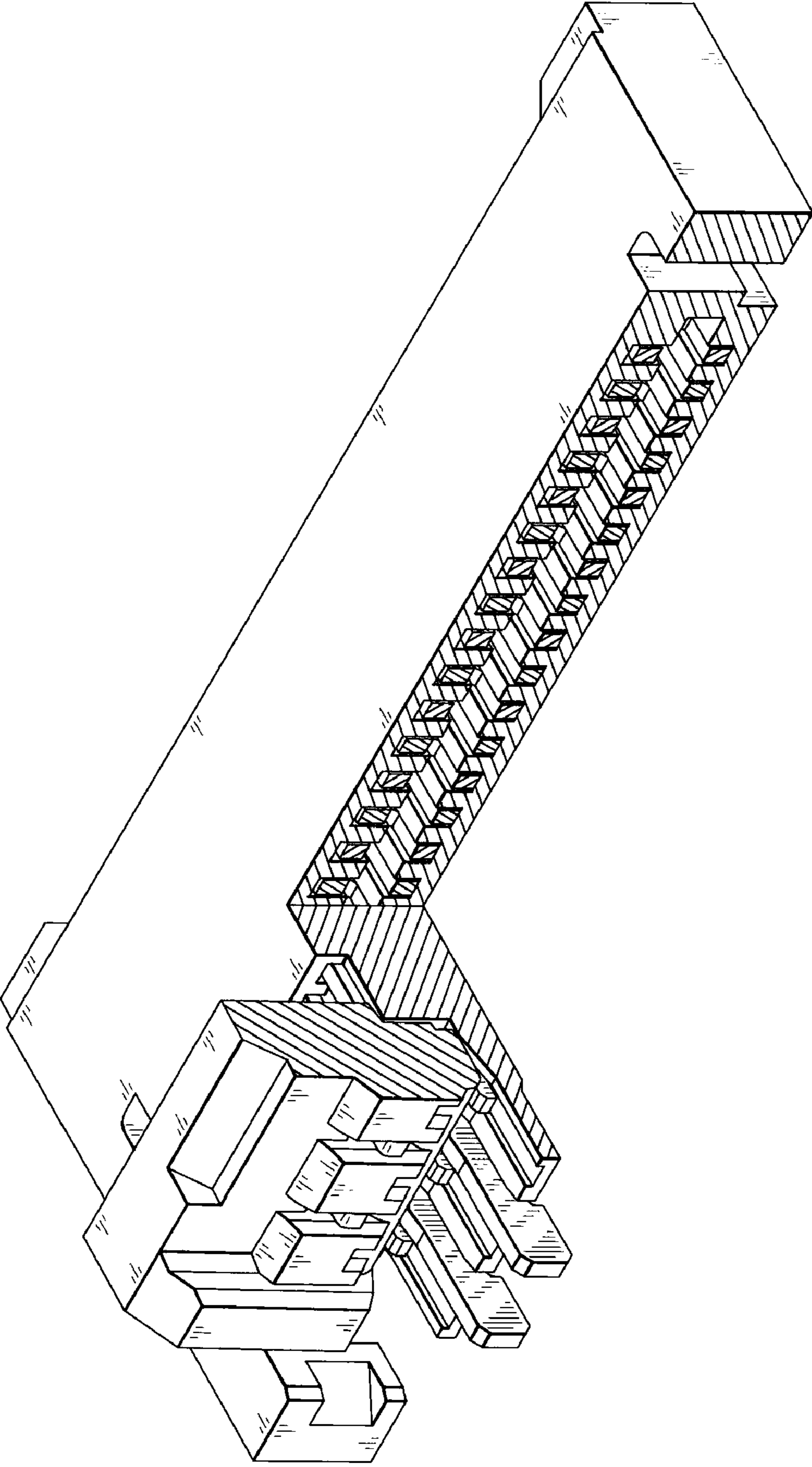

Fig. 26

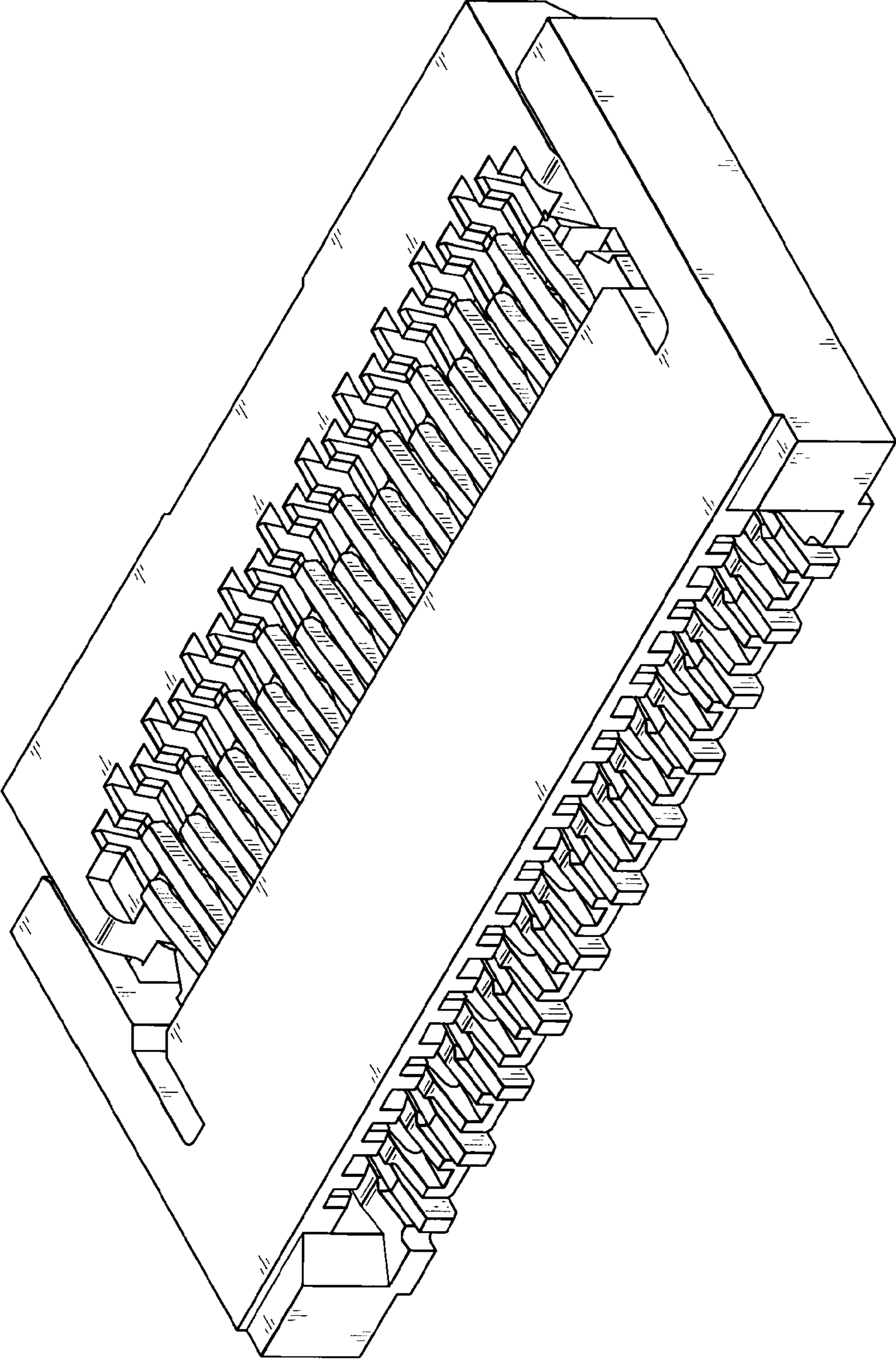

Fig. 27

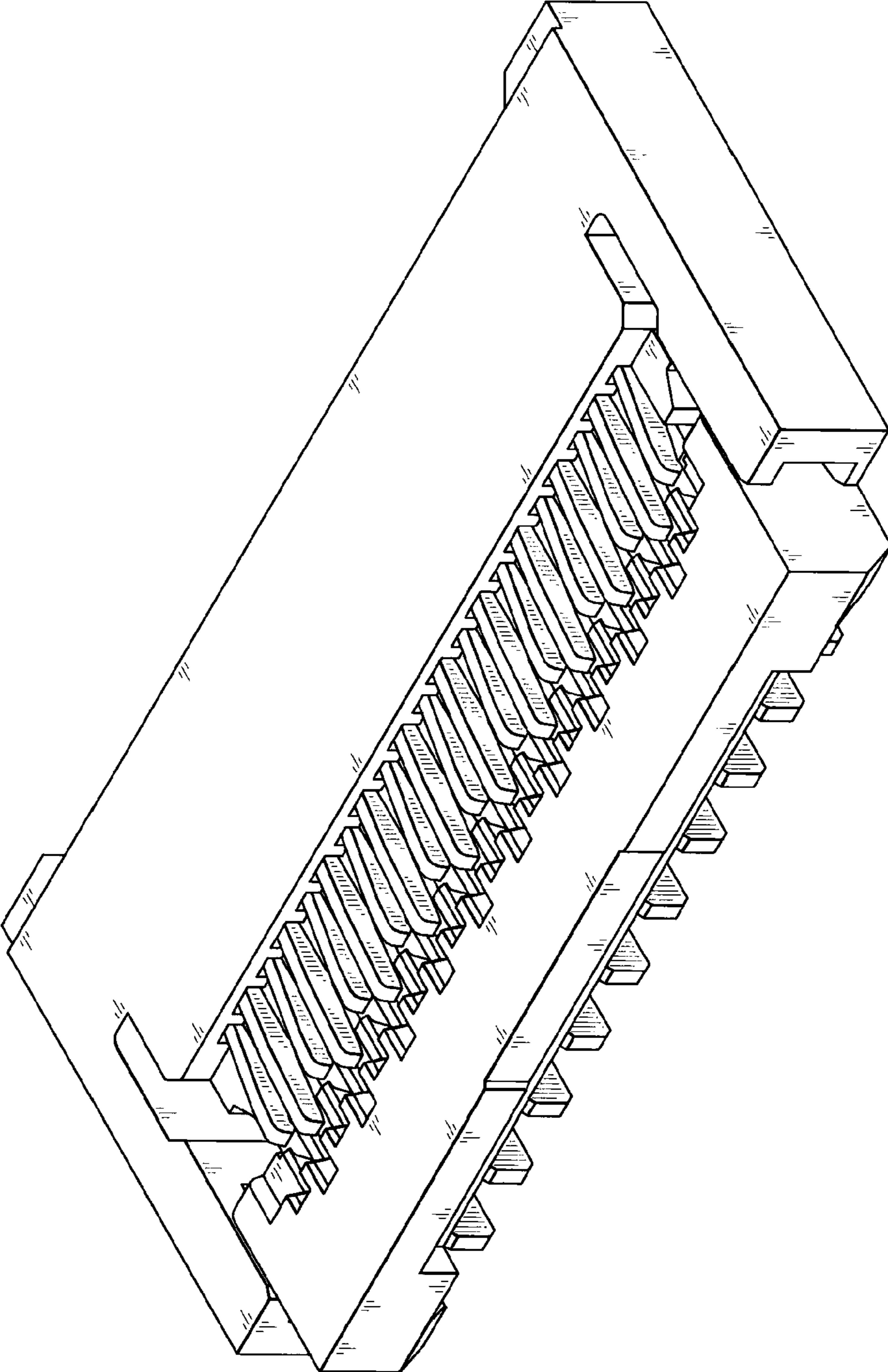

Fig. 28

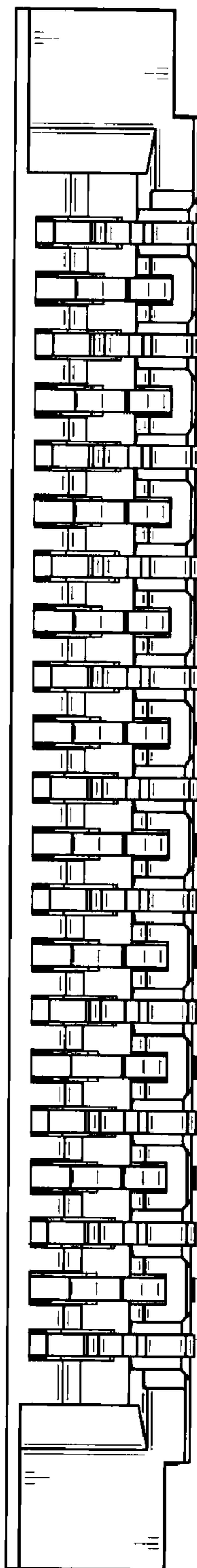

Fig. 29

Fig. 30

