



US00D600199S

(12) **United States Design Patent**
Ibaraki

(10) **Patent No.:** **US D600,199 S**

(45) **Date of Patent:** **** Sep. 15, 2009**

(54) **AUTOMOBILE TIRE**

(75) Inventor: **Daisuke Ibaraki**, Osaka (JP)

(73) Assignee: **Toyo Tire & Rubber Co., Ltd.**, Osaka (JP)

(**) Term: **14 Years**

(21) Appl. No.: **29/306,331**

(22) Filed: **Apr. 7, 2008**

(30) **Foreign Application Priority Data**

Mar. 4, 2008 (JP) 2008-007747

(51) **LOC (9) Cl.** **12-15**

(52) **U.S. Cl.** **D12/605**

(58) **Field of Classification Search** D12/500-501,
D12/544, 579, 600, 601, 605; 152/523-524,
152/DIG. 12, 555; 40/587, 596; D7/588,
D7/396.4-396.5

See application file for complete search history.

(56) **References Cited**

U.S. PATENT DOCUMENTS

D565,504 S * 4/2008 Tanaka D12/605
D569,336 S * 5/2008 Onoe D12/605
D569,791 S * 5/2008 Iwabuchi et al. D12/605
D574,766 S * 8/2008 Iwabuchi et al. D12/605

D576,544 S * 9/2008 Onoe D12/605
D584,682 S * 1/2009 Tanaka D12/605
D590,332 S * 4/2009 Sato D12/605

FOREIGN PATENT DOCUMENTS

JP D1171455 S 4/2003
JP D1255185 S 11/2005

* cited by examiner

Primary Examiner—Stacia Cadmus

(74) *Attorney, Agent, or Firm*—Westerman, Hattori, Daniels & Adrian, LLP.

(57) **CLAIM**

The ornamental design for an automobile tire, as shown and described.

DESCRIPTION

FIG. 1 is a front view of the automobile tire;

FIG. 2 is a rear view of the automobile tire;

FIG. 3 is a reference enlarged partial view of the front view of the automobile tire; and,

FIG. 4 is an enlarged cross-section view taken along the line A1-A2 in the space B in FIG. 3.

In the drawings, the broken lines defining the tire depict environmental subject matter that forms no part of the claimed design.

1 Claim, 4 Drawing Sheets

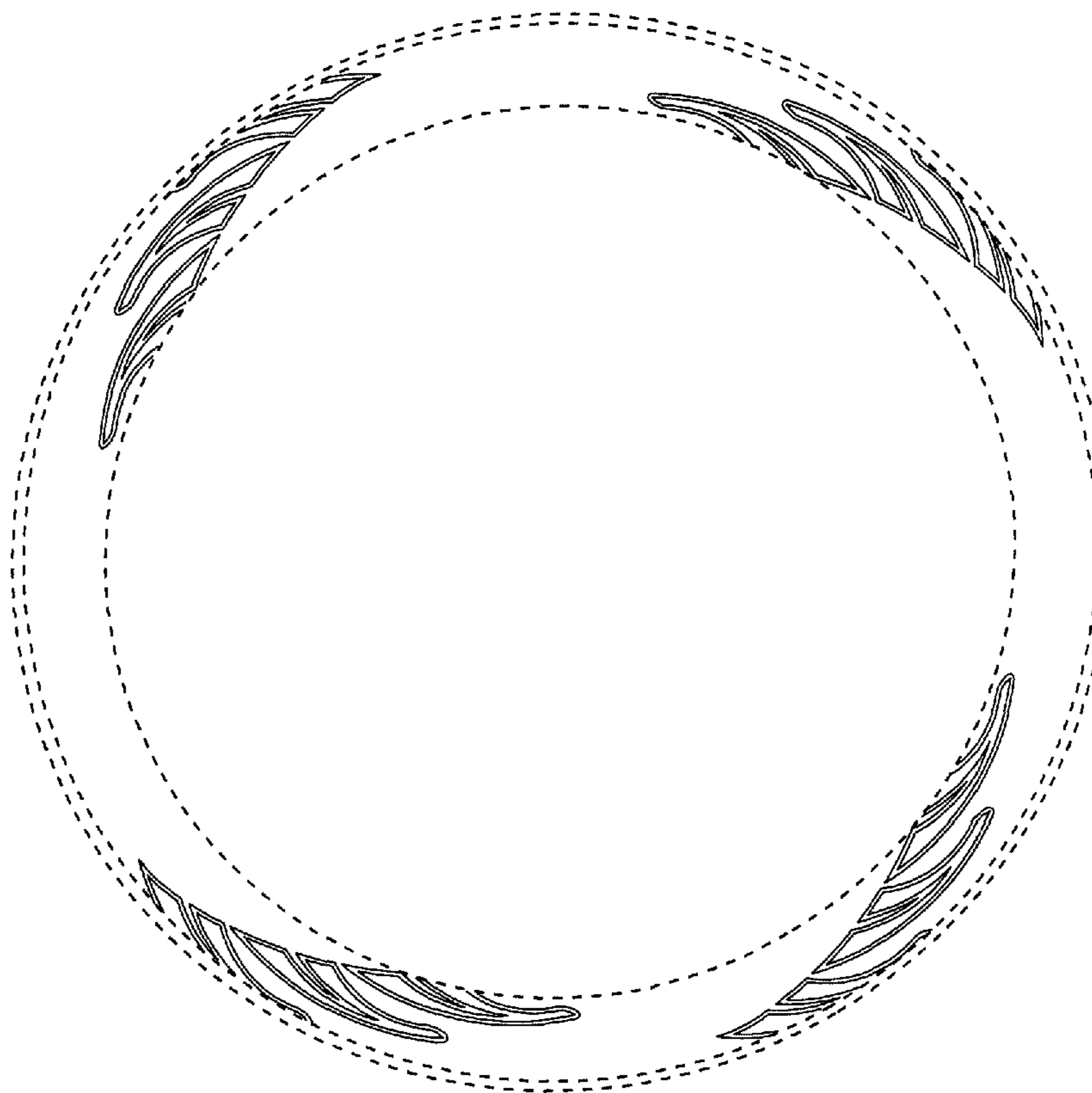

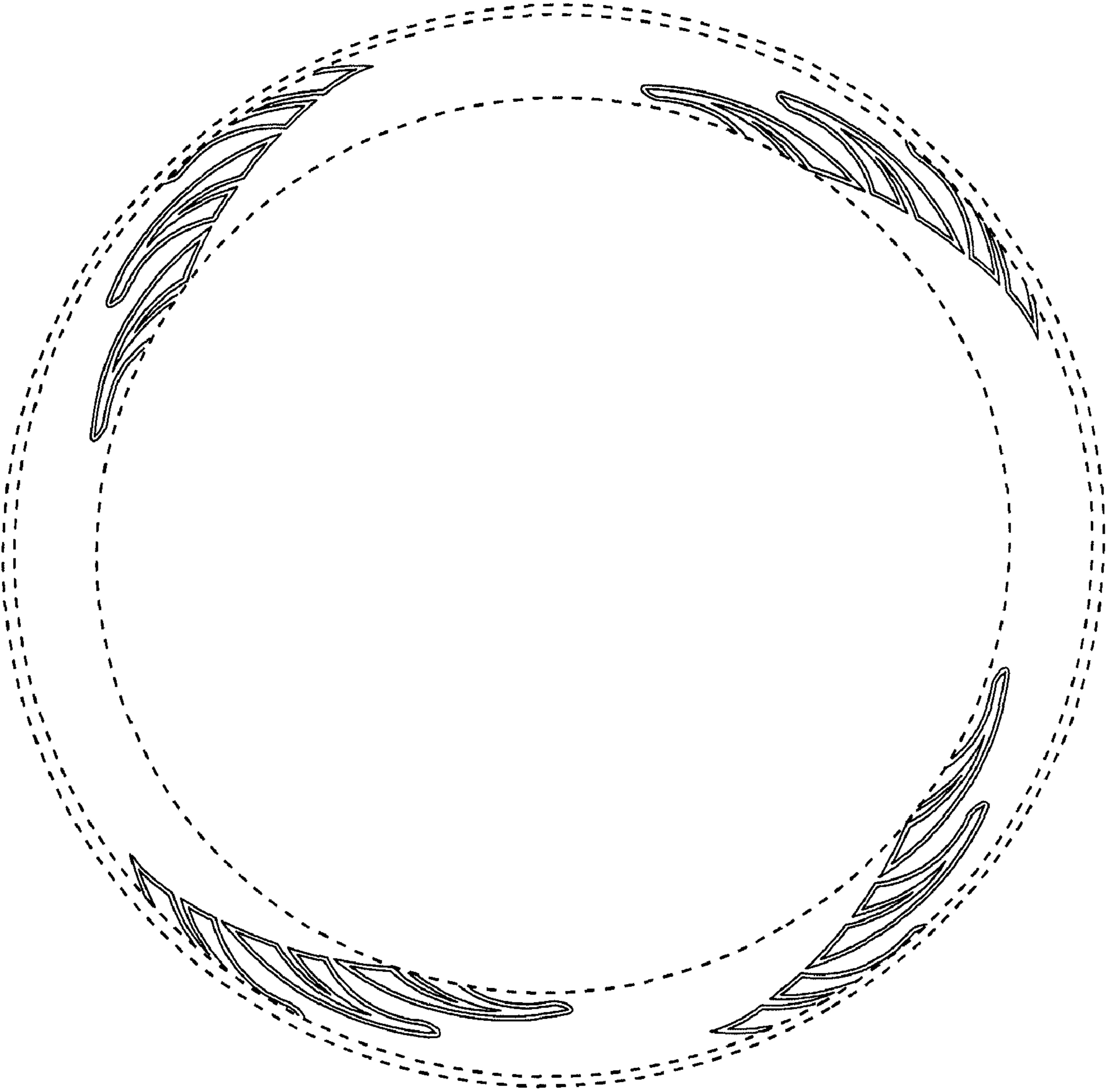

FIG.1

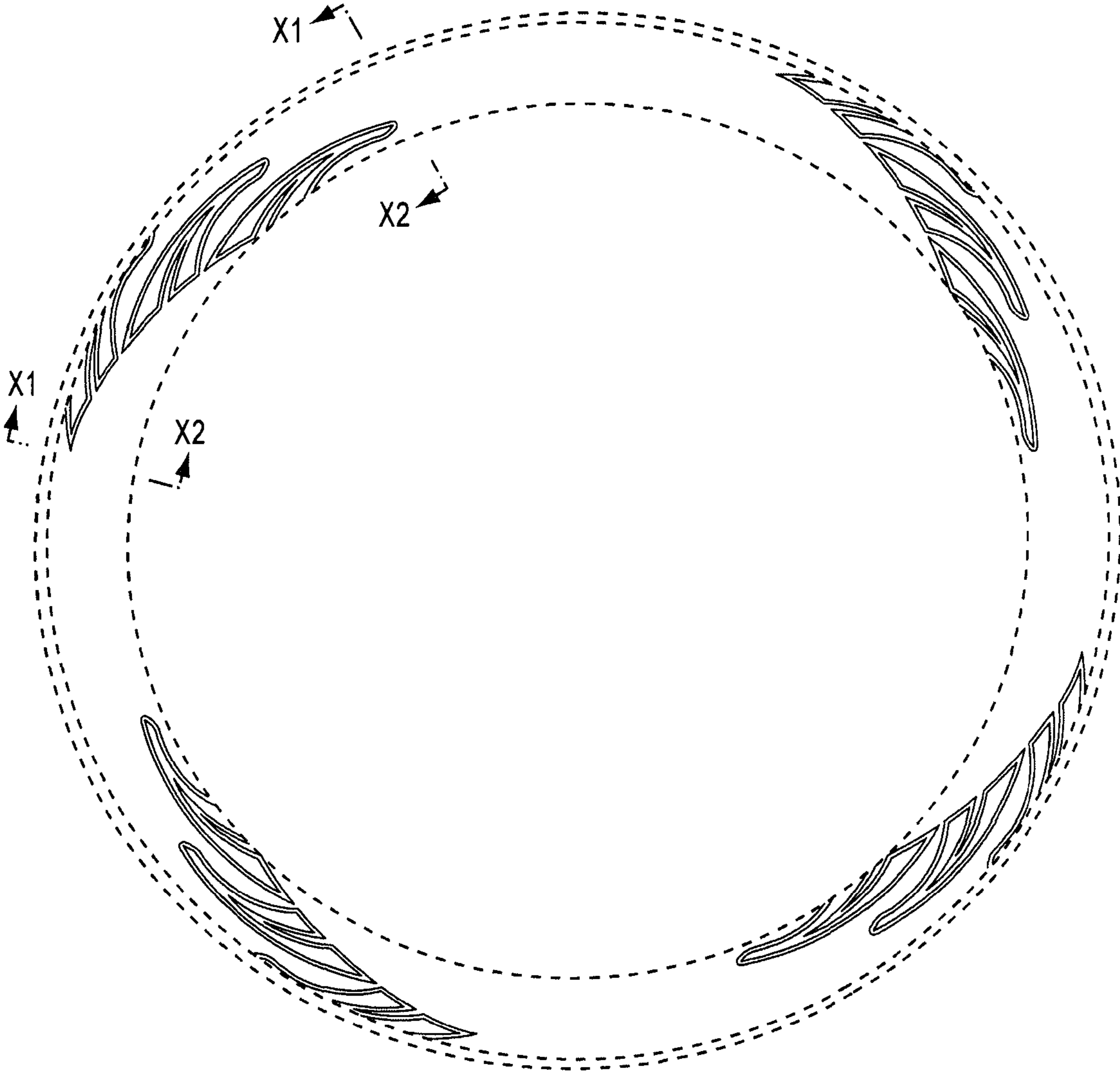

FIG.2

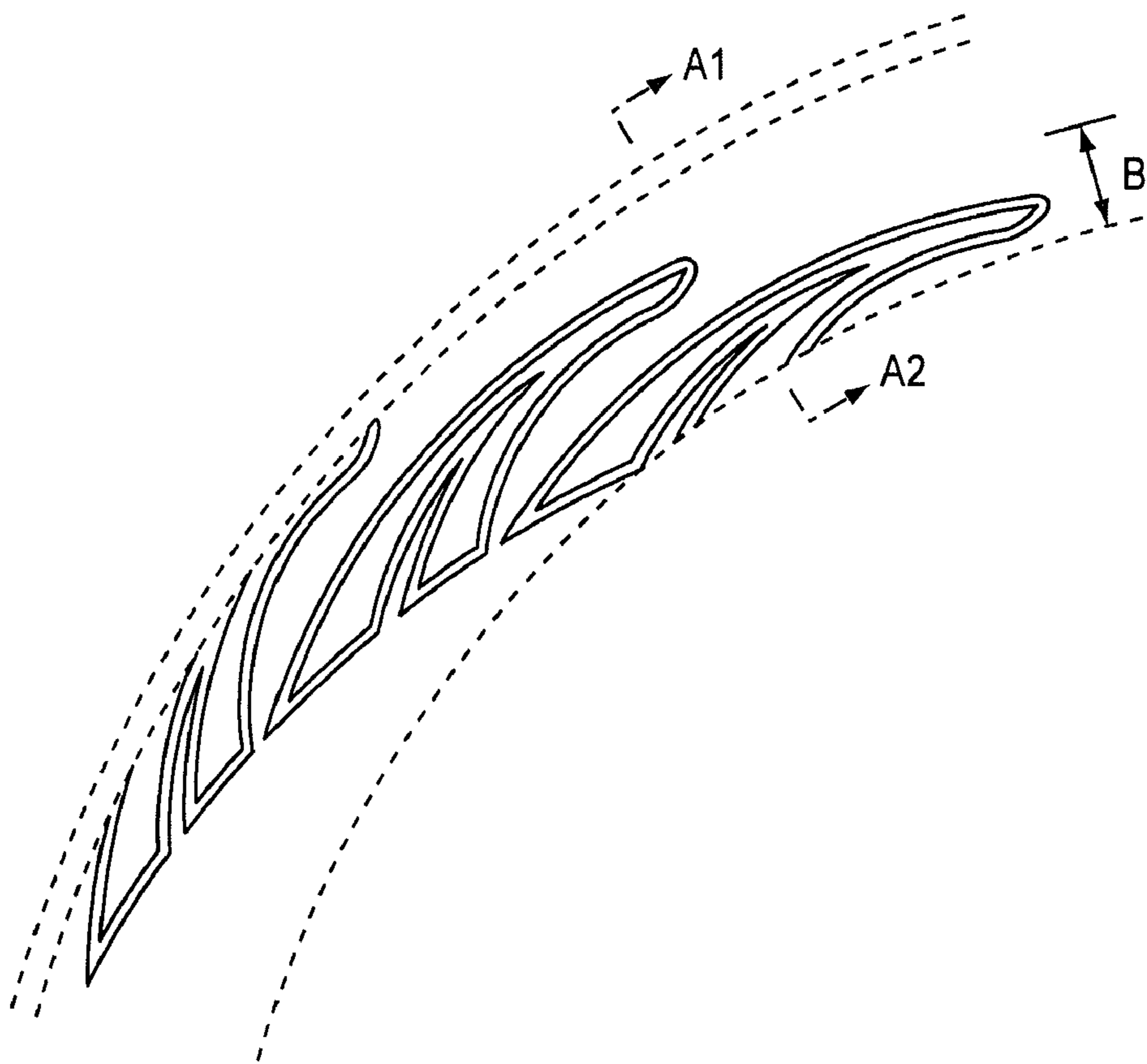

FIG.3

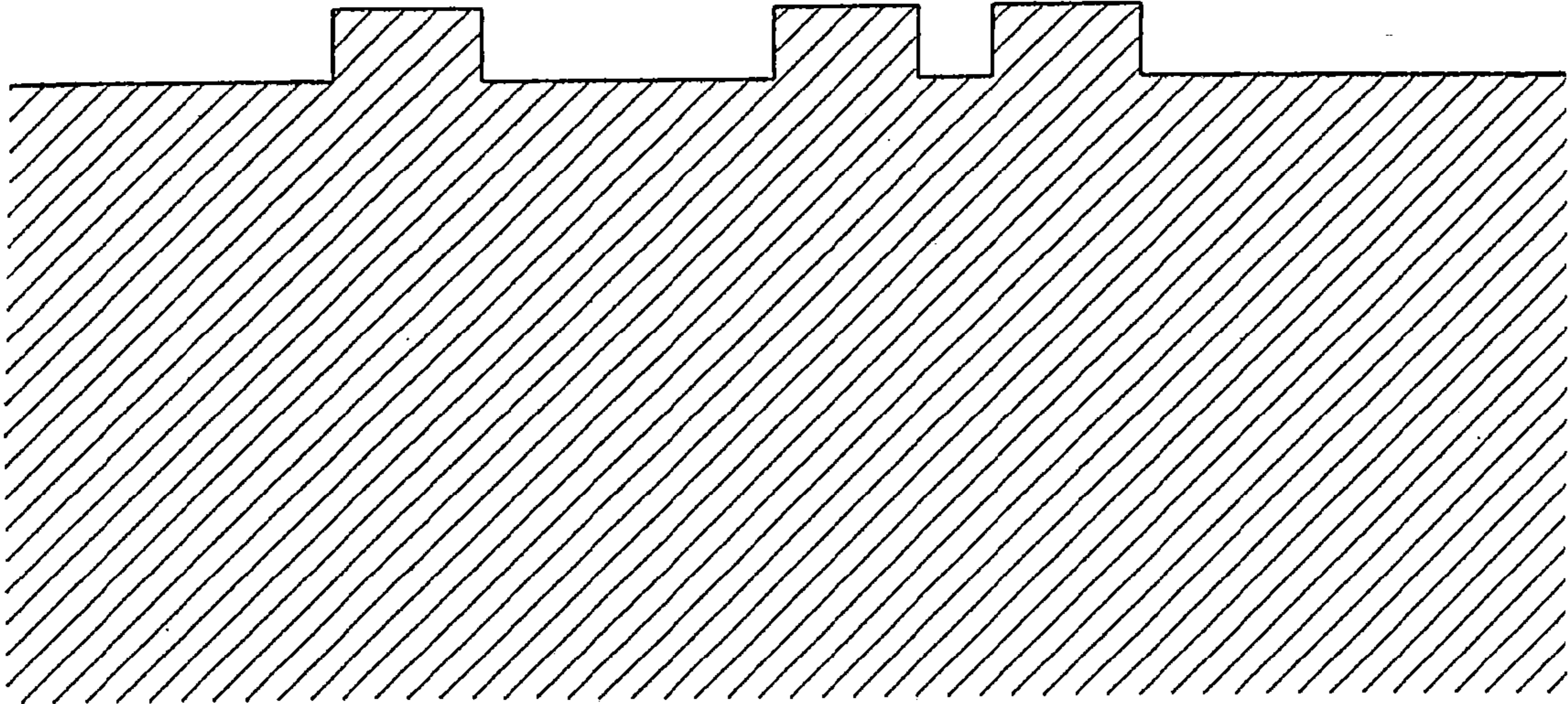

FIG.4