



US00D600172S

(12) **United States Design Patent**  
**Frenzel et al.**

(10) **Patent No.:** **US D600,172 S**  
(45) **Date of Patent:** **\*\* Sep. 15, 2009**

(54) **FRONT PORTION OF A VEHICLE, TOY,  
AND/OR OTHER REPLICAS**

(75) Inventors: **Klaus Frenzel**, Winnenden (DE);  
**Thomas Stopka**, Lichtenstein (DE);  
**Gorden Wagener**, Stuttgart (DE)

(73) Assignee: **Daimler AG**, Stuttgart (DE)

(\*\*) Term: **14 Years**

(21) Appl. No.: **29/311,193**

(22) Filed: **Jan. 13, 2009**

(30) **Foreign Application Priority Data**

Jul. 14, 2008 (EM) ..... 000969019-0002

(51) **LOC (9) Cl.** ..... **12-16**

(52) **U.S. Cl.** ..... **D12/164**

(58) **Field of Classification Search** ..... D12/164,  
D12/196, 90-92, 86; 296/181.1, 181.5  
See application file for complete search history.

(56) **References Cited**

**U.S. PATENT DOCUMENTS**

- D575,676 S \* 8/2008 Pfeiffer ..... D12/91
- D587,637 S \* 3/2009 Pfeiffer ..... D12/164
- D588,499 S \* 3/2009 Pfeiffer ..... D12/92
- D595,622 S \* 7/2009 Pfeiffer et al. .... D12/164

D596,078 S \* 7/2009 Pfeiffer et al. .... D12/92

\* cited by examiner

*Primary Examiner*—Melody N Brown

(74) *Attorney, Agent, or Firm*—Crowell & Moring LLP

(57) **CLAIM**

The ornamental design for a front portion of a vehicle, toy,  
and/or other replicas, as shown and described.

**DESCRIPTION**

This application is related to the following co-pending appli-  
cations:

U.S. application Ser. No. 29/287,946, filed Oct. 3, 2007;

U.S. application Ser. No. 29/311,226, filed Jan. 23, 2009; and

U.S. application Ser. No. 29/311,192, filed Jan. 13, 2009.

FIG. 1 is a left, front perspective view of a front portion of a  
vehicle, toy, and/or other replicas according to our novel  
design, the right, front perspective view being mirror sym-  
metrical;

FIG. 2 is a front view thereof;

FIG. 3 is a left side view thereof, the right side view being  
mirror symmetrical; and,

FIG. 4 is a top view thereof.

The broken lines are for illustrative purposes only and form  
no part of the claimed design.

**1 Claim, 3 Drawing Sheets**

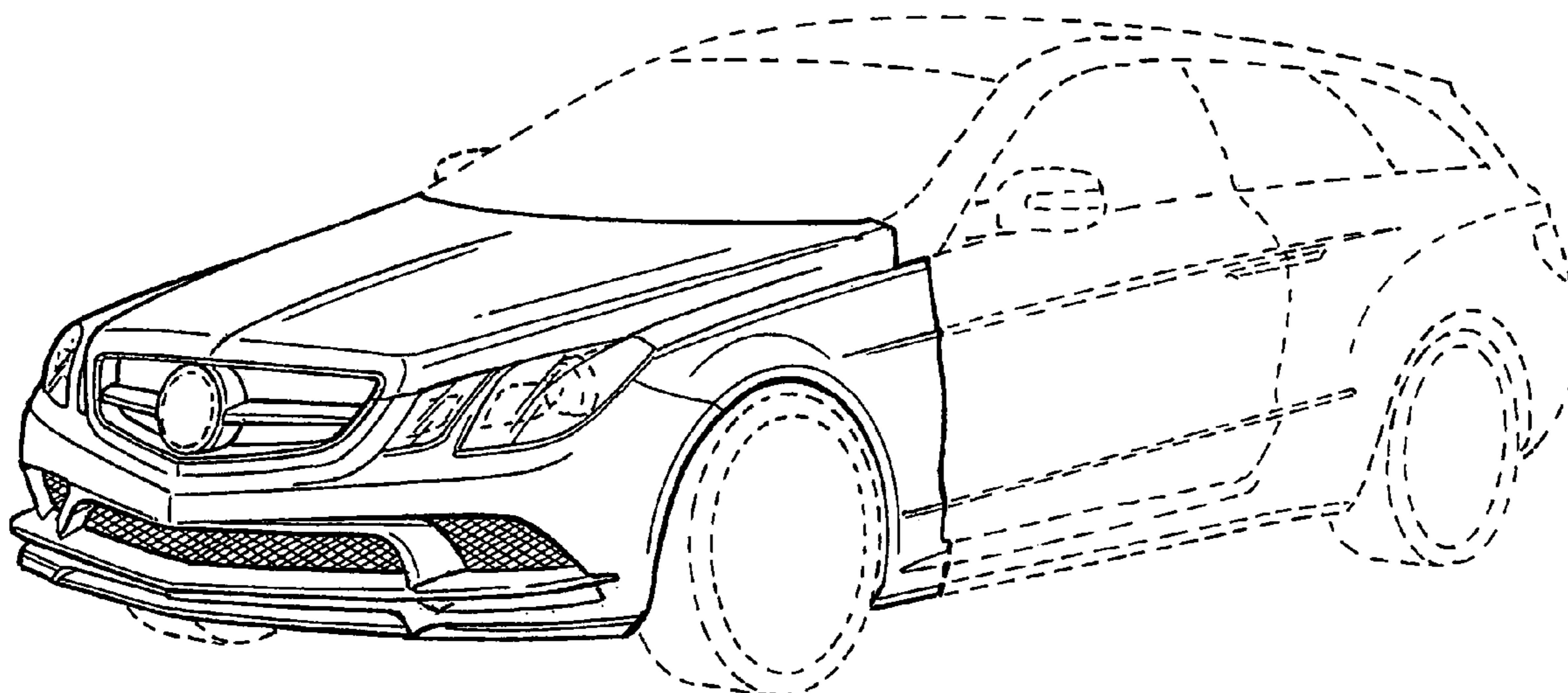

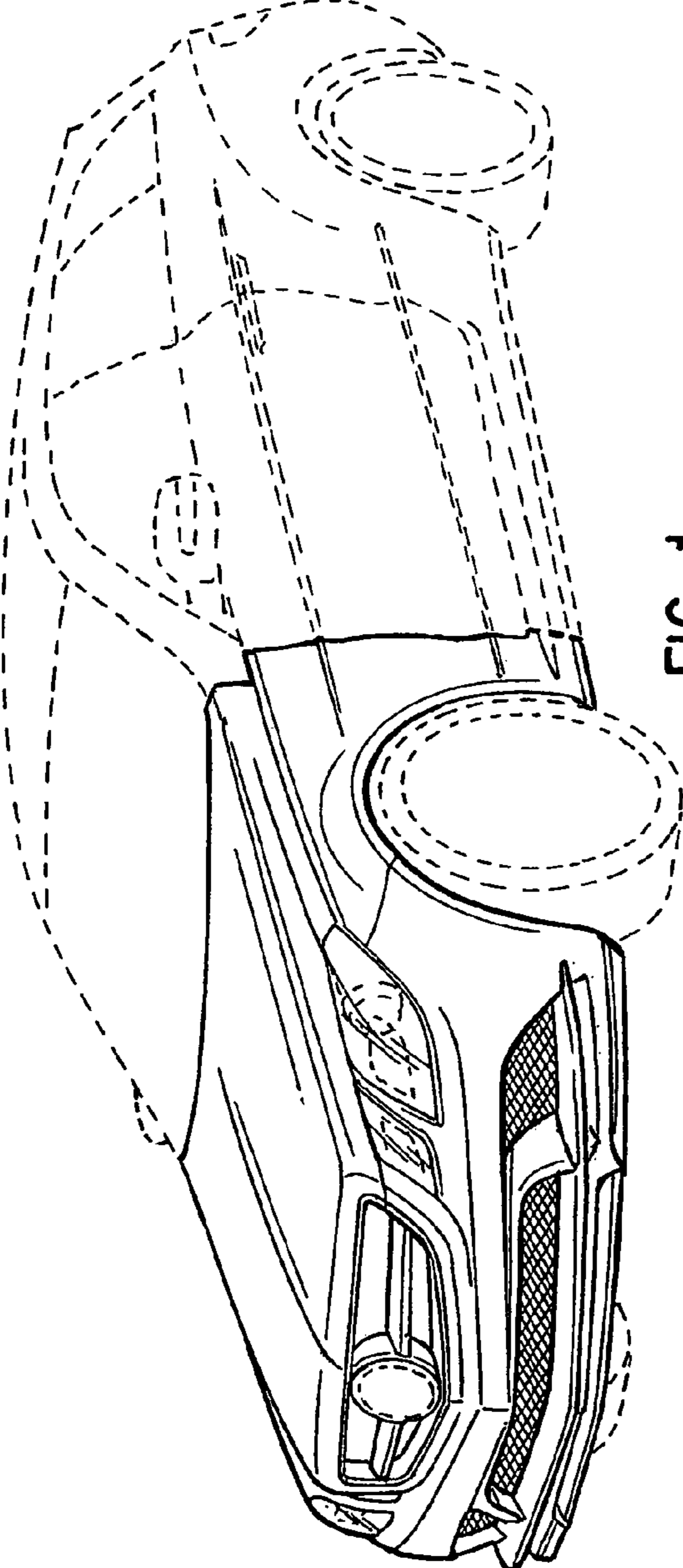

FIG. 1

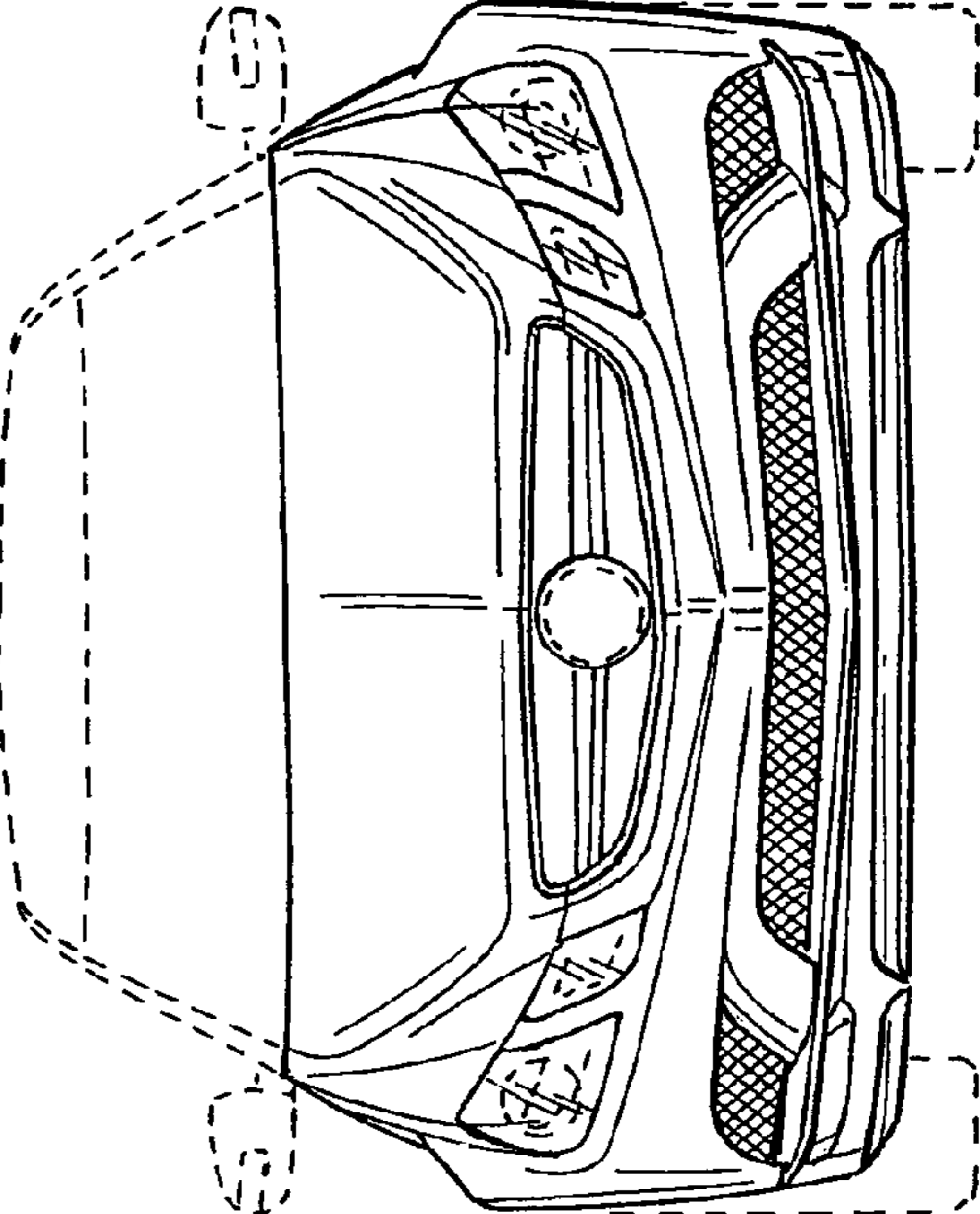

FIG. 2

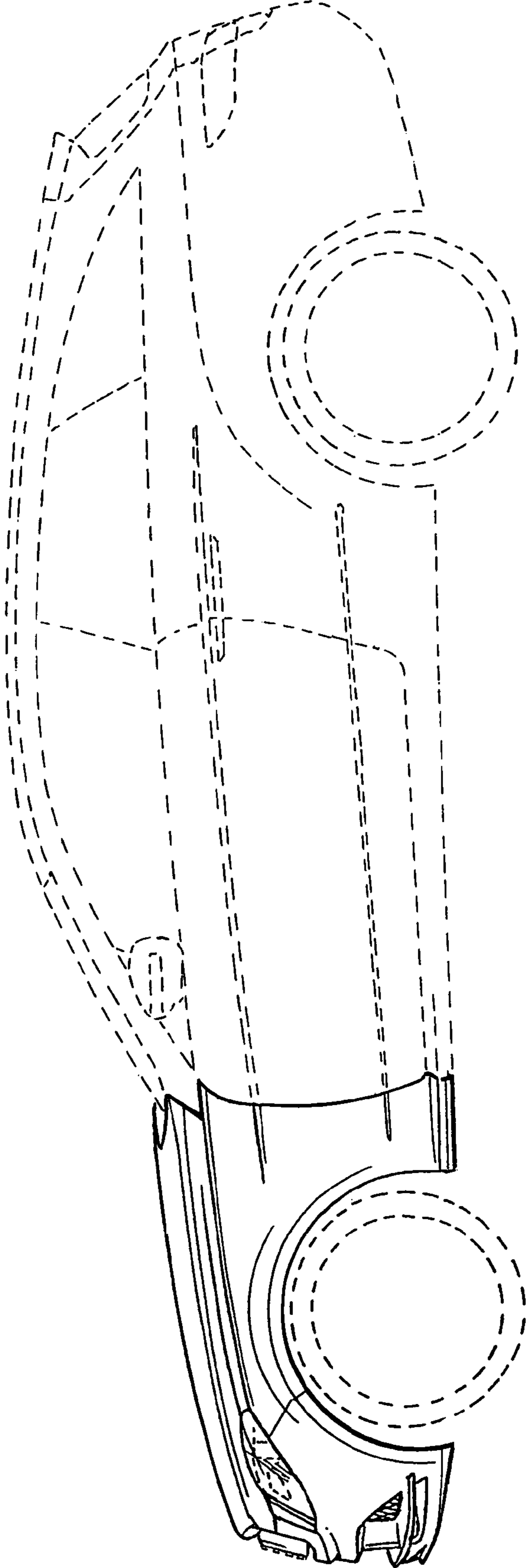

FIG. 3

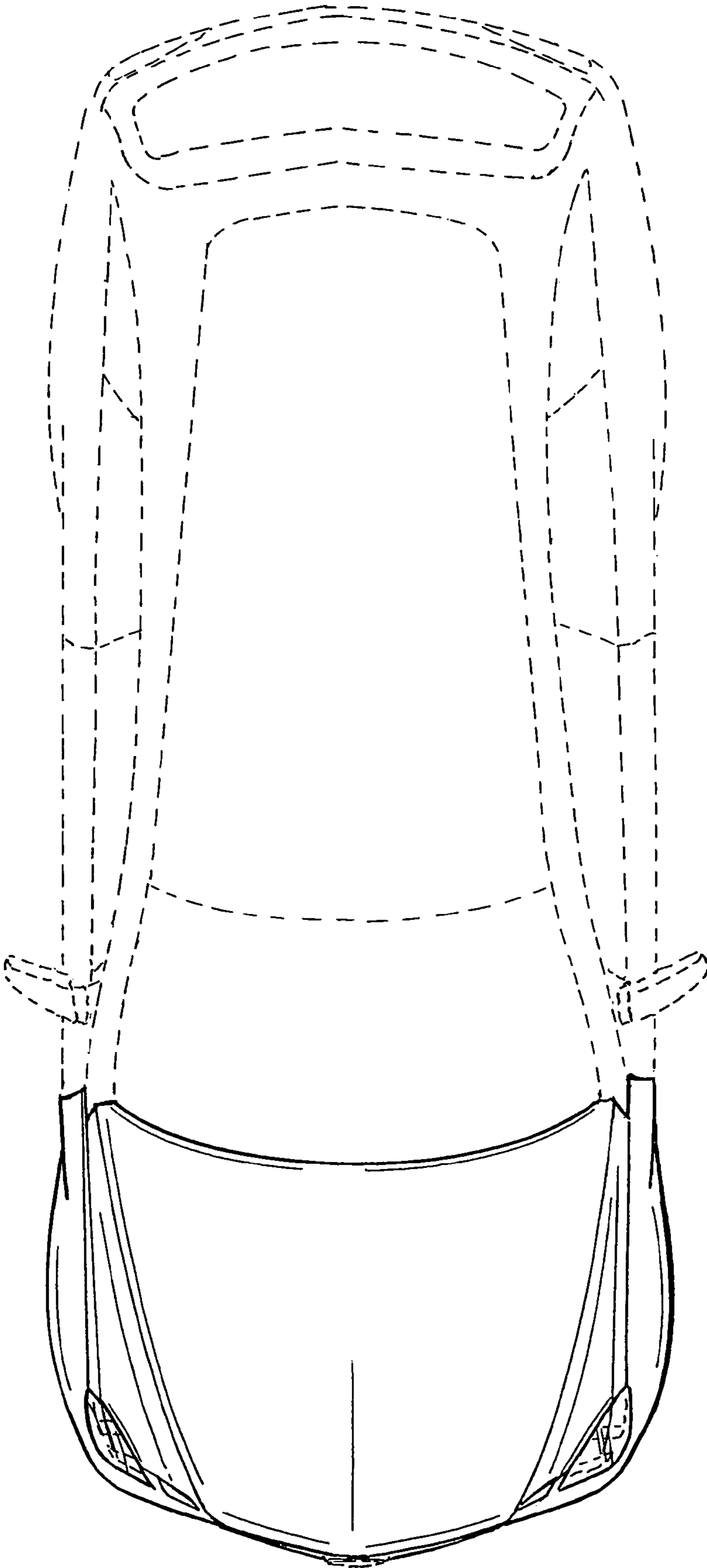

FIG. 4