

US00D600162S

(12) **United States Design Patent**  
**Lin**

(10) **Patent No.:** **US D600,162 S**

(45) **Date of Patent:** **\*\* Sep. 15, 2009**

(54) **MOTORCYCLE**

D534,838 S \* 1/2007 Kato et al. .... D12/110  
D576,921 S \* 9/2008 Tong ..... D12/110

(76) Inventor: **Hua-Zh Lin**, P.O. Box 166-13, Taipei  
(TW) 115

\* cited by examiner

*Primary Examiner*—Robin V Webster

*Assistant Examiner*—Linda Brooks

(\*\*) Term: **14 Years**

(21) Appl. No.: **29/309,782**

(57) **CLAIM**

(22) Filed: **Oct. 10, 2008**

The ornamental design for a motorcycle, as shown.

(51) **LOC (9) Cl.** ..... **12-11**

**DESCRIPTION**

(52) **U.S. Cl.** ..... **D12/110**

FIG. 1 is a front elevational view of a motorcycle showing my new design;

(58) **Field of Classification Search** ..... D12/110;  
180/219, 220

FIG. 2 is a rear elevational view thereof;

See application file for complete search history.

FIG. 3 is a left side elevational view thereof;

FIG. 4 is a right side elevational view thereof;

(56) **References Cited**

**U.S. PATENT DOCUMENTS**

D488,102 S \* 4/2004 Shimokawa et al. .... D12/110

D493,122 S \* 7/2004 Huang et al. .... D12/110

D519,061 S \* 4/2006 Matsuno et al. .... D12/110

FIG. 5 is a top plan view thereof; and,

FIG. 6 is a perspective view thereof.

**1 Claim, 3 Drawing Sheets**

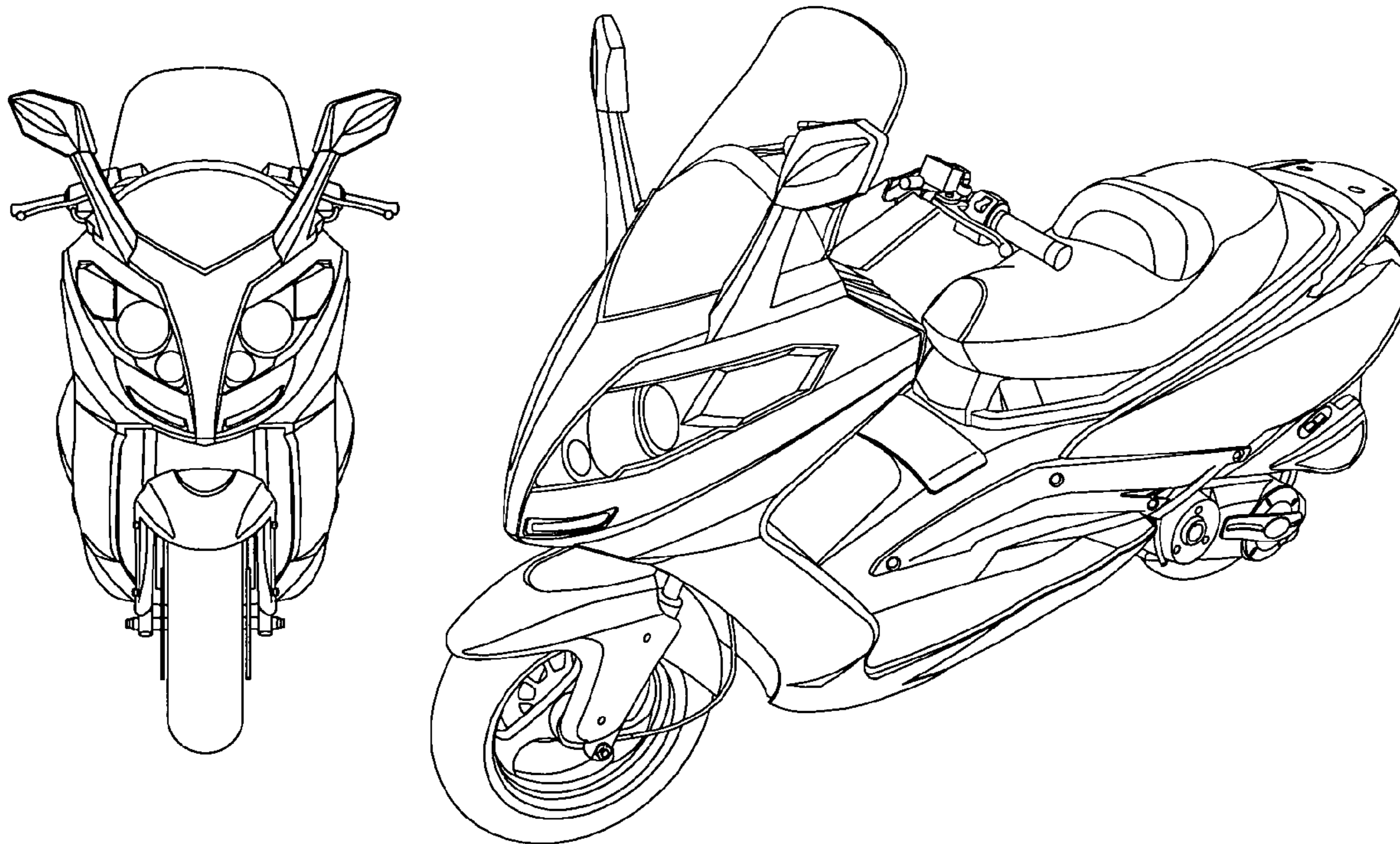

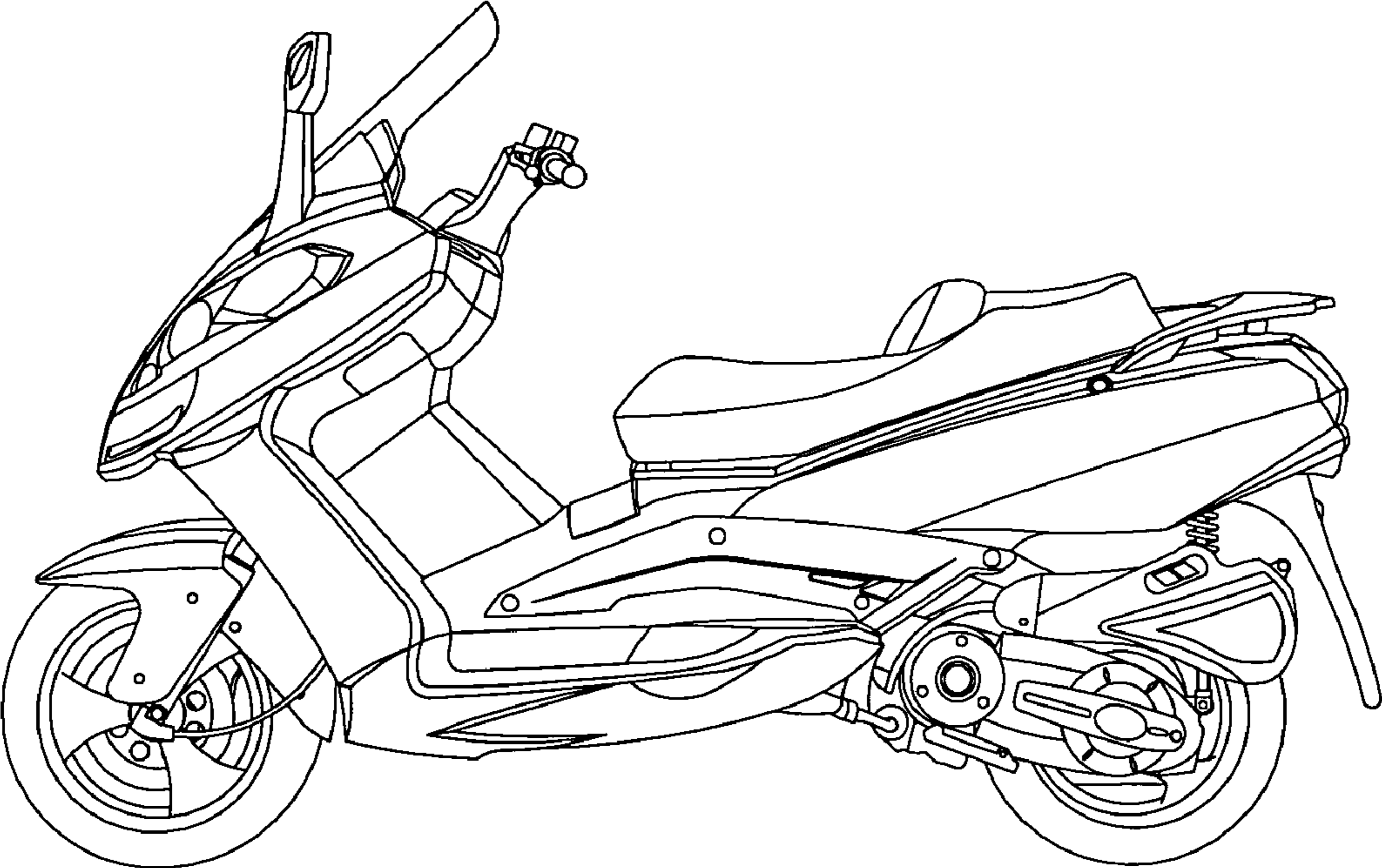

Fig.1

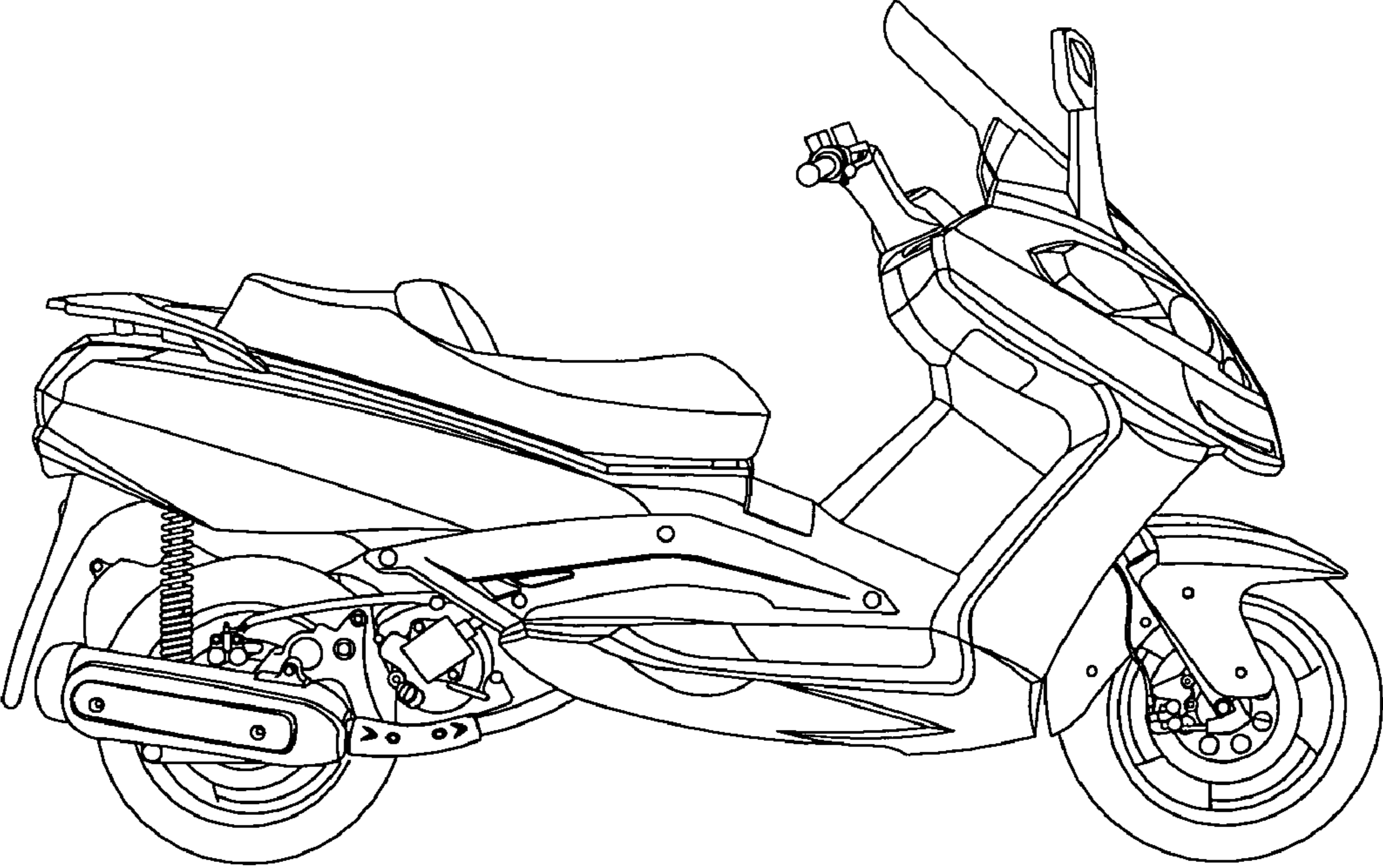

Fig.2

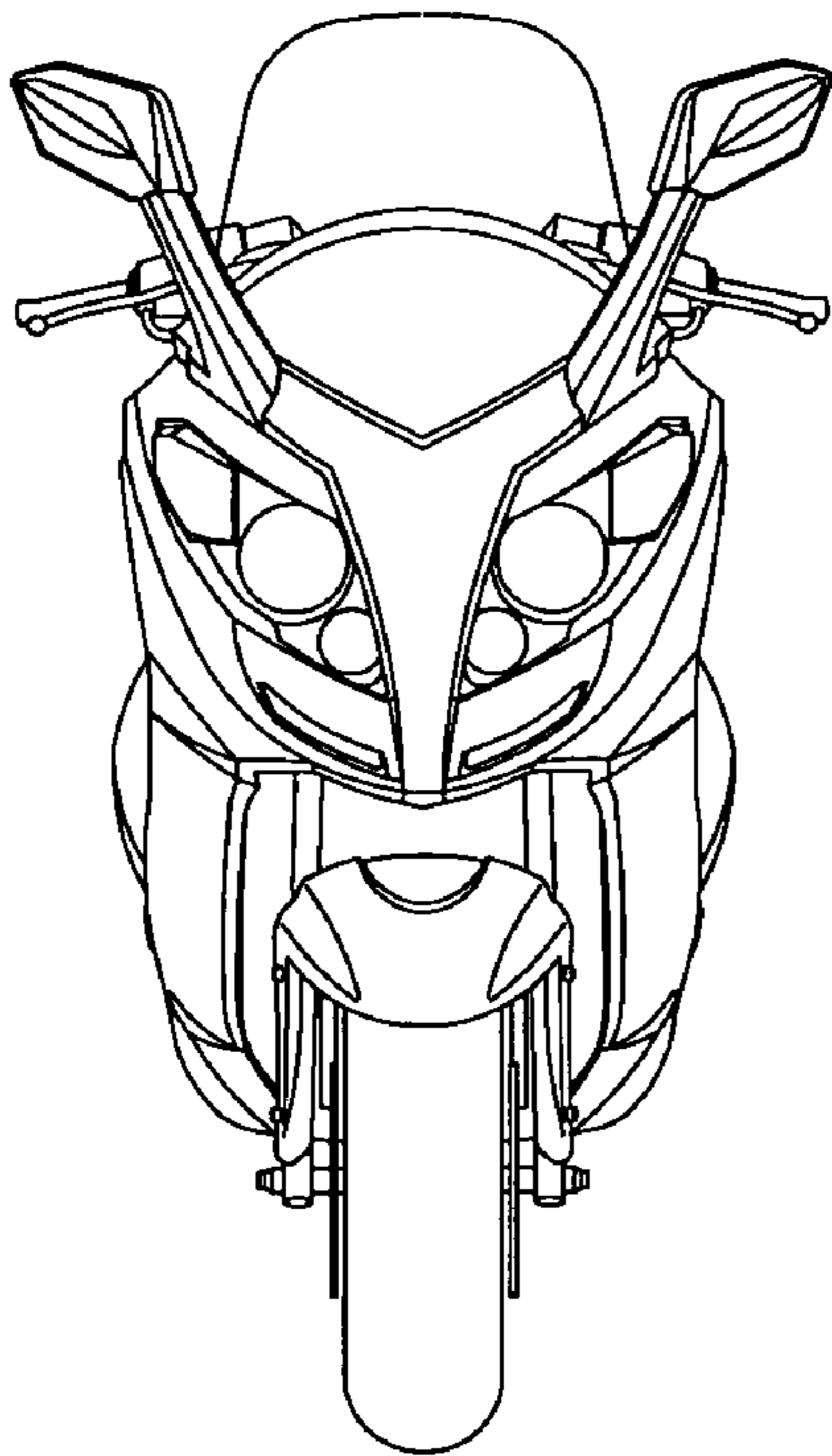

Fig.3

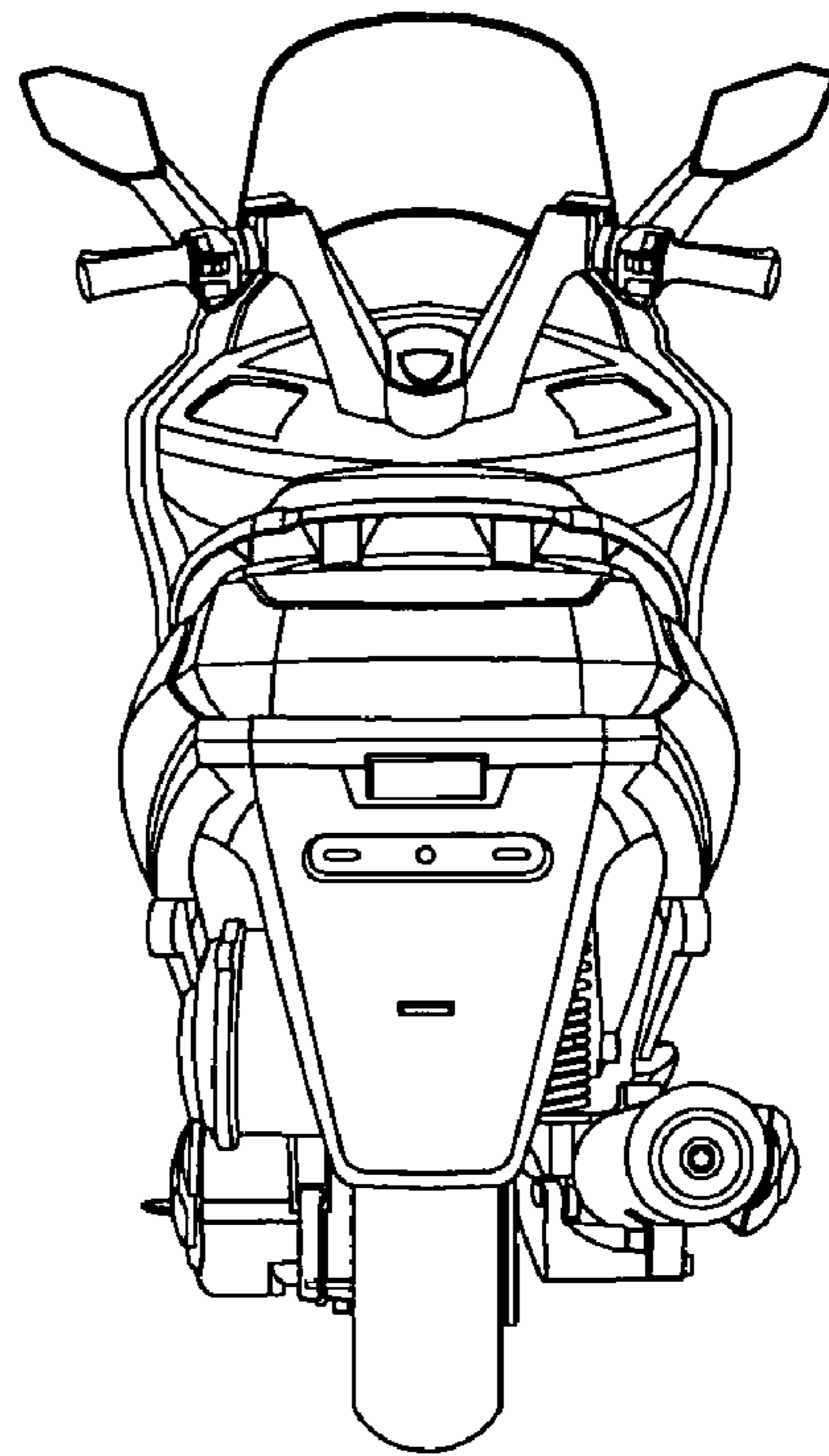

Fig.4

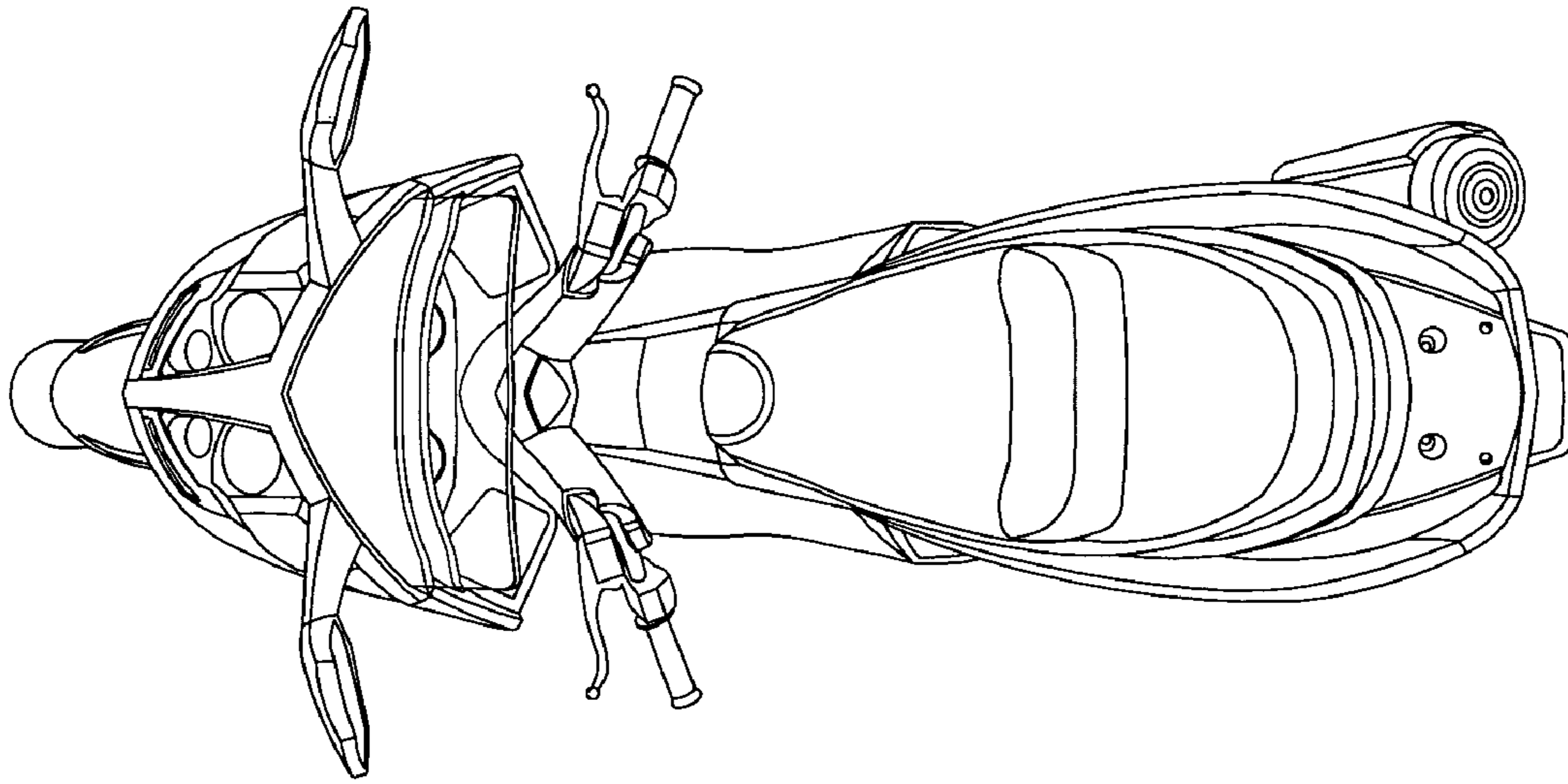

Fig.5

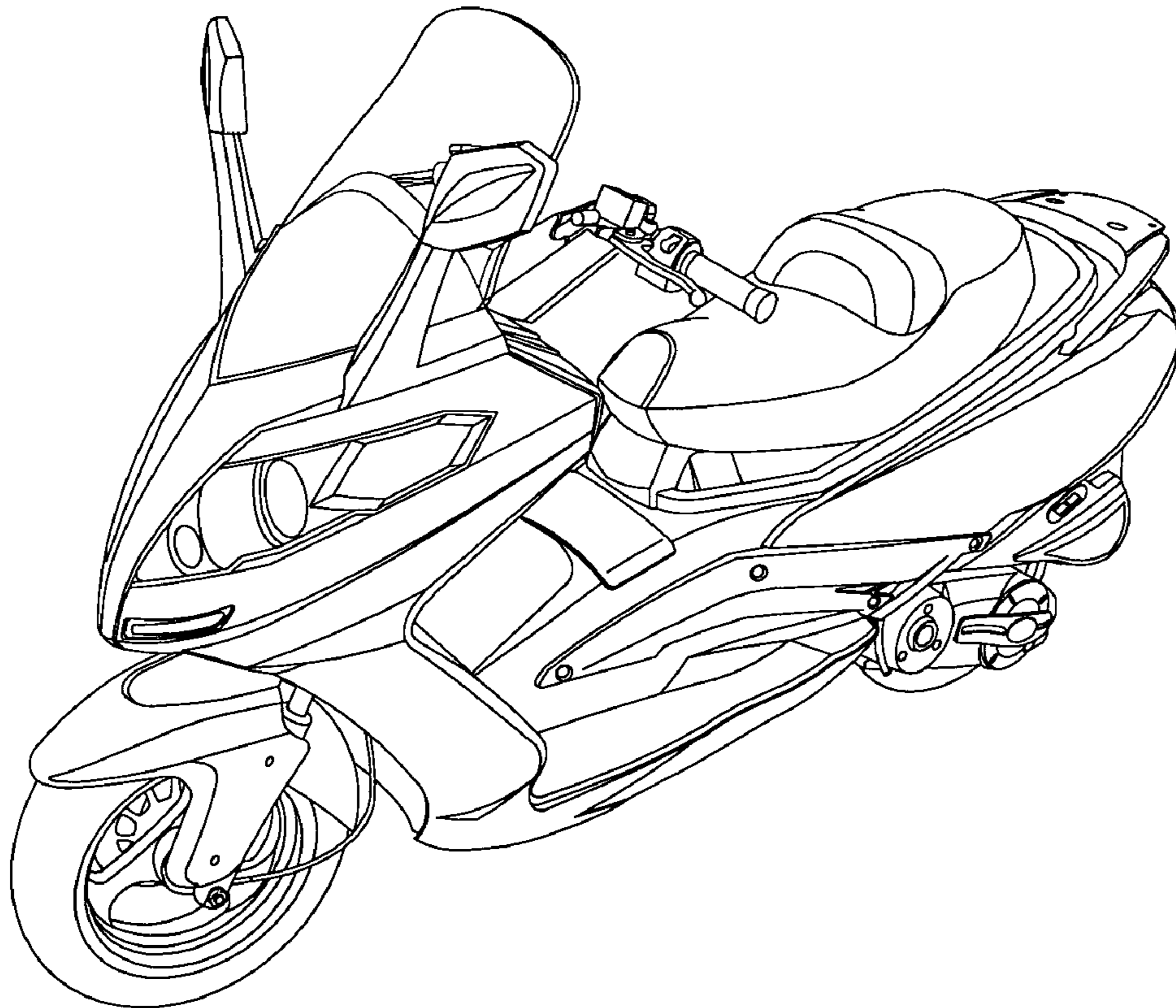

Fig.6