



US00D599899S

(12) **United States Design Patent**  
**Thompson**

(10) **Patent No.:** **US D599,899 S**

(45) **Date of Patent:** **\*\* Sep. 8, 2009**

(54) **PLUG IN WARMER ASSEMBLY FOR WAXES AND OILS**

D206,463 S \* 12/1966 Federighi ..... D9/502  
D322,558 S \* 12/1991 Halm et al. .... D32/29.1  
D530,221 S \* 10/2006 Paglina ..... D9/692

(75) Inventor: **Richard Orville Thompson**, Eagle, ID (US)

\* cited by examiner

*Primary Examiner*—Sandra Snapp

(73) Assignee: **Scentsy, Inc.**, Meridian, ID (US)

(74) *Attorney, Agent, or Firm*—Perkins Coie LLP

(\*\*) Term: **14 Years**

(57) **CLAIM**

(21) Appl. No.: **29/326,998**

The ornamental designs for the plug in warmer assembly for waxes and oils, as shown and described.

(22) Filed: **Oct. 28, 2008**

**DESCRIPTION**

(51) **LOC (9) Cl.** ..... **28-99**

FIG. 1 is an isometric view of a plug in warmer assembly for waxes and oils showing my new design;

(52) **U.S. Cl.** ..... **D23/366**

FIG. 2 is a left side view thereof, the right side view being a mirror image of the left side view;

(58) **Field of Classification Search** ..... D23/355-369;  
261/DIG. 17, DIG. 42, DIG. 65, DIG. 88,  
261/DIG. 89; 239/34-37, 44, 45, 53, 54,  
239/57, 60, 136, 152, 302, 326; 392/386,  
392/390, 392, 394, 395; D28/5, 6

FIG. 3 is a front side view thereof;

See application file for complete search history.

FIG. 4 is a back side view thereof;

FIG. 5 is a top plan view thereof; and,

(56) **References Cited**

FIG. 6 is a bottom plan view thereof.

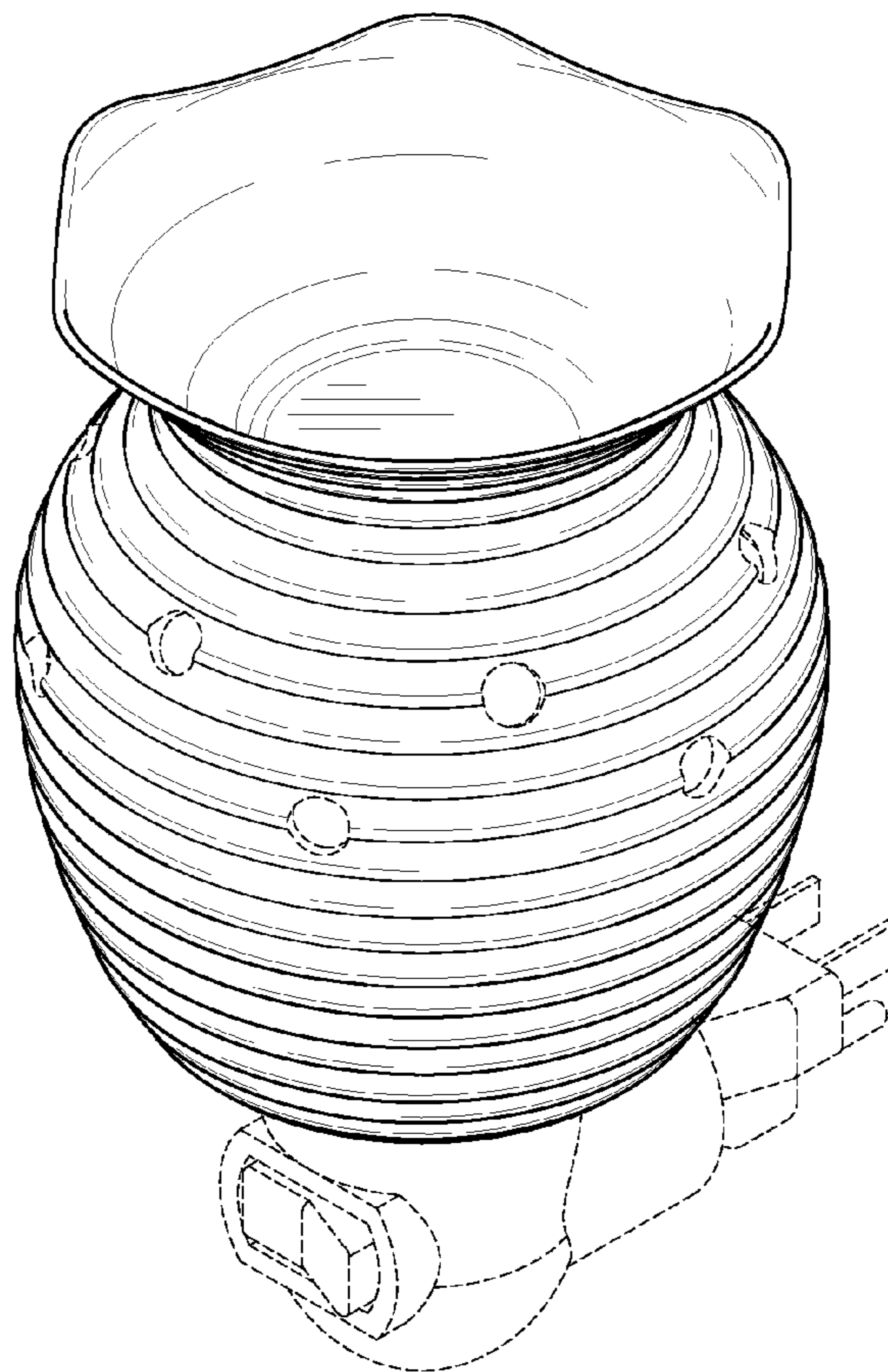
**U.S. PATENT DOCUMENTS**

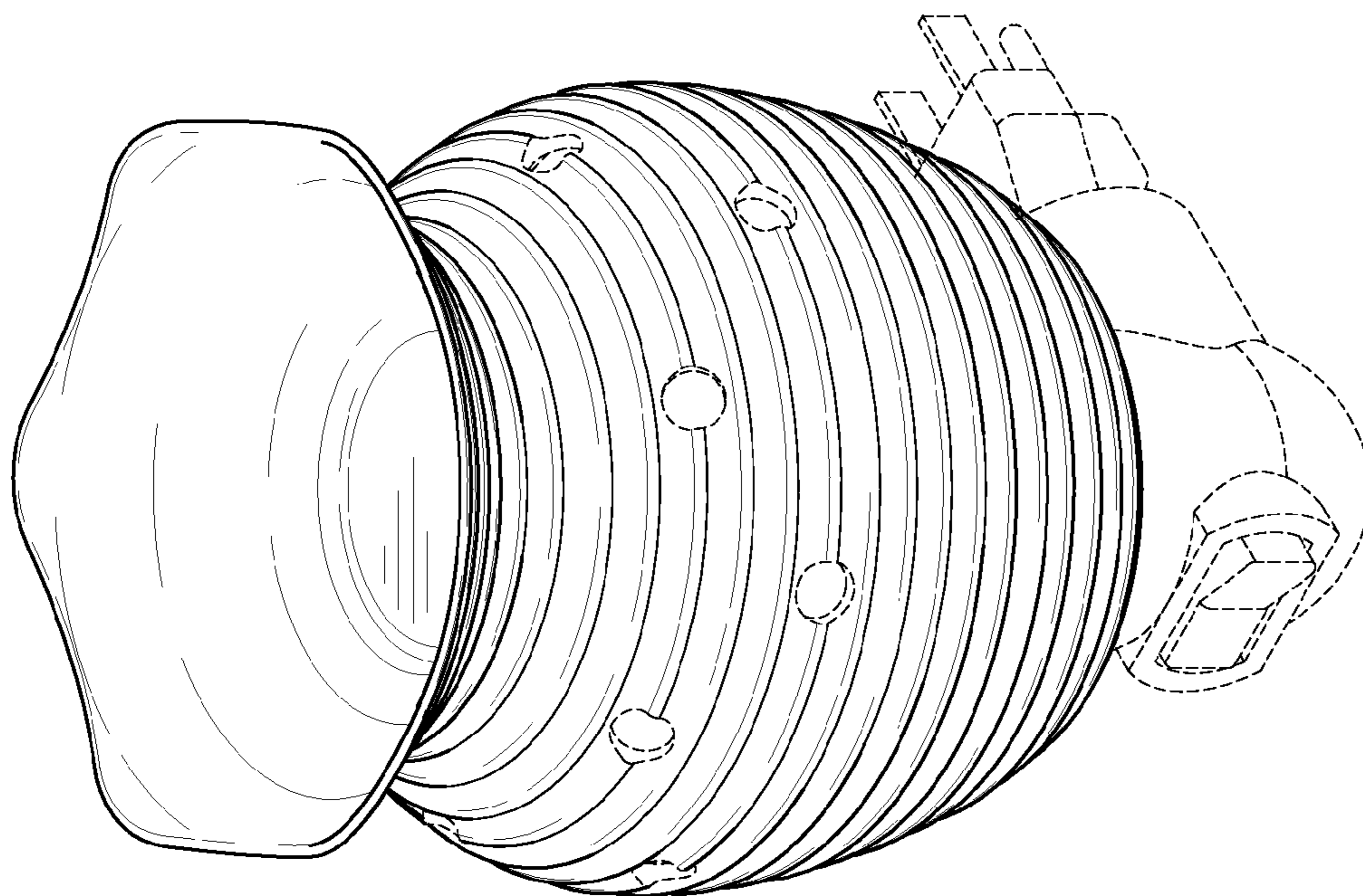
Any broken lines, color patterns, and/or colors are for illustrative purposes only and form no part of the claimed design.

D100,298 S \* 7/1936 Weil ..... D9/502

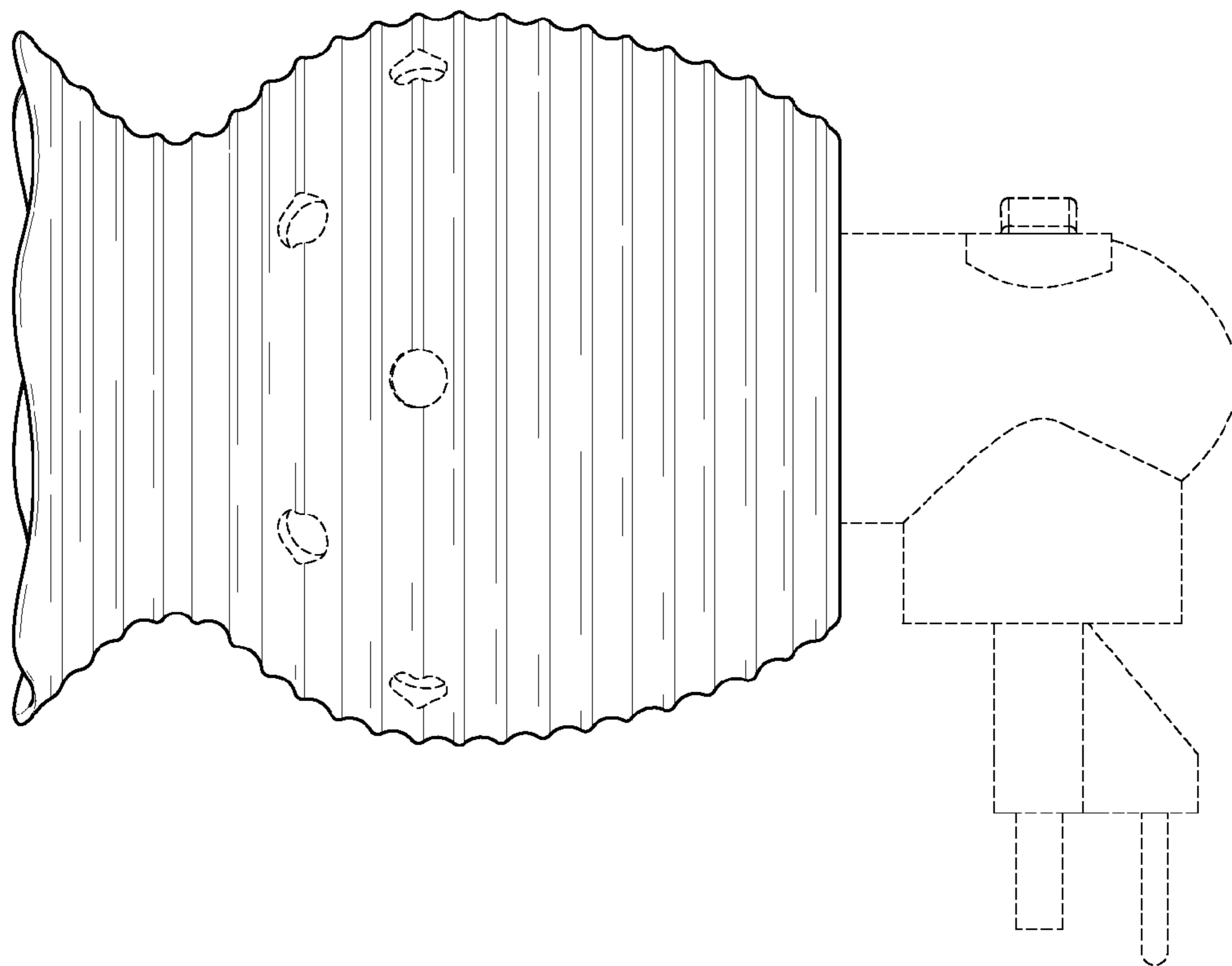
3,167,079 A \* 1/1965 Weil ..... 134/137

**1 Claim, 3 Drawing Sheets**

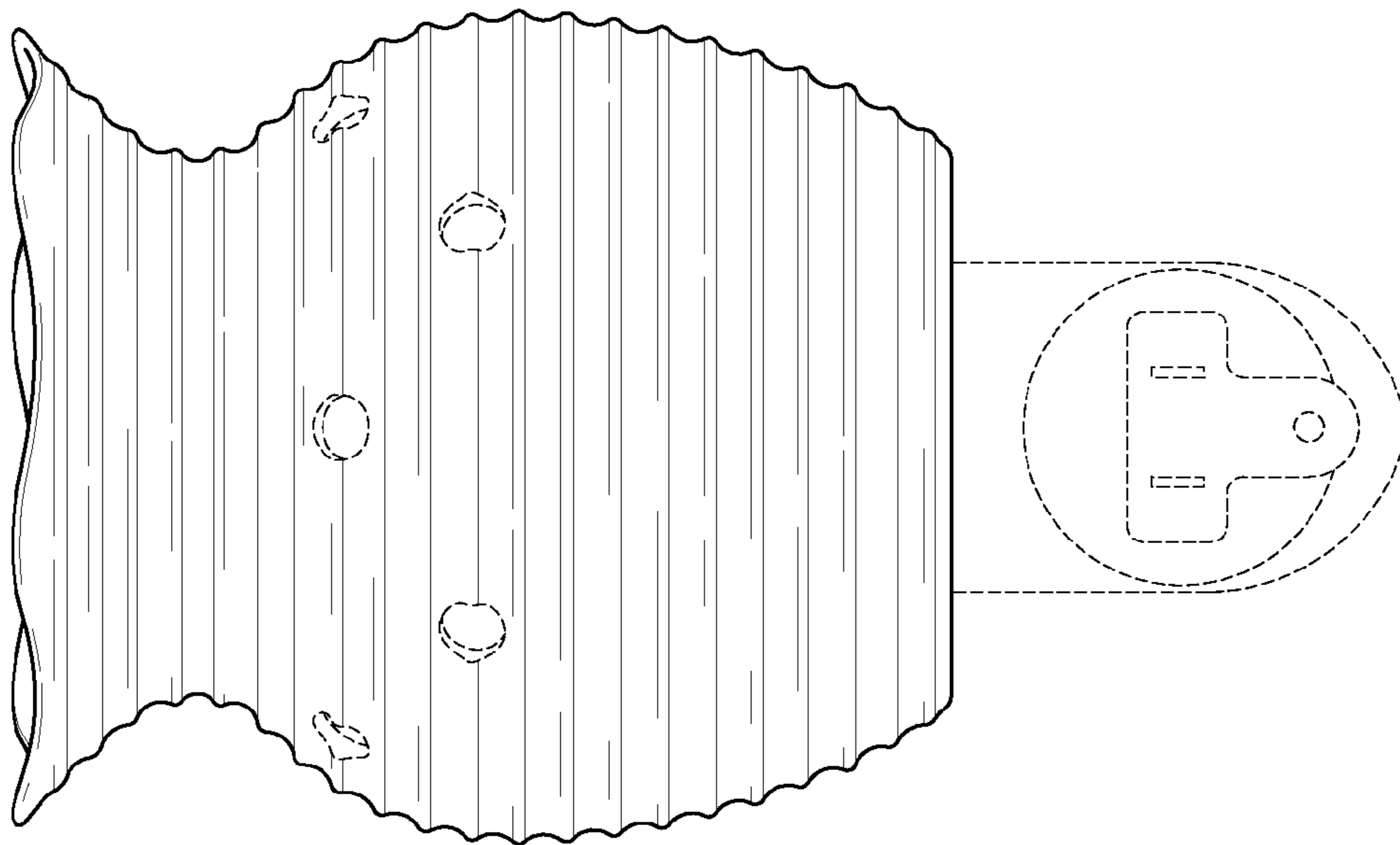




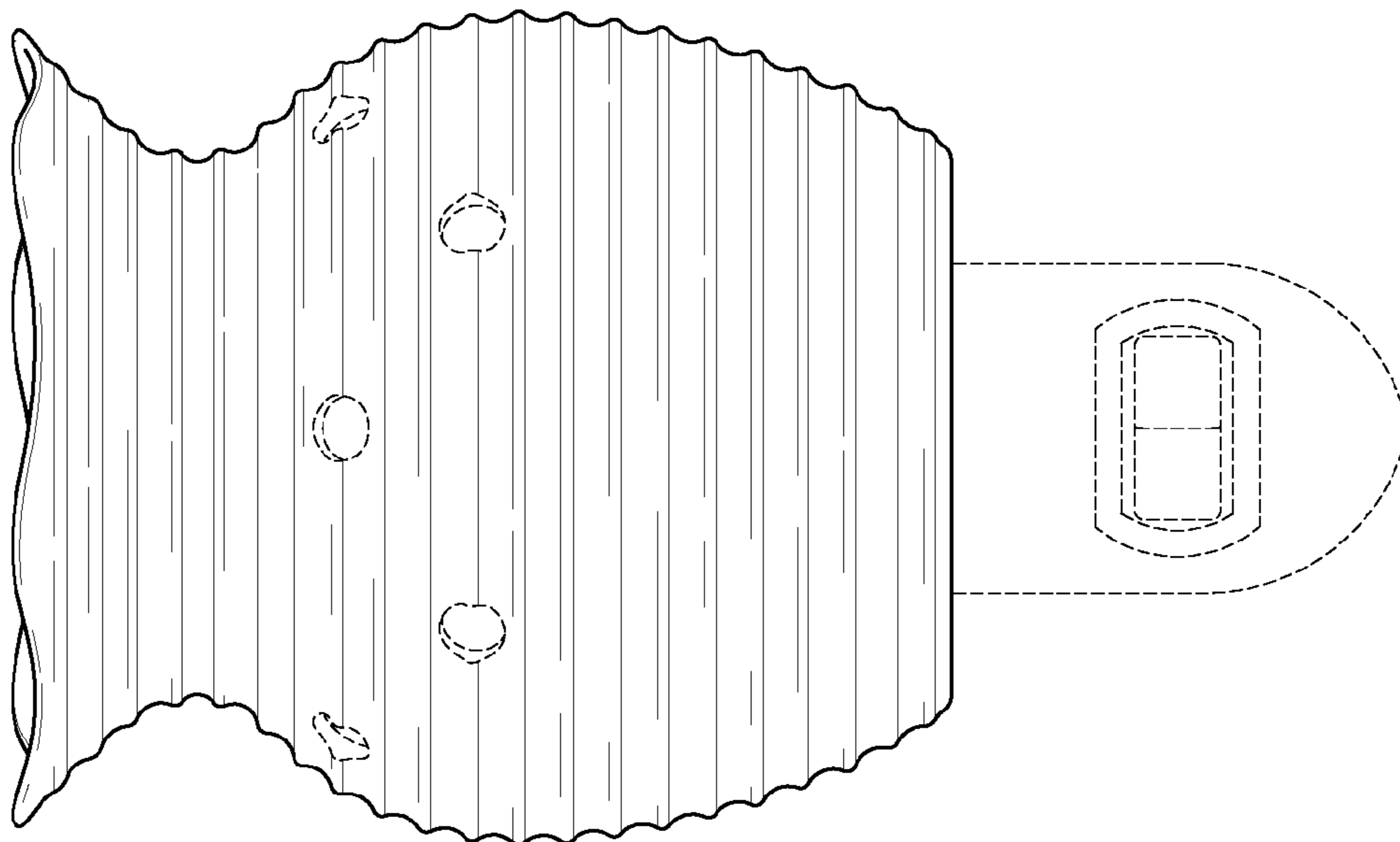
*Fig. 1*



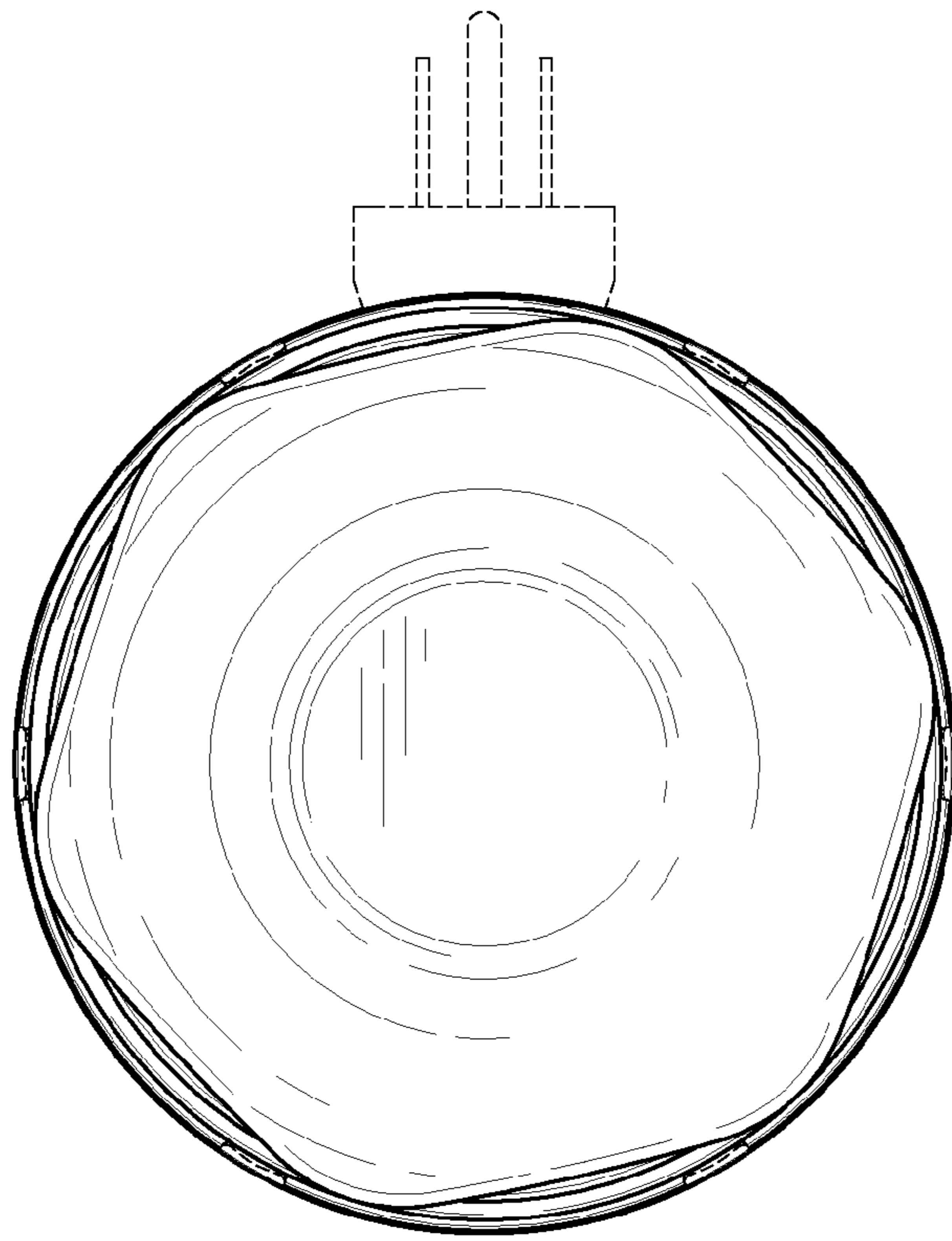
*Fig. 2*



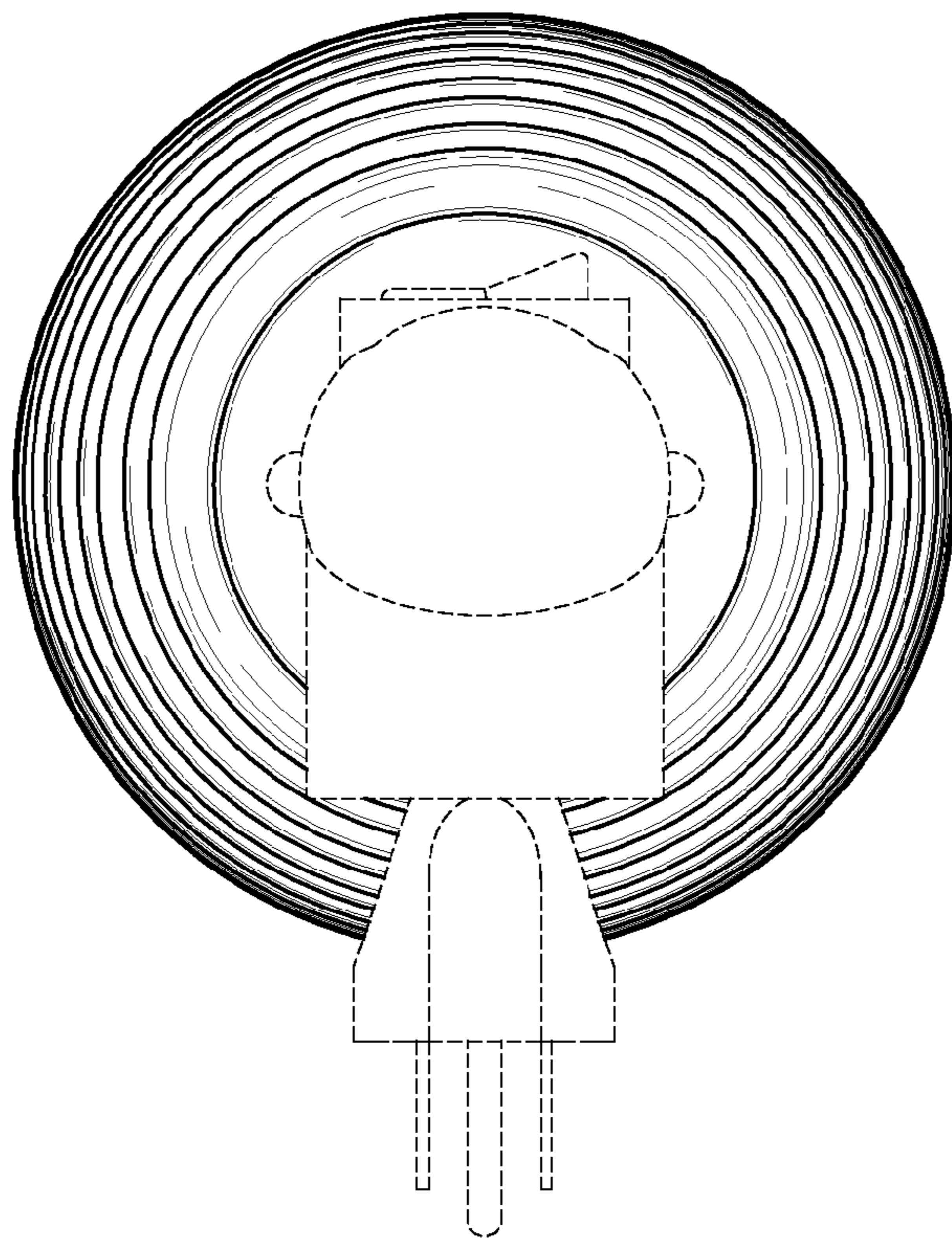
*Fig. 4*



*Fig. 3*



*Fig. 5*



*Fig. 6*