



US00D599854S

(12) **United States Design Patent**  
**Garza et al.**

(10) **Patent No.:** **US D599,854 S**  
(45) **Date of Patent:** **\*\* Sep. 8, 2009**

(54) **WRITING INSTRUMENT**

(75) Inventors: **Amy Garza**, Grapevine, TX (US); **Joel Johnson**, Grand Prairie, TX (US); **Brett Burris**, Grand Prairie, TX (US); **Wayne K. Schroeder**, Mansfield, TX (US)

(73) Assignee: **Lockheed Martin Corporation**, Grand Prairie, TX (US)

(\*\*) Term: **14 Years**

(21) Appl. No.: **29/319,401**

(22) Filed: **Jun. 9, 2008**

(51) **LOC (9) Cl.** ..... **19-06**

(52) **U.S. Cl.** ..... **D19/42**

(58) **Field of Classification Search** ..... D7/515,  
D7/604, 613, 619.2, 901; D19/35, 36, 41,  
D19/42, 43, 44, 45, 46, 47, 48, 49, 50, 51,  
D19/52, 53, 54, 55, 56, 57; 24/11 F, 11 P,  
24/11 R; 401/6, 52, 99, 100, 104, 105, 106,  
401/107, 108, 109, 192, 195, 243, 244, 245,  
401/246, 247; 244/3.21, 3.24; 708/107

See application file for complete search history.

(56) **References Cited**

**U.S. PATENT DOCUMENTS**

D98,496 S \* 2/1936 Britton ..... D19/46

(Continued)

**OTHER PUBLICATIONS**

Missile Pen by Cole Industries, Inc., as shown on www.advertisingpens.net, dated Dec. 9, 2006 (2 pages).\*

*Primary Examiner*—Elizabeth A Albert

*Assistant Examiner*—Karen E Eldridge Powers

(74) *Attorney, Agent, or Firm*—Daren C. Davis; James E. Walton

(57) **CLAIM**

An ornamental design for a writing instrument, as shown and described.

**DESCRIPTION**

FIG. 1 is a perspective view of a first embodiment of a writing instrument;

FIG. 2 is a right side, elevational view thereof, the side opposite being a mirror image thereof;

FIG. 3 is a top, plan view thereof;

FIG. 4 is a bottom, plan view thereof;

FIG. 5 is a front, elevational view thereof;

FIG. 6 is a rear, elevational view thereof.

FIG. 7 is a perspective view of a second embodiment of a writing instrument;

FIG. 8 is a right side, elevational view thereof, the side opposite being a mirror image thereof;

FIG. 9 is a top, plan view thereof;

FIG. 10 is a bottom, plan view thereof;

FIG. 11 is a front, elevational view thereof;

FIG. 12 is a rear, elevational view thereof;

FIG. 13 is a perspective view thereof, with the cap of the writing instrument removed;

FIG. 14 is a perspective view of a third embodiment of a writing instrument;

FIG. 15 is a right side, elevational view thereof, the side opposite being a mirror image thereof;

FIG. 16 is a top plan view thereof;

FIG. 17 is a bottom, plan view thereof;

FIG. 18 is a front, elevational view thereof; and,

FIG. 19 is a rear elevational view thereof.

The broken lines shown in FIGS. 1–5 and 13–18 in the drawings are environmental matter and form no part of the claimed design.

**1 Claim, 13 Drawing Sheets**

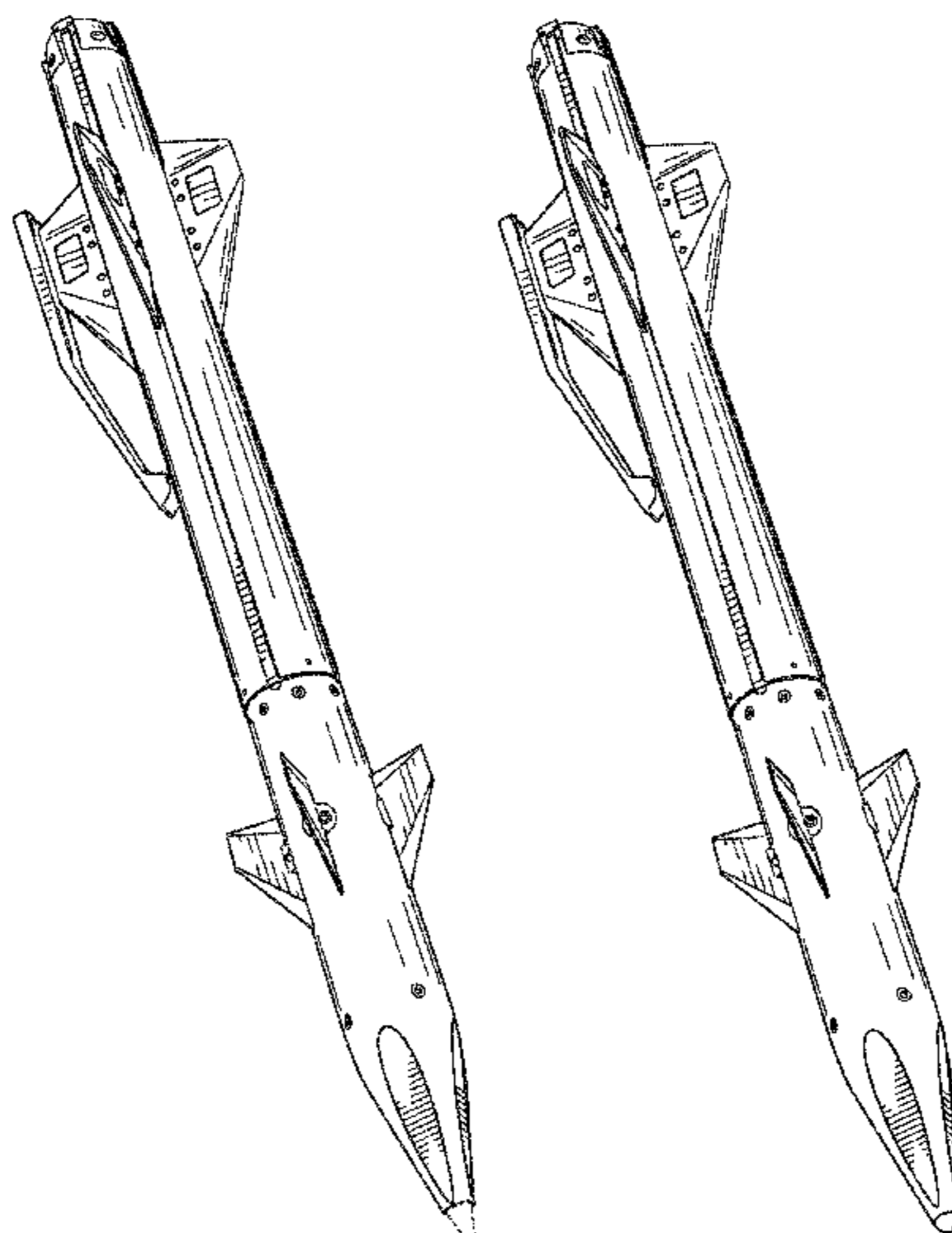

# US D599,854 S

Page 2

## U.S. PATENT DOCUMENTS

D110,810 S *	8/1938	Kahn	.....	D19/49	D350,984 S *	9/1994	Huang	.....	D19/42
D112,750 S *	12/1938	Blake	.....	D19/48	5,415,487 A *	5/1995	Rukan et al.	.....	401/117
2,646,776 A *	7/1953	Scholz	.....	401/211	D367,671 S *	3/1996	Pijlman	.....	D19/42
2,871,824 A *	2/1959	Sams	.....	401/217	D372,497 S *	8/1996	Lamber	.....	D19/48
2,918,751 A *	12/1959	Johnson	.....	89/1.806	D394,085 S *	5/1998	Leedy	.....	D19/42
2,951,465 A *	9/1960	Weisser et al.	.....	401/116	5,806,791 A *	9/1998	Hatalsky et al.	.....	244/3.24
3,378,216 A *	4/1968	Oss et al.	.....	244/3.24	5,950,963 A *	9/1999	Speicher et al.	.....	244/3.21
3,776,490 A *	12/1973	Weis	.....	244/3.21	D416,043 S *	11/1999	Arthur et al.	.....	D19/55
3,917,416 A *	11/1975	Steyer	.....	401/34	5,975,461 A *	11/1999	Ullrich	.....	244/3.21
D258,219 S *	2/1981	Oka	.....	D19/49	D443,300 S *	6/2001	Kim et al.	.....	D19/36
4,938,620 A *	7/1990	Weiss et al.	.....	401/260	D461,499 S *	8/2002	Boyle et al.	.....	D19/36
5,169,253 A *	12/1992	Tsao	.....	401/195	6,462,322 B1 *	10/2002	Gauggel et al.	.....	244/3.1
D341,851 S *	11/1993	Bulgari	.....	D19/51	6,848,648 B2 *	2/2005	Klestadt et al.	.....	244/3.23

\* cited by examiner

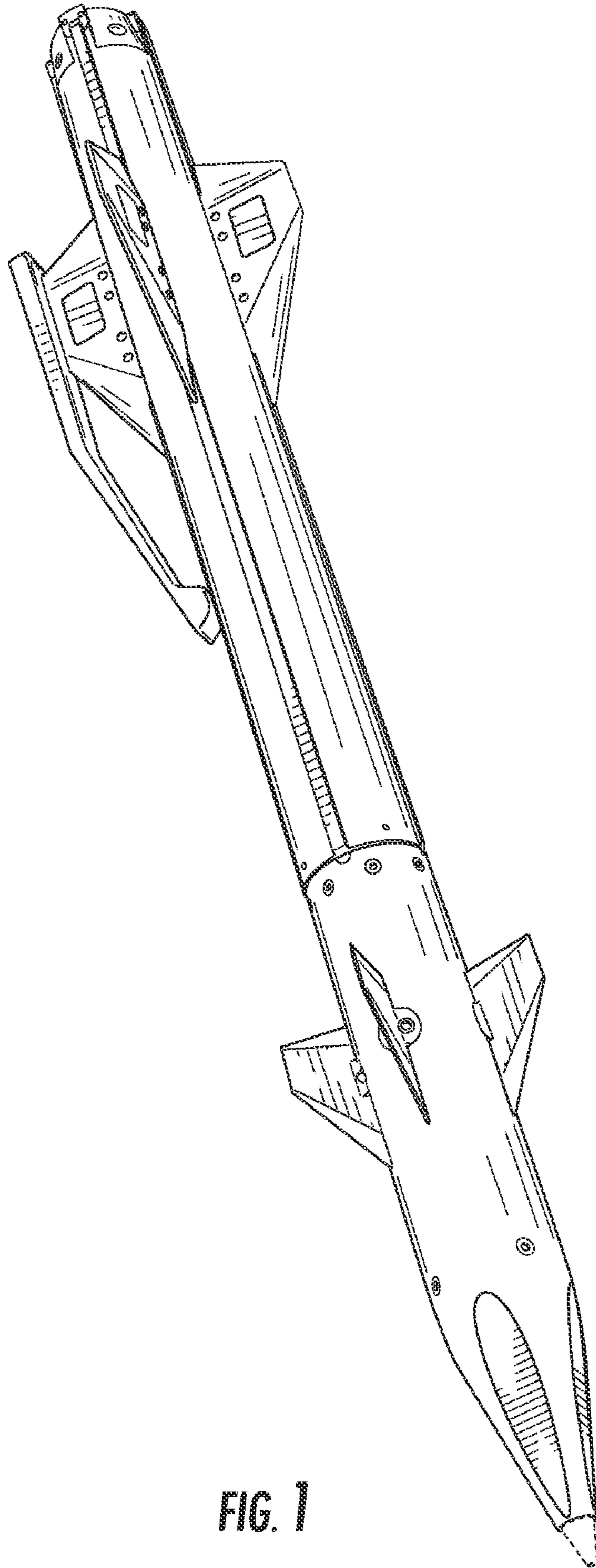

FIG. 1

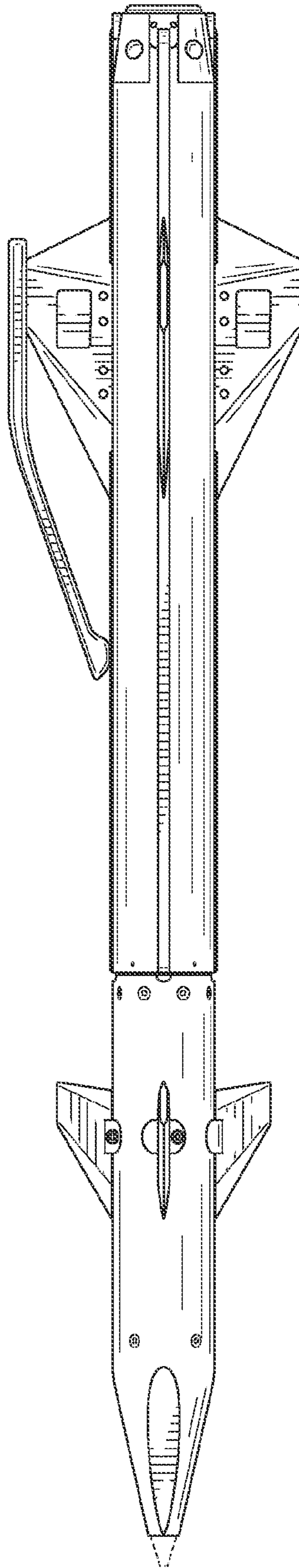
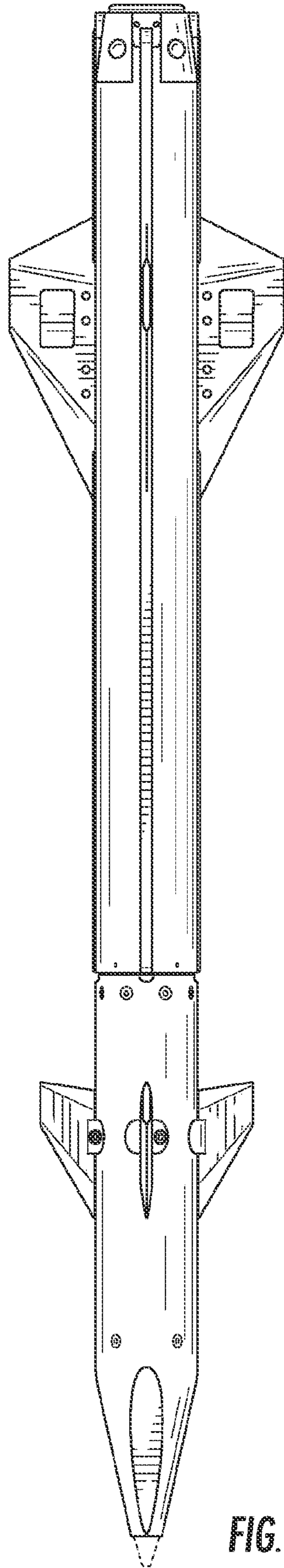
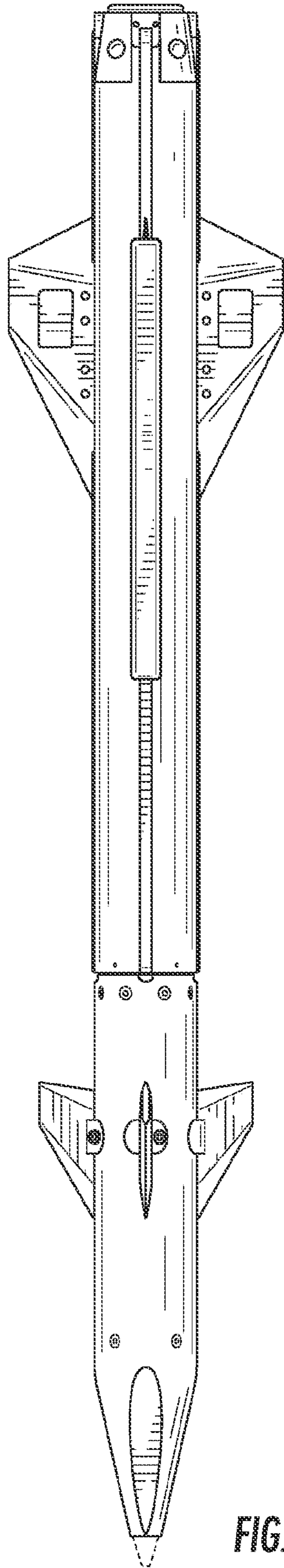
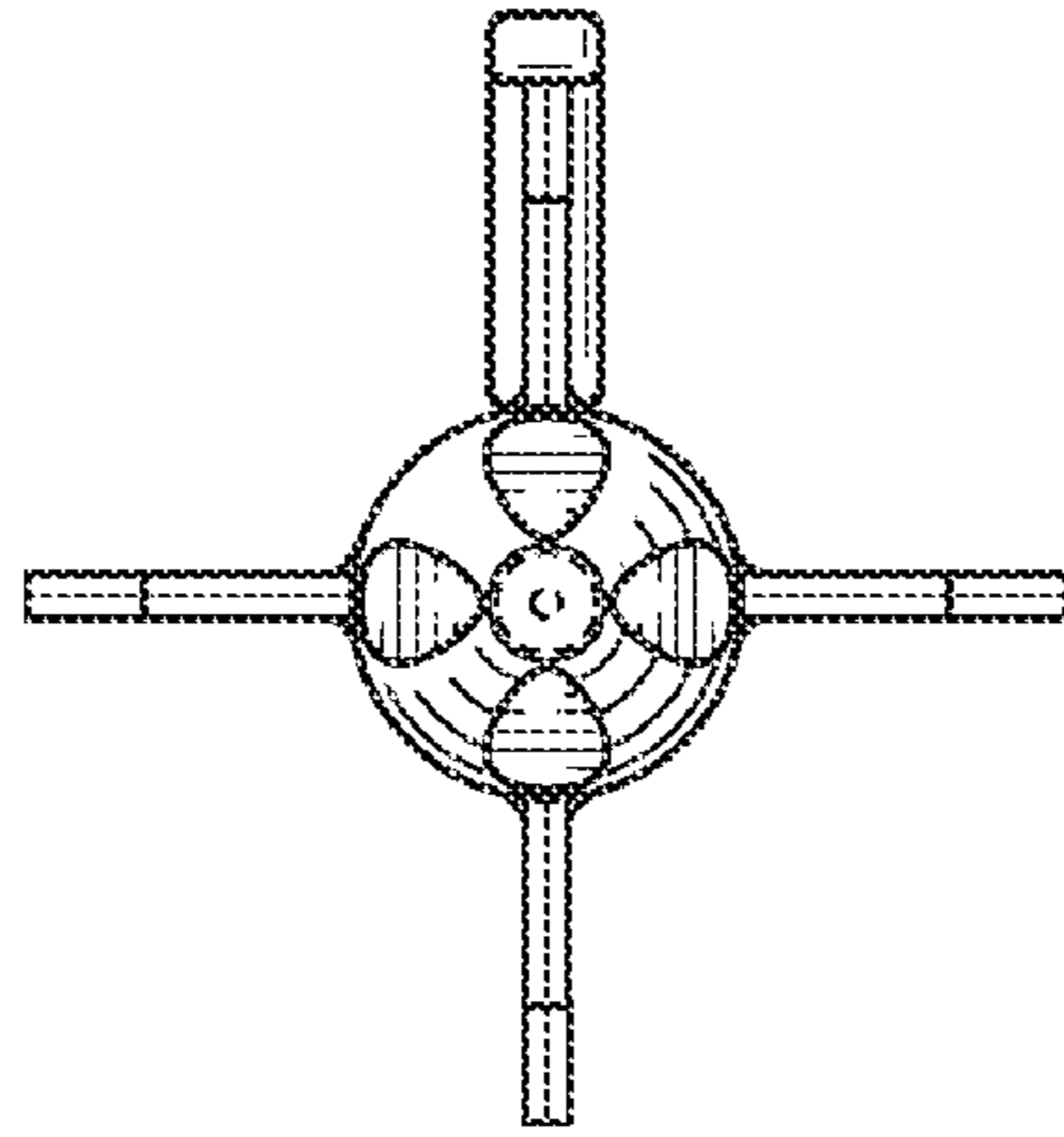
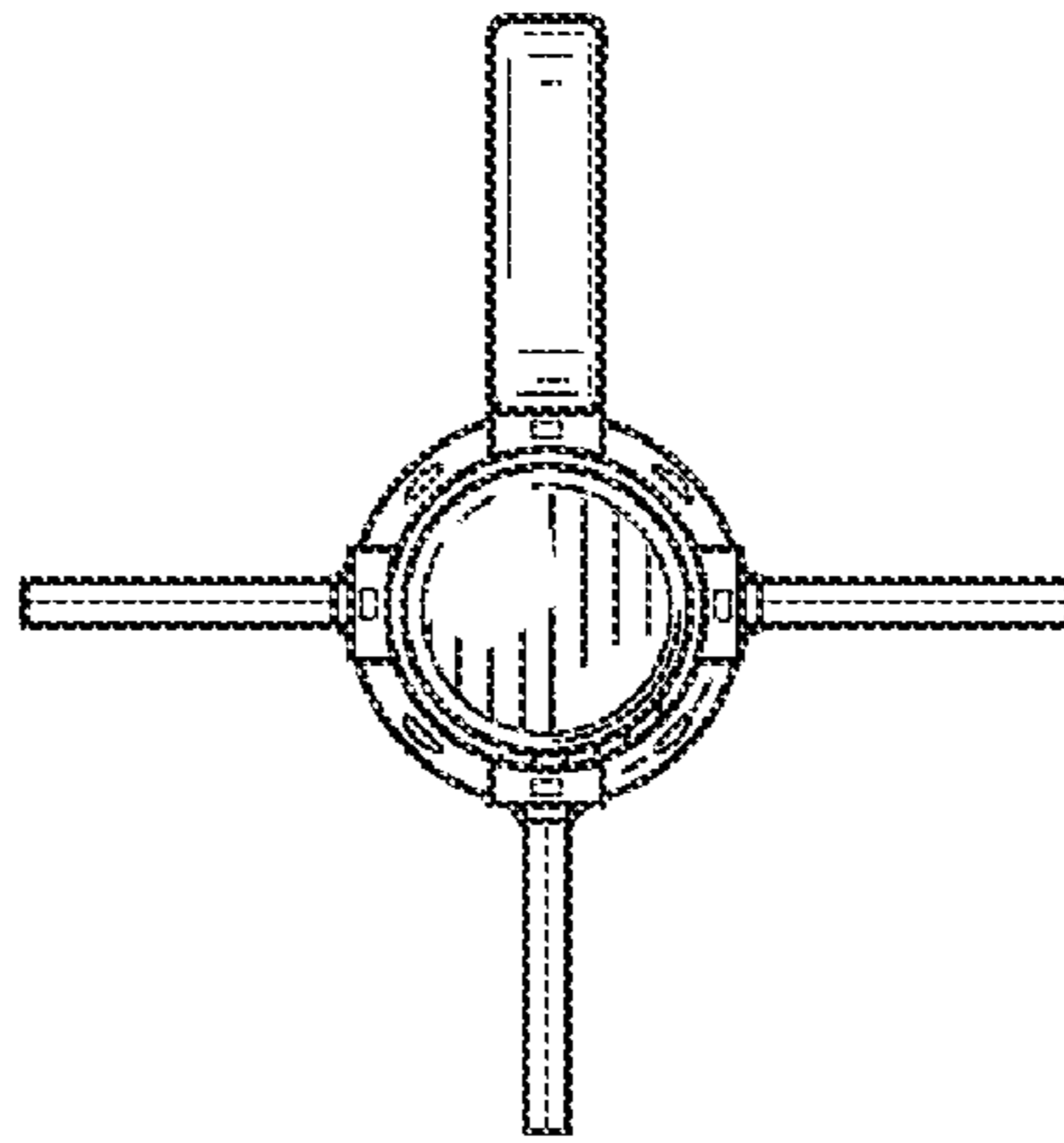

FIG. 2

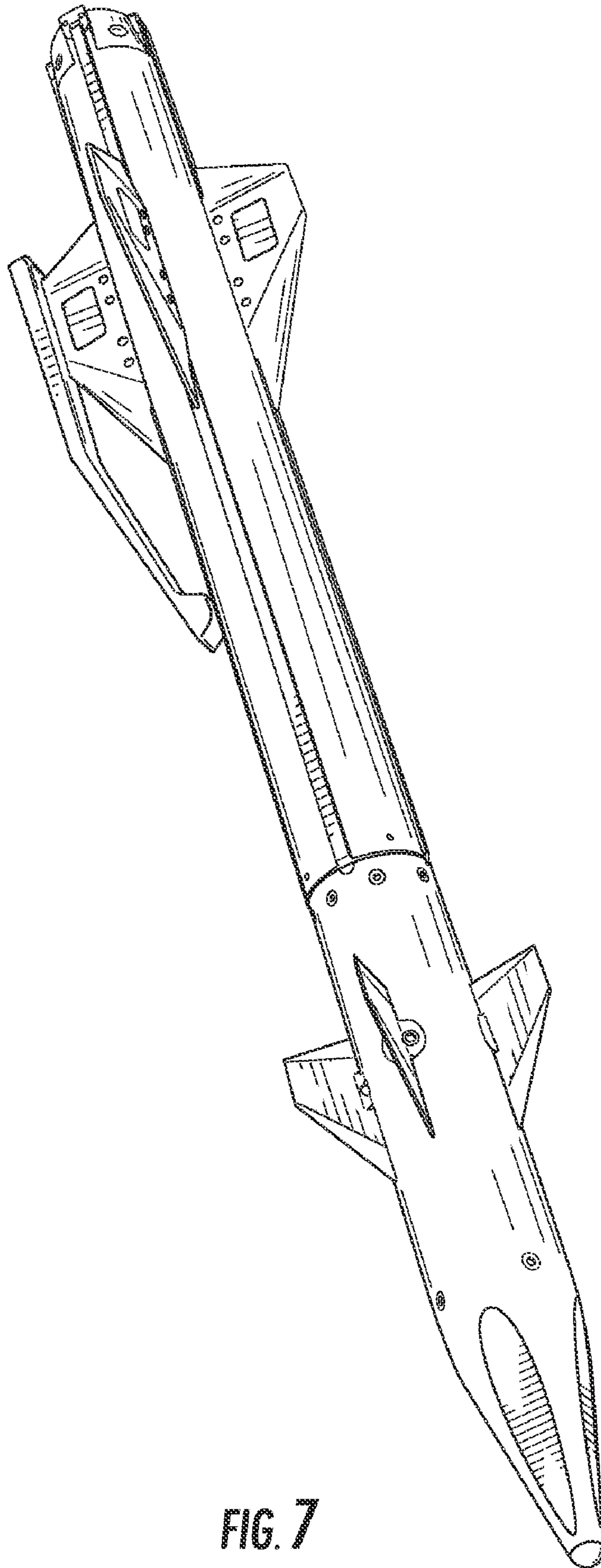



**FIG. 5**



**FIG. 6**



**FIG. 7**

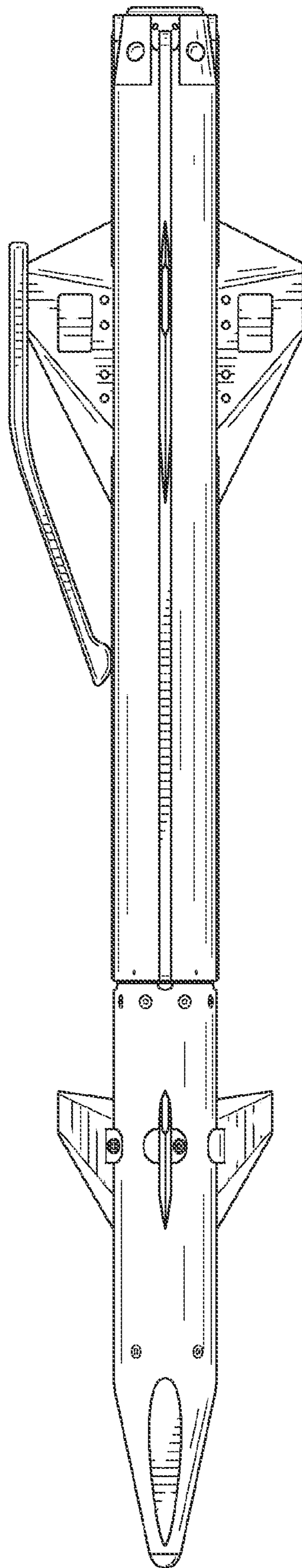
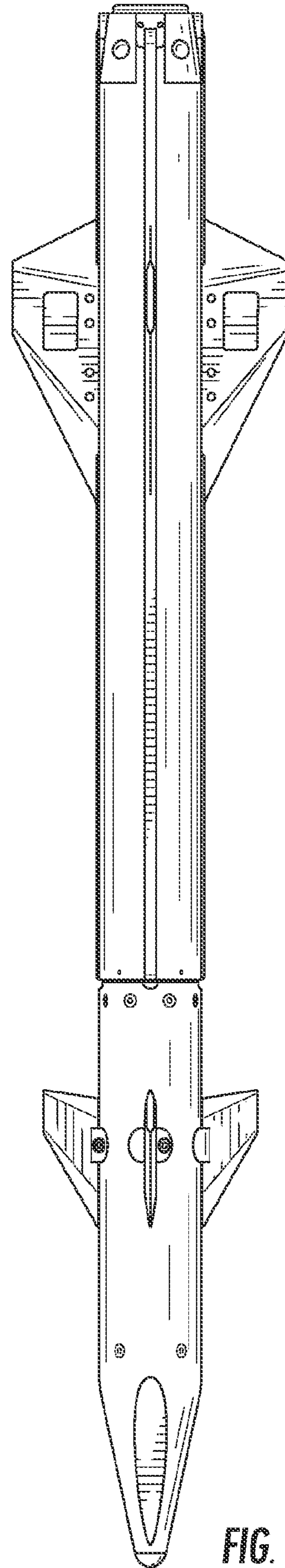
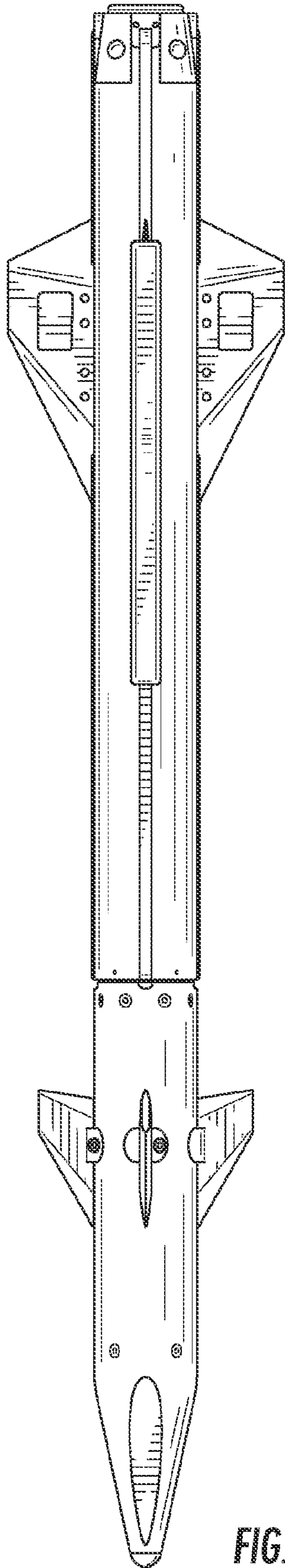
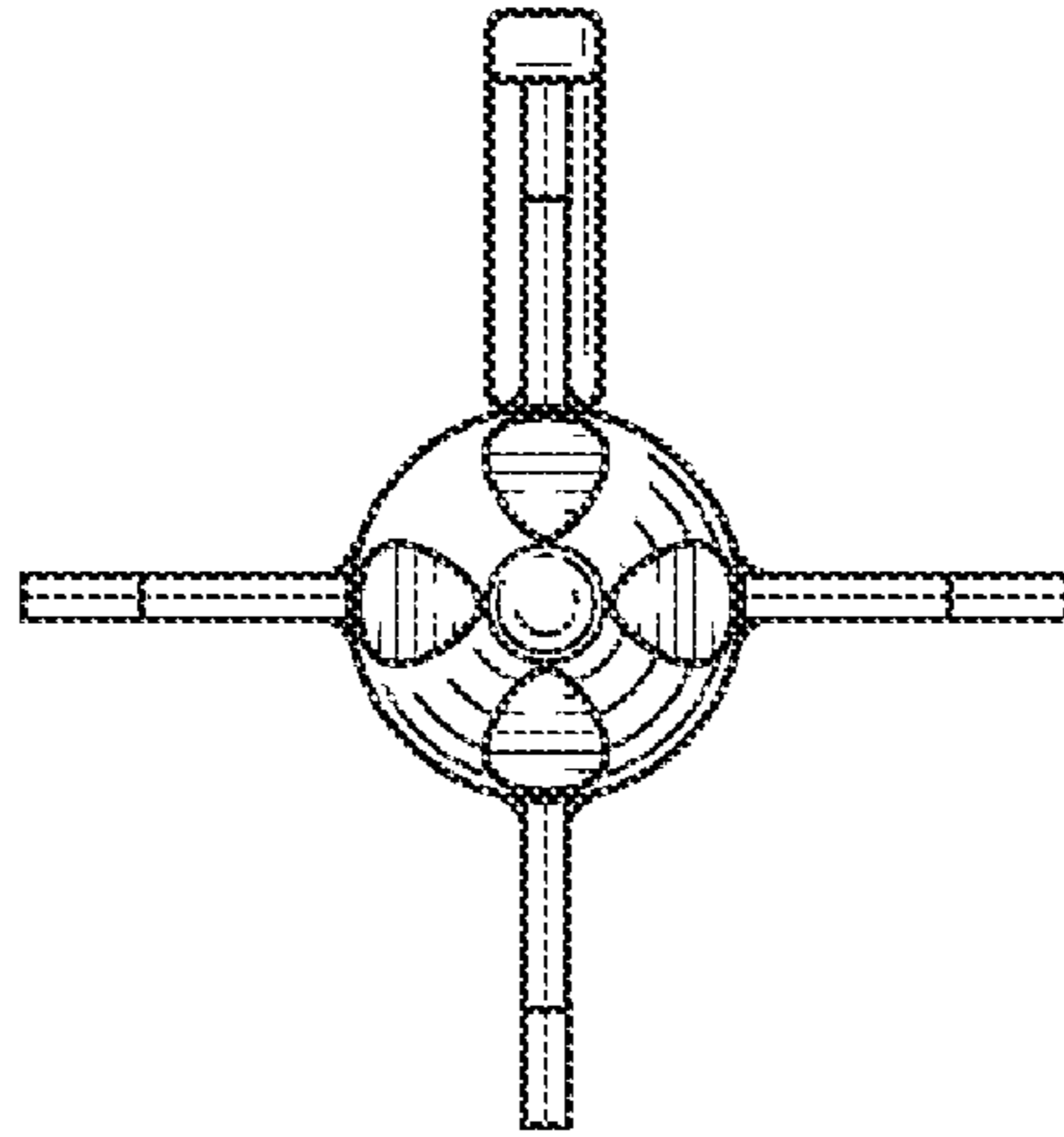

FIG. 8







**FIG. 11**

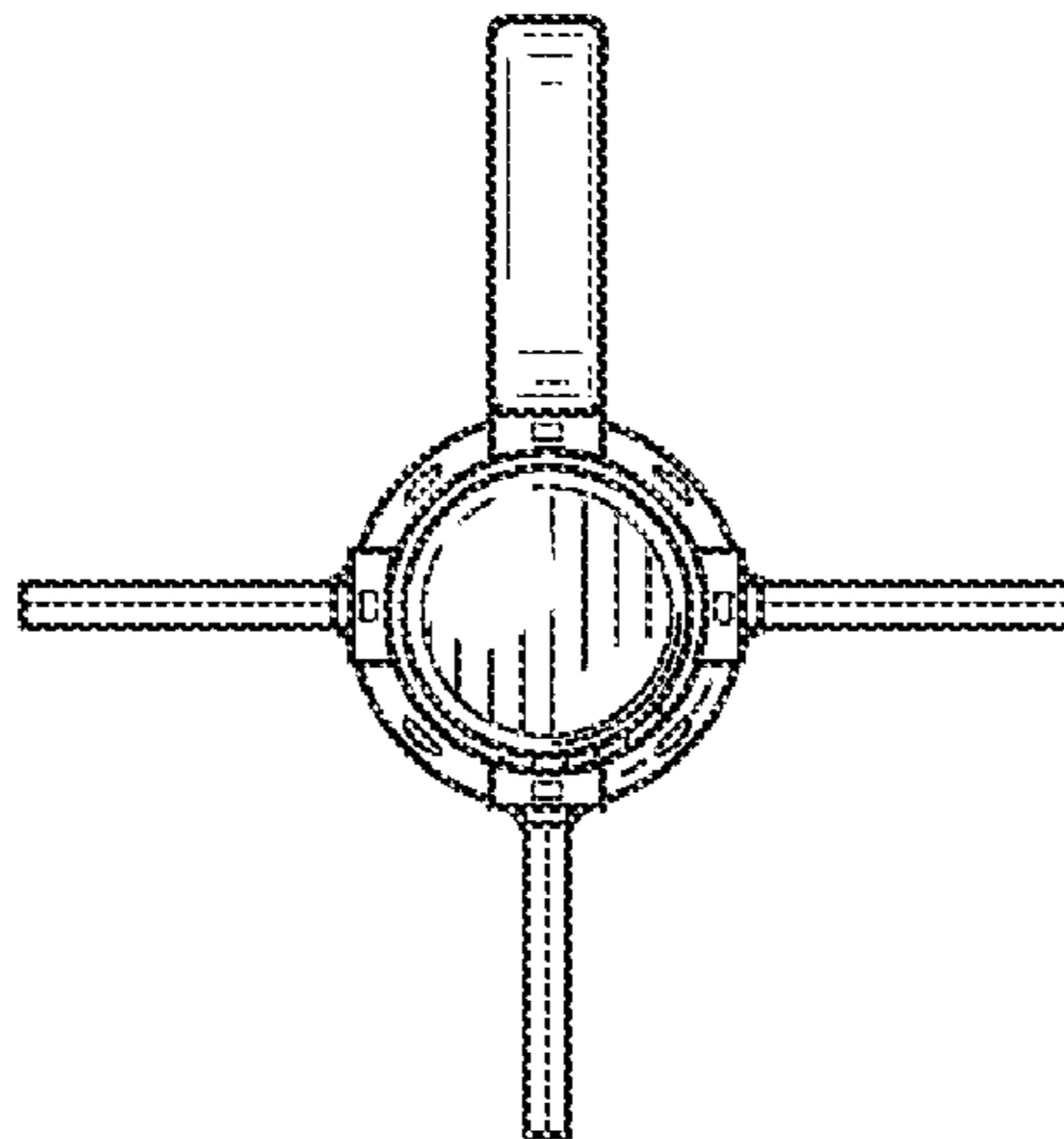

**FIG. 12**

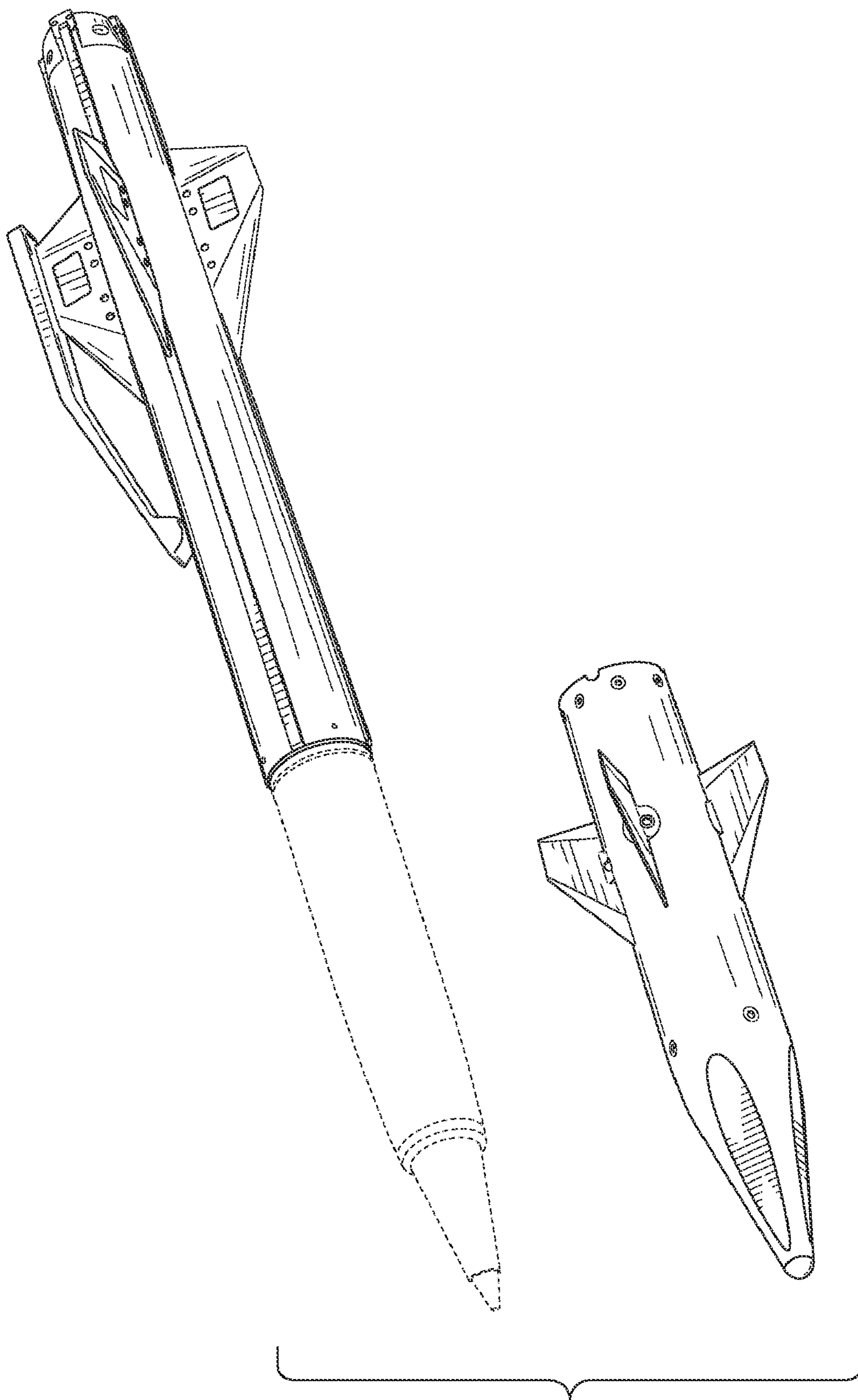

FIG. 13

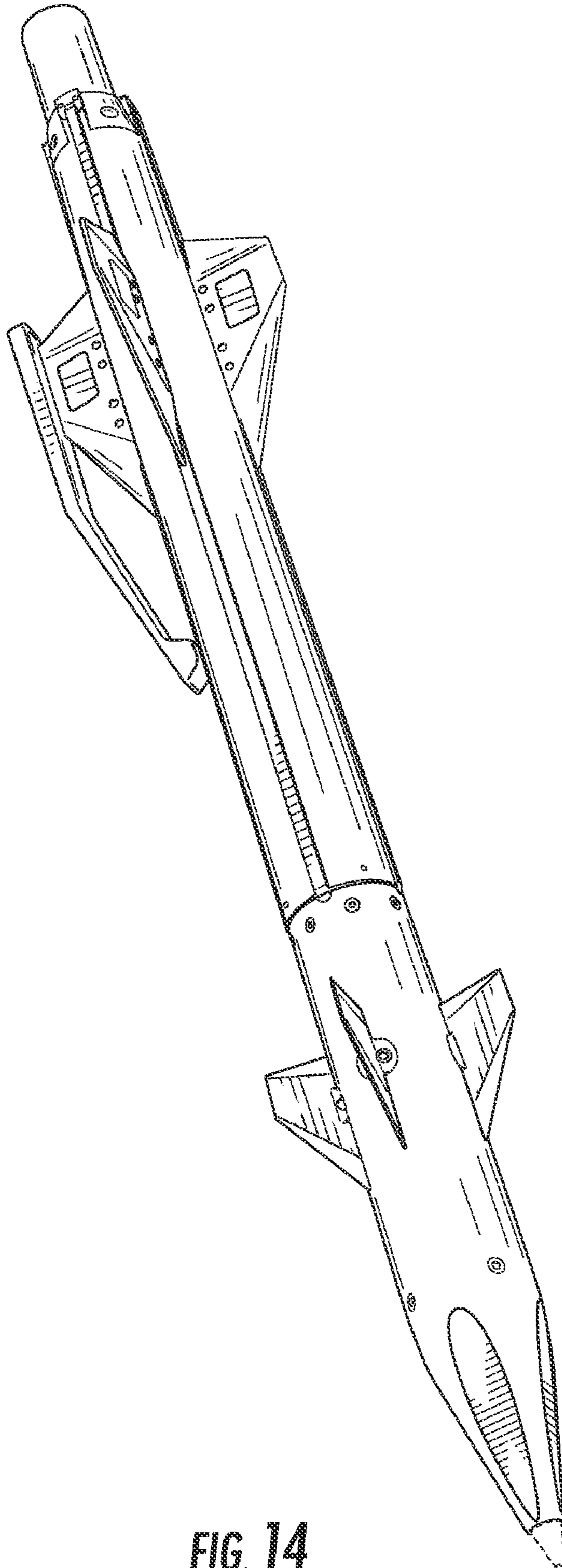

FIG. 14

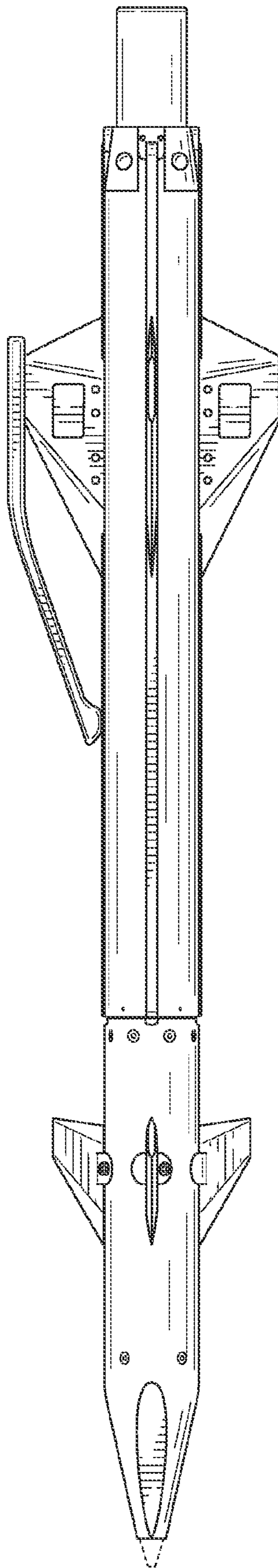

FIG. 15

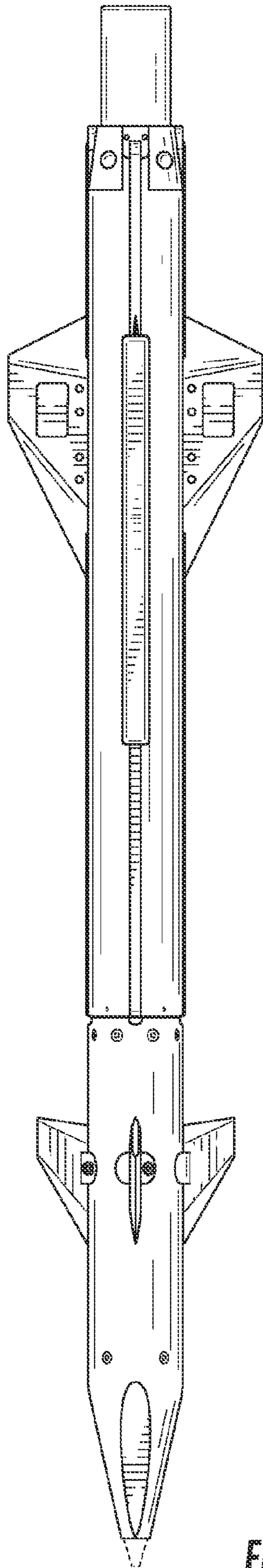

FIG. 16

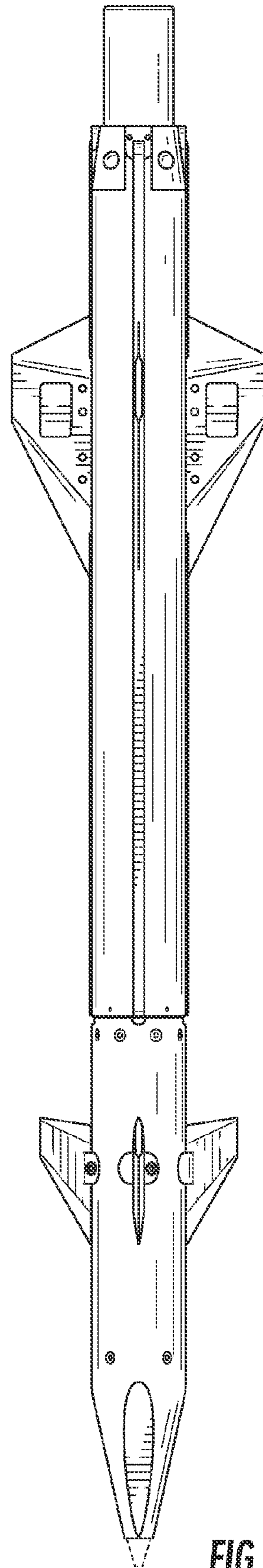
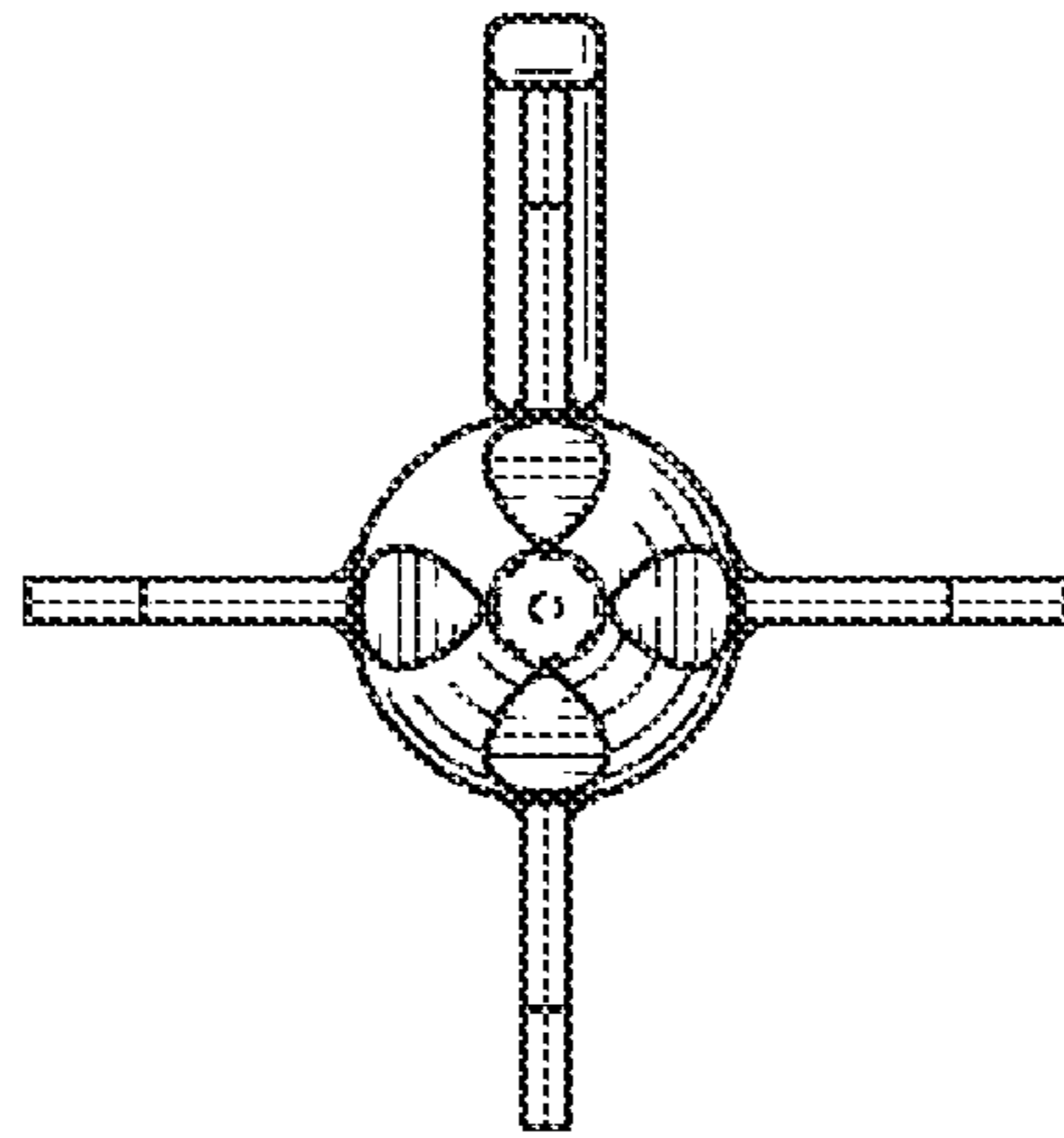
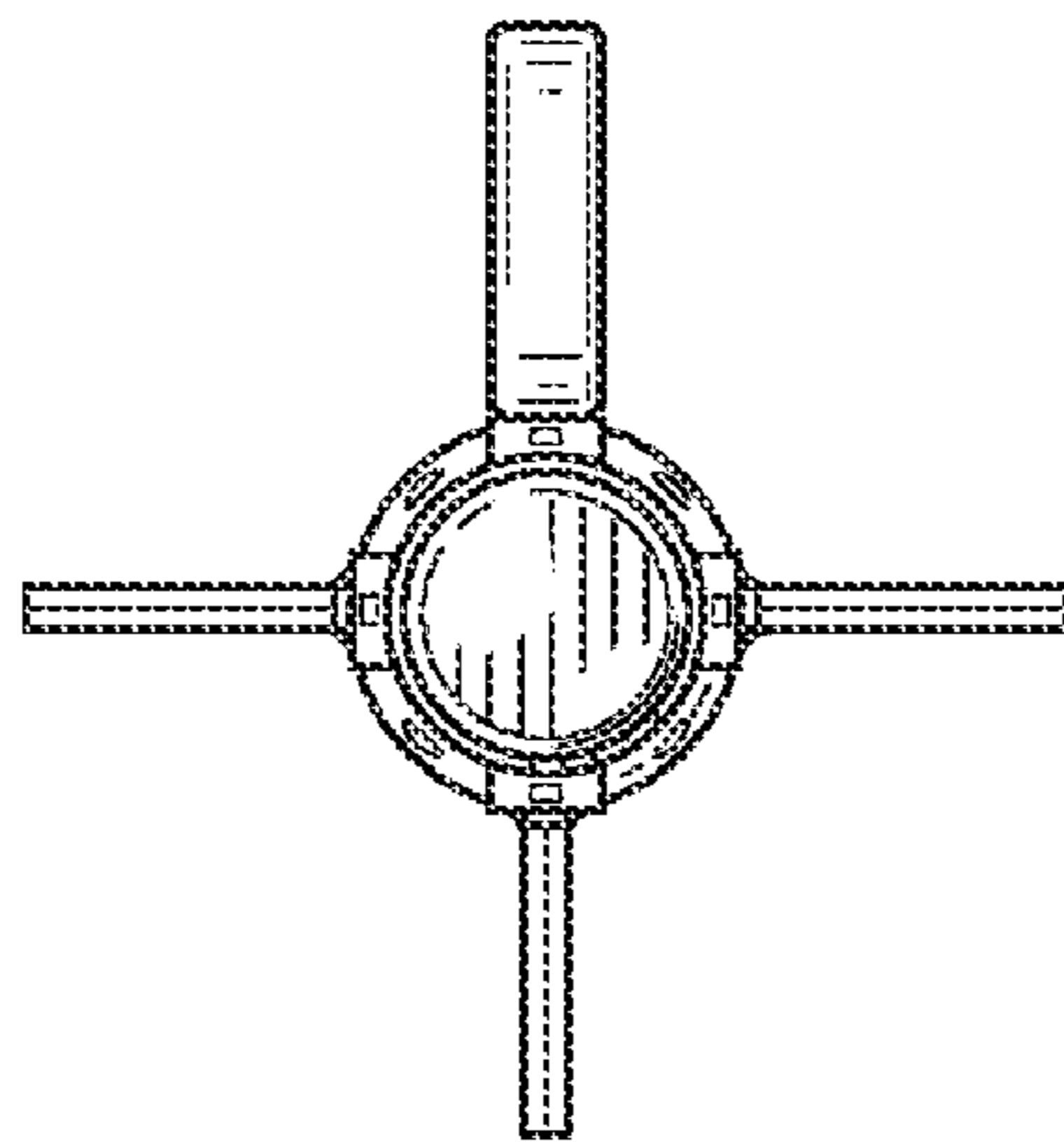

FIG. 17



**FIG. 18**



**FIG. 19**