



US00D599646S

(12) **United States Design Patent**  
**Meyers**

(10) **Patent No.:** **US D599,646 S**

(45) **Date of Patent:** **\*\* Sep. 8, 2009**

(54) **HANGER**

(76) **Inventor:** **Steven D. Meyers**, 105 Nelson Pkwy.,  
Cherry Valley, IL (US) 61016

(\*\*) **Term:** **14 Years**

(21) **Appl. No.:** **29/301,479**

(22) **Filed:** **Mar. 4, 2008**

(51) **LOC (9) Cl.** ..... **08-05**

(52) **U.S. Cl.** ..... **D8/370**

(58) **Field of Classification Search** ..... D8/370,  
D8/373; 248/302–303, 339

See application file for complete search history.

(56) **References Cited**

**U.S. PATENT DOCUMENTS**

4,138,019	A	2/1979	Smith	
D274,037	S	5/1984	Crim et al.	
D275,917	S	10/1984	Einhorn	
D304,545	S	11/1989	Hurrelbrink	
D312,961	S	12/1990	Evenson	
D326,021	S	5/1992	Evenson	
D336,730	S	6/1993	Hofman	
D342,889	S	1/1994	Adams	
5,368,267	A	11/1994	Howard	
5,413,297	A	5/1995	Adams	
5,738,319	A	4/1998	Grassi	
D423,916	S *	5/2000	Kalat	D8/370
6,254,050	B1 *	7/2001	Albrecht et al.	248/303
D464,560	S *	10/2002	Kalat	D8/370
D464,869	S *	10/2002	Kalat	D8/370
D465,724	S	11/2002	Goodman	

6,715,526	B1	4/2004	Brownfield et al.	
D498,411	S *	11/2004	Randall	D8/370
D499,956	S *	12/2004	Wall	D8/370
D515,827	S *	2/2006	Steendyk	D6/317
7,207,088	B2	4/2007	Adams et al.	
7,234,671	B2	6/2007	Avinger et al.	
D546,171	S *	7/2007	Tabert	D8/370
2002/0104937	A1	8/2002	Avinger	
2003/0173483	A1	9/2003	Yeh	
2007/0205346	A1	9/2007	Jackson et al.	

\* cited by examiner

*Primary Examiner*—Holly H Baynham

(74) *Attorney, Agent, or Firm*—Leydig, Voit & Mayer Ltd.

(57) **CLAIM**

An ornamental design for a hanger, as shown and described.

**DESCRIPTION**

FIG. 1 is a perspective view of the hanger illustrating top, side and end surfaces;

FIG. 2 is a view illustrating an end of the hanger;

FIG. 3 is a view illustrating an end of the hanger opposing the end of FIG. 2;

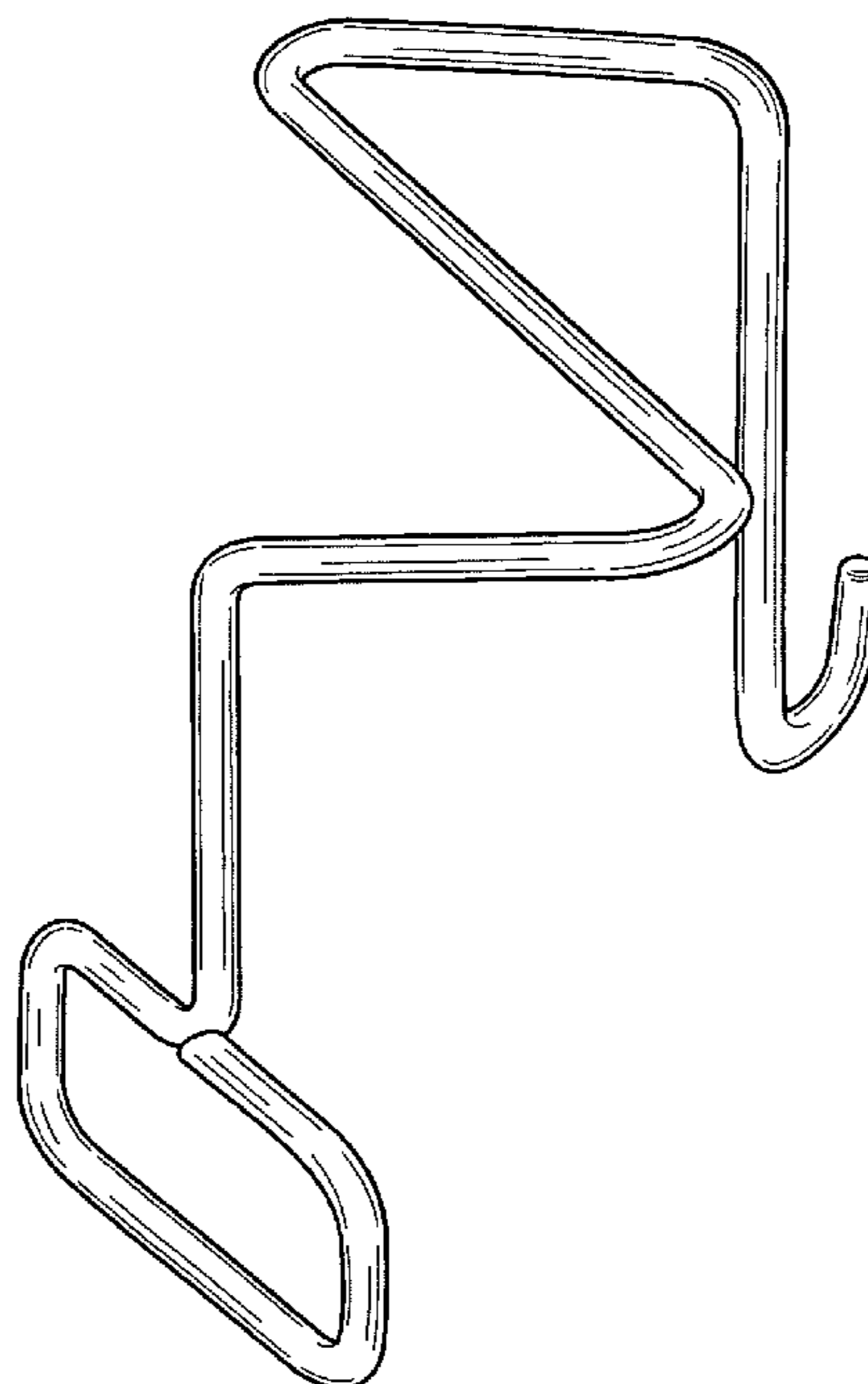
FIG. 4 is a view illustrating a side of the hanger;

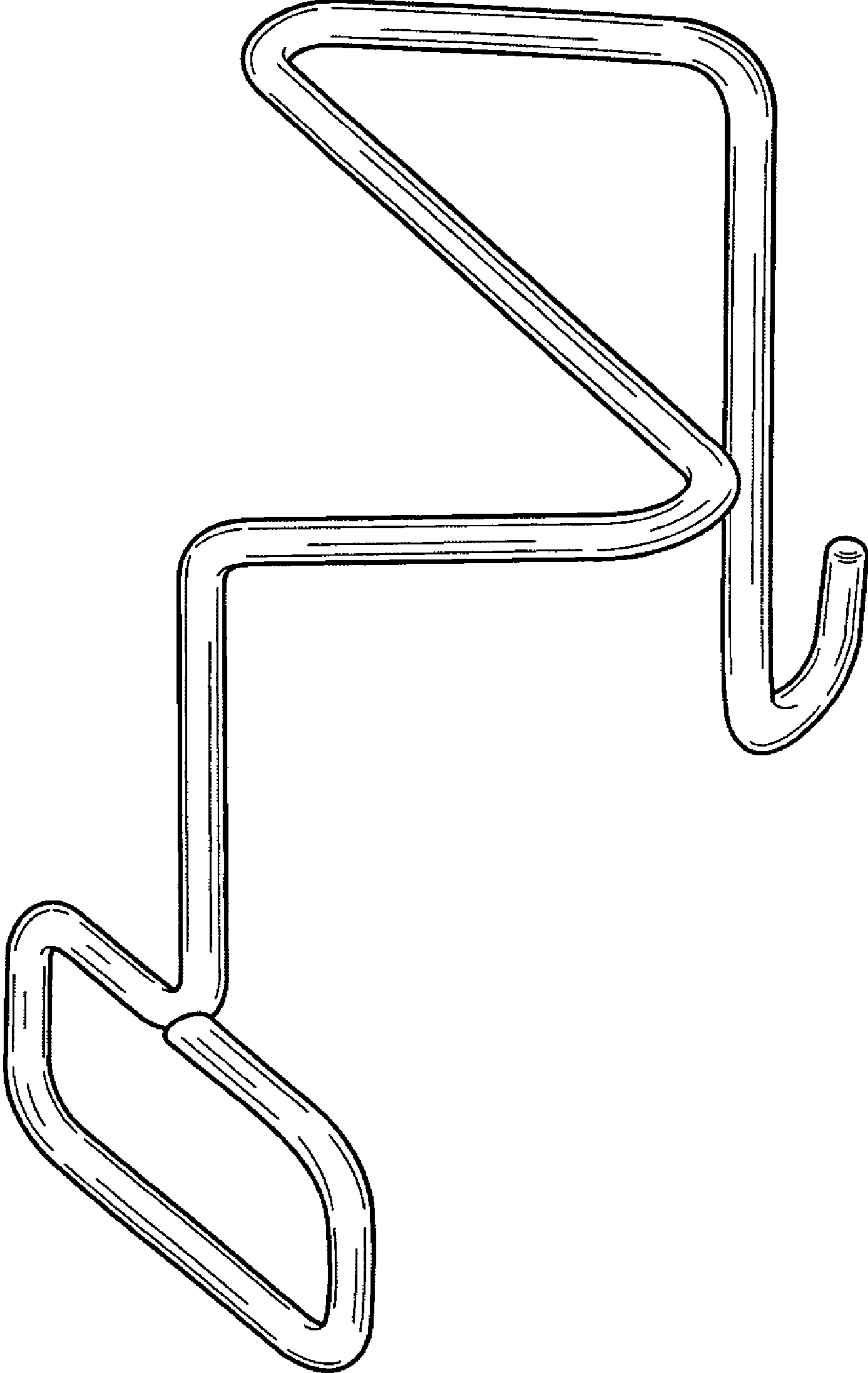
FIG. 5 is a view illustrating a side of the hanger opposing the side of FIG. 4;

FIG. 6 is a top plan view of the hanger; and,

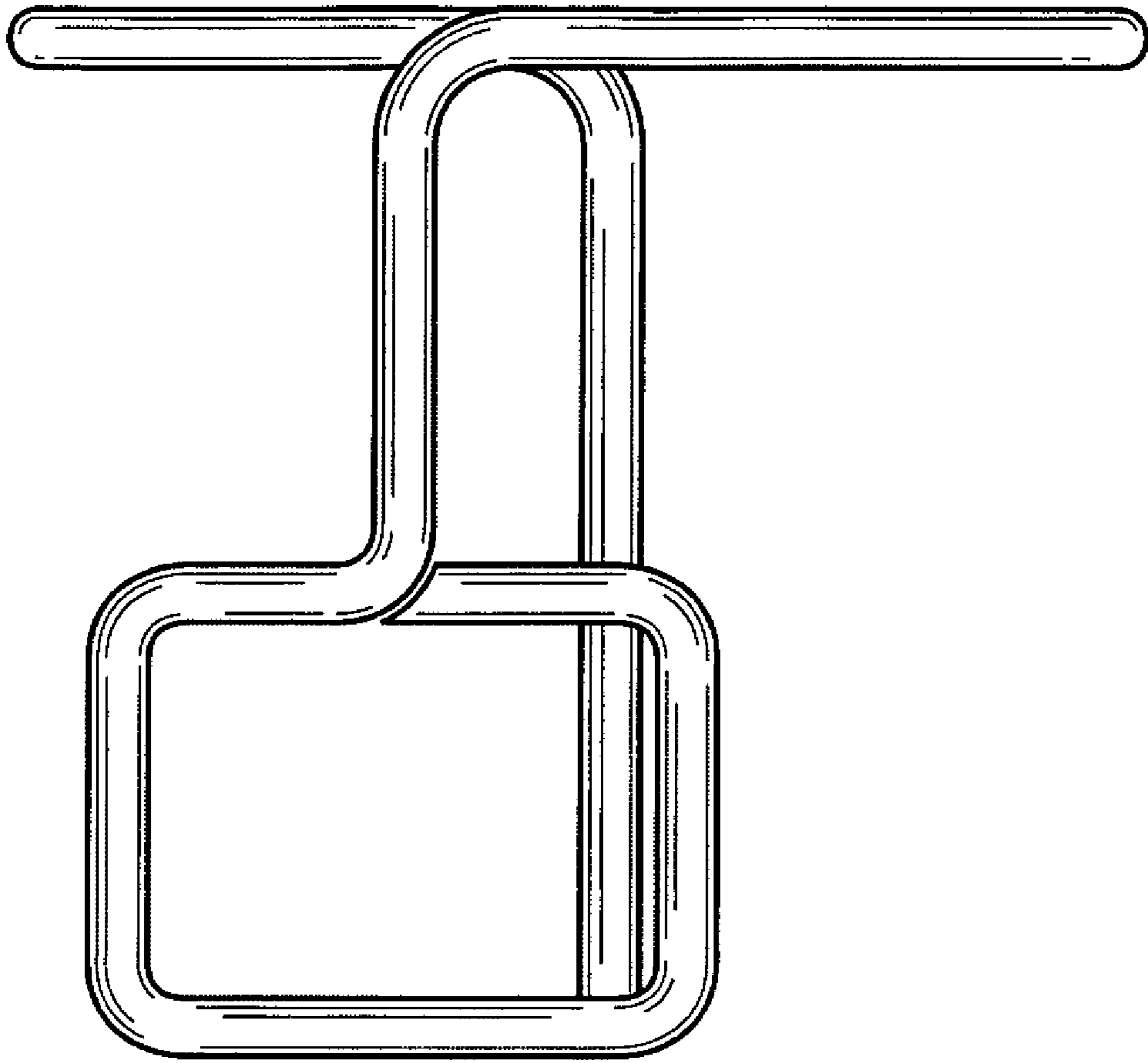
FIG. 7 is a bottom plan view of the hanger.

**1 Claim, 7 Drawing Sheets**

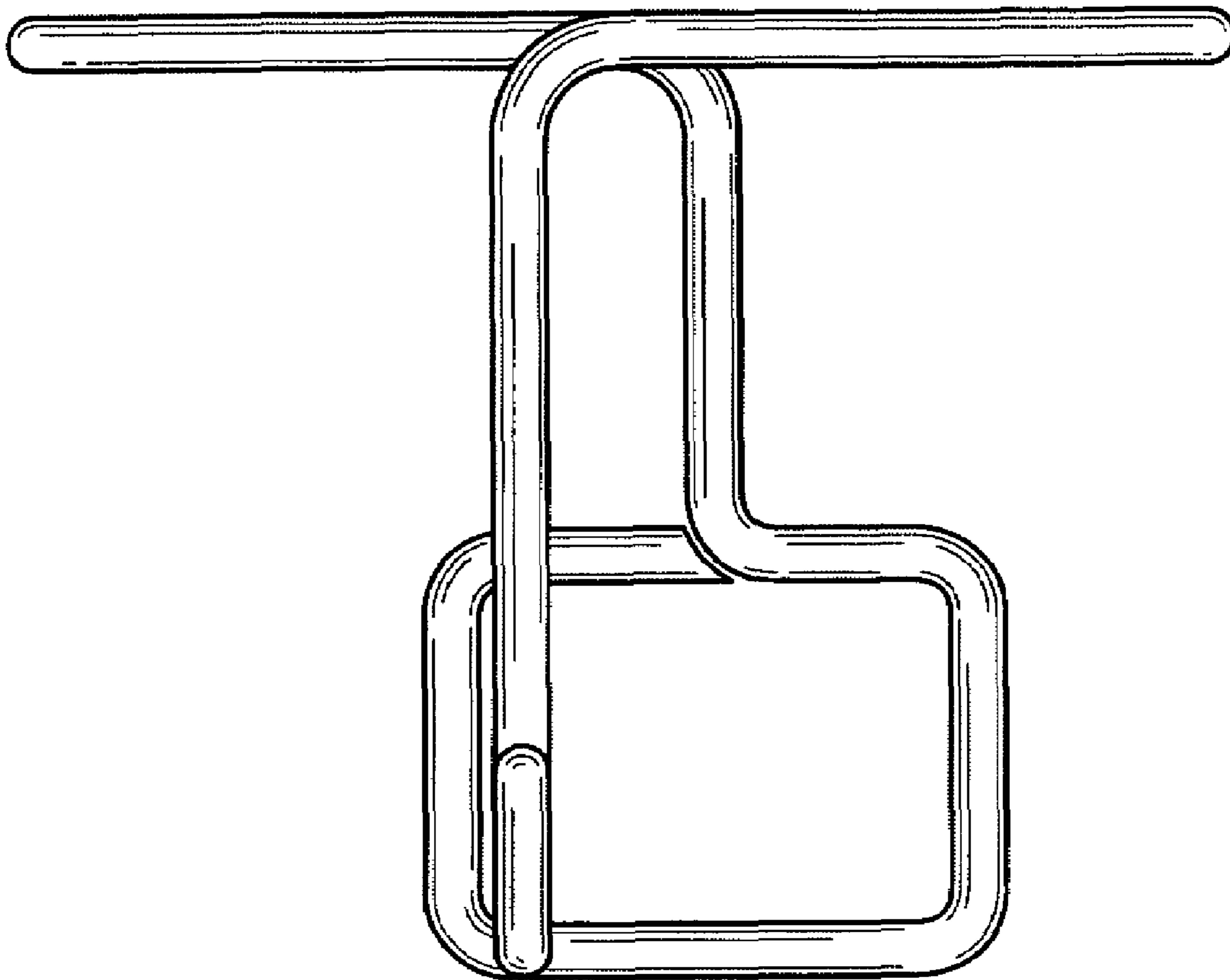




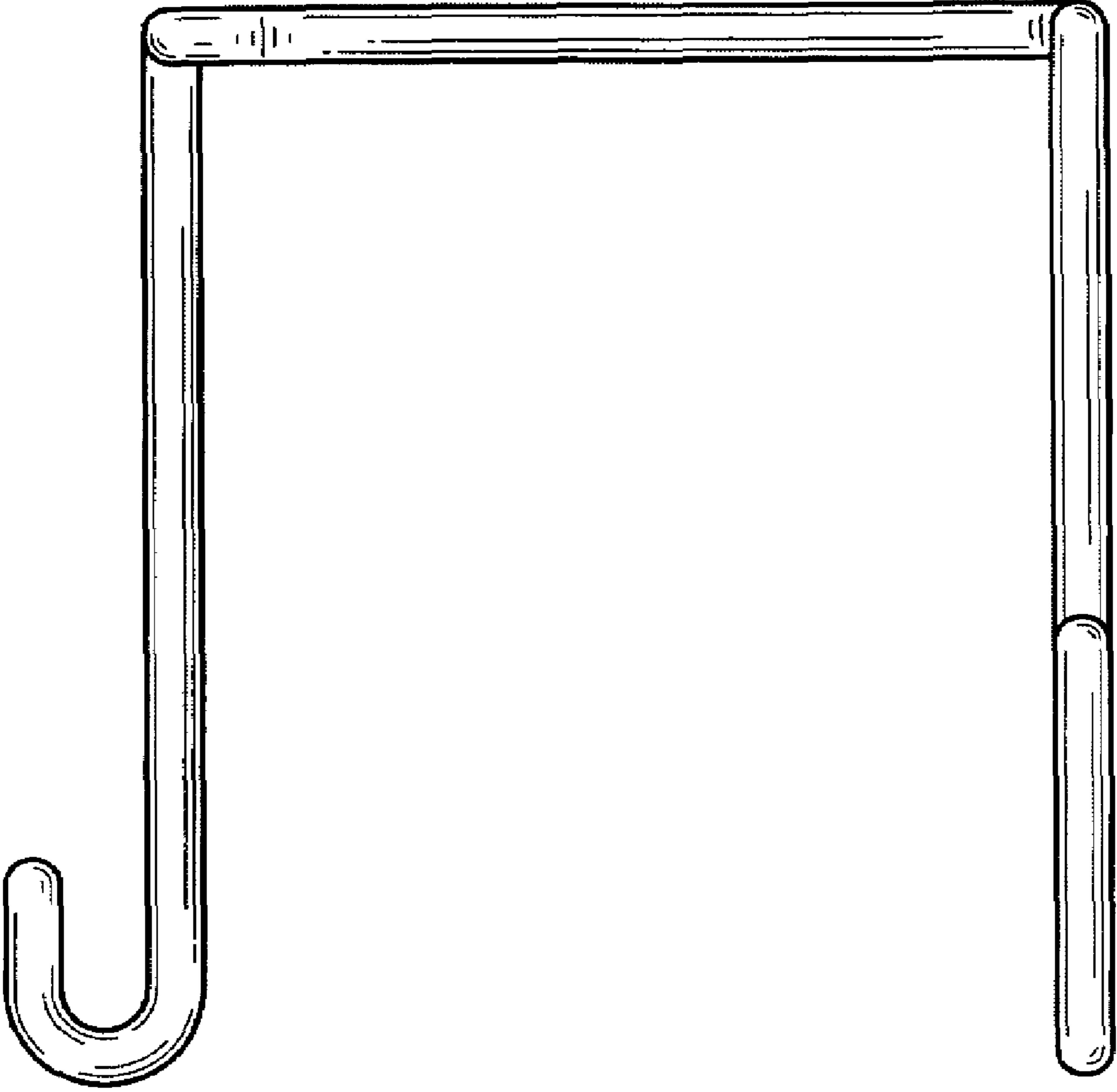
**FIG. 1**



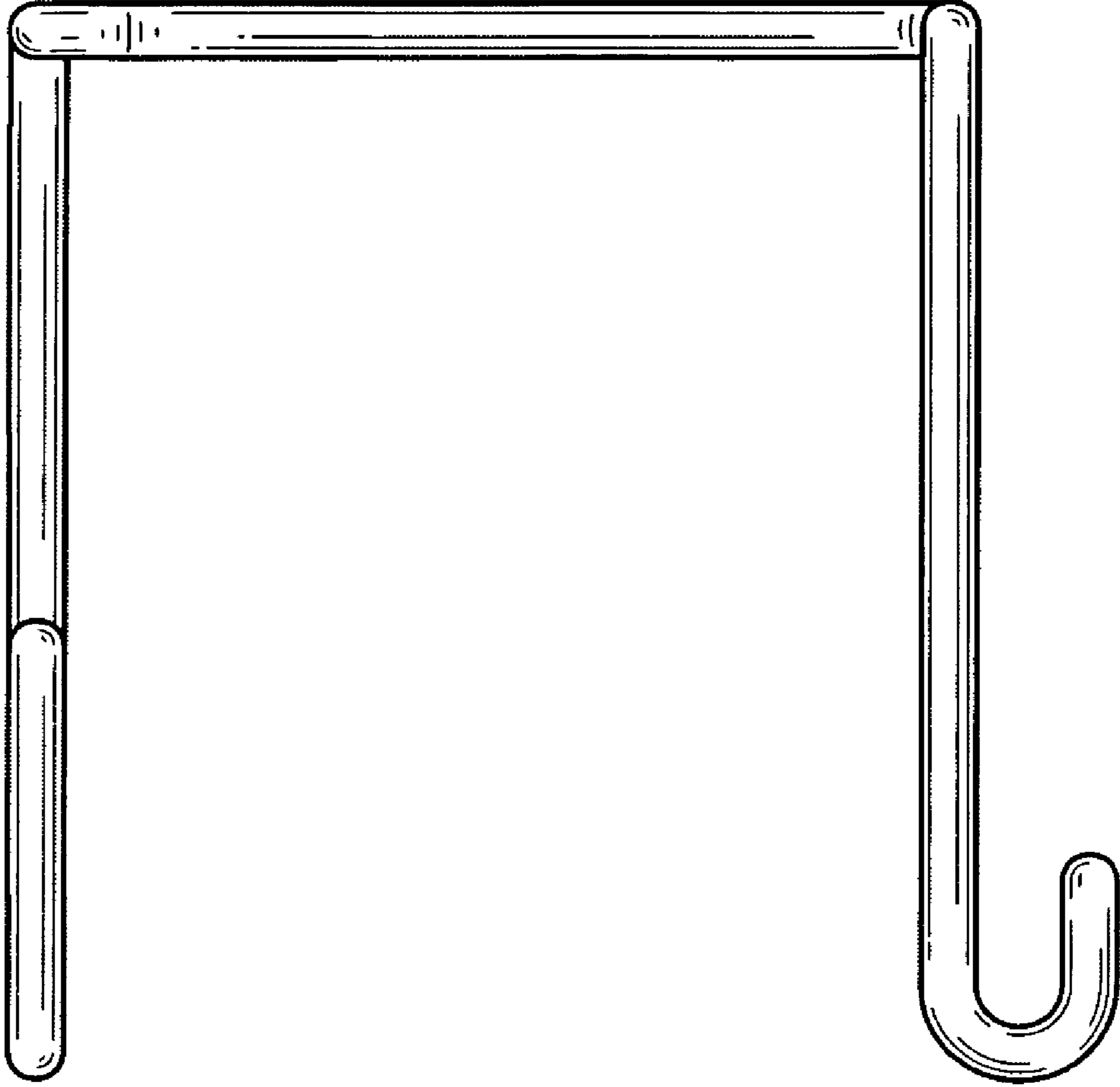
**FIG. 2**



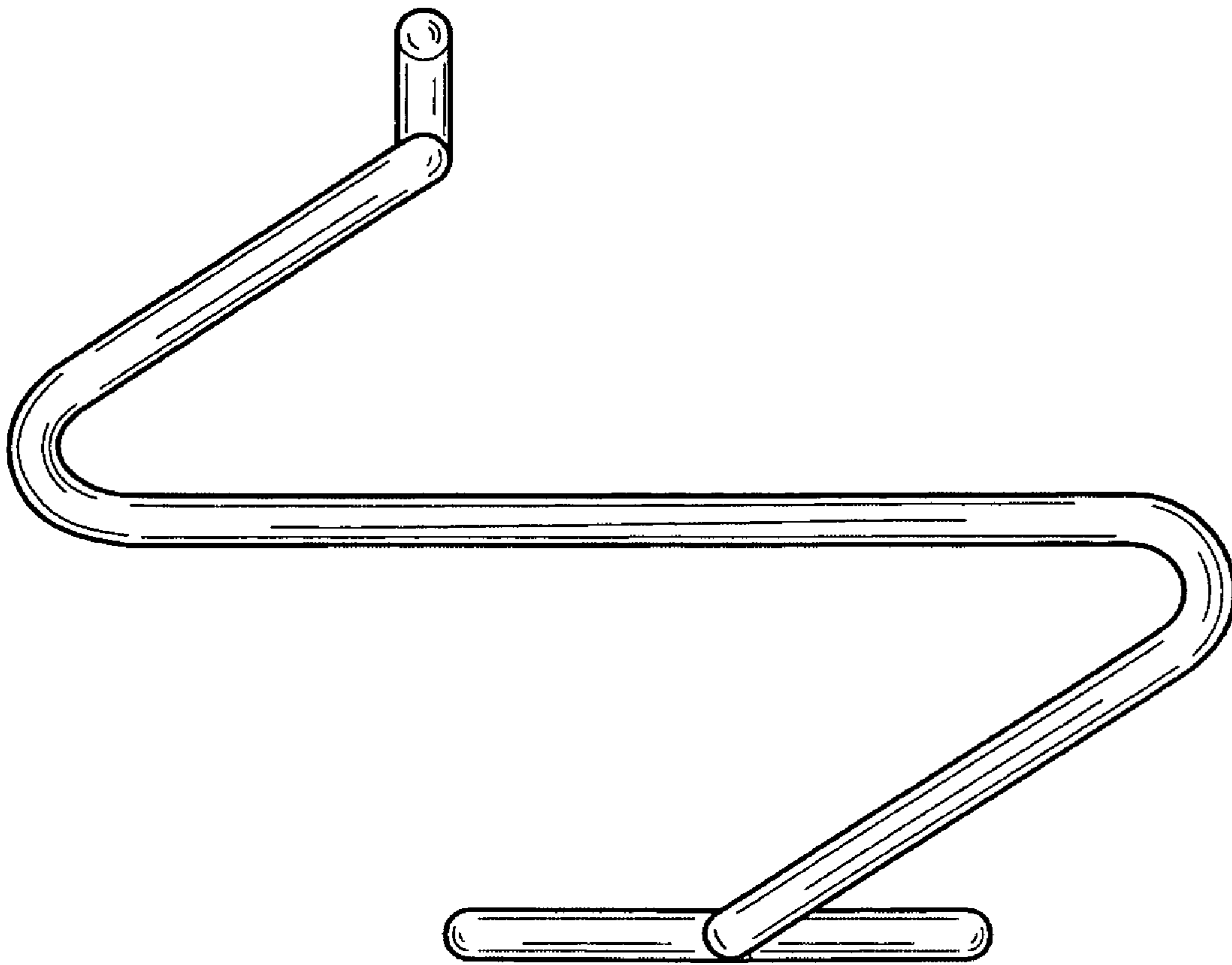
**FIG. 3**



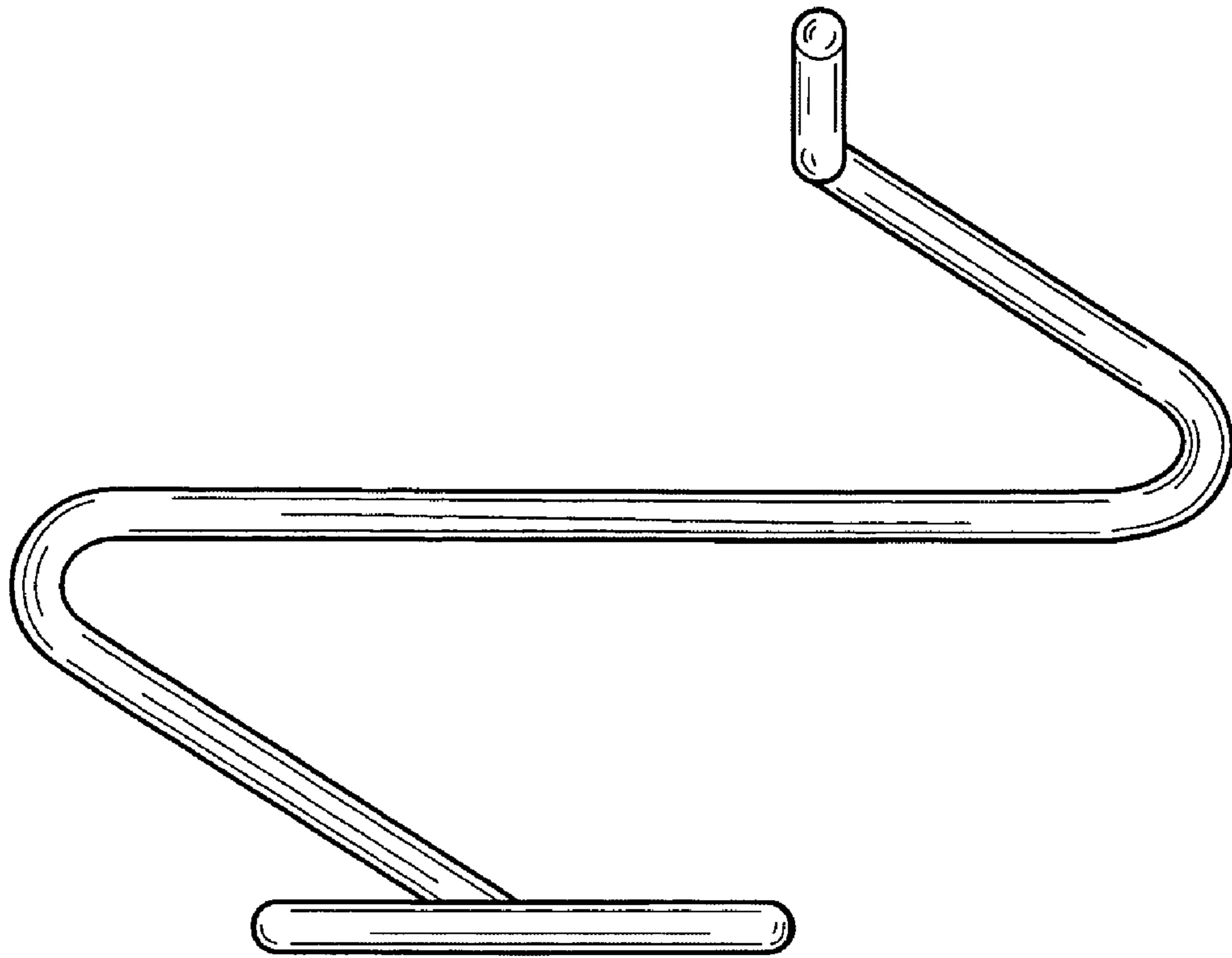
**FIG. 4**



**FIG. 5**



**FIG. 6**



**FIG. 7**