



US00D599569S

(12) **United States Design Patent**  
**Lemon**

(10) **Patent No.:** **US D599,569 S**

(45) **Date of Patent:** **\*\* Sep. 8, 2009**

(54) **MOTORCYCLE SEAT TROUGH**

(76) **Inventor:** **Peter Lemon**, 6245 Viewfield Heights,  
Colorado Springs, CO (US) 80919

(\*\*) **Term:** **14 Years**

(21) **Appl. No.:** **29/302,581**

(22) **Filed:** **Jan. 18, 2008**

(51) **LOC (9) Cl.** ..... **12-11**

(52) **U.S. Cl.** ..... **D6/354**

(58) **Field of Classification Search** ..... D6/354;  
D12/110, 111; 180/219, 220; 297/195.1,  
297/196-215, 215.1, 215.6

See application file for complete search history.

(56) **References Cited**

**U.S. PATENT DOCUMENTS**

D517,332 S \* 3/2006 Manchester et al. .... D6/354  
2005/0236875 A1 \* 10/2005 Milton ..... 297/202

**OTHER PUBLICATIONS**

Custom Chrome 2006 Catalog, 'Hollywood Solo' seat by Corbin,  
shown and described on p. 2.08.\*

\* cited by examiner

*Primary Examiner*—Robin V Webster

*Assistant Examiner*—Linda Brooks

(74) *Attorney, Agent, or Firm*—QuickPatents, Inc.; Kevin Prince

(57) **CLAIM**

I claim the ornamental design for a motorcycle seat trough, as shown and described.

**DESCRIPTION**

FIG. 1 is a perspective view of a motorcycle seat trough, showing my new design;

FIG. 2 is a top plan view thereof;

FIG. 3 is a perspective cut-away view thereof;

FIG. 4 is a cross-sectional view thereof, taken generally along lines 4—4 of FIG. 2; and,

FIG. 5 is a cross-sectional view thereof, taken generally along lines 5—5 of FIG. 2.

The broken lines showing a motorcycle and portions of a motorcycle seat in the figures are included for the purpose of illustrating a motorcycle seat trough in use, and forms no part of the claimed design.

**1 Claim, 3 Drawing Sheets**

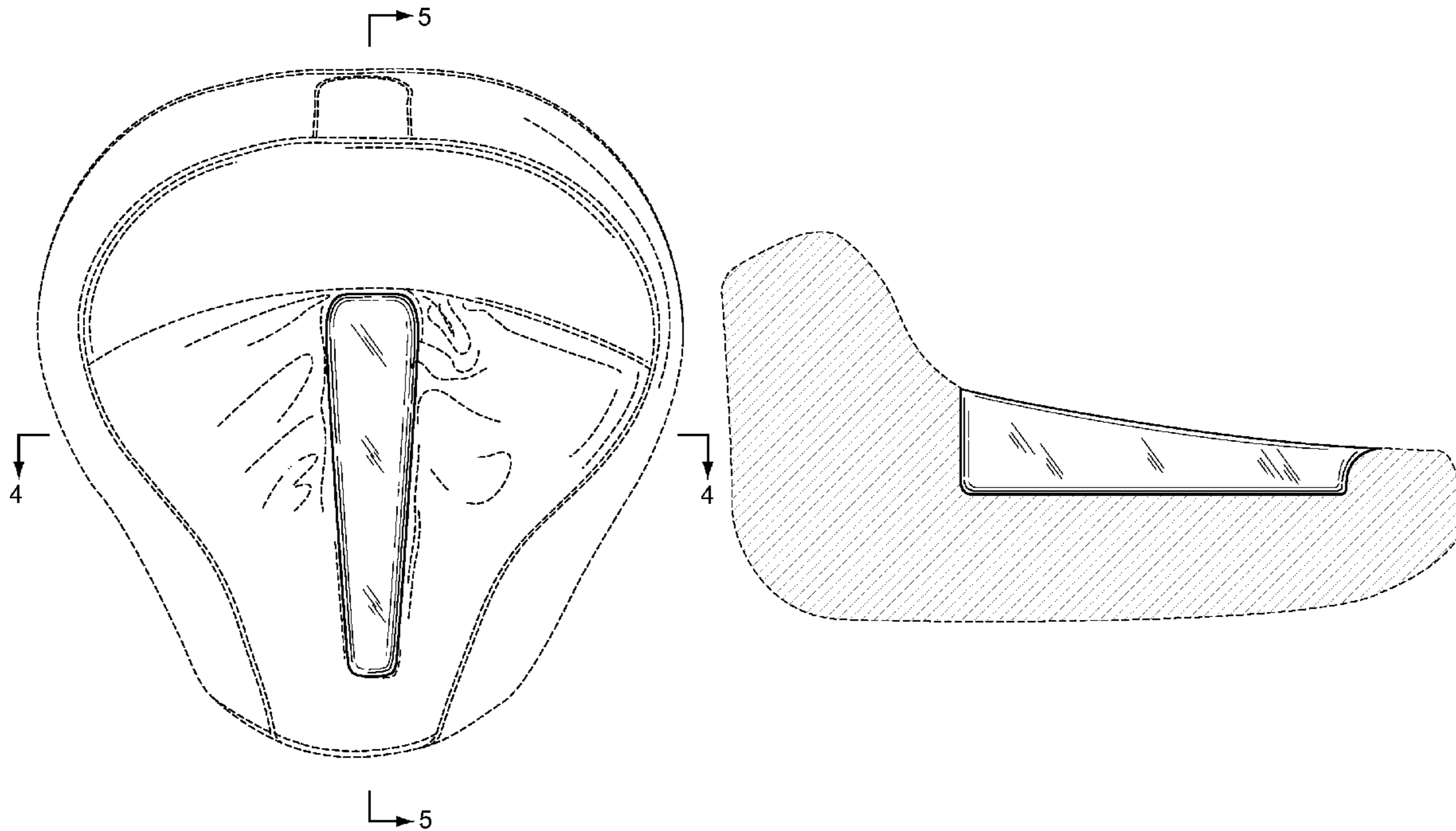

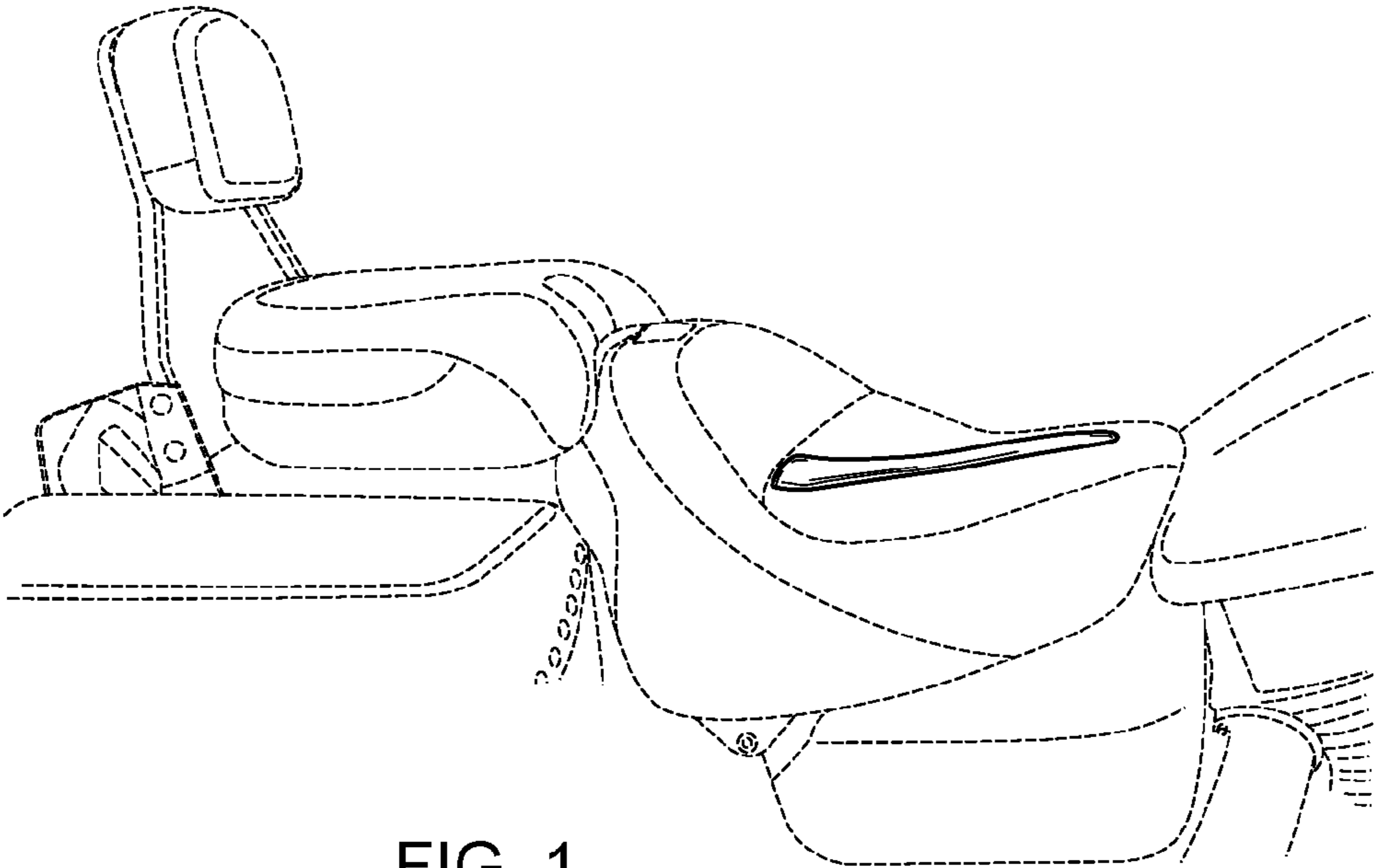

FIG. 1

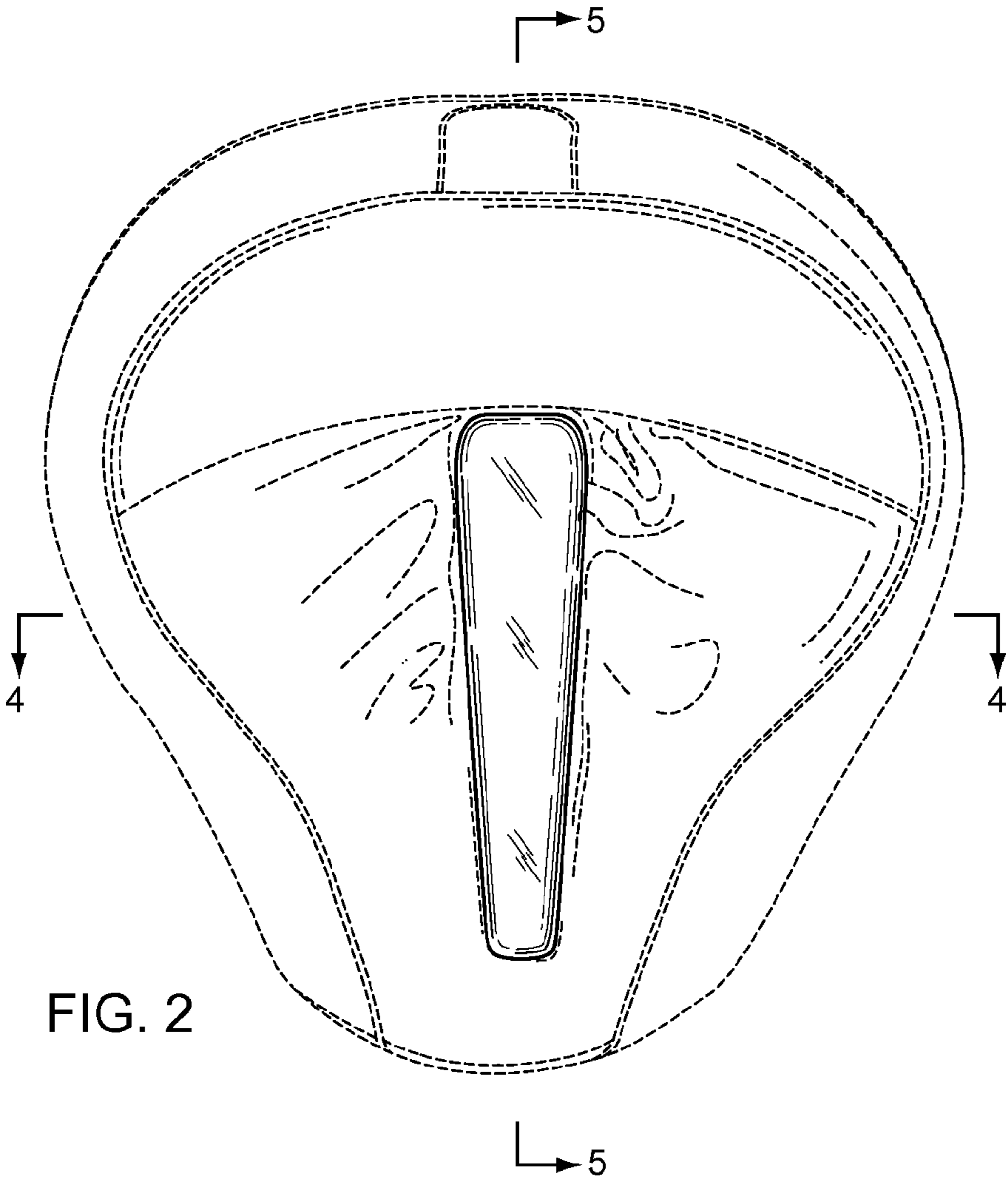

FIG. 2

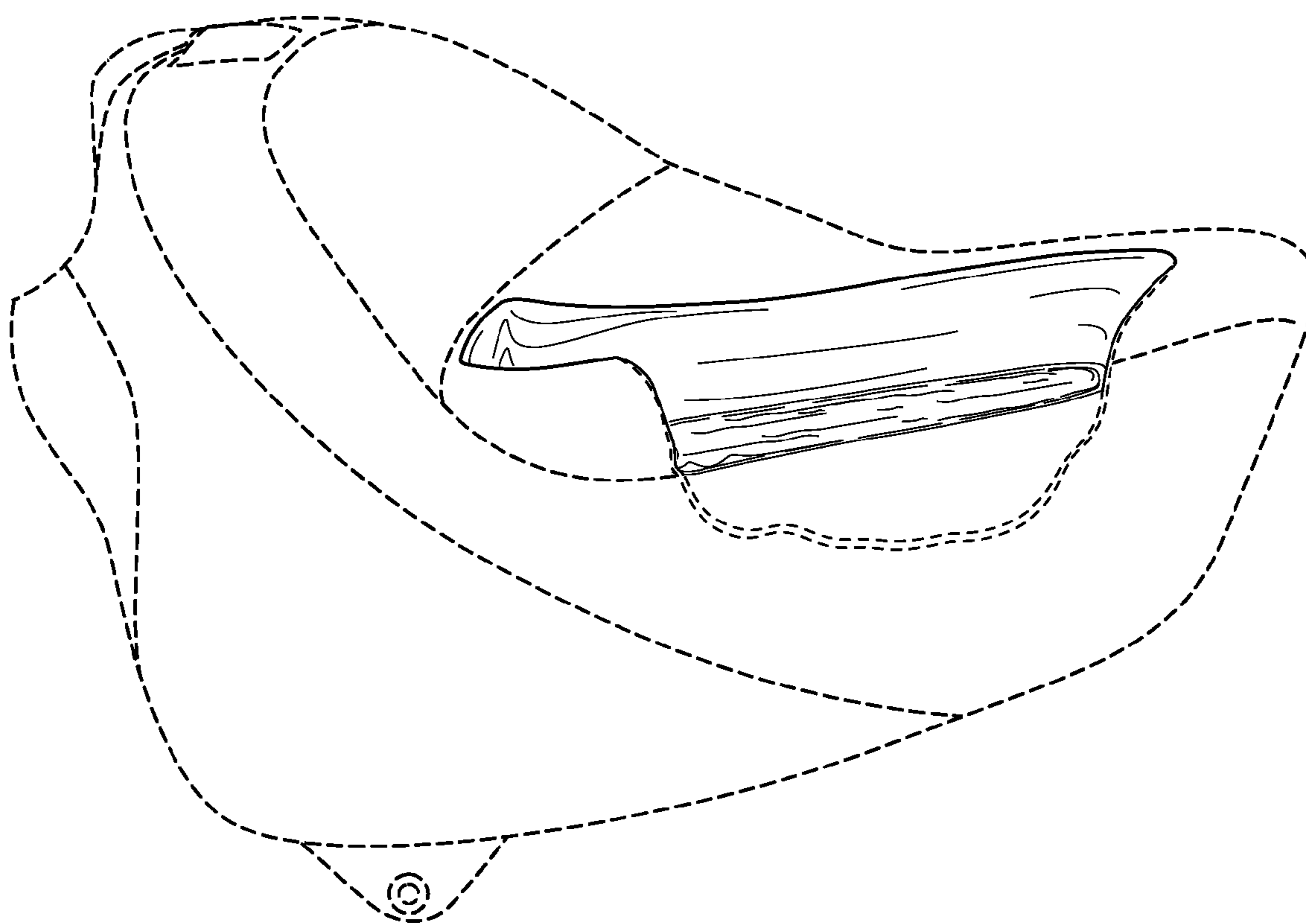

FIG. 3

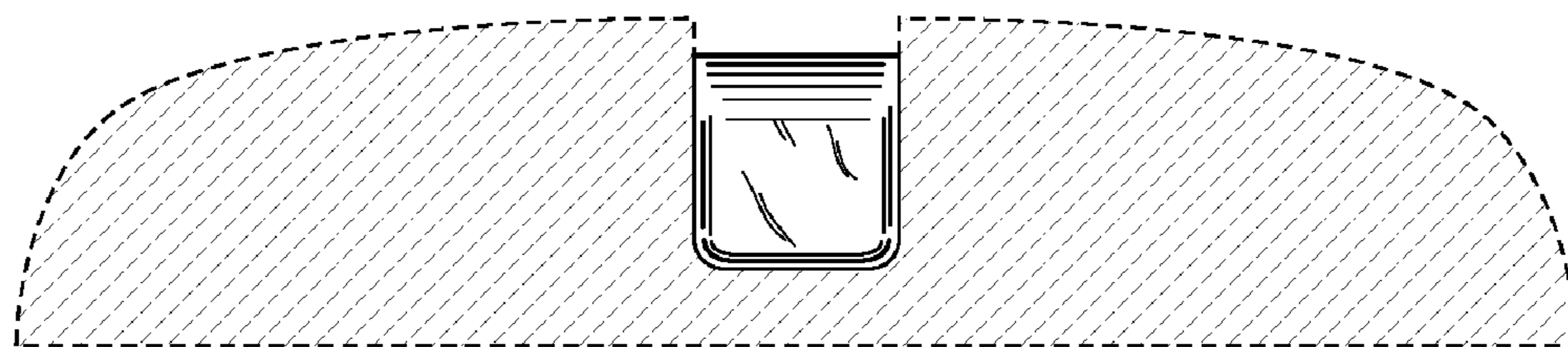

FIG. 4

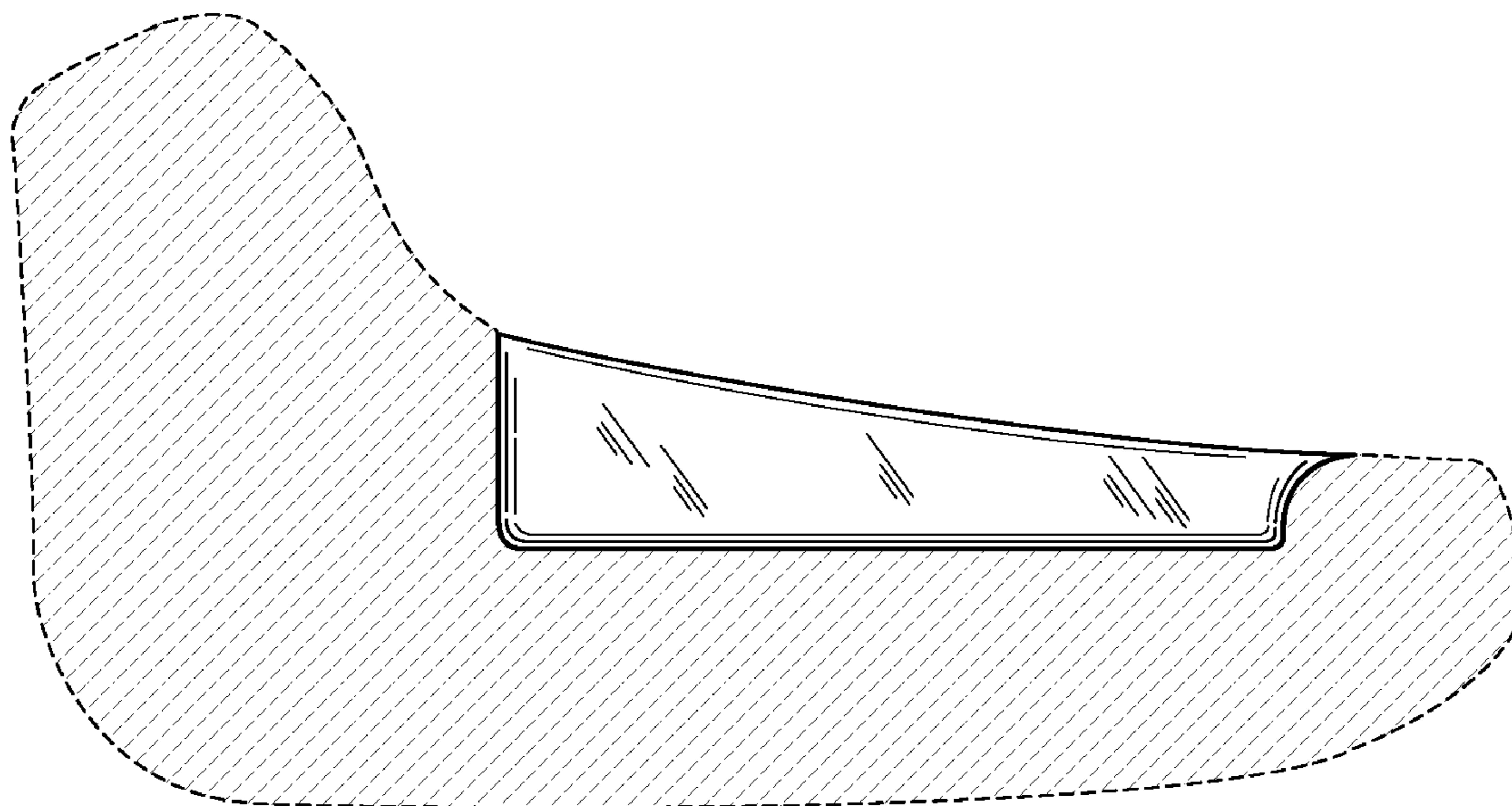

FIG. 5