

US00D599433S

(12) **United States Design Patent**
Zore

(10) **Patent No.:** **US D599,433 S**

(45) **Date of Patent:** **** Sep. 1, 2009**

(54) **NOZZLE**

(75) Inventor: **William Francis Zore**, Friedens, PA
(US)

(73) Assignee: **Robert Bosch GmbH**, Stuttgart (DE)

(**) Term: **14 Years**

(21) Appl. No.: **29/326,938**

(22) Filed: **Oct. 28, 2008**

(51) **LOC (9) Cl.** **23-01**

(52) **U.S. Cl.** **D23/223**

(58) **Field of Classification Search** D23/213,
D23/223, 226; 239/525–526, 532

See application file for complete search history.

(56) **References Cited**

U.S. PATENT DOCUMENTS

3,207,444	A	9/1965	Kelly et al.
4,470,549	A	9/1984	McMillan et al.
4,899,940	A	2/1990	Leaver

(Continued)

OTHER PUBLICATIONS

www.target.com website page; Published at least as early as Jun. 6, 2008; One page.

www.doitbest.com website page; Published at least as early as Jun. 6, 2008; One page.

Primary Examiner—Robin V Webster

(74) *Attorney, Agent, or Firm*—Maginot, Moore & Beck

(57) **CLAIM**

The ornamental design for a nozzle, as shown and described.

DESCRIPTION

FIG. 1 is a perspective view a nozzle showing my new design;

FIG. 2 is a left side elevational view showing the design for the nozzle of FIG. 1;

FIG. 3 is a right side elevational view showing the design for the nozzle of FIG. 1;

FIG. 4 is a front elevational view showing the design for the nozzle of FIG. 1;

FIG. 5 is a rear elevational view showing the design for the nozzle of FIG. 1;

FIG. 6 is a top elevational view showing the design for the nozzle of FIG. 1; and,

FIG. 7 is a bottom elevational view showing the design for the nozzle of FIG. 1.

The broken lines showing of portions of the nozzle is included for illustrative purposes only and forms no part of the claimed design.

1 Claim, 5 Drawing Sheets

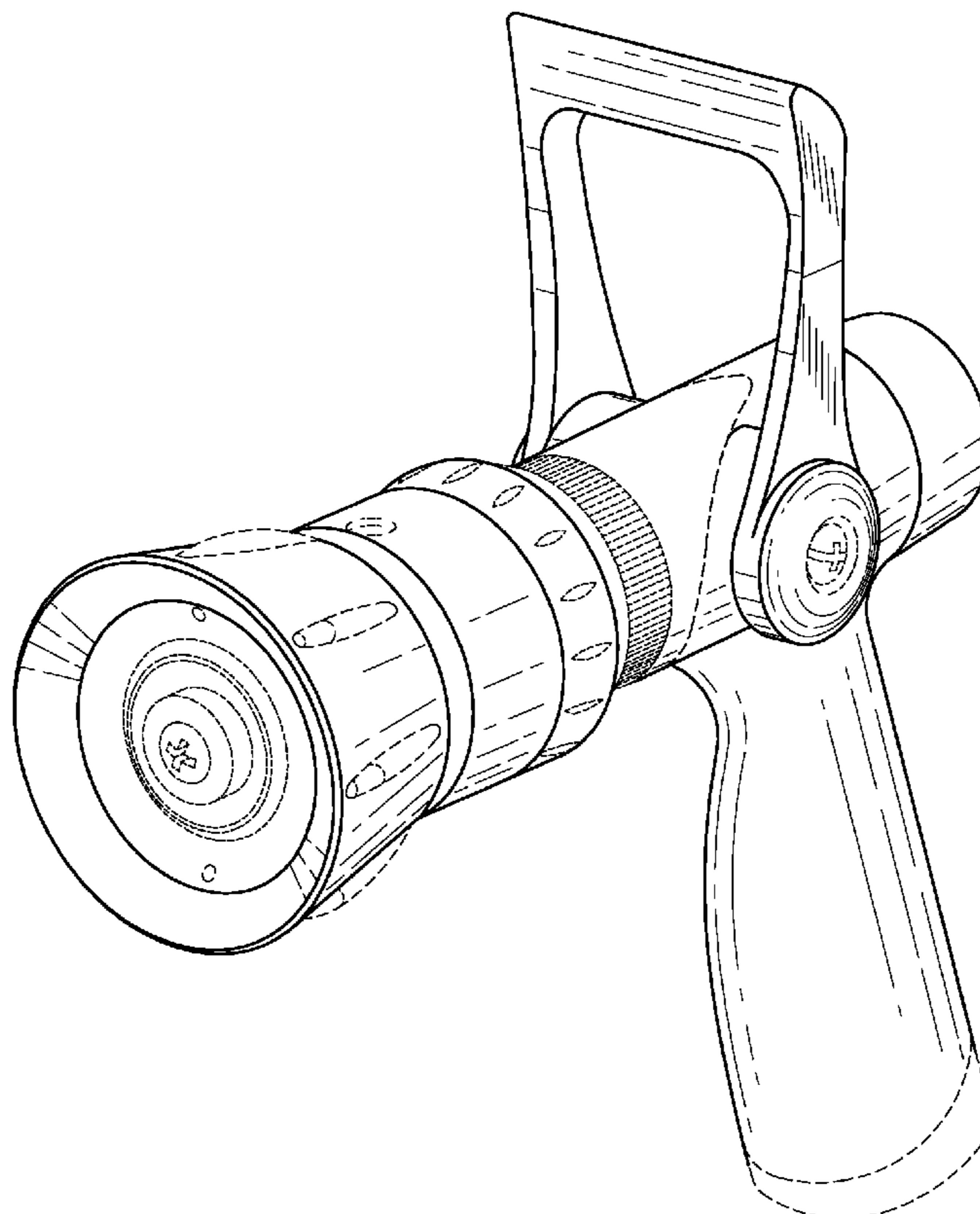

US D599,433 S

Page 2

U.S. PATENT DOCUMENTS

4,903,897 A	2/1990	Hayes	D415,249 S	10/1999	Wang	
D325,620 S	4/1992	Heren	D415,557 S	10/1999	Kuo	
D338,706 S	8/1993	Wang	D427,660 S	7/2000	Casica et al.	
D340,762 S	10/1993	Wang	D431,069 S	9/2000	Heren	
D355,952 S	2/1995	Wang	D432,628 S	10/2000	Chao	
D355,953 S	2/1995	Wang	D433,099 S	10/2000	Chao	
D359,101 S	6/1995	Kuo	D437,391 S	2/2001	Chao	
D372,297 S	7/1996	Wang	D445,873 S	7/2001	Wang	
D373,814 S	9/1996	Wang	D446,282 S	8/2001	Wang	
D384,398 S	9/1997	Wang	D447,790 S	9/2001	Heren et al.	
D385,948 S	11/1997	Guo	D451,982 S	12/2001	Chao	
D390,633 S	2/1998	Guo	D459,435 S	6/2002	Fauquet	
D392,719 S	3/1998	Guo	D461,225 S	8/2002	Chen	
D394,305 S	5/1998	Kuo	D472,605 S	4/2003	Nien	
D407,140 S	3/1999	Heren	D479,302 S	9/2003	Chen	
D408,068 S	4/1999	Hui-Chen	D492,979 S	7/2004	Chen	
D408,496 S	4/1999	Wang	D496,430 S	9/2004	Kuo	
D408,497 S	4/1999	Wang	D515,662 S	2/2006	Chen	
D409,717 S	5/1999	Heren et al.	D557,378 S	12/2007	Chen	
D409,720 S	5/1999	Guo	D557,379 S	12/2007	Chen	
D410,730 S	6/1999	Wang	7,328,860 B1 *	2/2008	Chen et al.	239/581.1
D410,994 S	6/1999	Hui-Chen	D565,700 S	4/2008	Chen	
D412,356 S	7/1999	Hui-Chen	7,434,751 B1 *	10/2008	Chen	239/526

* cited by examiner

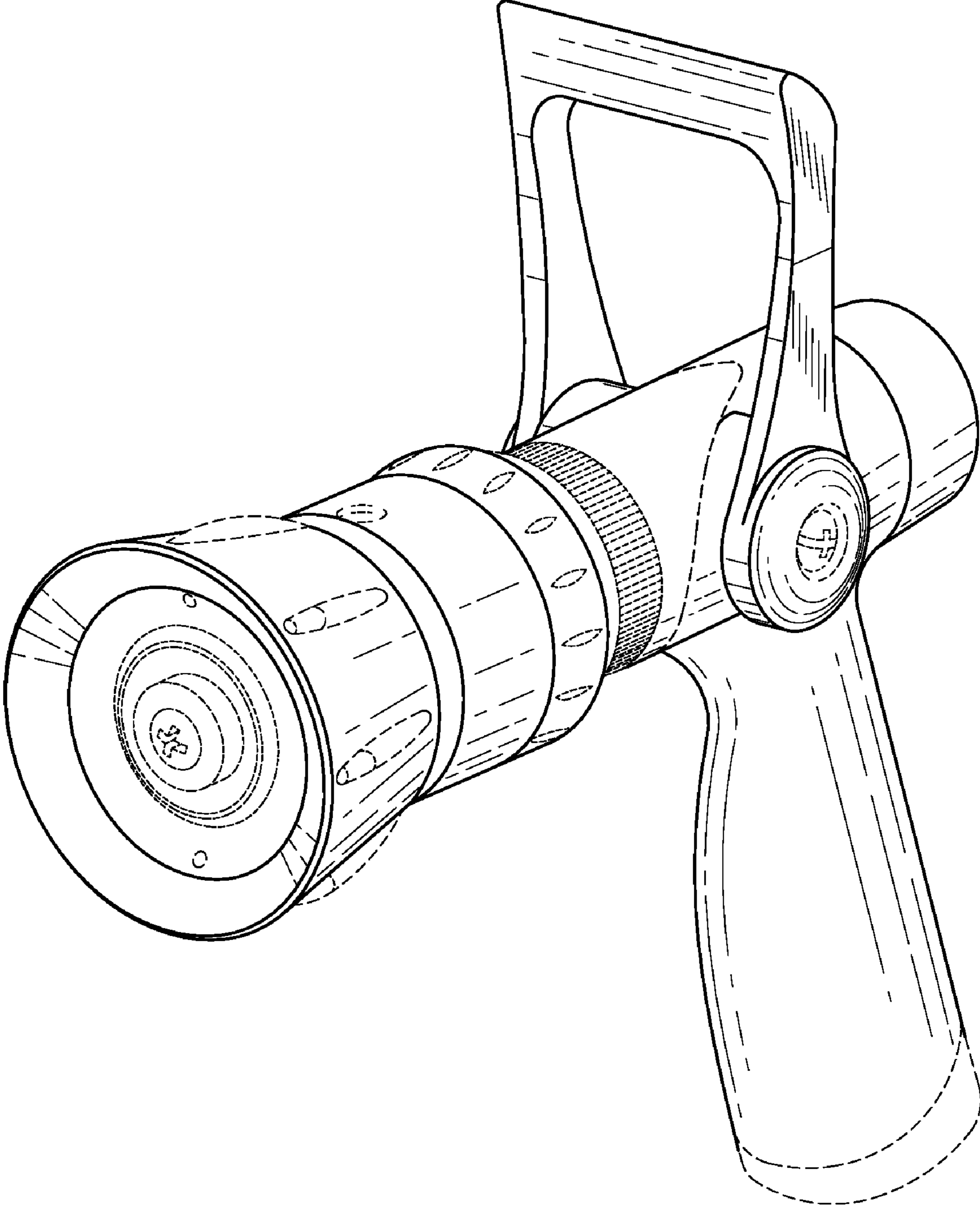

Fig. 1

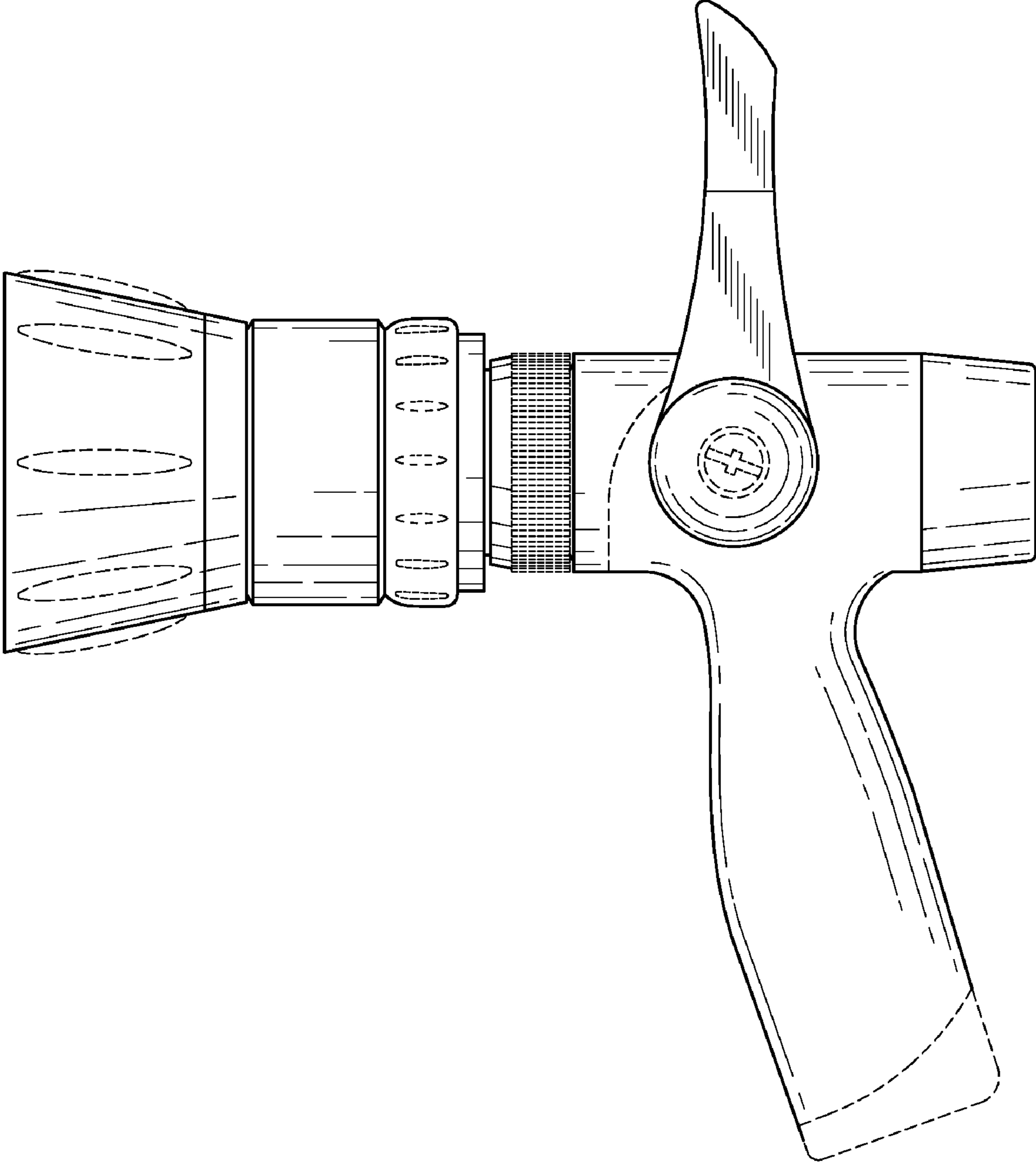

Fig. 2

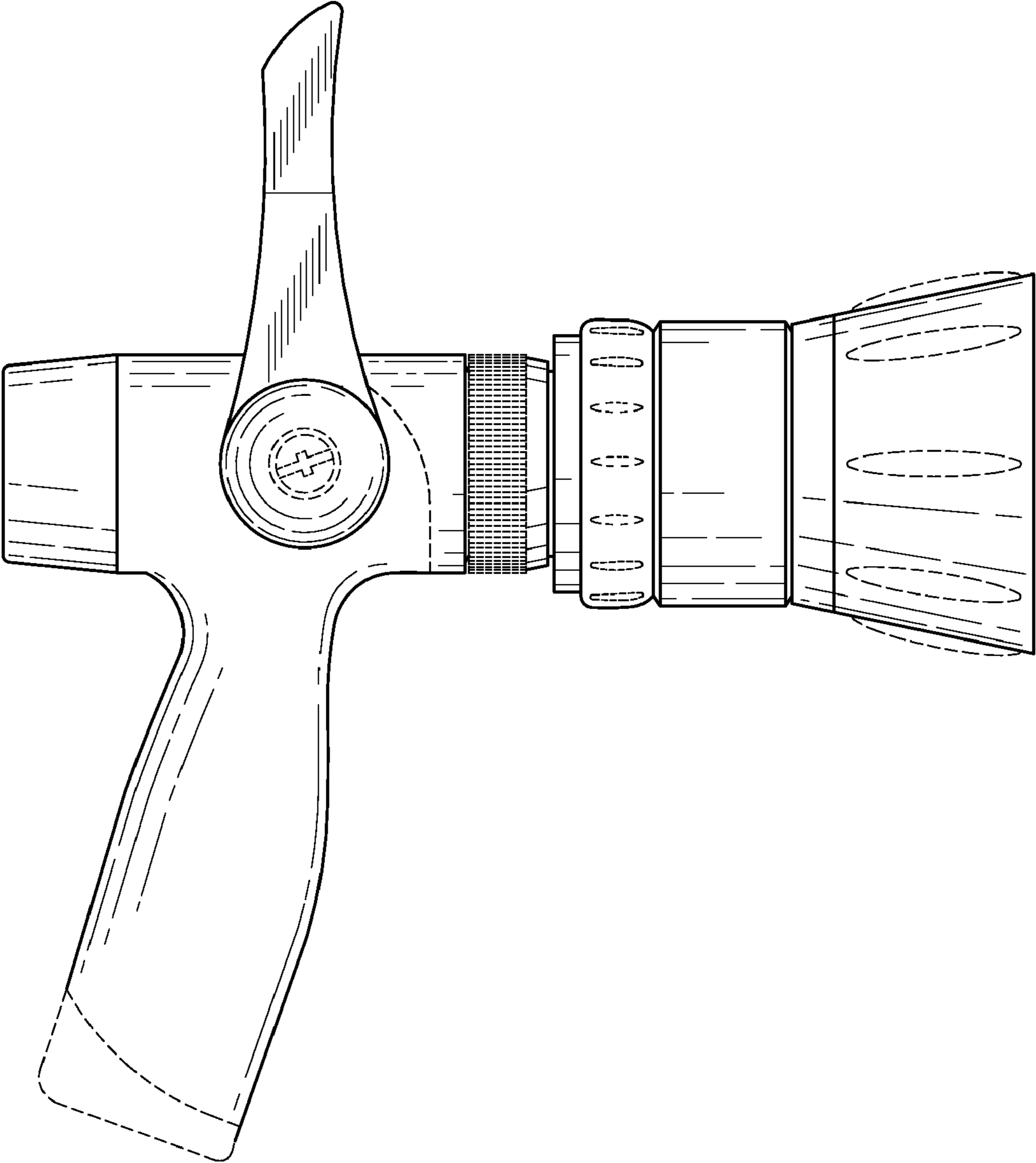

Fig. 3

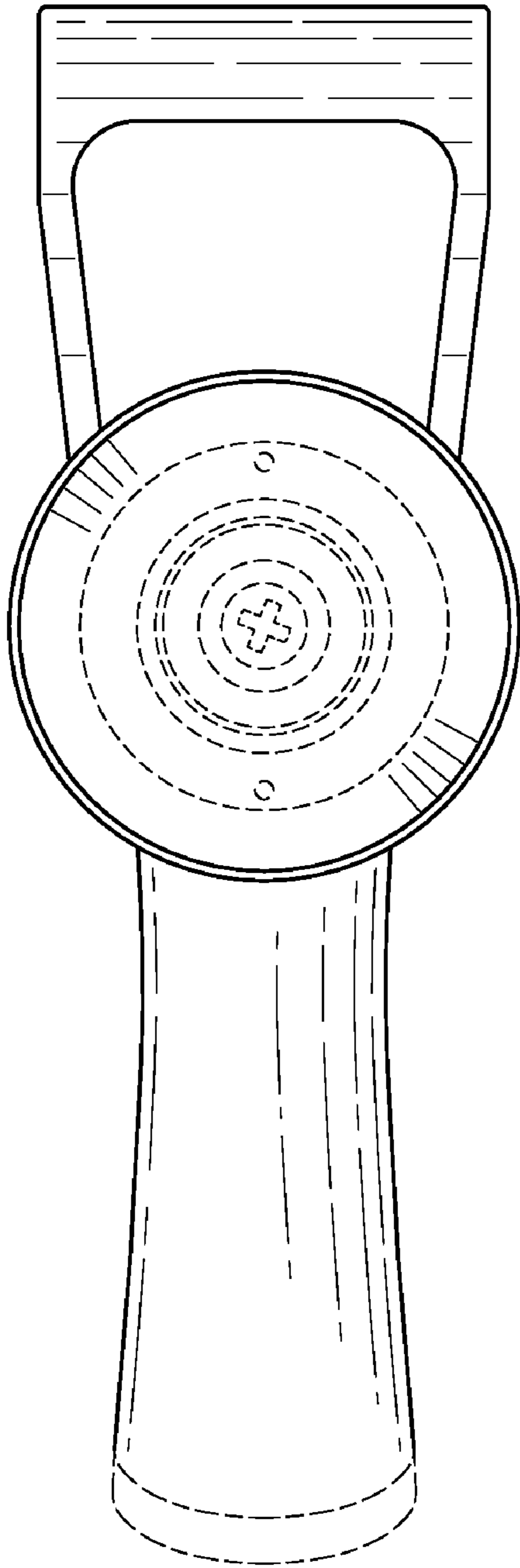

Fig. 4

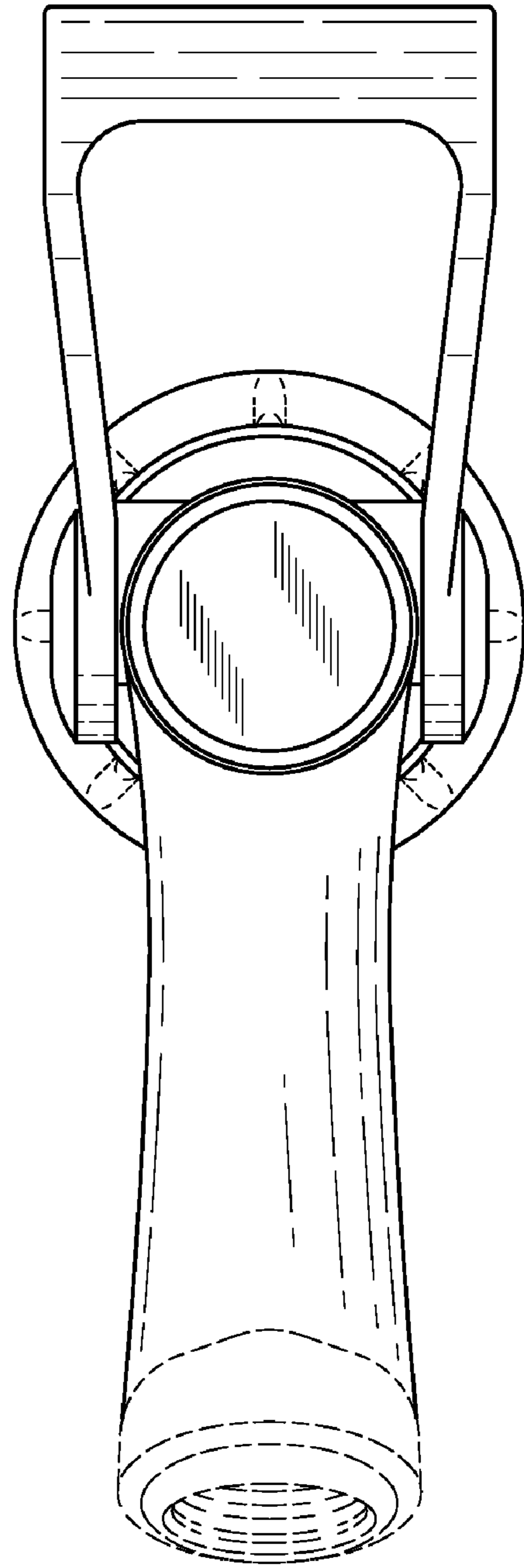

Fig. 5

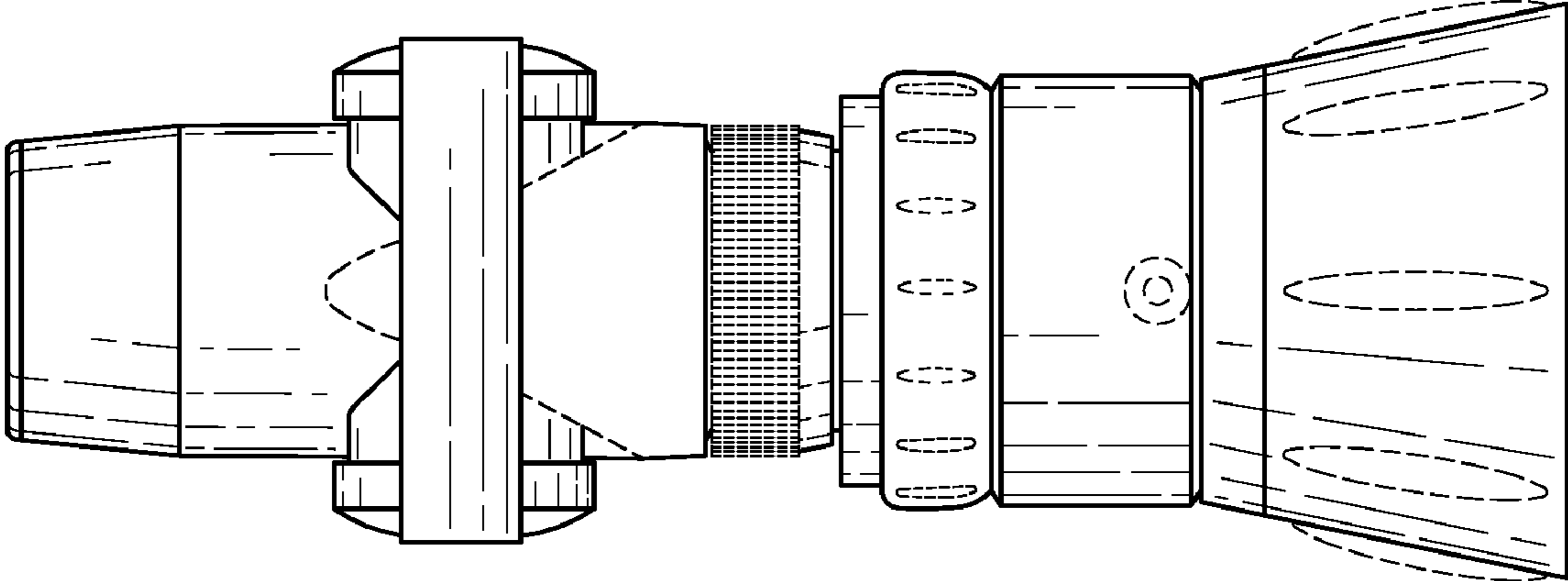

Fig. 6

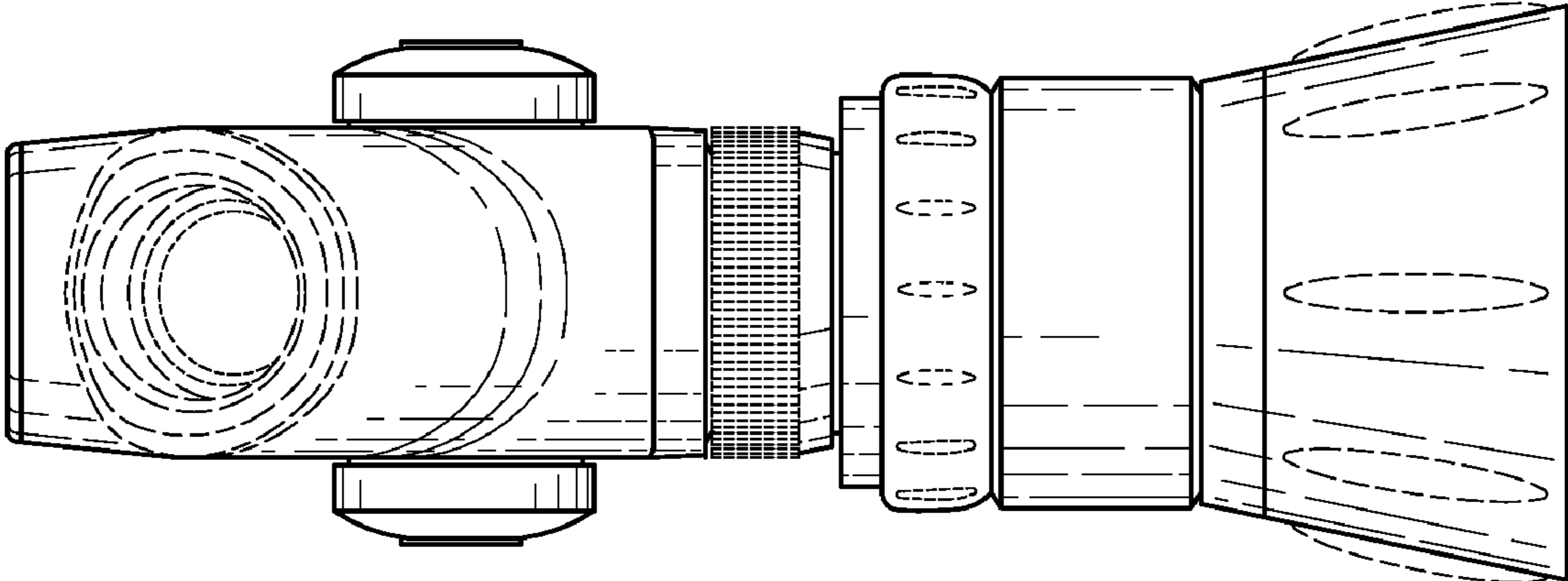

Fig. 7