

US00D599310S

(12) **United States Design Patent**
Correll et al.

(10) **Patent No.:** **US D599,310 S**
(45) **Date of Patent:** **** Sep. 1, 2009**

(54) **ELECTRICAL TERMINAL HOUSING**

(75) Inventors: **Michael Anthony Correll**, Hershey, PA (US); **Gerwin Müller**, Kiel (DE)

(73) Assignee: **Phoenix Contact Development & Manufacturing, Inc.**, Middletown, PA (US)

(**) Term: **14 Years**

(21) Appl. No.: **29/336,288**

(22) Filed: **Apr. 30, 2009**

Related U.S. Application Data

(62) Division of application No. 29/282,564, filed on Jul. 24, 2007, now Pat. No. Des. 591,699.

(51) **LOC (9) Cl.** **13-99**

(52) **U.S. Cl.** **D13/184**

(58) **Field of Classification Search** D13/184, D13/110, 152, 177, 103, 107, 112, 122, 124, D13/199; D10/80, 103, 104; D14/100, 102, D14/308, 314, 347, 348, 349, 353, 354, 355, D14/357, 358, 433, 440, 441, 188, 265, 299; 174/50, 35 R, 52.1; 220/3.8, 4.02; 361/600; D3/273

See application file for complete search history.

(56) **References Cited**

U.S. PATENT DOCUMENTS

D198,132 S * 5/1964 Radtke et al. D13/139.1
D259,418 S 6/1981 Allen

OTHER PUBLICATIONS

Phoenix Contact, Inc., Signal Converters Interface, product catalog, 2007, 465 pages, entire catalog relevant but pp. 38, 42, 43, 56-70,

80-86, 94-115, 118, 119, 150, 155, 156, 159, 171-199, 208-235, 244-247, 316-319, 364,365, 392, 393, 408-411, 434-436 deemed particularly relevant.

Phoenix Contact, Inc., Pluggable four-level spring-cage terminal block for mounting on NS 35, online catalog page available at <http://www.phoenixcon.com>, part No. 3041985, 1 page.

* cited by examiner

Primary Examiner—T. Chase Nelson

Assistant Examiner—Ania K Dworzecka

(74) *Attorney, Agent, or Firm*—Hooker & Habib, P.C.

(57) **CLAIM**

The ornamental design for an electrical terminal housing, as shown and described.

DESCRIPTION

FIG. 1 is a front right perspective view of an electrical terminal housing showing our new design;

FIG. 2 is a rear and left perspective view of the electrical terminal housing of FIG. 1;

FIG. 3 is a right side elevation view of the electrical terminal housing of FIG. 1;

FIG. 4 is a left side elevation view of the electrical terminal housing of FIG. 1;

FIG. 5 is a rear elevation view of the electrical terminal housing of FIG. 1 taken along line 5—5 of FIG. 4;

FIG. 6 is a top plan view of the electrical terminal housing of FIG. 1 taken along line 6—6 of FIG. 7;

FIG. 7 is a front elevation view of the electrical terminal housing of FIG. 1 taken along line 7—7 of FIG. 4; and,

FIG. 8 is a bottom plan view of the electrical terminal housing of FIG. 1.

The broken lines in the drawings are for illustrative purposes only and form no part of the claimed design.

1 Claim, 6 Drawing Sheets

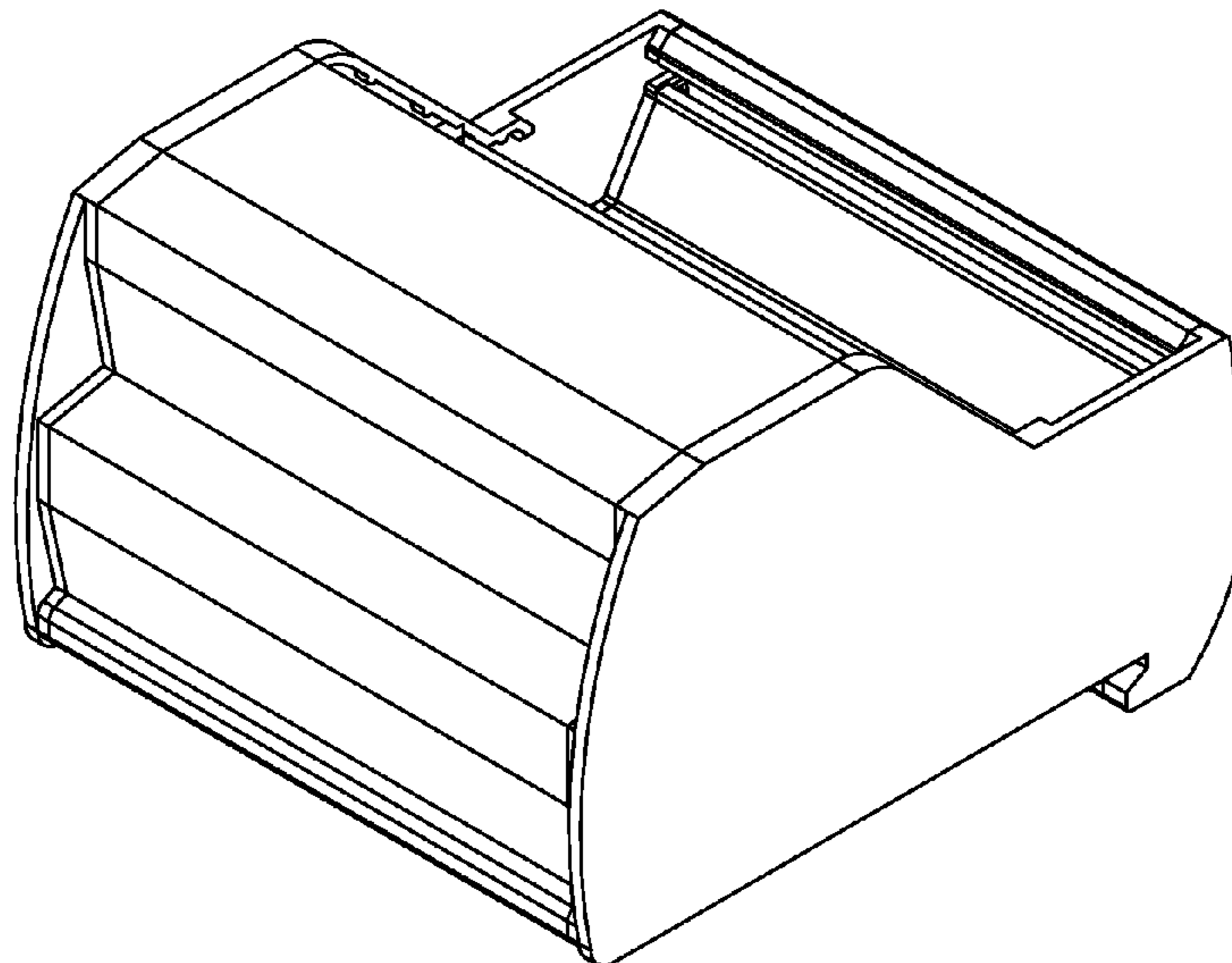

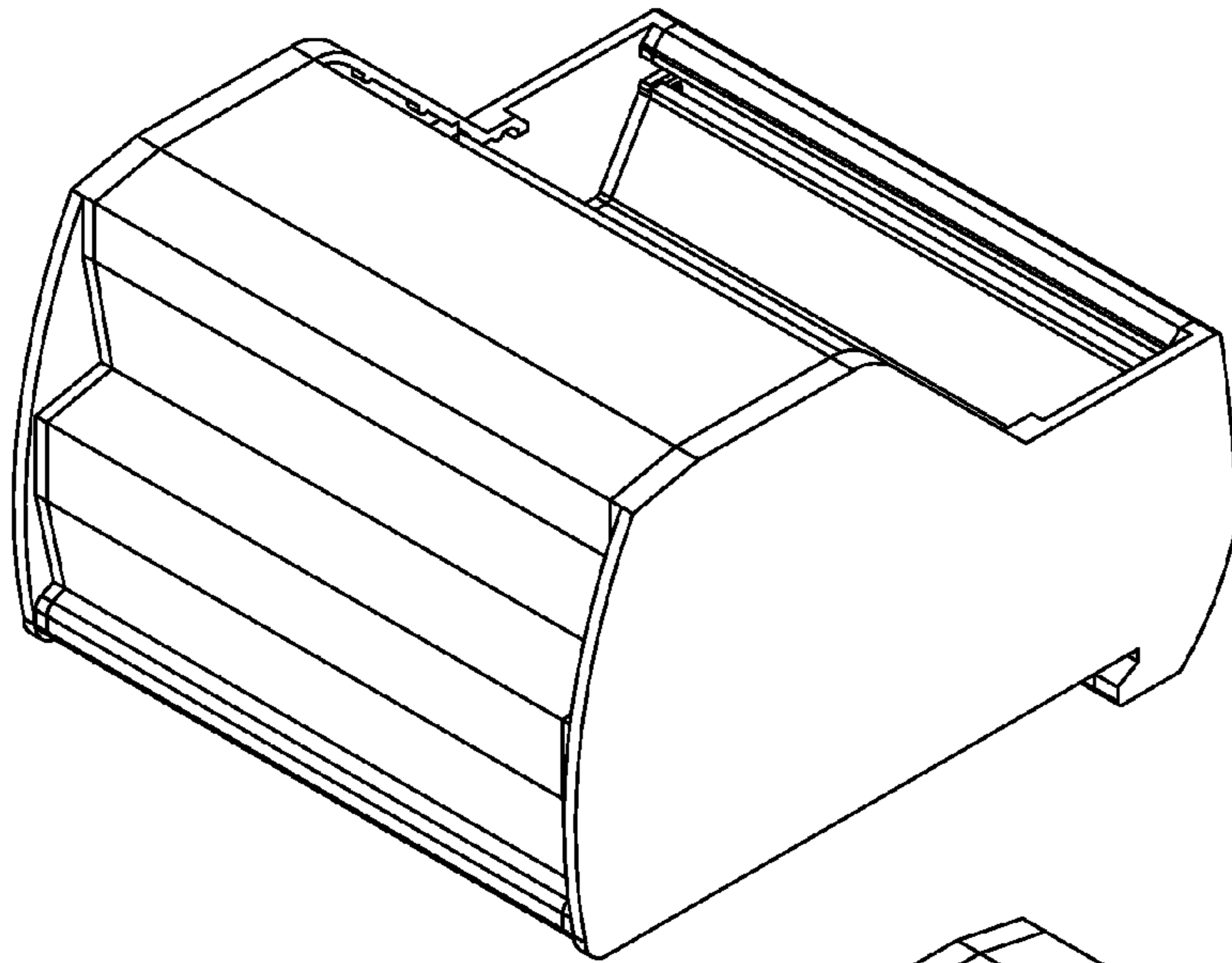

FIG. 1

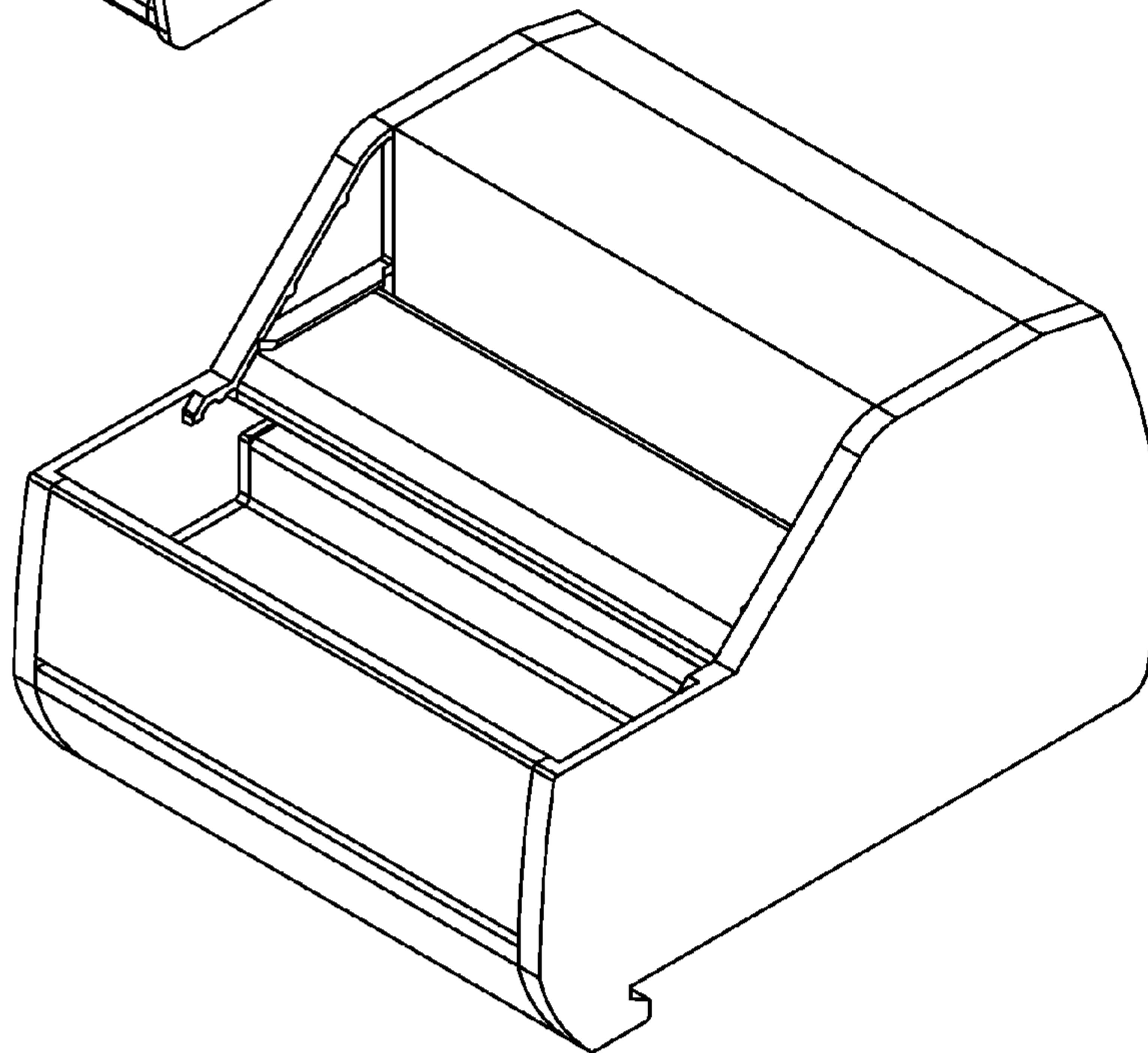

FIG. 2

FIG. 3

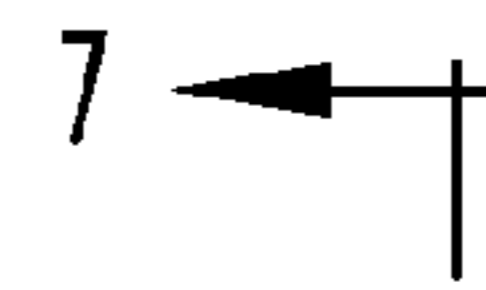
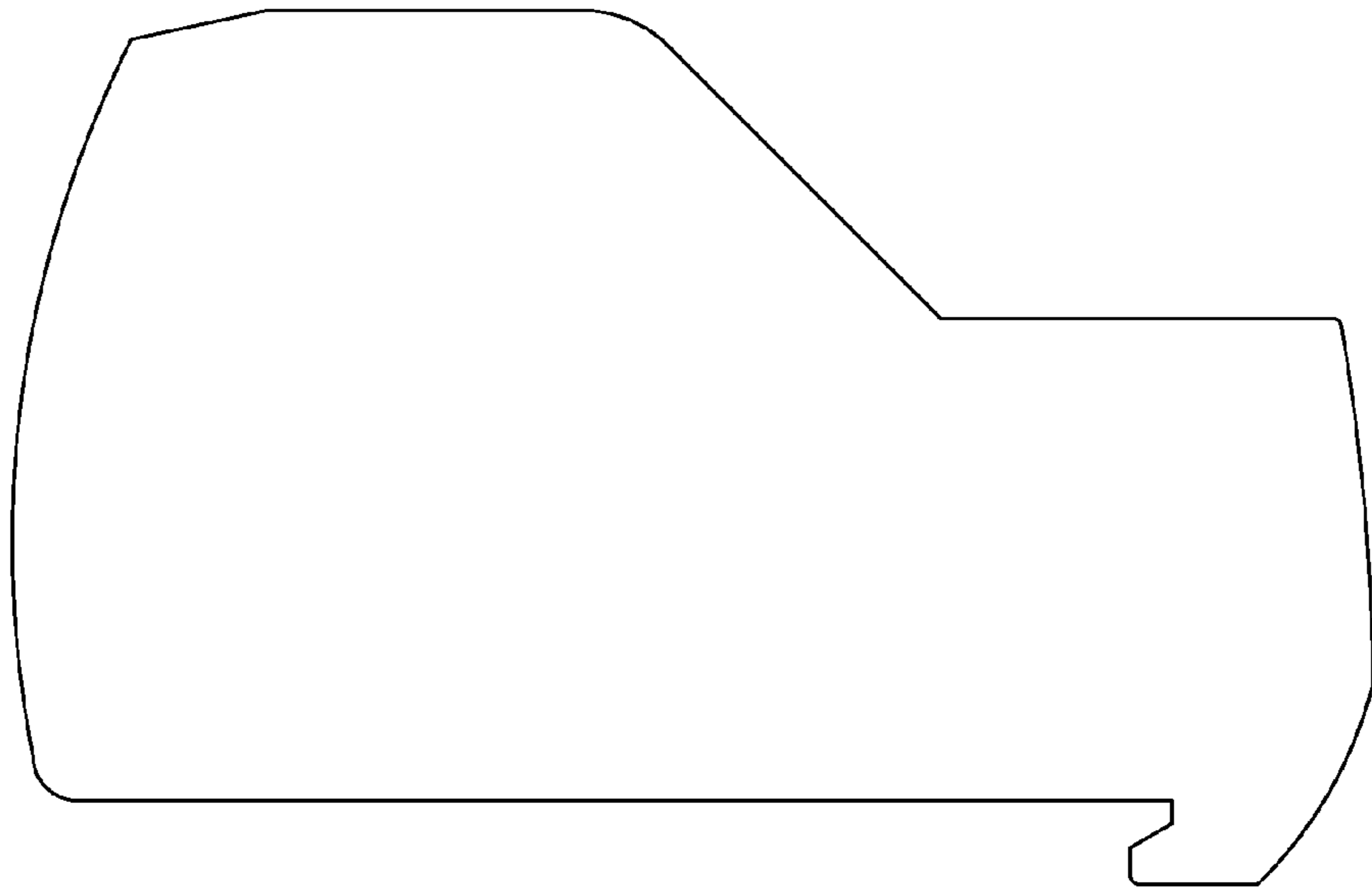
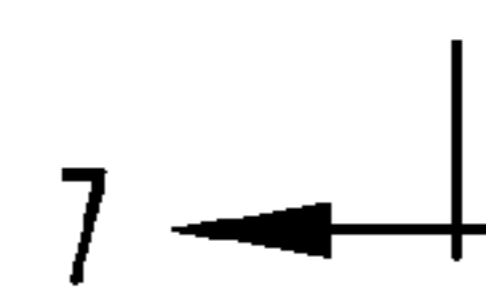
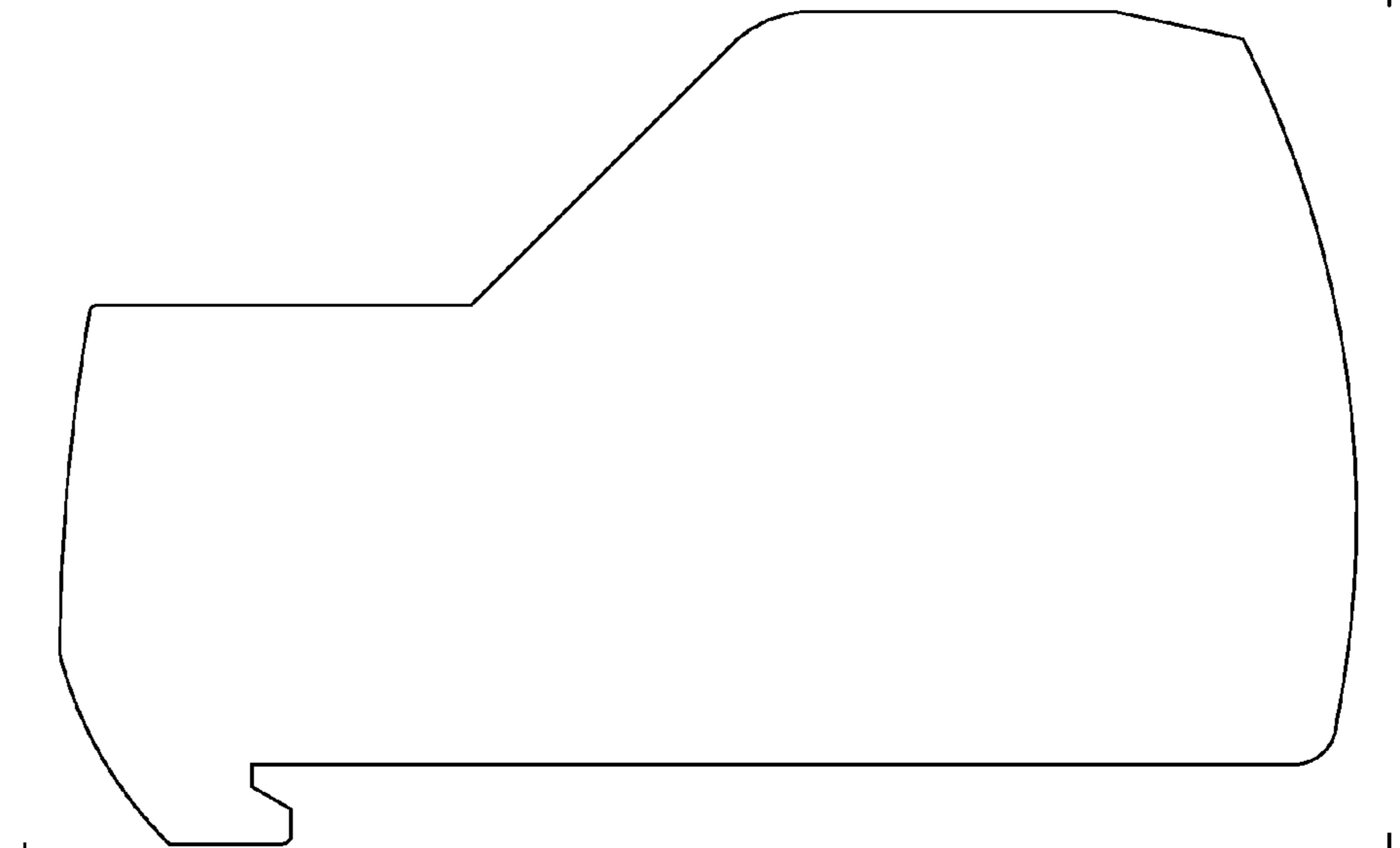

FIG. 4



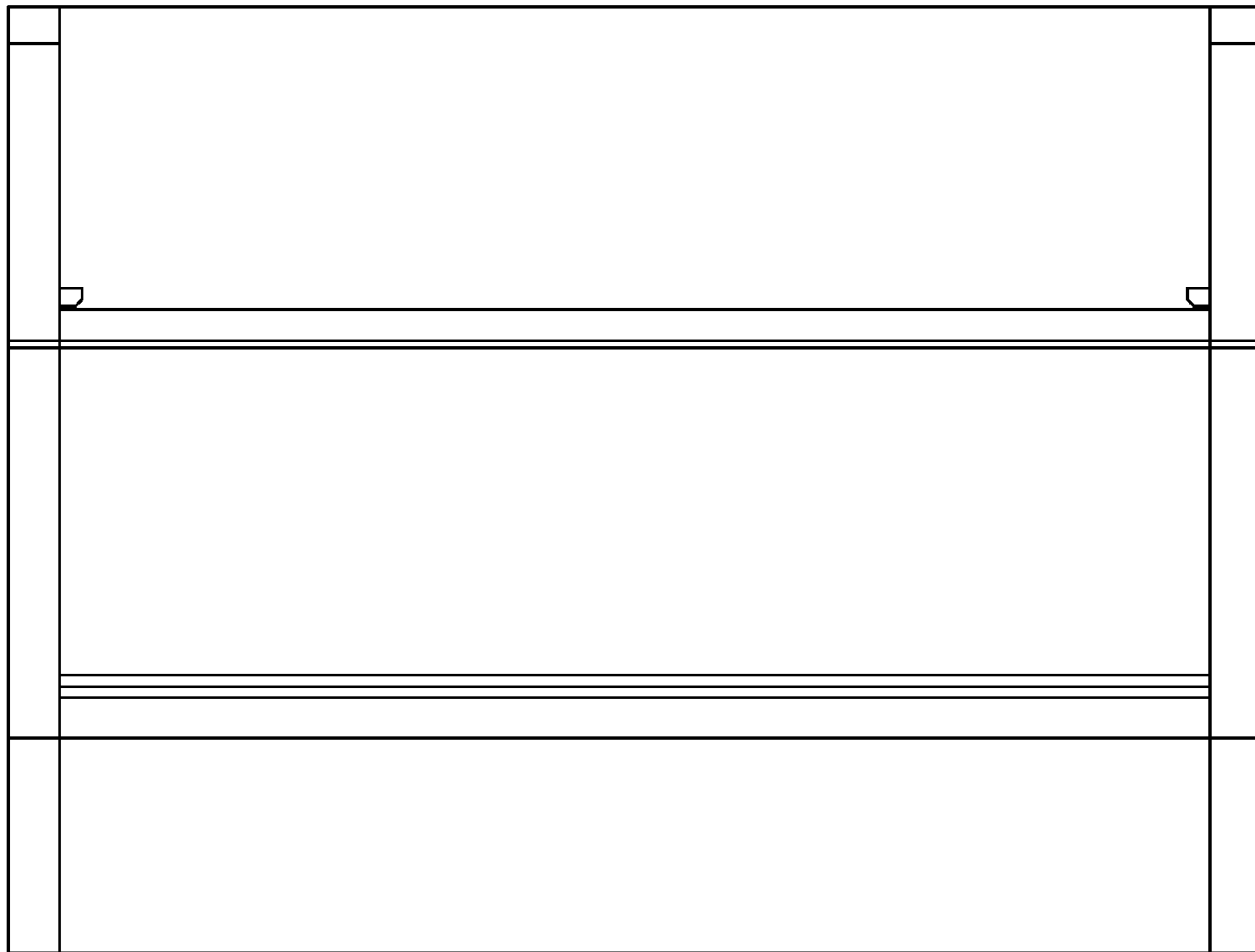

FIG. 5

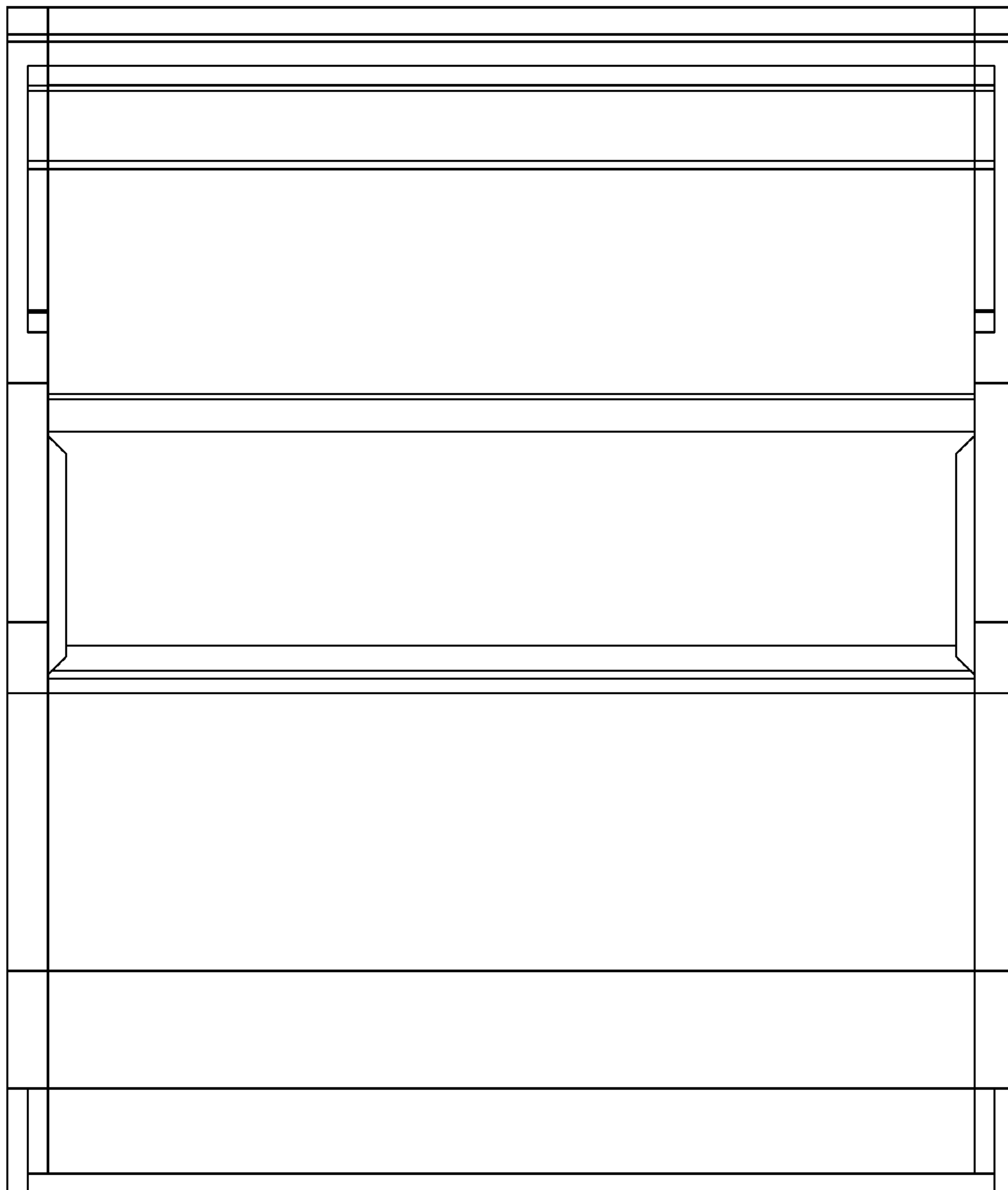

FIG. 6

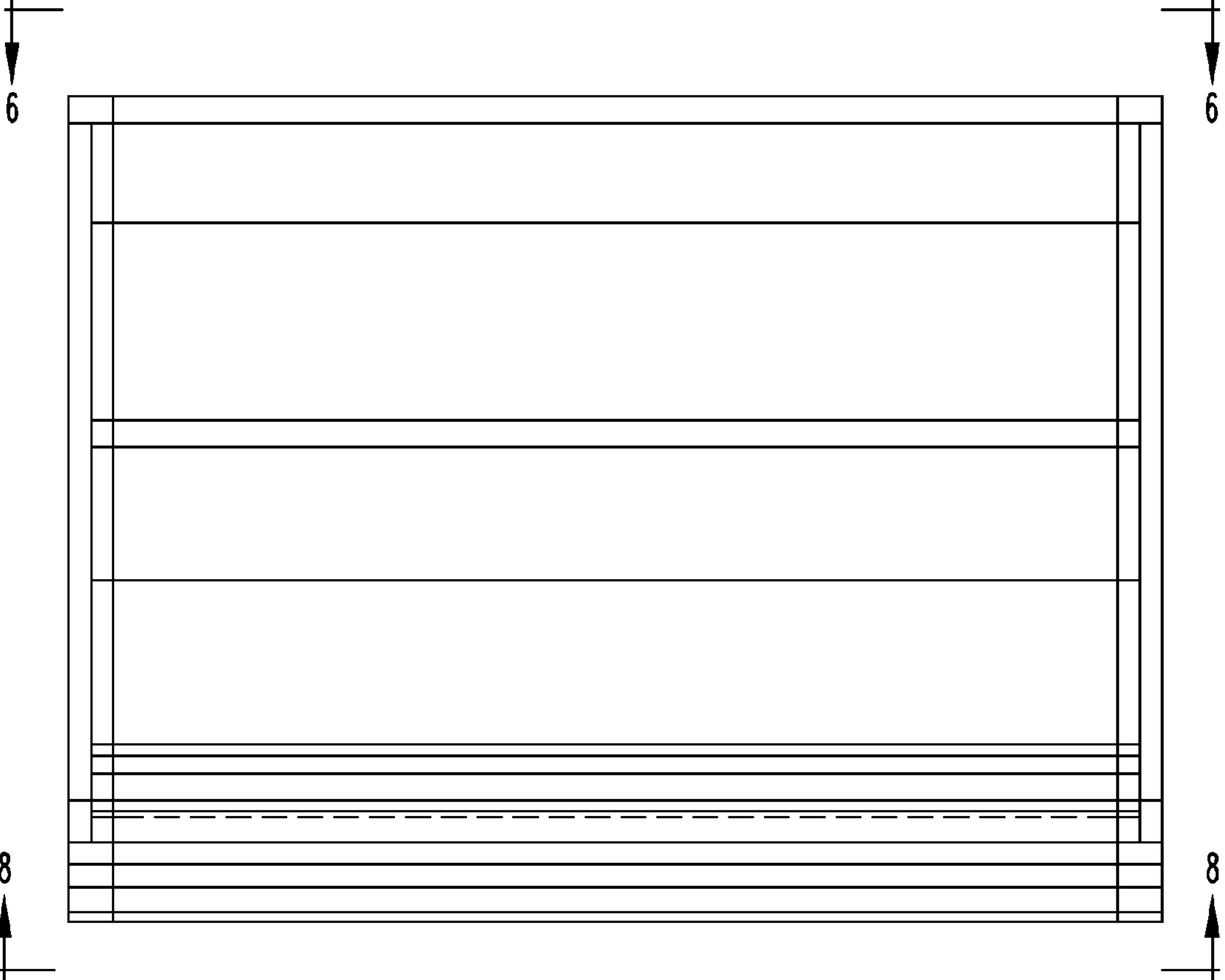

FIG. 7

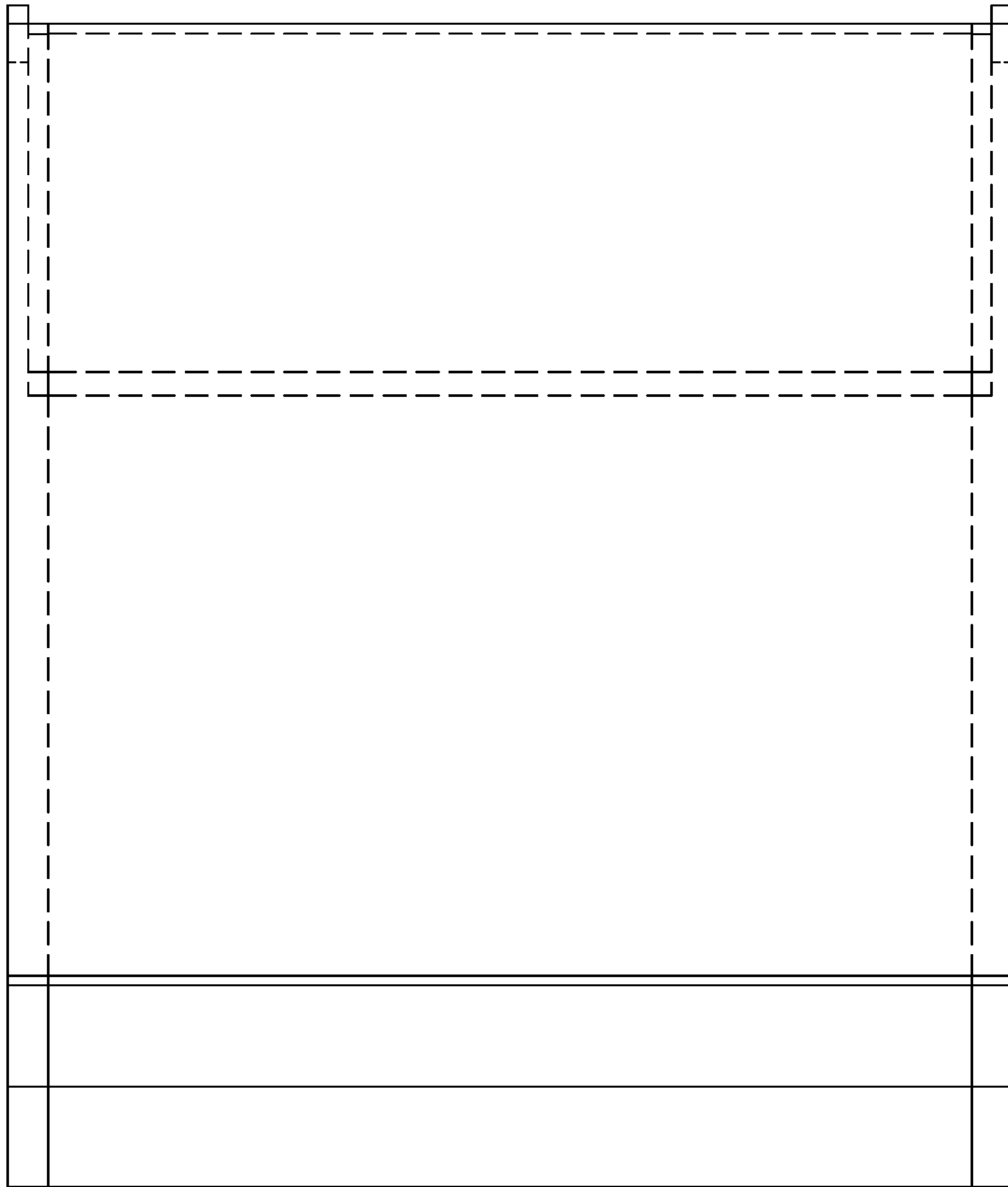

FIG. 8