



US00D599262S

(12) **United States Design Patent**
Reed et al.

(10) **Patent No.:** **US D599,262 S**
(45) **Date of Patent:** **** Sep. 1, 2009**

(54) **LEFT HAND HANDLEBAR CONTROLLER
FOR AN ALL TERRAIN VEHICLE**

2007/0051552 A1* 3/2007 Reed 180/333

(75) Inventors: **Mark D. Reed**, Springfield, IL (US); **Al Cable**, Springfield, IL (US)

(73) Assignee: **Honeywell International Inc.**,
Morristown, NJ (US)

(**) Term: **14 Years**

(21) Appl. No.: **29/293,434**

(22) Filed: **Nov. 21, 2007**

(51) **LOC (9) Cl.** **12-11**

(52) **U.S. Cl.** **D12/174**

(58) **Field of Classification Search** D12/114,
D12/122, 124, 174, 177-179, 110-112, 85-87,
D12/107; D8/303; 74/488, 489, 551.1-551.9,
74/484 R; 200/157, 293.1, 310, 313, 314,
200/553, 4, 61.85, 61.87, 61.88, 293, 233,
200/302.1; 180/219, 321, 333, 220, 225,
180/223, 233, 229, 311, 312, 315, 335; D13/126,
D13/158; 280/288.4

See application file for complete search history.

(56) **References Cited**

U.S. PATENT DOCUMENTS

4,191,866 A * 3/1980 Nakajima et al. 200/4
4,455,463 A * 6/1984 Rohl 200/61.85
4,641,723 A * 2/1987 Takanashi et al. 180/315
4,838,113 A * 6/1989 Matsushima et al. 74/551.8
6,695,090 B2 * 2/2004 McAllister 180/333
D534,843 S * 1/2007 Higashi D12/174
D556,645 S * 12/2007 Madden D12/126

OTHER PUBLICATIONS

Drag Specialties 2003 FatBook, handlebar control kits with switches and clutch/brake control kits on pp. 560, and handlebar switches, switch housings, and control components on p. 561.*

J & P Cycles (R) 2003 Black Book, handlebar switches and switch housings on p. 209.*

* cited by examiner

Primary Examiner—Cathron C Brooks

Assistant Examiner—Linda Brooks

(74) *Attorney, Agent, or Firm*—Kermit D. Lopez; Luis M. Ortiz; Tuesday A. Kaasch

(57) **CLAIM**

The ornamental design for a left hand handlebar controller for an all terrain vehicle, as shown and described.

DESCRIPTION

FIG. 1 is a perspective view of a left hand handlebar controller for an all terrain vehicle showing our design;

FIG. 2 is a front elevational view thereof;

FIG. 3 is a back elevational view thereof;

FIG. 4 is a top plan view thereof;

FIG. 5 is a bottom plan view thereof;

FIG. 6 is a bottom perspective view thereof;

FIG. 7 is another bottom perspective view thereof;

FIG. 8 is a right side elevational view thereof; and,

FIG. 9 is a left side elevational view thereof.

The portions shown in broken lines form no part of the claimed design.

1 Claim, 9 Drawing Sheets

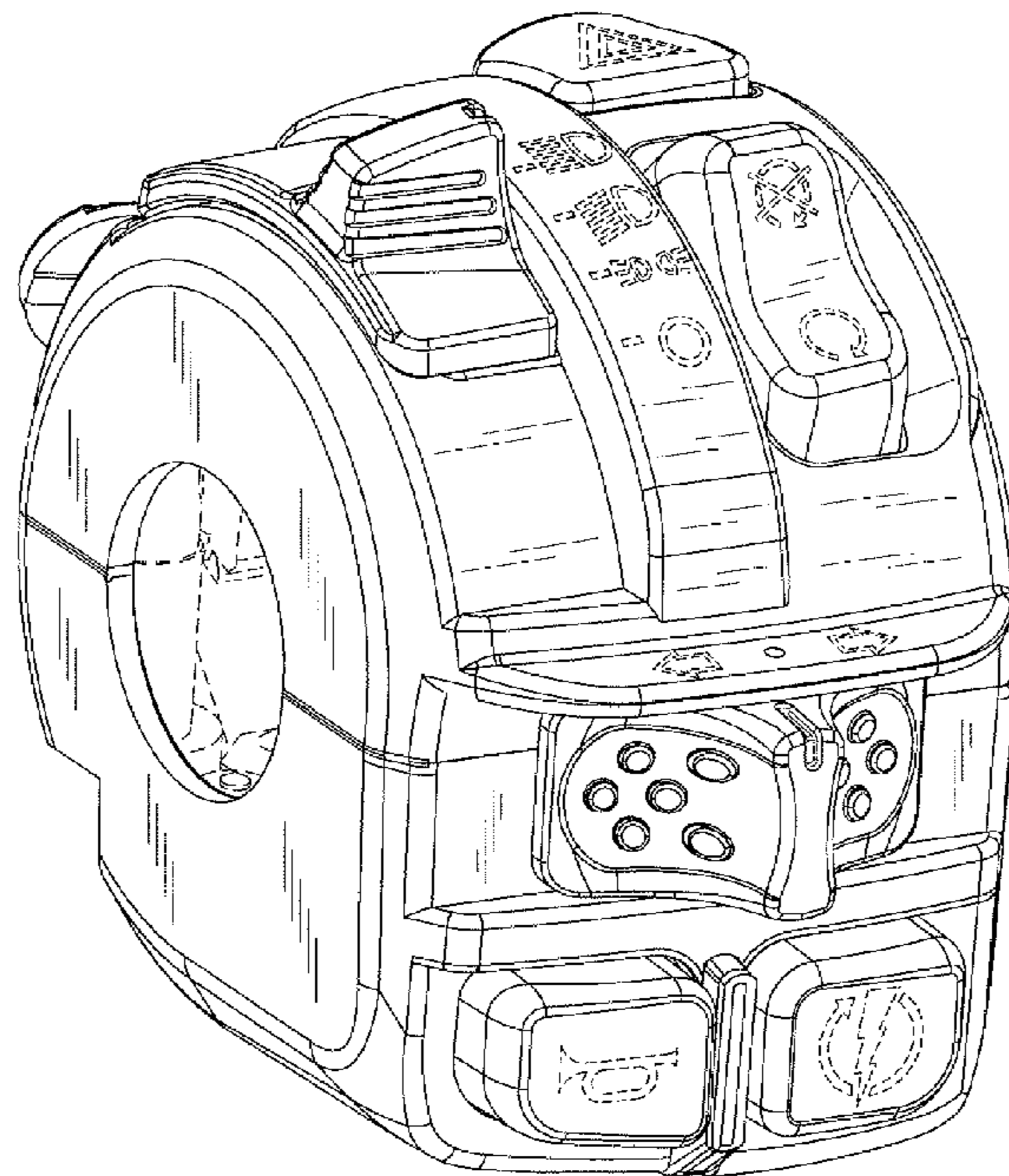

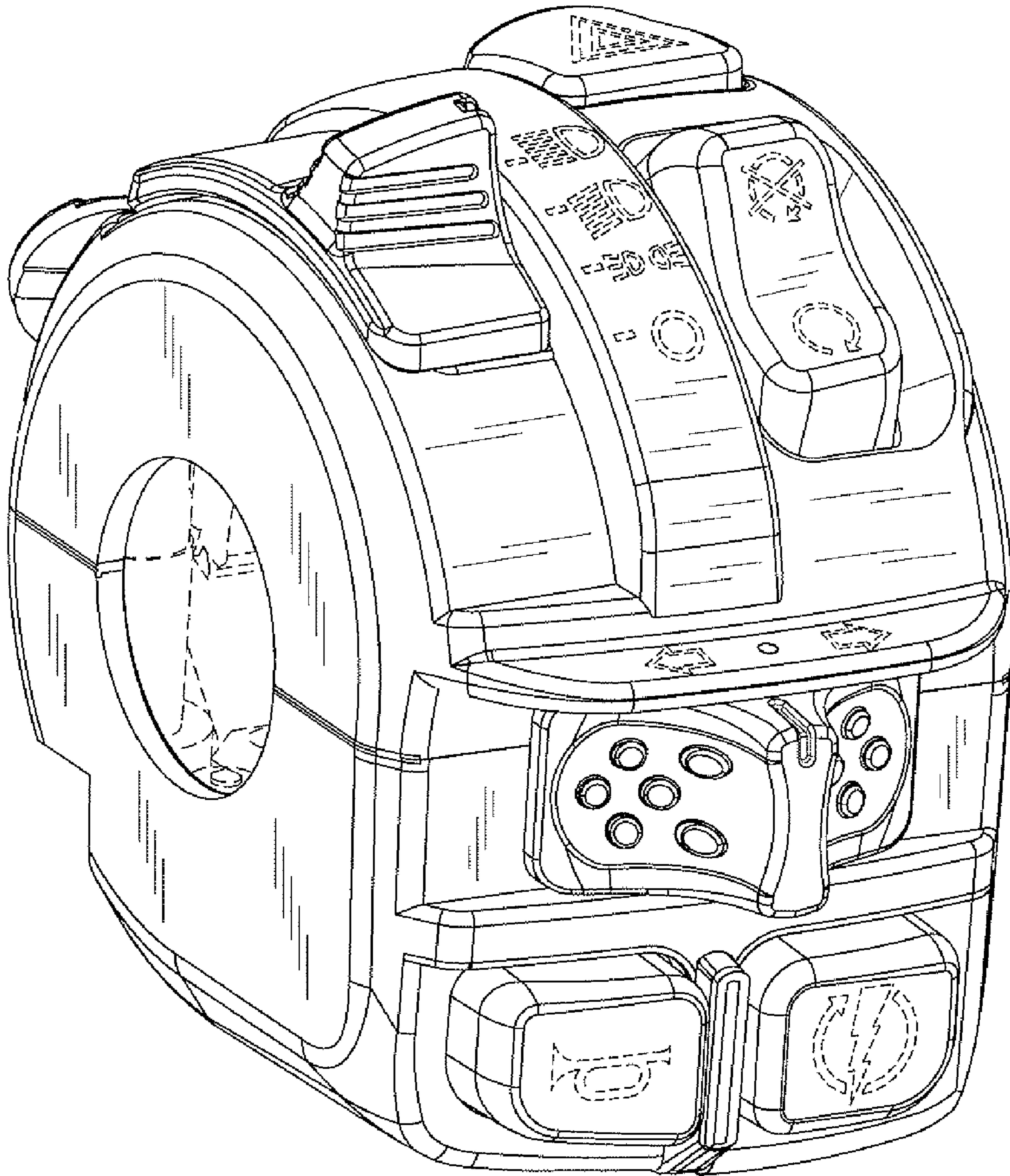

FIG. 1

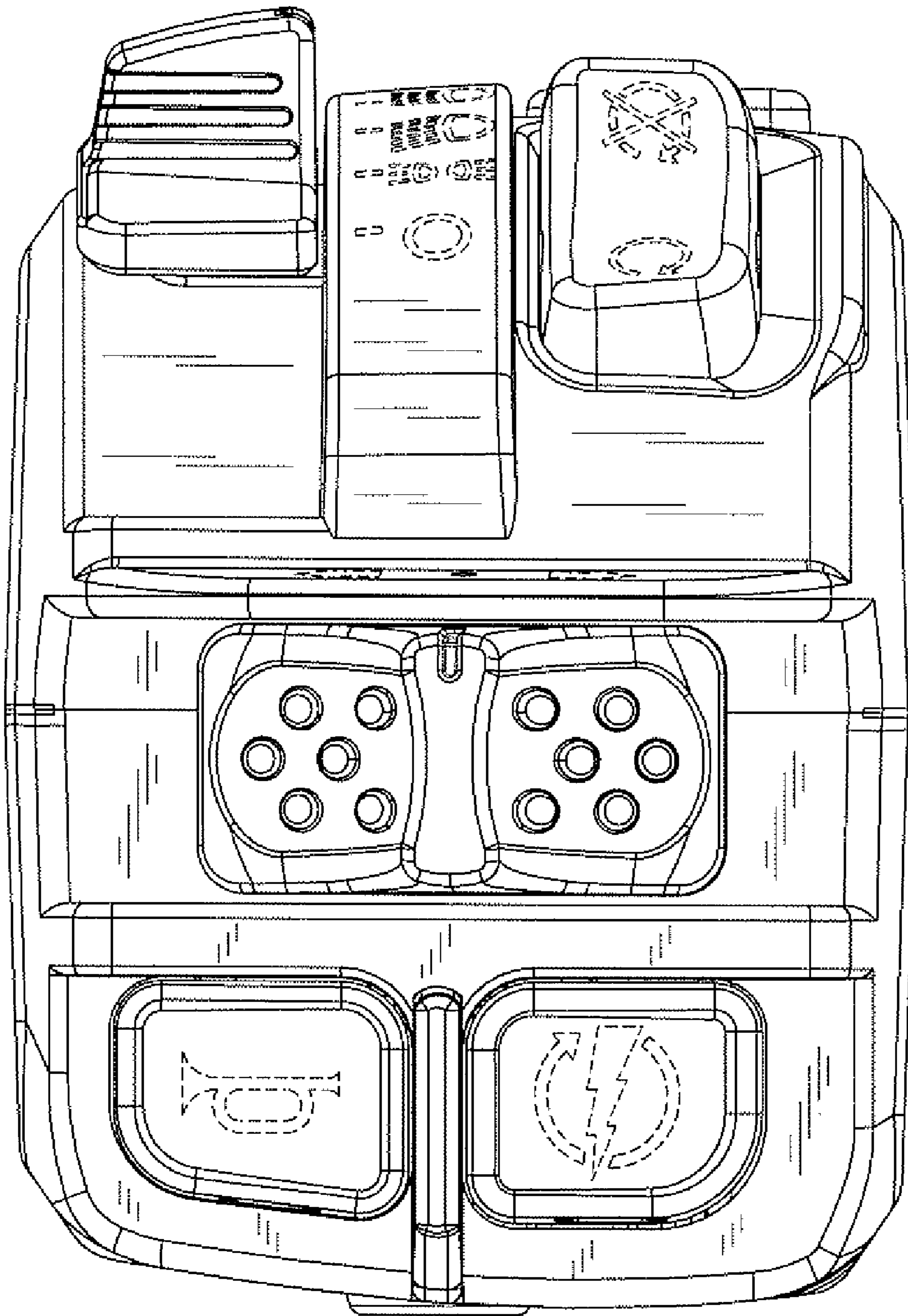

FIG. 2

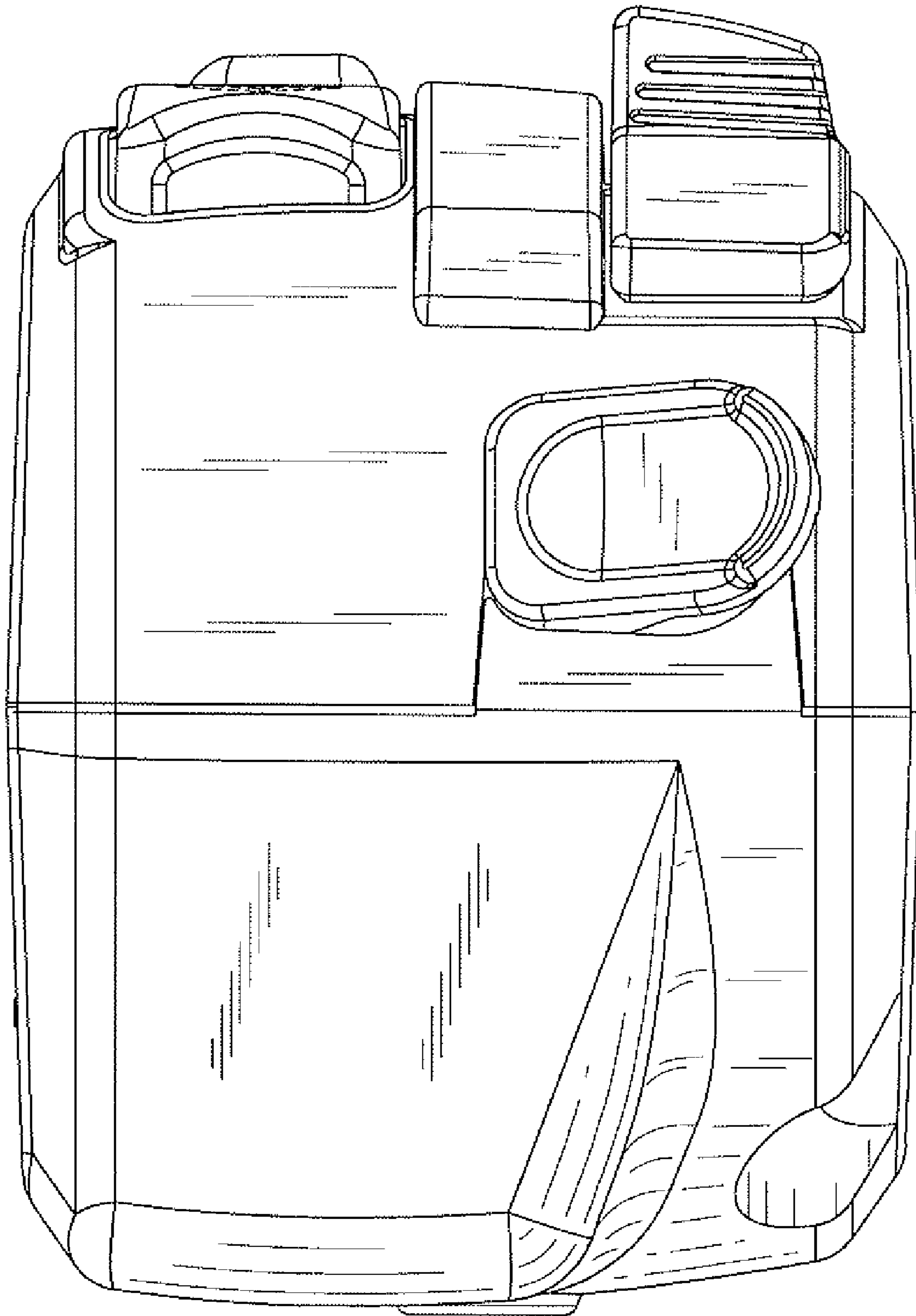

FIG. 3

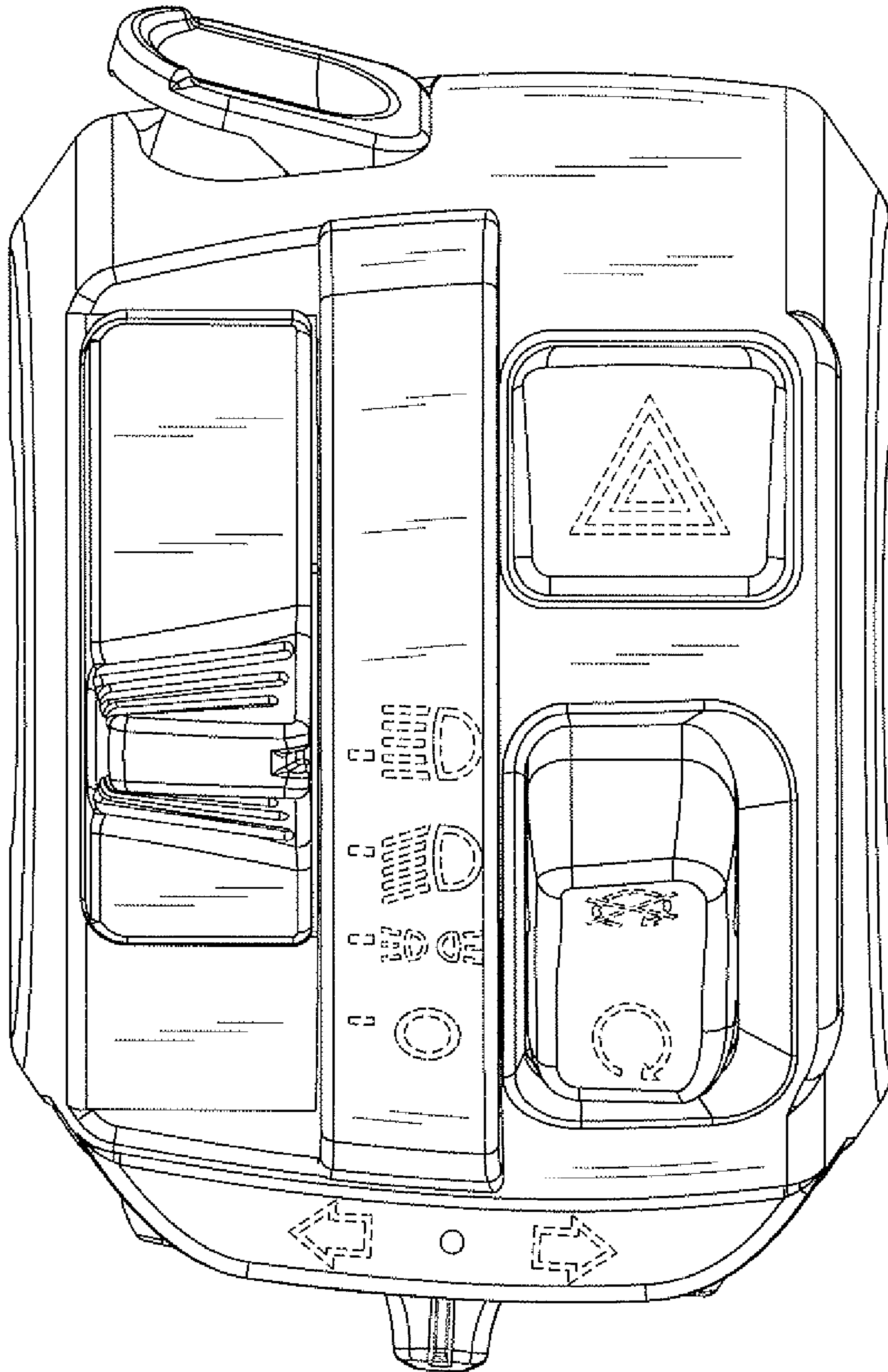

FIG. 4

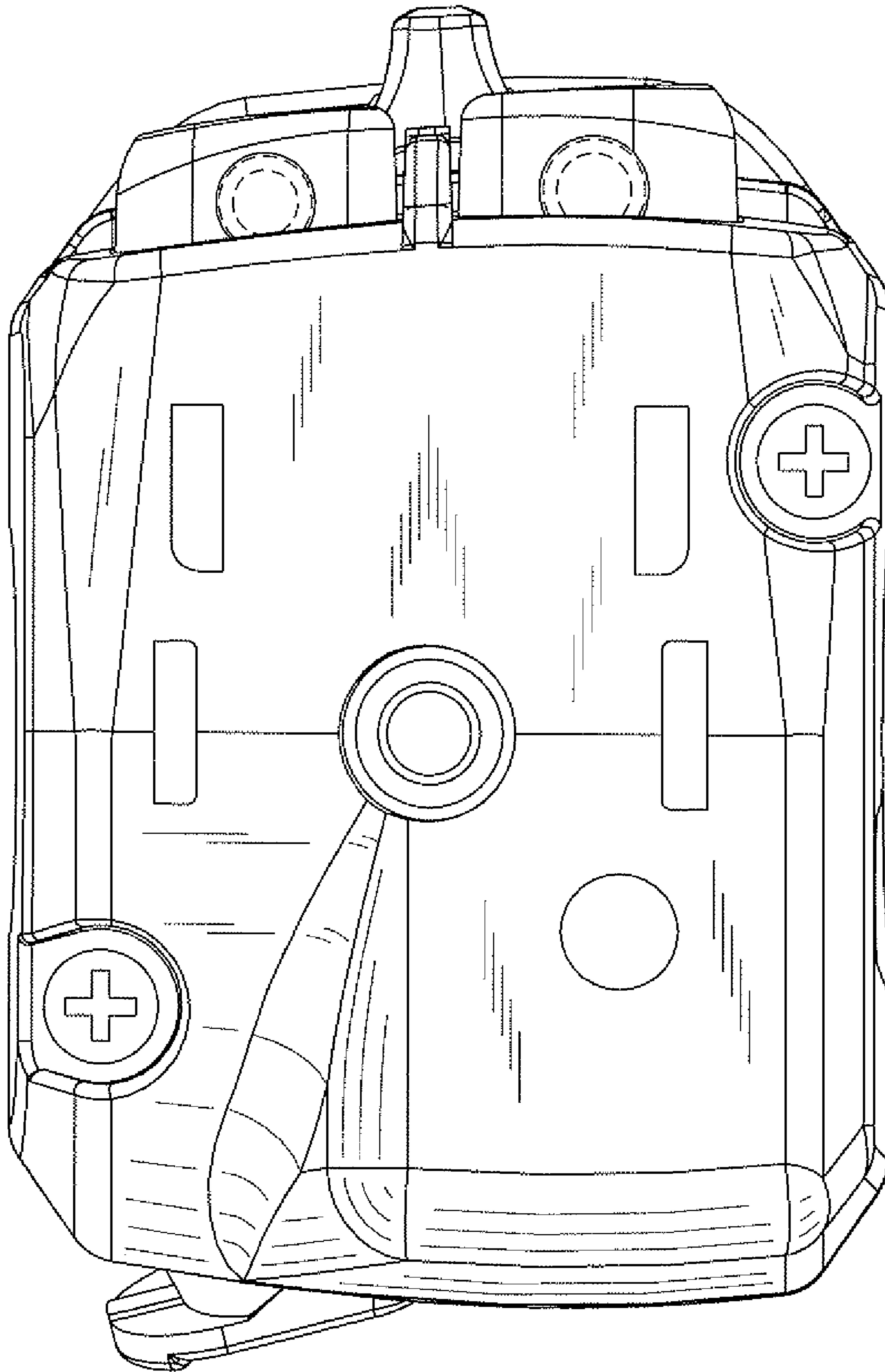

FIG. 5

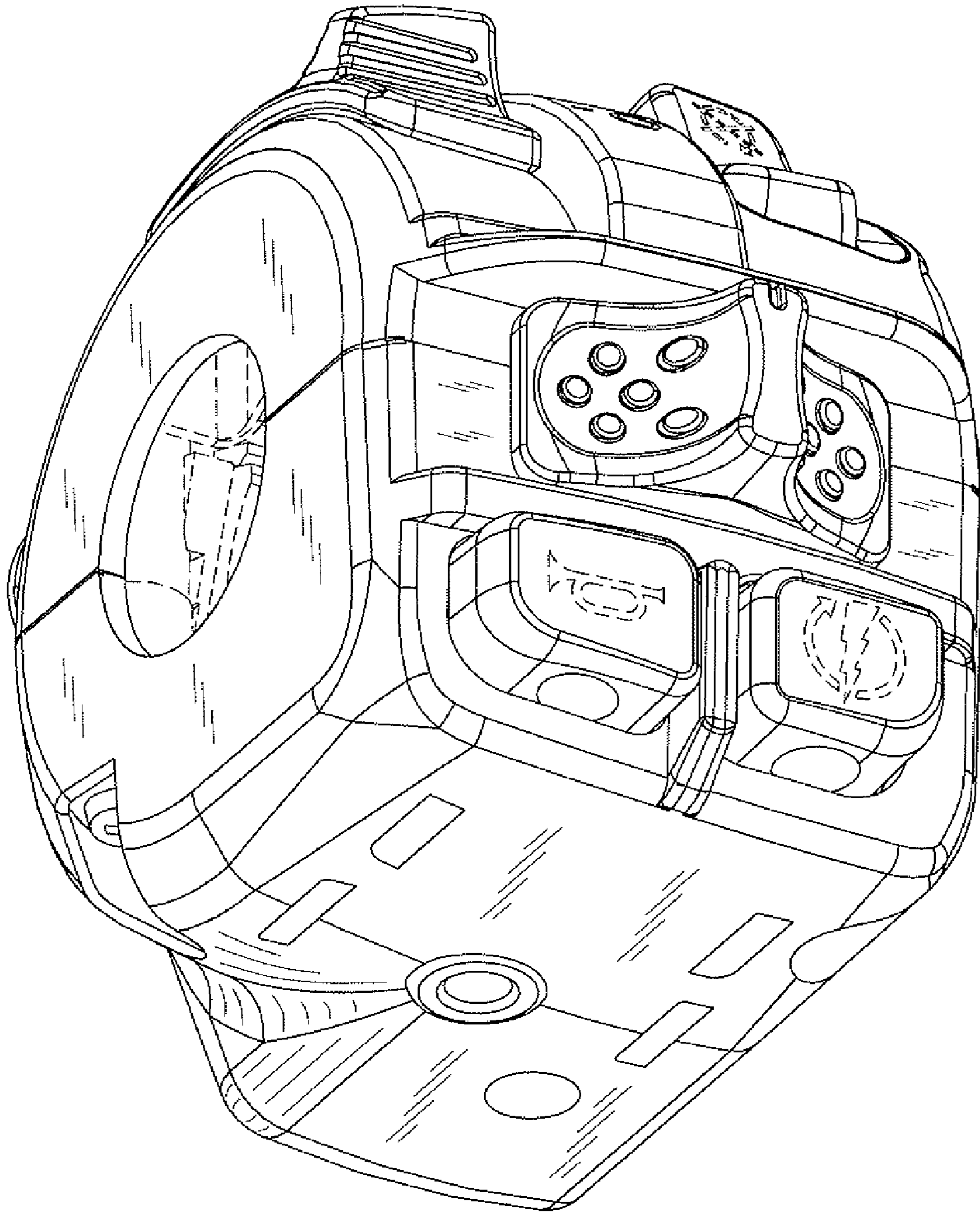

FIG. 6

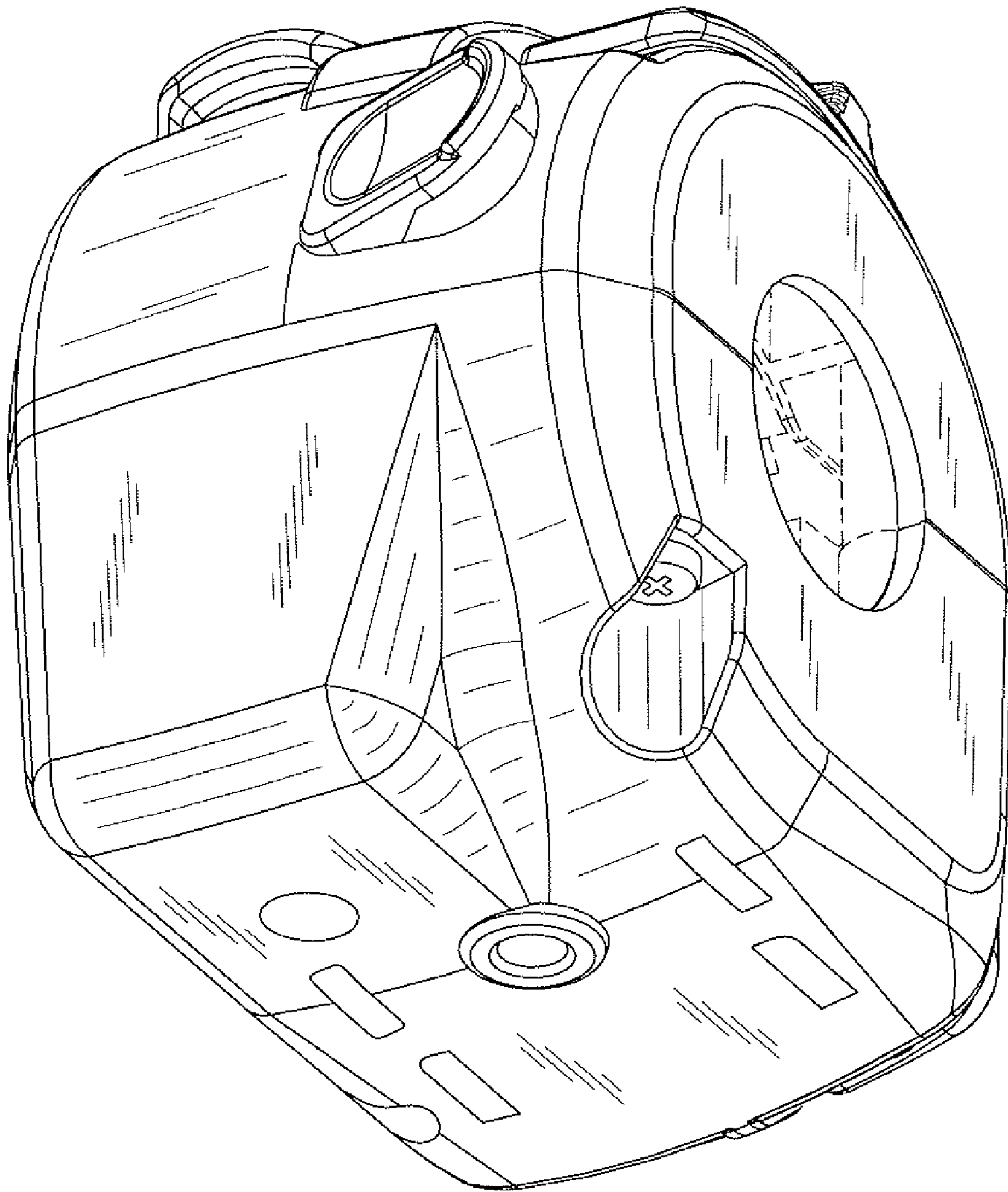

FIG. 7

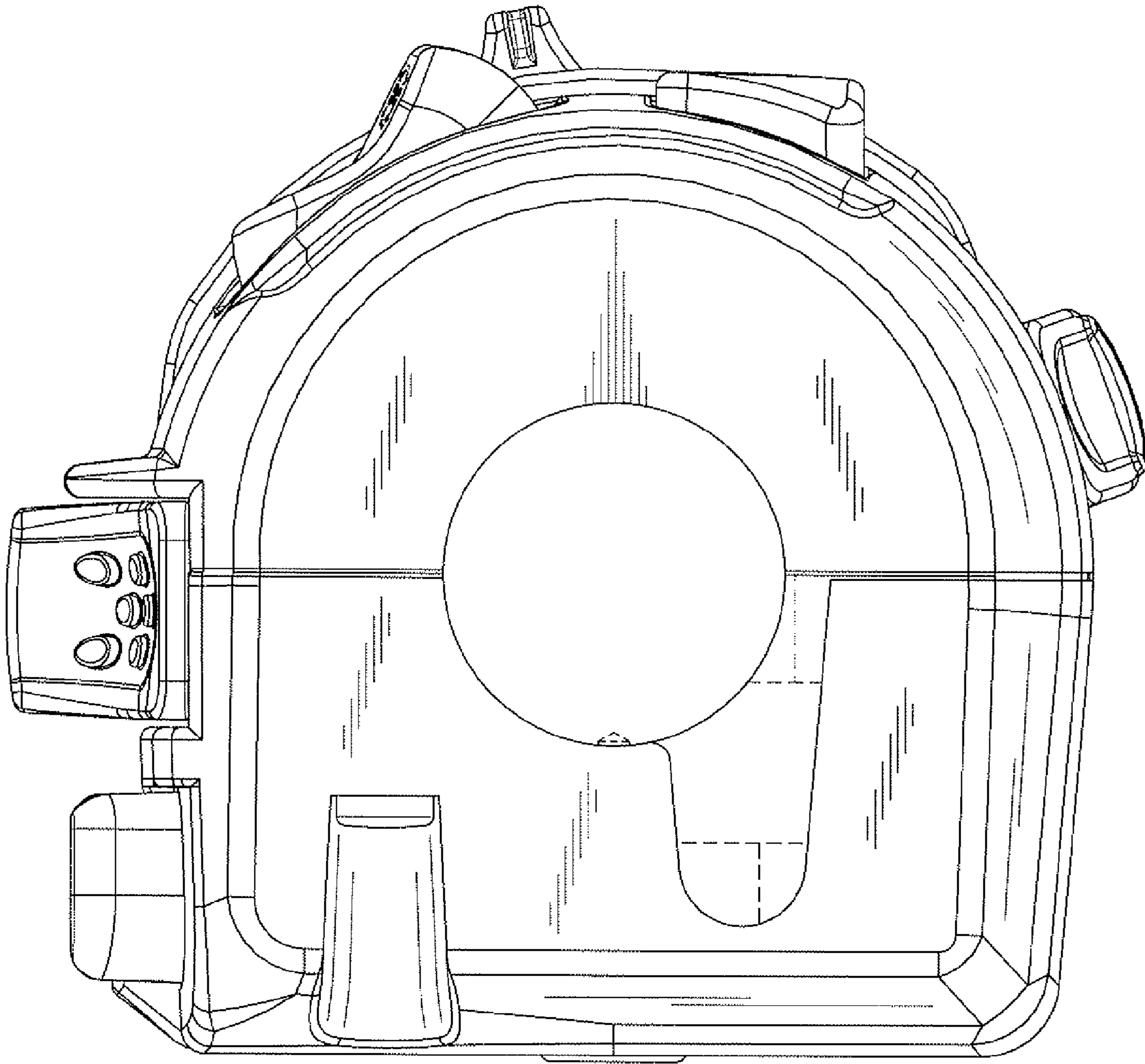

FIG. 8

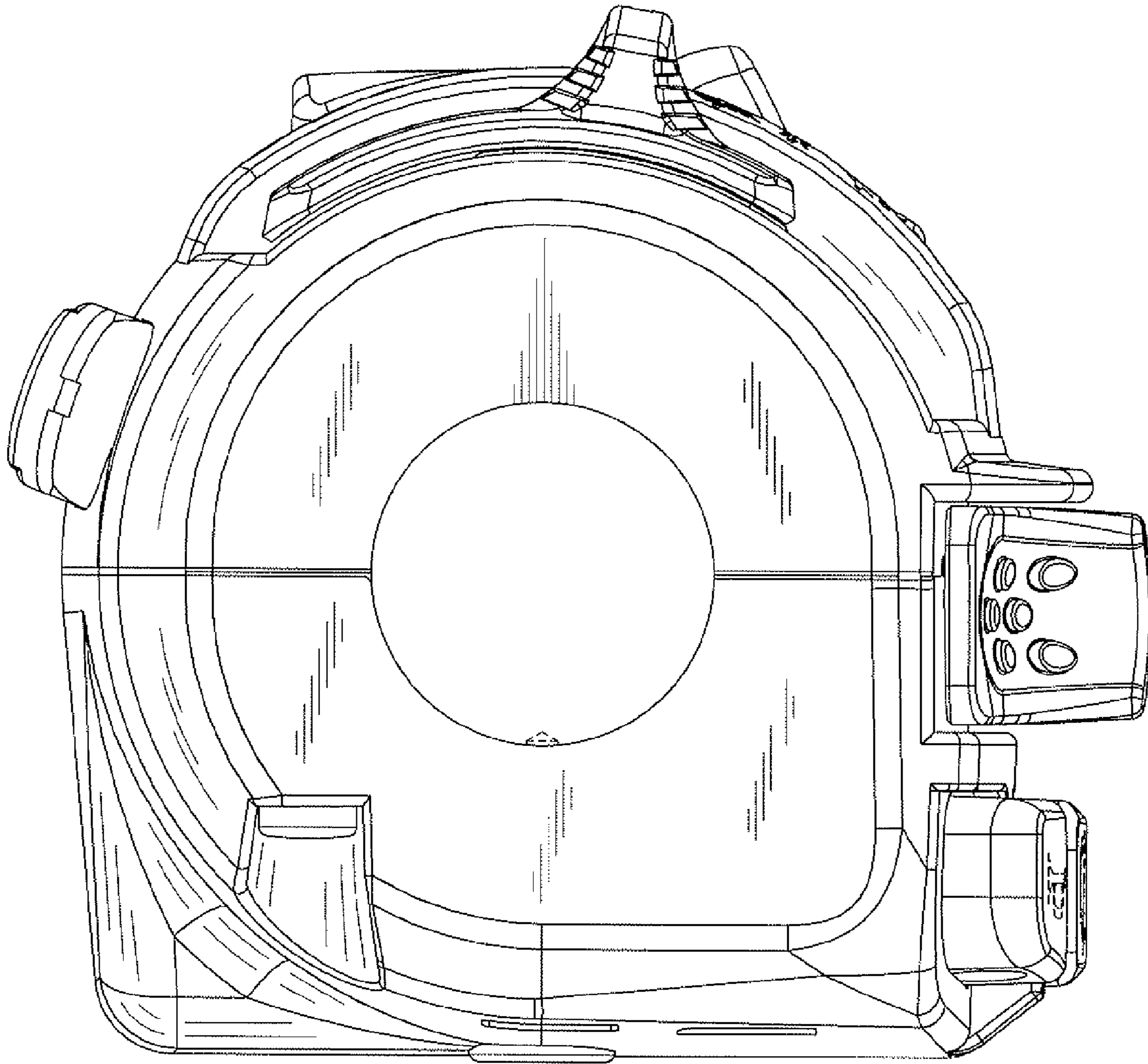

FIG. 9