



US00D599257S

(12) **United States Design Patent**
Gower et al.

(10) **Patent No.:** **US D599,257 S**
(45) **Date of Patent:** **** Sep. 1, 2009**

- (54) **FRONT PORTION OF A BUGGY**
- (75) Inventors: **Campbell Gower**, Wellington (NZ);
Philip Brace, Wellington (NZ)
- (73) Assignee: **Phil and Teds Most Excellent Buggy Company Limited**, Newton, Wellington (NZ)
- (**) Term: **14 Years**
- (21) Appl. No.: **29/324,429**
- (22) Filed: **Sep. 11, 2008**
- (51) **LOC (9) Cl.** **12-12**
- (52) **U.S. Cl.** **D12/133; D12/129**
- (58) **Field of Classification Search** **D12/128-133;**
296/65.03, 65.04; 224/409; 297/DIG. 4;
280/62, 647-650, 29, 200, 47.38, 250.1,
280/259, 642, 658

See application file for complete search history.

(56) **References Cited**

U.S. PATENT DOCUMENTS

D364,131 S	*	11/1995	Eichhorn et al.	D12/129
D505,366 S	*	5/2005	Refsum et al.	D12/129
D510,716 S	*	10/2005	Refsum et al.	D12/129
D515,986 S	*	2/2006	Donay	D12/129
D519,422 S	*	4/2006	Huang	D12/129
D520,415 S	*	5/2006	Liu	D12/129
D528,048 S	*	9/2006	Lin et al.	D12/129
D576,082 S	*	9/2008	de Reuver	D12/129

OTHER PUBLICATIONS

Phil & Teds Most Excellent Buggy Company, Kiwi Explorer Buggy Instructions, Phil & Teds Most Excellent Buggy Company Limited, Wellington, New Zealand, Oct. 2007, 7 pages.

Phil & Teds Most Excellent Buggy Company, New Product Release 2004, It's about Freedom—The E3, Phil & Teds Most Excellent Buggy Company Limited, Wellington, New Zealand, 2004, 2 pages.

Phil & Teds Most Excellent Buggy Company, The Twin—A Side By Side Buggy That's a Lot Less Trouble, Phil & Teds Most Excellent Buggy Company Limited, Wellington, New Zealand, 2004, 1 page.

Phil & Teds Most Excellent Buggy Company, Kiwi Explorer Buggy—5 Reasons, Phil & Teds Most Excellent Buggy Company Limited, Wellington, New Zealand, 2000, 2 pages.

Phil & Teds Most Excellent Buggy Company, The Buggy That Changes With Your Family's Needs—Single (Stage I: Newborn; Stage II: Toddler) Double (Stage III: Sibling; Stage IV: Double), Phil & Teds Most Excellent Buggy Company Limited, Wellington, New Zealand, 2004, 2 pages.

Phil & Teds Most Excellent Buggy Company, Inline Double Sport—Ones & Two's, Singles & Doubles, Phil & Teds Most Excellent Buggy Company Limited, Wellington, New Zealand, Mar. 2007, 2 pages.

Vibe Buggy—first disclosed after Apr. 16, 2007.

Dash Buggy—first disclosed after Sep. 13, 2007.

* cited by examiner

Primary Examiner—Charles A Rademaker

Assistant Examiner—Charles D Hanson

(74) *Attorney, Agent, or Firm*—Blakely, Sokoloff, Taylor & Zafman LLP

(57) **CLAIM**

The ornamental design for a front portion of a buggy, as shown and described.

DESCRIPTION

FIG. 1 is a perspective view of a front portion of a buggy showing our new design;

FIG. 2 is a front view thereof.

FIG. 3 is a side view thereof.

FIG. 4 is the other side view thereof.

FIG. 5 is a top view thereof.

FIG. 6 is a rear view thereof;

FIG. 7 is a rear view thereof; and,

FIG. 8 is a perspective view thereof.

Petitioners disclaim the shape and configuration of the features of the buggy shown in phantom lines.

The broken line portions shown in the drawings are included for the purpose of illustrating environment and form no part of the claimed design.

1 Claim, 8 Drawing Sheets

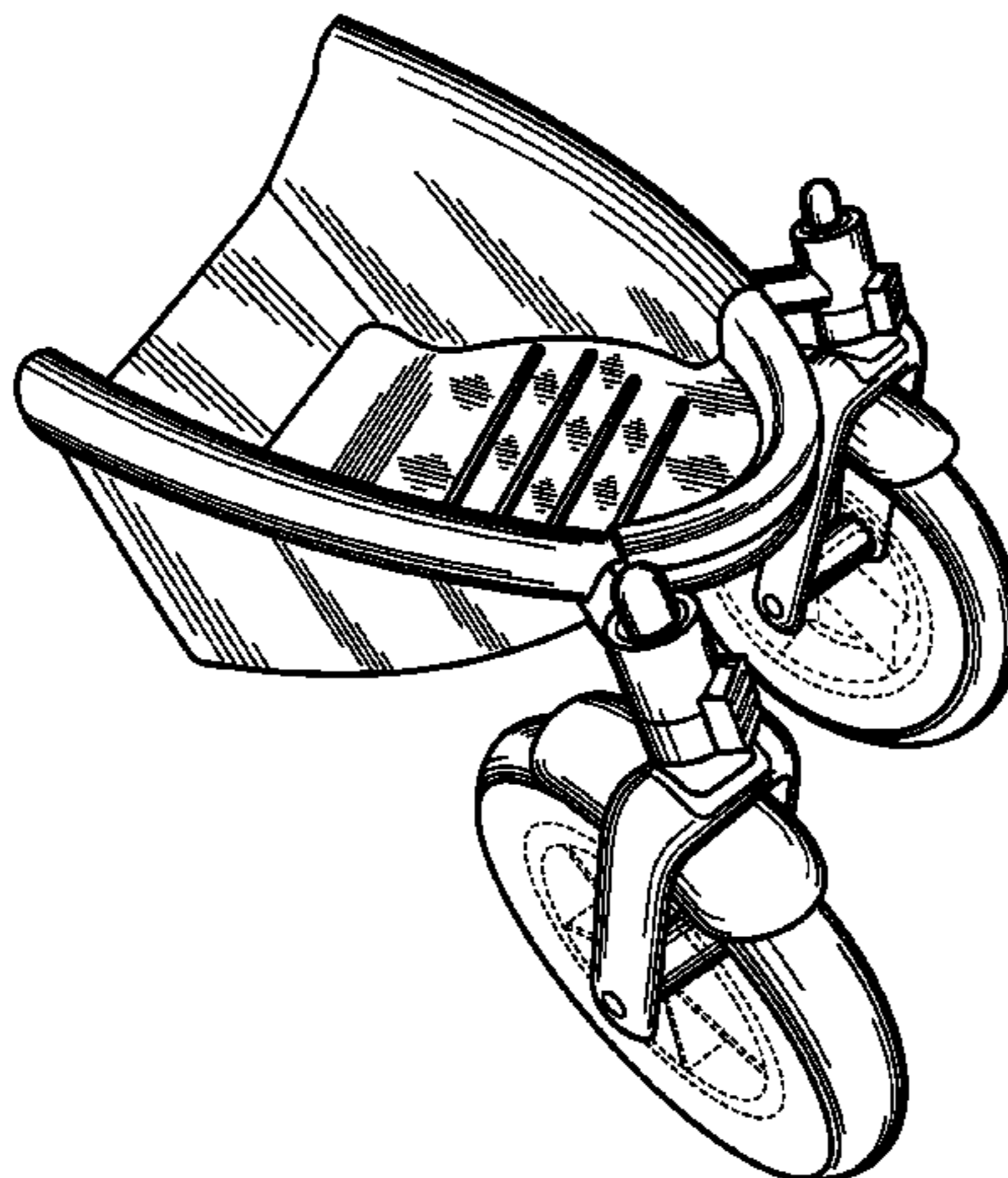

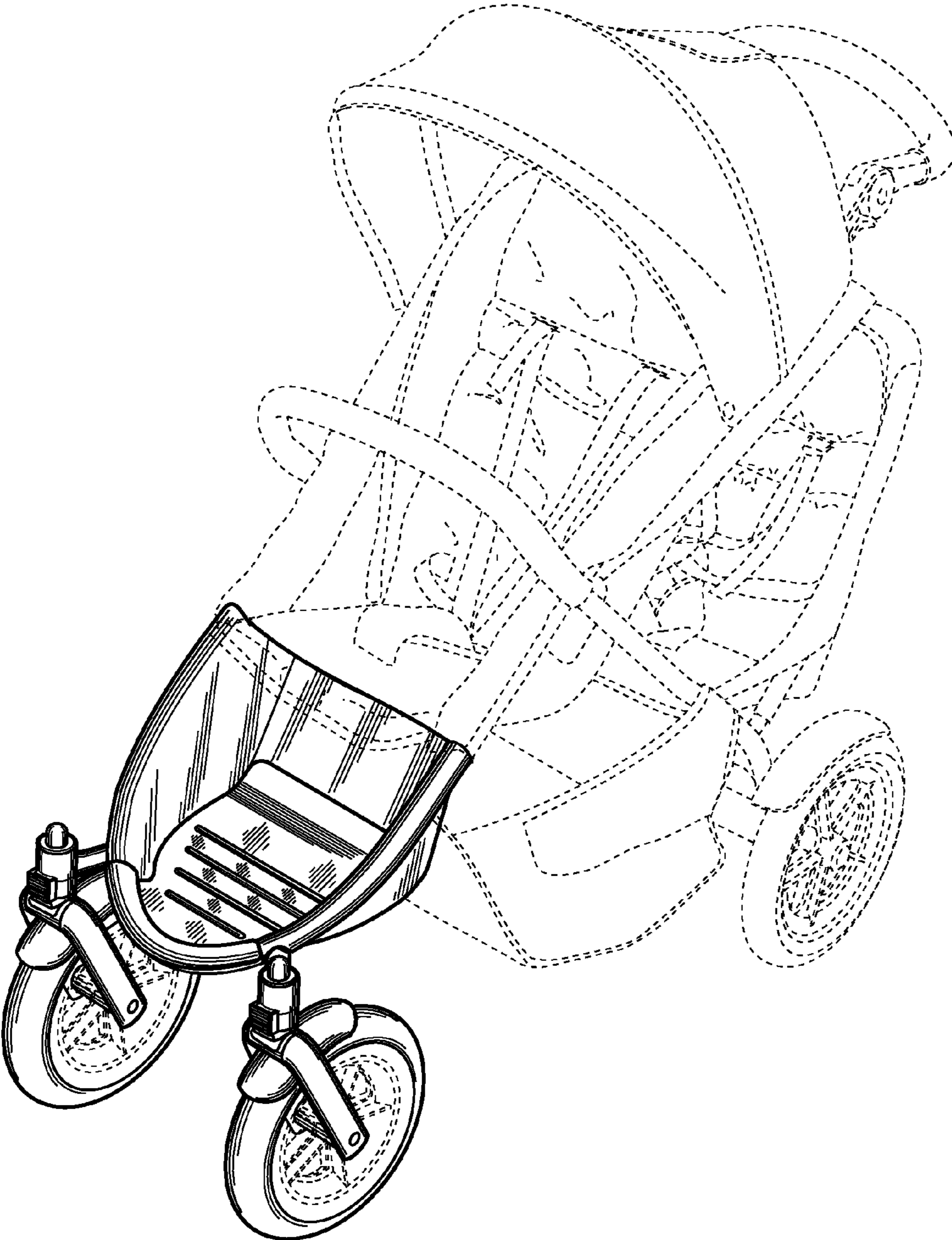

FIG.1

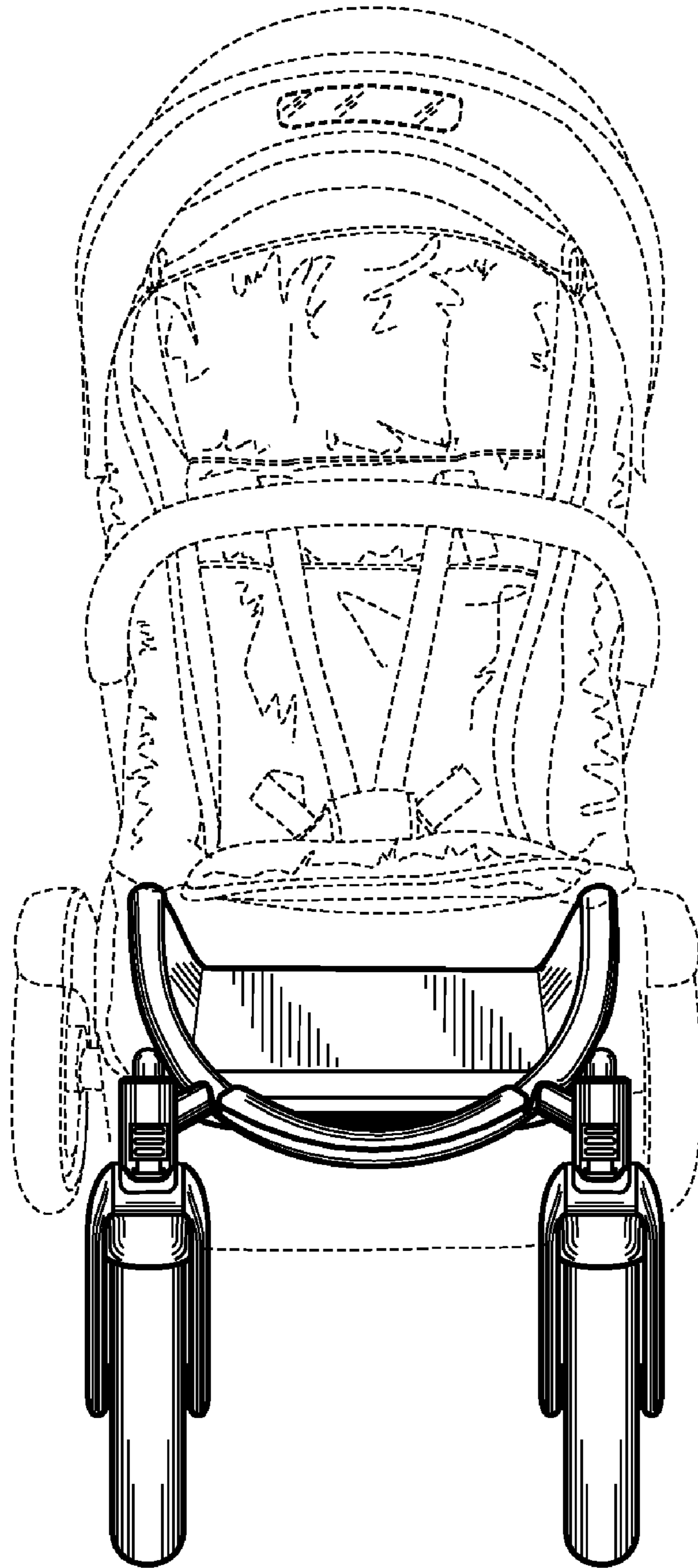

FIG. 2

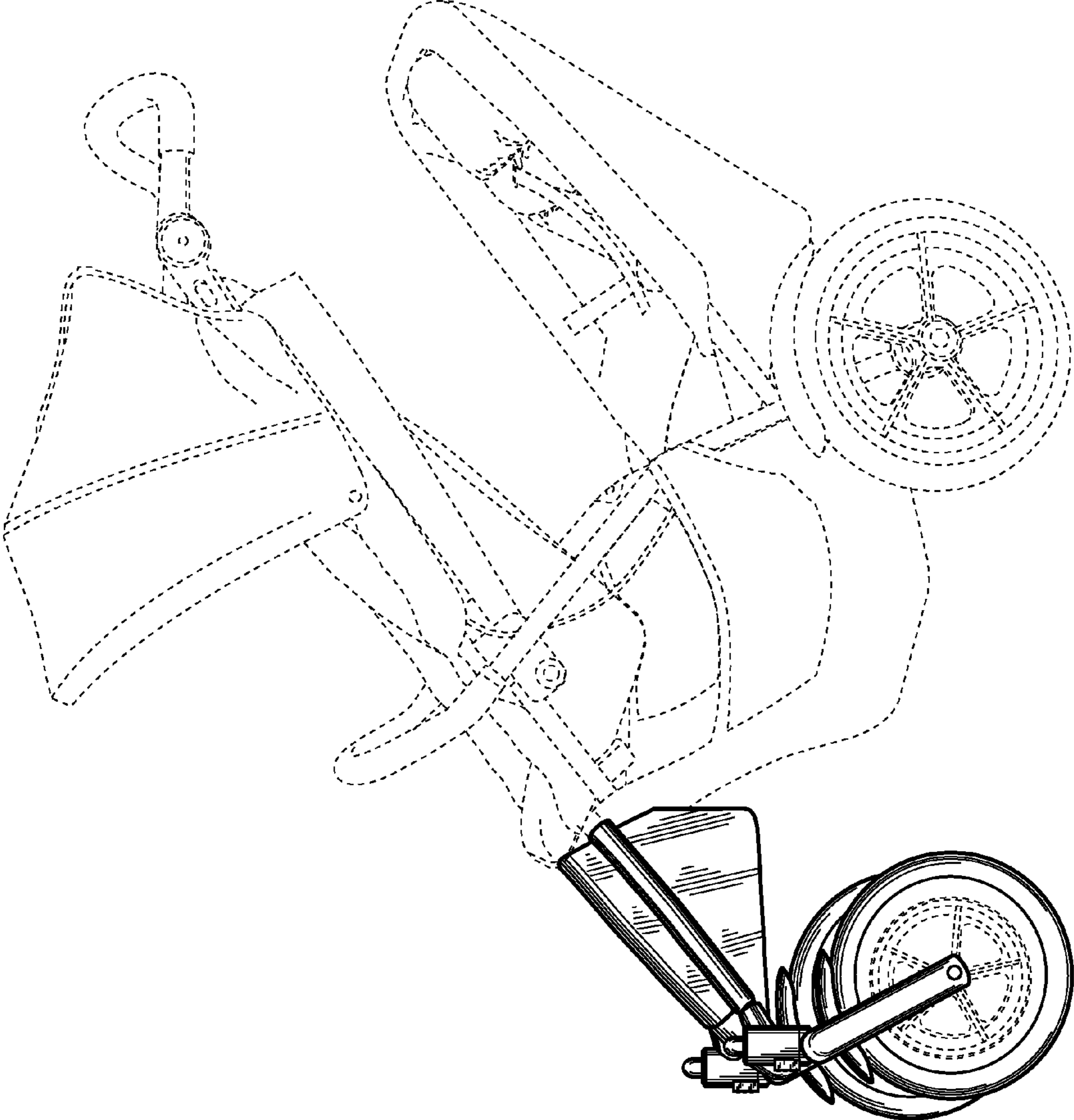

FIG.3

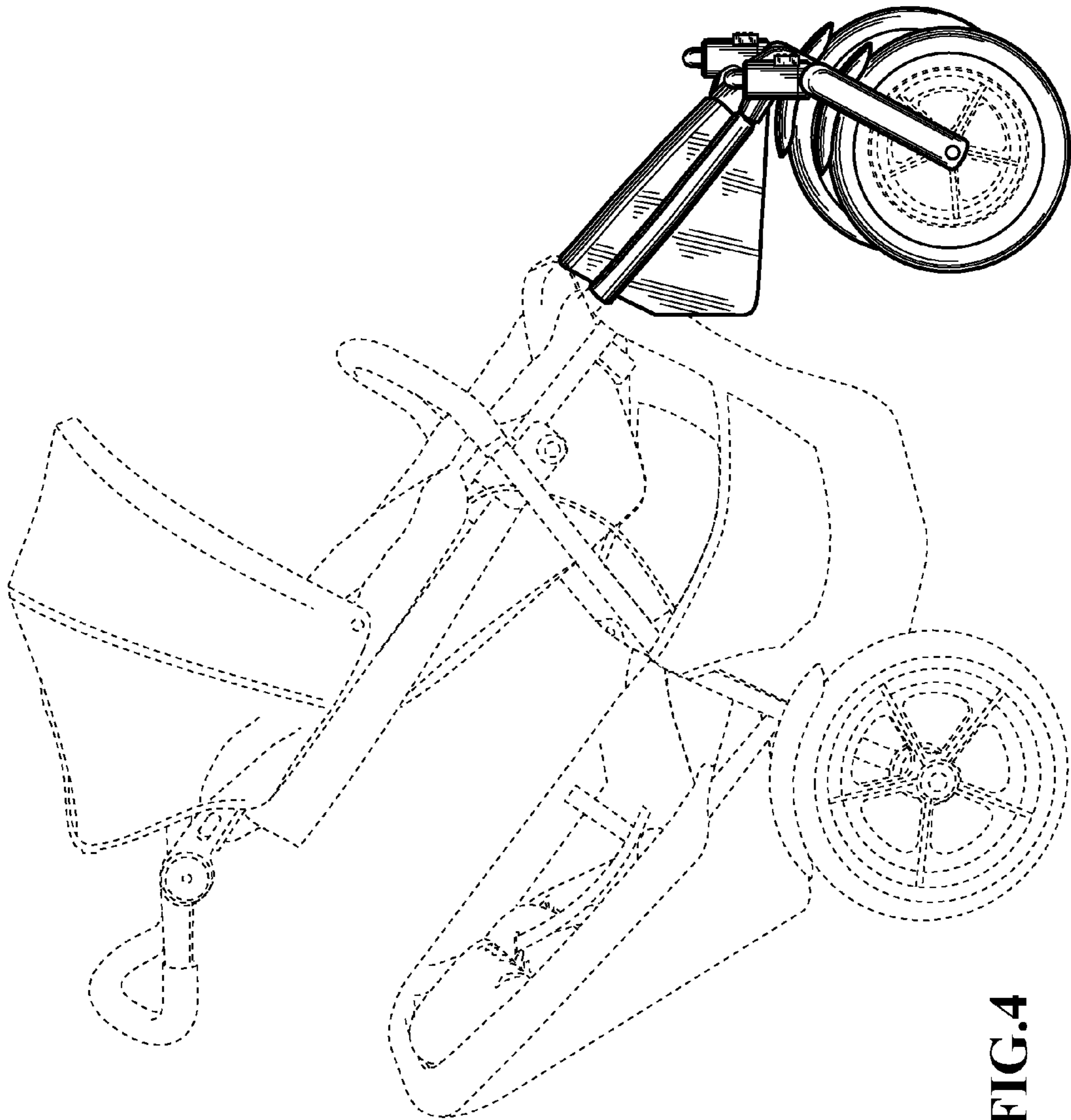

FIG.4

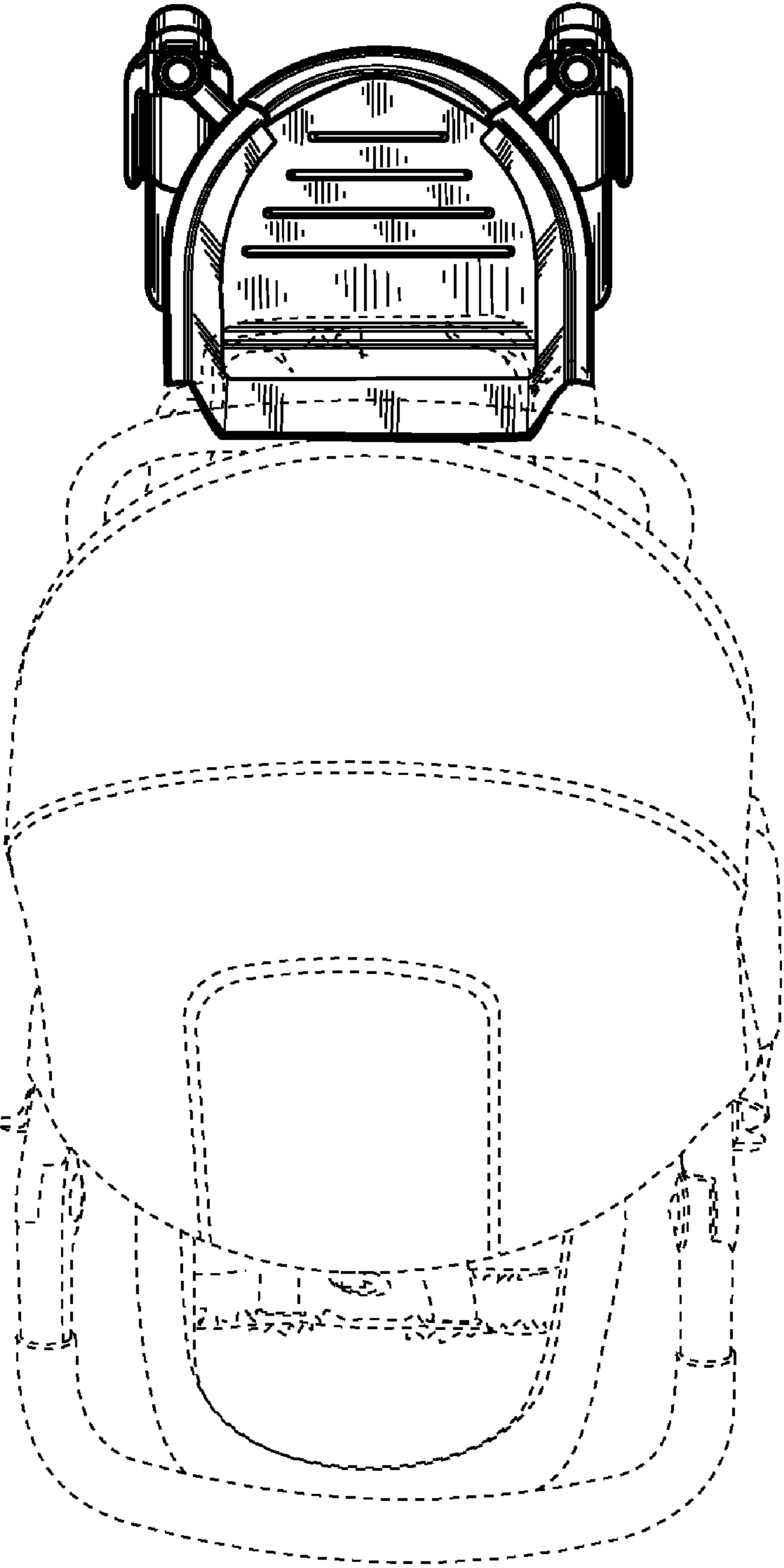

FIG. 5

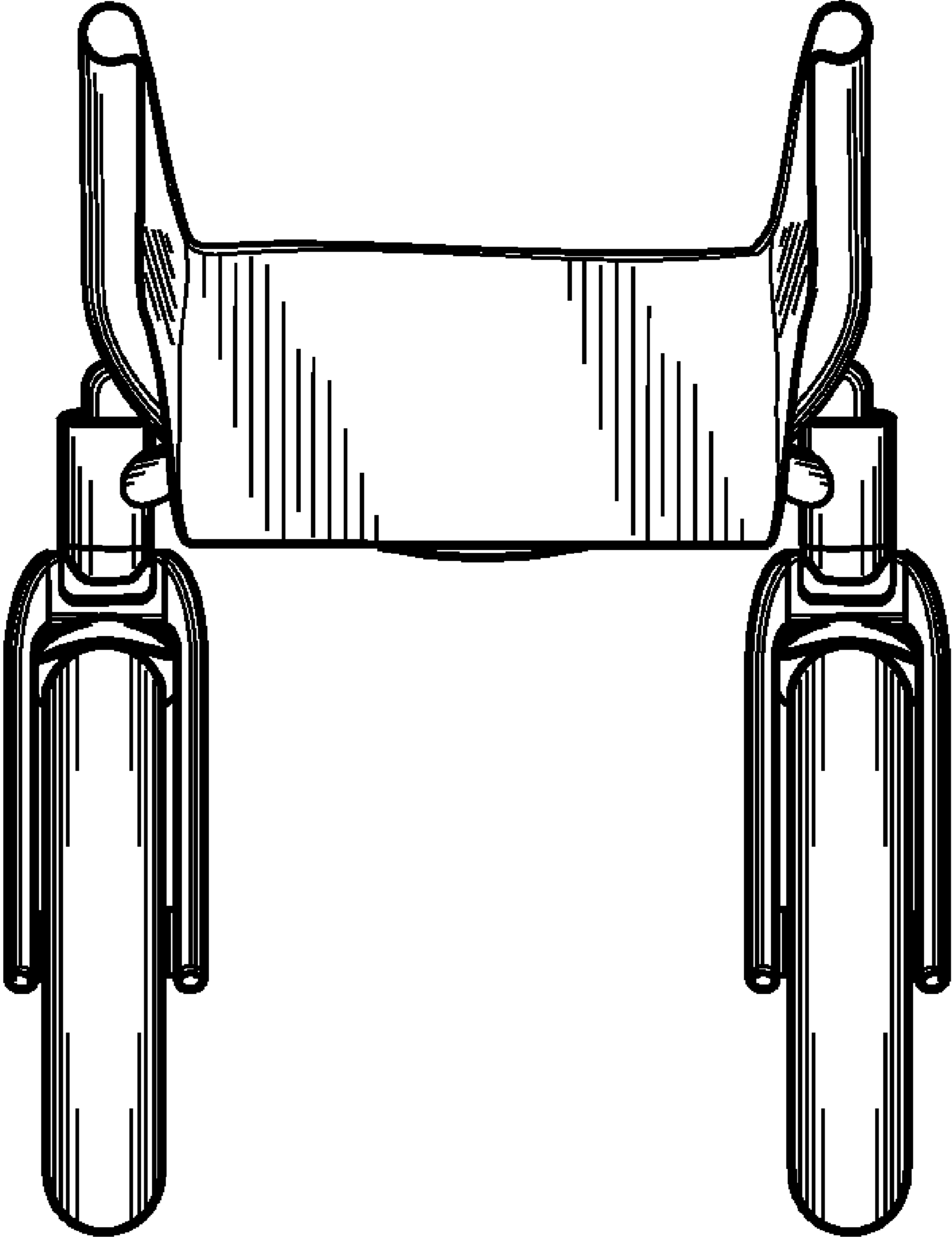

FIG.6

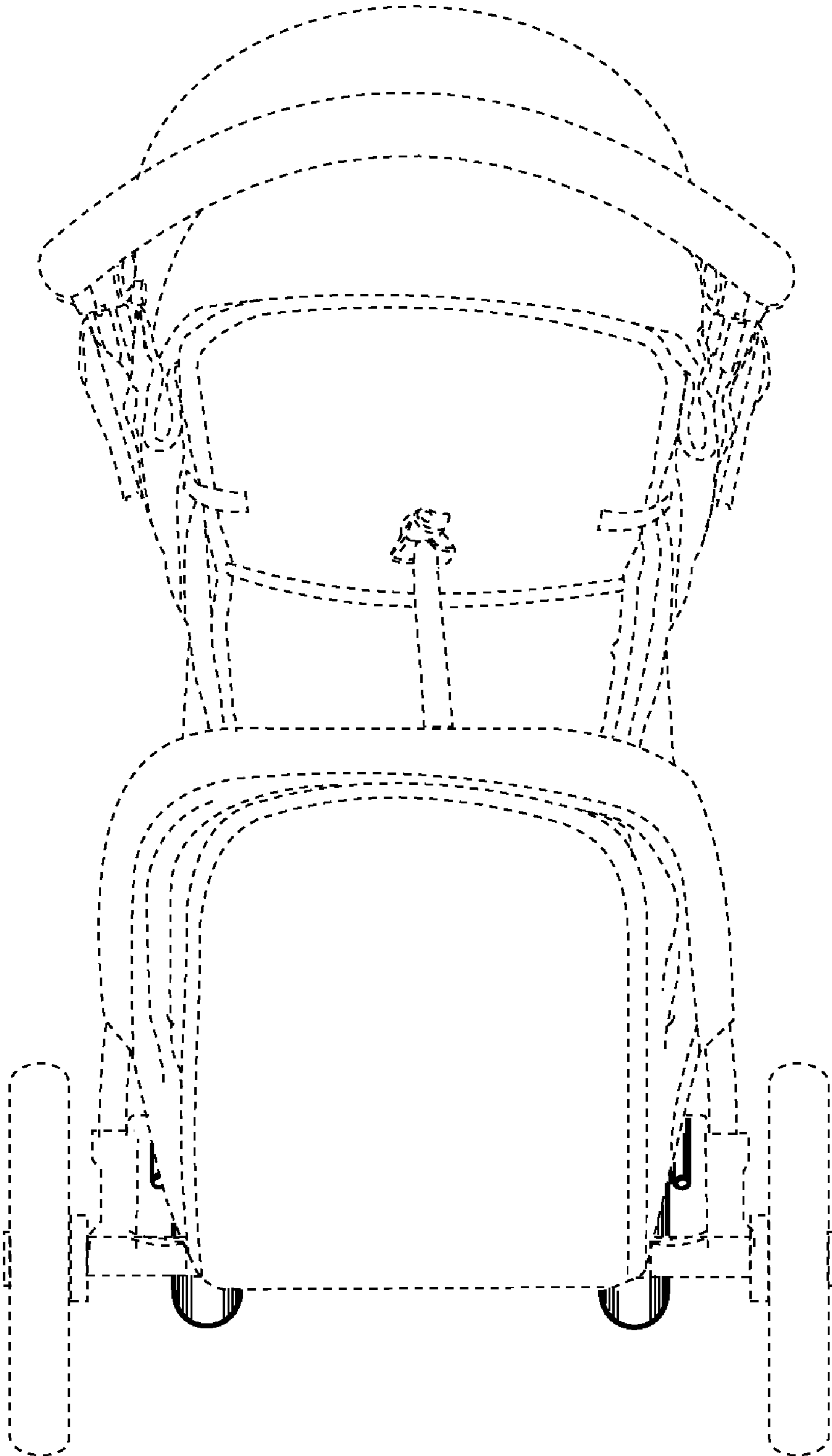

FIG.7

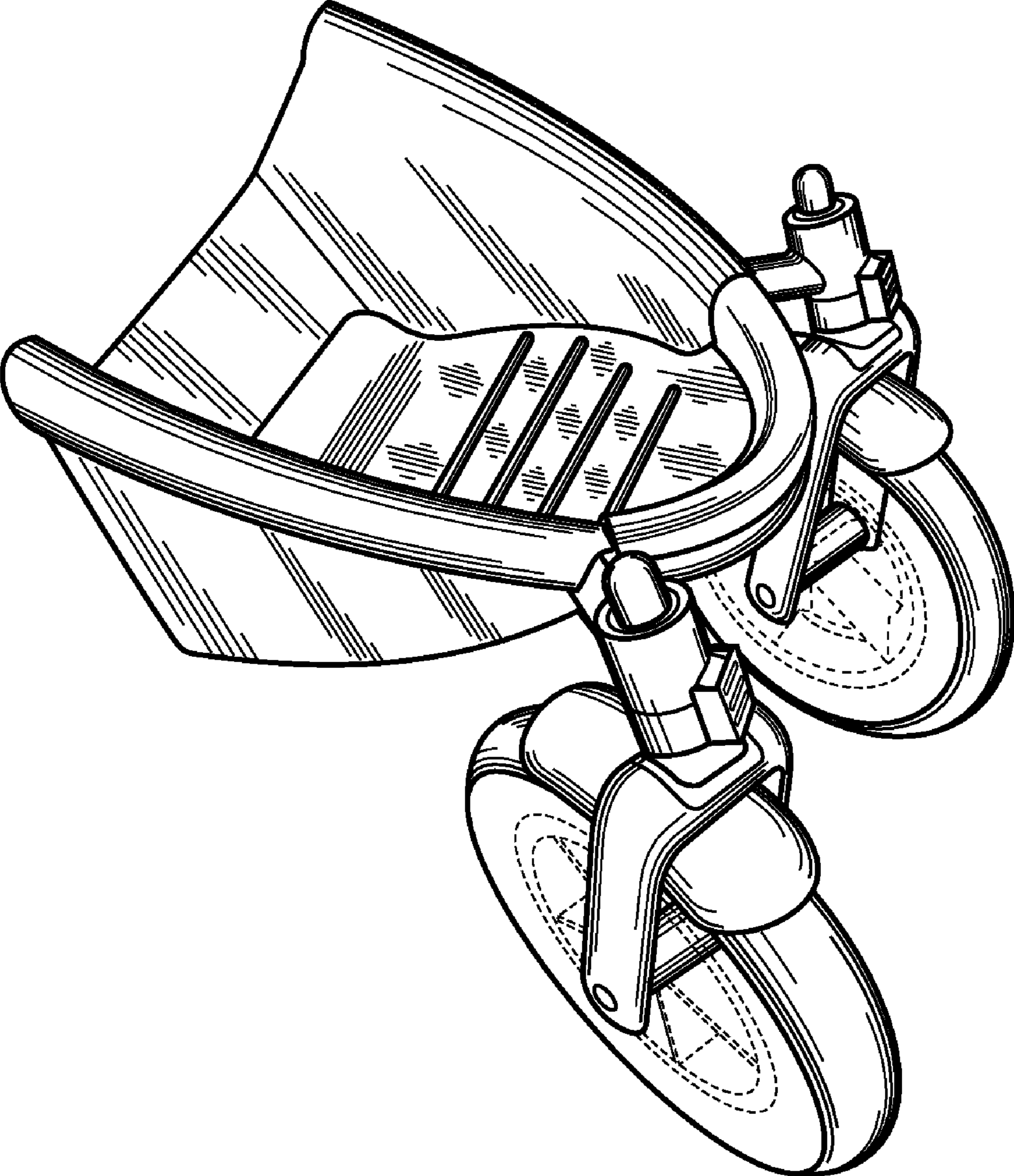

FIG.8